



Instruction Manual Chain Hoist Capacity:3t



ITEM# 20902102

NOTE: Before start using this hoist, read carefully
the instructions of this operation manual



Distributed by:
Forcome Co., Ltd
MADE IN CHINA

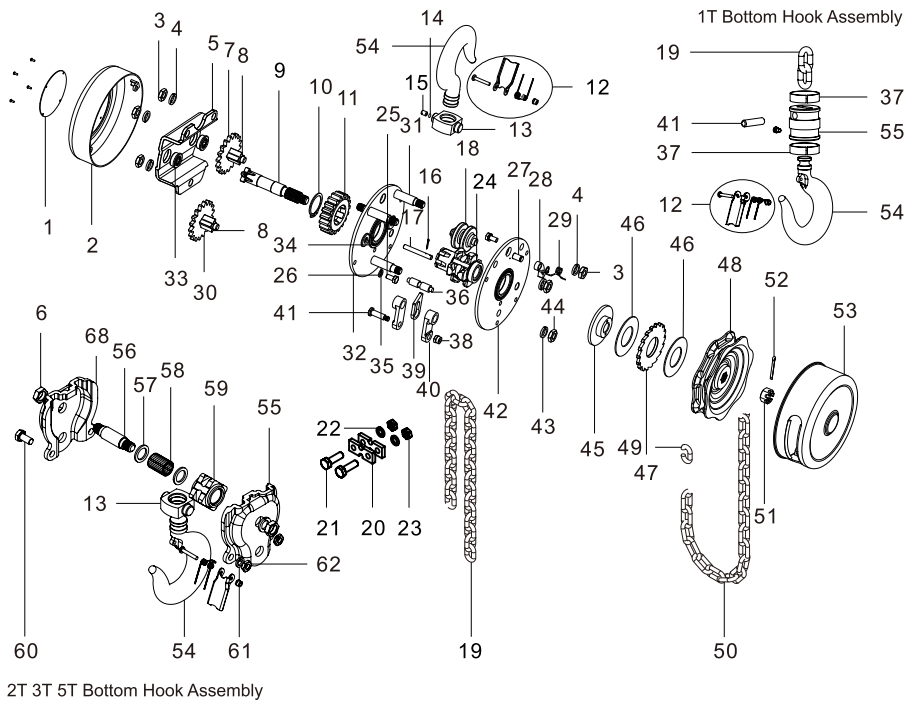

CONTENTS

1.Preface	1
2.Warning	2
3.Safety Instruction	4
4.Inspection and Maintenance	6
5.The Method for Maintenance and Inspection	9
6.Criteria for Using	10
7.Troubleshooting	11
8.Specifications	12
9.LIMITED WARRANTY	13
10.Exploded View & Part List	15

SPARE PART LIST

1	Name Plate	17	Pin	33	Bearing Race	49	Connecting Link
2	Sheet Cover	18	Chain Guide	34	Bearing Race	50	Hand Chain
3	Nut	19	Load Chain	35	Stay Bolt A	51	Stotted Nut
4	Washer	20	Chain Stop	36	Stripper Pin	52	Cotter Pin
5	Gear Cover	21	Bolt	37	Anchor Ring	53	Wheel Cover
6	Nut	22	Washer	38	Slotted Nut	54	Hook
7	Disc Gear A	23	Nut	39	Stripper	55	Bottom Hook Block
8	Pinion Shaft	24	Load Sheave	40	Chain Anchor Plate	56	Sheave Shaft
9	Driving Shaft	25	Bolt	41	Chain Pin	57	Retaining Ring
10	Circle	26	Washer	42	Wheel Side Plate	58	Needle
11	Splined Gear	27	Pawl Pin	43	Washer	59	Idle Sheave
12	Safety Latch	28	Pawl	44	Nut	60	Bolt
13	Hook Holder	29	Pawl Spring	45	Brake Seat	61	Washer
14	Steel Ball	30	Disc Gear B	46	Friction Disc	62	Nut
15	Screw	31	Stay Bolt B	47	Ratchet		
16	Cotter Pin	32	Gear Side Plate	48	Hand wheel		

THANK YOU VERY MUCH FOR SELECTING OUR MANUAL HOIST

This instruction manual describes correct operating method to ensure prolonged service life. Please read and completely understand this manual before operating the Manual Hoist. Always keep this manual at an appropriate place. If the manual or warning decal is missing, please contact your vendor.

NOTE: All information reported herein is based on the data available at the time of printing. The factory reserves the right to modify its own products at any time without notice or incurring in any sanction. Please verify with the factory for possible updates.

1.PREFACE

This manual hoist is a portable lifting device easily operated by hand chain. It's suitable for use in factories, mines, farms, construction sites, wharves, docks and warehouses for installation of equipment, as well as for loading and unloading goods. It's specially advantageous for lifting work in open air grounds and places where no power supply is available. The manual hoist can be attached to a trolley of any type as traveling chain block. It is suitable to monorail overhead conveying system, hand traveling crane and jib crane.

remedy under this limited warranty or any other warranty related to the product. We shall not be liable for: service or labor charges or damage to Your property incurred in removing or replacing the product; any damages, including, without limitation, damages to tangible personal property or personal injury, related to Your improper use, installation, or maintenance of the product or product component; or any indirect, incidental or consequential damages of any kind for any reason.

Assumption of Risk

You acknowledge and agree that any use of the product for any purpose other than the specified use(s) stated in the product instructions is at Your own risk.

LIMITED WARRANTY

Forcome Co., Ltd. ("We" or "Us") warrants to the original purchaser only ("You" or "Your") that the X-Power product purchased will be free from material defects in both materials and workmanship, normal wear and tear excepted, for a period of 90 days from date of purchase. The foregoing warranty is valid only if the installation and use of the product is strictly in accordance with product instructions. There are no other warranties, express or implied, including the warranty of merchantability or fitness for a particular purpose. If the product does not comply with this limited warranty, Your sole and exclusive remedy is that We will, at our sole option and within a commercially reasonable time, either replace the product or product component without charge to You or refund the purchase price (less shipping). This limited warranty is not transferable.

Limitations on the Warranty

This limited warranty does not cover: (a) normal wear and tear; (b) damage through abuse, neglect, misuse, or as a result of any accident or in any other manner; (c) damage from misapplication, overloading, or improper installation; (d) improper maintenance and repair; and (e) product alteration in any manner by anyone other than Us, with the sole exception of alterations made pursuant to product instructions and in a workmanlike manner.

Obligations of Purchaser

You must retain Your product purchase receipt to verify date of purchase and that You are the original purchaser. To make a warranty claim, contact Us at 1-888-380-7428, identify the product by make and model number, and follow the claim instructions that will be provided. The product and the purchase receipt must be provided to Us in order to process Your warranty claim. Any returned product that is replaced or refunded by Us becomes our property. You will be responsible for return shipping costs or costs related to Your return visit to a retail store.

Remedy Limits

Product replacement or a refund of the purchase price is Your sole

WARNING



1. Never lift more than rated load.



2. Never use the hoist with twisted, kinked.



3. Never use load chain as a sling or wrap chain around the load.

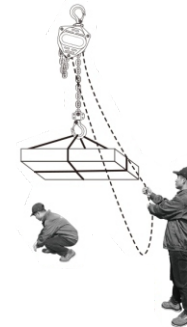

4. Never lift or transport loads over or near people.



5. Never lift a load unless chain is properly seated in chain wheel(s).

⚠ WARNING

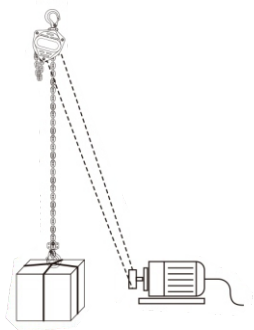

6. Never operate a hoist with other than manual power.

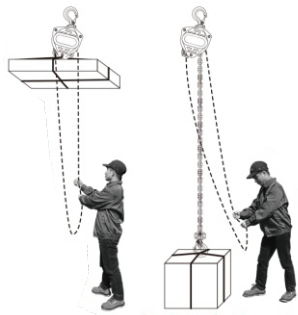

7. Never pull up too high or too low.



8. Never pull at an angle, be sure hoist and load are in a straight line.



9. Never permit more than one operator to pull on a single hand chain at one time.

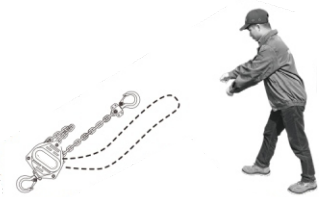

10. Never throw the chain block.



11. Never use hoist to lift, support or transport people.

SPECIFICATIONS

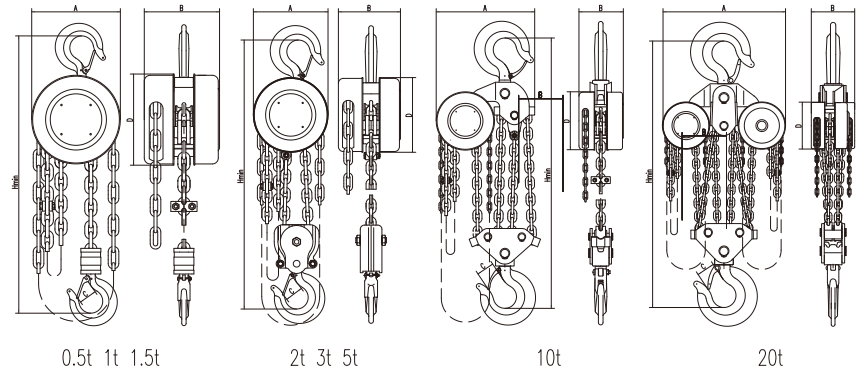

Capacity	t	0.5	1	1.5	2	3	5	10	20
Standard Lift	m	2.5	2.5	2.5	2.5	3	3	3	3
Test Load	t	0.75	1.5	2.25	3	4.5	6.25	12.5	25
Headroom	mm	240	270	350	380	470	600	700	1000
Effort to lifting max. load	N	221	304	343	314	343	381	392	392
Load Chain Falls		1	1	1	2	2	2	4	8
Dia. of Load Chain		6	6	8	6	8	10	10	10
Dimensions	A	120	142	178	142	178	210	358	580
	B	108	122	139	122	139	162	162	189
	C	24	28	34	34	38	48	64	82
	D	120	142	178	142	178	210	210	210
Net Weight	kg	8	10	16	14	24	36	68	156
Gross Weight	kg	10	13	20	17	28	45	83	194
Packing Dimensions	cm	28 × 21 × 17	30 × 24 × 18	34 × 29 × 20	33 × 25 × 19	38 × 30 × 20	45 × 35 × 24	55 × 52 × 28	72 × 46 × 85
Extra Weight per Meter of Extra Lift	kg	1.7	1.7	2.3	2.5	3.7	5.3	9.7	19.4

TROUBLESHOOTING

Trouble	Cause	Remedy
Hoist will not lift load	Hoist is overload.	Reduce load to within hoist rated capacity.
Slip caused by ineffective braking	Worn-out friction discs.	Replace with new friction discs.
	Excessive oil on the braking surface.	Disassemble and clean.
	Incorrect assembly of the braking system.	Assemble correctly.
Load roped while lowering	Damaged friction discs.	Replace with new friction discs.
	Foreign matters in the braking system.	Disassemble and clean.
Load chain binds	Damaged load chain or internal parts.	Disassemble hoist, inspect and repair or replace damaged components.
	Load chain not installed properly (twisted or kinked).	Untwist load chain if possible, or uninstall load chain and re-install.
Hand chain binds	Damaged hand chain, hand chain wheel, or internal parts.	Disassemble hoist, inspect and repair or replace damaged components.
	Hand chain not installed properly (twisted or kinked).	Untwist load chain if possible, or uninstall load chain and re-install.
Noises during hoisting and lowering operation	Wear or deformation of the load chain and load sheave.	Replace with new parts.
Load hook latch does not work	Latch broken.	Replace hook latch.
	Load hook bent or twisted.	Inspect load hook
Load will not go down	The hoist was left under load for extended period.	For non-overload protection chain hoists pulling harder on the chain may loosen brake.
	Over tightened brake.	If load cannot be moved, use another lifting device to remove the load from the affected hoist and replace brake components and perform hoist maintenance.
	Shock loaded during operation.	
	Brake rusted tight.	

SAFETY INSTRUCTION



WARNING Be sure each person reads and understands this manual before operating or maintaining the hoist. The manual hoist must be properly operated and maintained at all times. Do not operate this hoist with any power devices.

DO

01. **DO** read the operation and maintenance instructions.
02. **DO** be familiar with hoist operation controls procedures and warnings.
03. **DO** make sure that the unit is securely attached to a suitable support before applying load.
04. **DO** maintain firm footing or be secured when operating unit.
05. **DO** make sure that load slings or other approved sling attachments are properly sized and seated in the hook saddle.
06. **DO** make sure the hook safety latches are closed and not supporting and part of the load.
07. **DO** make sure load is free to move and will clear all obstructions.
08. **DO** take up slack carefully, check load balance, move the load a few inches, and check load holding action before continuing.
09. **DO** make sure all persons stay clear of the supported load.
10. **DO** avoid swinging of load or load hook.
11. **DO** protect load chain from weld spatter or other damaging contaminants.
12. **DO** promptly report any malfunction, unusual performance, or damage of the unit.
13. **DO** inspect unit regularly, replace damaged or worn parts, and keep appropriate records of maintenance.
14. **DO** use the recommended parts when repairing unit.
15. **DO** apply lubricant to load chain as recommended parts.

DO NOT

- 01.**DO NOT** allow the hook to pass over the heads of people below, whether loaded or not.
- 02.**DO NOT** attempt to move a load greater than the maximum safe load indicated on the equipment.
- 03.**DO NOT** remove the safety clips on the hooks.
- 04.**DO NOT** jam, adjust or remove the end stops in order to increase left or right travel to more than would otherwise be possible.
- 05.**DO NOT** use the equipment for extracting or unjammed purposes or for lateral pulling etc.
- 06.**DO NOT** use the equipment to transport people.
- 07.**DO NOT** touch any moving parts.
- 08.**DO NOT** use the equipment if it is in bad condition(worn,bent etc.).
- 09.**DO NOT** use spare parts of unknown or doubtful origin.
- 10.**DO NOT** intentionally allow the load to tip over.
- 11.**DO NOT** provoke violent impacts with the equipment.
- 12.**DO NOT** constantly use the end stops as a means of stopping.
- 13.**DO NOT** use the lifting chain as a sling.
- 14.**DO NOT** attach a sling on the point of the hook(risk of hook being damaged and load falling).
- 15.**DO NOT** use the hook in a slanting position.
- 16.**DO NOT** twist the lifting chain(risk of pulley block turning over, etc.)
- 17.**DO NOT** leave a load suspended unless absolutely necessary.
- 18.**DO NOT** use the equipment as an earth for welding.
- 19.**DO NOT** use the equipment for a purpose or in a situation for which it is not designed (corrosive atmosphere,...).
- 20.**DO NOT** use the safety devices as a means of measuring laden weight.
- 21.**DO NOT** operate jerkily as this provokes deterioration of the equipment.
- 22.**DO NOT** pull the load sideways, bring the equipment to a position above the load before moving it.
- 23.**DO NOT** reach the lowest point.

Criteria for use

- 1 .Make sure that the class of the chain hoist is fit for condition of it's use.
- 2.The chain hoist should not be used to lift a load exceeding the rated load except for testing purpose.
- 3.Do not use a bottom hook which is not equipped with a safety latch or of which latch has no safety effect.
- 4.Do not use chain block on which chain stoppers are missing.
- 5.Do not wind the load chain directly around a load.
- 6.Do not quickly pull the hand chain on lifting and lowering operation.
- 7.Do not perform over-lifting and over-lowering.
- 8.Avoid an operation of so-called earth lifting.
- 9.Before operation check the load chain for twisting or tangling.
- 10.Can be used only after such twisting and tangling are corrected.
- 11.When the chain hoist is used in special conditions such as lower or higher temperatures, or corrosive atmosphere, etc.,consult us before use.
- 12.The chain hoist should not be modified by the users.
- 13.Do not leave the chain hoist for many hours with a load suspended.
- 14.Make a routine inspection before use.
- 15.Immediately stop operation the chain hoist when an abnormally big pulling for the hand chain is required.
- 16.Apply a lubricant to the load chain before use.
- 17.Use the chain hoist, applying lubricants to its gears, bearings, which are liable to wear.
- 18.Consult us whenever special usage of the chain hoist is required.

INSPECTION

In order to maintain quality operation of the product, a regular inspection schedule should be set up by each operator. All inspections should be reported and maintained in a dated record log. These records should be available to all personnel involved with the product, and should be available when a warranty issue is in question.

Definitions

The following definitions are from the EN13157 and will be used in the inspections procedure that follows.

Inspection Classifications

"Initial inspection should be done on all new, modified, and repaired products in accordance with Table 1. Thereafter, items to be inspected are indicated in Table 1 by F (Frequent) or P (Periodic). For hoists exposed to more severe environmental conditions inspections should be more frequent. "

Frequent Inspections

"The operator or other designated person performs frequent inspections by doing a visual examination and by listening for unusual sounds while product is operating. Frequent inspections are usually performed on the following schedule: Normal Service- Monthly inspections Heavy Service- Weekly to monthly inspections Severe Service- Daily or before each use to weekly inspections "

Periodic Inspections

"Designated person performs periodic inspections, which are more detailed inspections, by doing visual examinations of external and internal conditions. These inspections are done on the following schedule: Normal Service- Yearly inspection Heavy Service- Semi-annually inspections Severe Service- Quarterly inspections "

The methods for maintenance and inspection

Do not use parts and the chain hoist over the limit of use. If any wearing parts are found in excess of the standard limit of use as stated below in carrying out the daily and periodic voluntary inspections, they should be replaced for sure. Daily and periodic voluntary inspections, they should be replaced for use.

When replacing load chains, be sure to use the load chain manufactured by us. Load chains manufactured by any others are not applicable.

Checking the load chain and its lifetime

The load chain begins to be broken from even one pieces of weak chain links and thus it is important to carefully inspect the whole chain. For checking the elongation, measure the inner length of 5 links with a vernier caliper as the above sketch shows. It is normally sufficient to check the links in a distance of approx. Every 50cm but check them by making the measuring distance shorter when the elongation of the chain is close to the limitation for use started in Table 2 so that none of them will exceed the limitation for use.

Exchange the load chain with a new one which is found by visual check to be clearly deformed. Furthermore, do not weld a load chain to the original one by users themselves.

Limitation of the deformed load chain for use (Table 2)

Rated load(kg)	Link diameter-P×5mm (new chain)	Limitation of P×5 (mm) for use
500	φ6*80	81.6
1,000	φ6*80	81.6
1,500	φ8*120	122
2,000	φ8*120	122
2,000	φ6*80	81.6
3,000	φ8*120	122
5,000	φ10*150	152
10,000		
20,000		

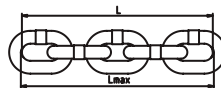

Table 2

TABLE 1-INSPECTION CHART

In chart, F indicates Frequent Inspection, P indicates Periodic Inspection

LOCATION		CHECK FOR	F	P
Braking mechanism		Slipping under load	✓	
		Hard to release	✓	
Brake parts	Brake Discs	Glazing		✓
		Oil contamination		✓
	Pawl:Ratchet	Excessive wear		✓
	Pawl:Spring	Corrosion:Stretch		✓
Hook		Chemical damage	✓	
		Operation	✓	
		Deformation	✓	
		Crakes(dye penetrant, magnetic particle, or other suitable detection method)		✓
Hook retaining members not tight or secure (Pins, Bolts, Nuts)		Not tight, Secure or damaged		✓
Hook Latch		Damaged; does not close	✓	
Suspension Members (Sheaves, Hand-wheels, Chain attachments, Suspension bolts or pins)		Excessive wear		✓
		Crakes	✓	✓
Gears		Distortion		✓
		Broken or worn teeth		✓
		Crakes		✓
		Inadequate lubrication		✓
Load Block:Suspension housing		Distortion	✓	✓
		Crake	✓	✓
Trolley:Supporting structure		Possible inability to continue supporting loads or damaged		✓
Bolts, Nuts, Rivets		Not tight or secure		✓
WARNING Labels		Removed or not legible	✓	
Proper operation		Unusual sounds	✓	

Table1

MAINTENANCE

Lubrication

Proper lubrication with machine oil is necessary to increase the life of the chain. Lubrication should be done based on usage and on a regular basis. It may be necessary on a weekly basis for heavy use or monthly if used less often.

- Clean the chain with an acid free cleaning solution to remove debris.
- Apply oil to chain focusing on bearing surfaces such as interlink areas.
- Do not apply oil to braking surfaces.
- Gears and shafts run on roller bearings and do require lubrication.

BRAKE & TOP HOOK INSPECTION & REPLACEMENT

Disassembly

- Remove the cover using a standard socket wrench.
- Remove the hand chain from the wheel.
- Use needle nose-pliers to straighten the cotter pin.
- Remove nut.
- Remove secondary cover (protects the brake).
- Remove brake
- To disassemble the top hook remove the pin and the hook comes off.

Assembly

- Chain should be well seated in the wheel.
- Put the hand wheel back on.
- Should hear a click, indicating the brake is set.
- Hand tighten the nut.
- Push the cotter pin back in.
- Use pliers to flare the ears so it stays in place.
- Reattach the hand chain; making sure the weld is out.
- Attach cover and tighten locknuts.

Storage of Hoist

- Store the hoist in a clean dry area.
- Maintain proper lubrication of the hoist while it is being stored.
- If the hoist is malfunctioning clearly mark it before placing it in storage.

Outdoor Hoist Usage

- Store hoist indoors when not in use.
- Frequently inspect the hoist for signs of corrosion due to environmental factors.