

吊卡刀版图

Ø6mm [Ø0.2"]

139mm [5.5"]

109mm [4.3"]

OPERATING INSTRUCTIONS

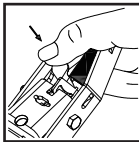

TO APPLY TENSION, engage the drive lever by pushing the shift lever (located above the drive lever) rearward until the spring is seated in the alt detent. Pivot handle assm back & forth to rotate ratchet wheel and take-up line tension.

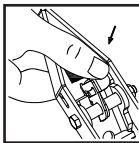

TO RELEASE TENSION, disengage the drive lever by pushing the shift lever forward until the spring is seated in the front detent. Pivot the handle forward until the drive & stop levers are in contact. Continue to apply pressure against the stop lever until it releases and then allow the handle to pivot back. Repeat this procedure to safely release the load a notch-at-a-time.

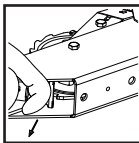

TO FREEWHEEL SPOOL, release all of the line tension, manually disengaged the stop lever by pulling back on the exposed wire loop and unreel the desired length of cable.

For replacement parts and technical questions, please contact Customer Service at 1-888-380-7428

X-POWER[®]

WEB-STRAP HOIST/PULLER

Model Number:10810004

- 2,000 LB. Lift Capacity
- 4,000 LB. Pull Capacity
- 4 ft Double Line
- 1 Inch Wide Webbing

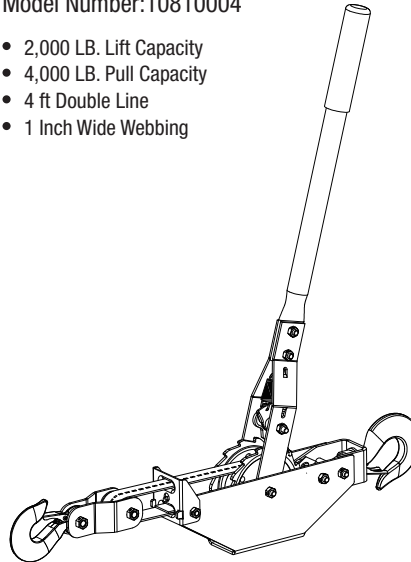

吊卡刀版图

Ø6mm [Ø0.2"]

139mm [5.5"]

109mm [4.3"]

USE CONSIDERATIONS WITH NYLON WEBBING

HEAT: Nylon webbing is not suited for use in environments above 180°F.

EXPOSURE: Nylon webbing is adversely affected by prolonged exposure to extreme ultraviolet light, such as direct sunlight and arc welding.

CHEMICALS: Nylon webbing is not compatible for use in the presence of vapors, mists, sprays, or liquids of acids, phenolics, or bleaching agents.

Your X-POWER Webbing Hoist/Puller utilizes nylon webbing with red safety indicating cores inside. These threads are positive indicators that the webbing has been damaged. If for any reason these red cores are outwardly visible, discontinue use of the puller. Possible reasons for damaged webbing and discontinued use include the following:

- Broken or worn stitching at attachments
- Excessive abrasions
- Acid or alkali burns
- Melted or charred sections
- Punctured, cut, or snagged sections

CAUTIONS

- Read and understand all instructions before using.
- Inspect mechanism and cable/webbing for proper operation and condition before each use.
- Know your loadings; do not exceed rated capabilities.
- This product is intended for straight-in-line lifting and pulling do not side load mechanism or cable/webbing.
- Do not shock load mechanism or cable / webbing.
- Always keep a minimum of two wraps of cable or one wrap of webbing on the hub while mechanism is under load.
- Always use puller under manual Power; do not use in place of tow line.
- This product is not recommended for use a load binder or tie-down.
- Handle is designed to bend if overloaded; do not use an extension bar on the handle.
- Never stand in from of, or in line with a pretensioned mechanism.
- Do not use to lift people or loads overhead.
- Do not operate hoist/puller with twisted, frayed, damaged or kinked cable/webbing.
- Do not pull cable/webbing over sharp corners or secure hook back onto cable.

WARRANTY

"Limited 90 Day Warranty to Original Using Buyer"

All X-POWER Hoist Pullers are warranted for 90 days against defects when operated under normal conditions, within their rated capacities and in accordance with the operating instructions and use considerations.

This warranty does not apply to damage due directly or indirectly, to misuse, abuse, negligence or accidents, repairs or alterations outside our facilities, criminal activity, improper installation, normal wear and tear, or to lack of maintenance. We shall in no event be liable for death, injuries to persons or property, or for incidental, contingent, special, or consequential damages arising from the use of our product. Some states do not allow the exclusion or limitation of incidental or consequential damages, so the above limitation of exclusion may not apply to you. THIS WARRANTY IS EXPRESSLY IN LIEU OF ALL OTHER WARRANTIES, EXPRESS OR IMPLIED, INCLUDING THE WARRANTIES OF MERCHANTABILITY AND FITNESS