

SOJAG

produits saisonniers • seasonal products

QUESTIONS? 1 866-901-1649

Assembly Manual / Guide d'assemblage / Manual de ensamblaje / 조립설명서 / Montageanleitung

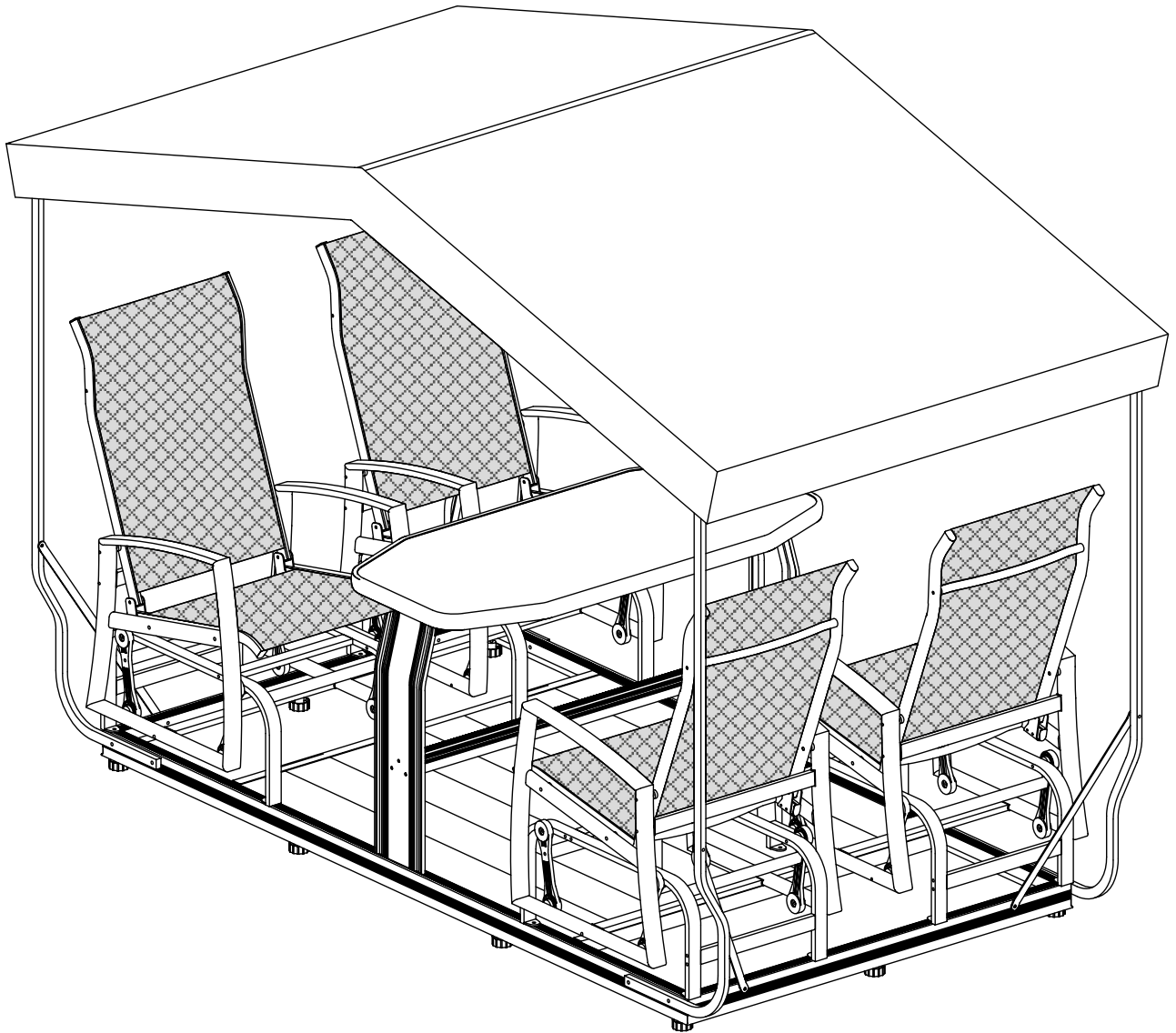

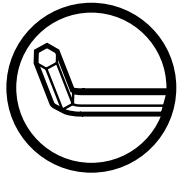

Use the hex keys in the box. / Utilisez les clés hexagonales fournies dans la boîte. / Utilice las llaves hexagonales en la caja. / 상자에 육각 키를 사용 하십시오. / Verwenden Sie die Sechskantschlüssel in der Box.

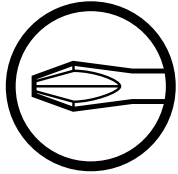

Please use a Phillips screwdriver. / Utilisez un tournevis de type Phillips / Por favor, use un destornillador Phillips. / 십자 드라이버를 사용 하십시오. / Bitte verwenden Sie einen Kreuzschraubenzieher.



You may need to use a drill for this step. / Vous pouvez avoir besoin d'utiliser une perceuse pour cette étape. / Puede que tenga que utilizar un taladro para este paso. / 이 단계에선 드릴을 사용해야 할 수도 있습니다. / Für diesen Schritt können Sie einen Bohrer verwenden.



Wearing protective gloves is recommended. / Le port de gants de protection est recommandé / El uso de guantes de protección se recomienda. / 보호 장갑을 착용 하는 것이 좋습니다. / Das Tragen von Schutzhandschuhen wird empfohlen.



Two or more people are required at this stage. / Deux personnes ou plus sont nécessaires à cette étape. / Dos o más personas se requieren en esta etapa. / 이 단계에서는 두 명 이상 이 필요합니다. / Für diesen Bauschritt sind 2 oder mehr Personen erforderlich.



Do not tighten screws all the way for now. / Ne pas visser fermement pour l'instant. / No atornille con firmeza por ahora. / 아직 나사를 단단히 조이지 마십시오. / Bitte die Schrauben zum jetzigen Zeitpunkt noch nicht fest anziehen.

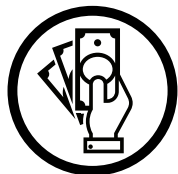

Sold separately. / Vendus séparément. / vendido en las opciones. / 옵션 판매 / Optional erhältlich

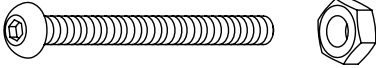

Optional step / Étape optionnelle / Paso opcional / 선택적 단계 / Optionaler Schritt

1 X 16 (+2) 

2 X 8 (+1) 

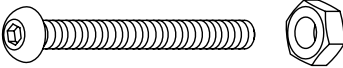
3 X 8 (+1) 

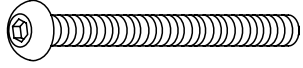
4 X 16 (+2) 

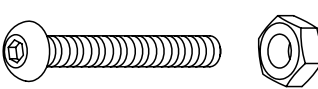
5 X 8 (+1) 

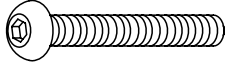
6 X 16 (+2) 

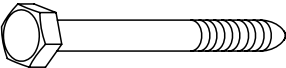
7 X 4 (+1) 

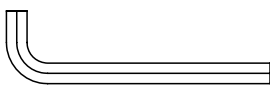
8 X 1 

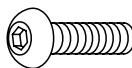
9 X 4 (+1) 

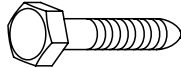
10 X 4 (+1) 

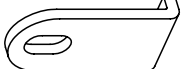
11 X 4 

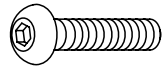
12 X 46 (+4) 

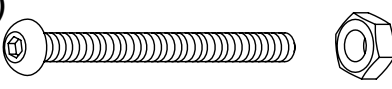
13 X 16 (+2) 

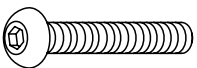
14 X 8 (+1) 

15 X 4 (+1) 

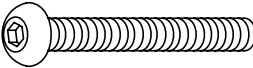
16 X 36 (+3) 

17 X 24 

18 X 2 

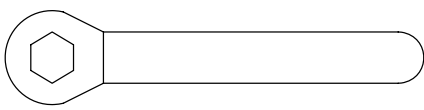
19 X 1 

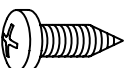
20 X 2 (+1) 

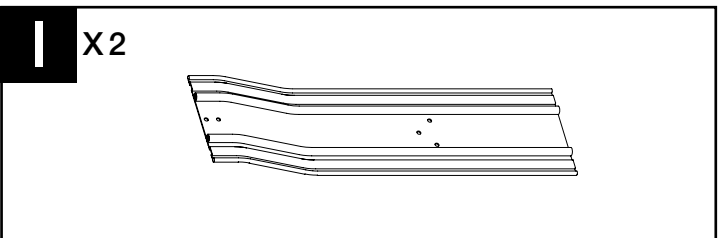
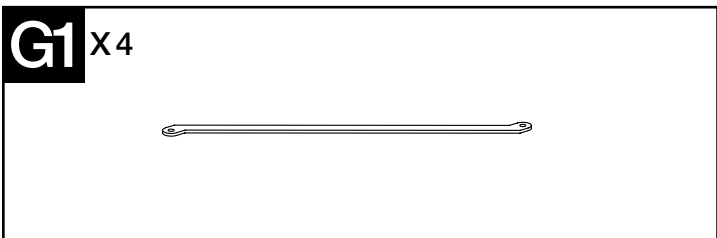
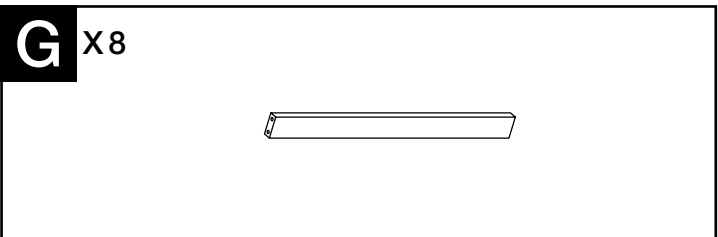
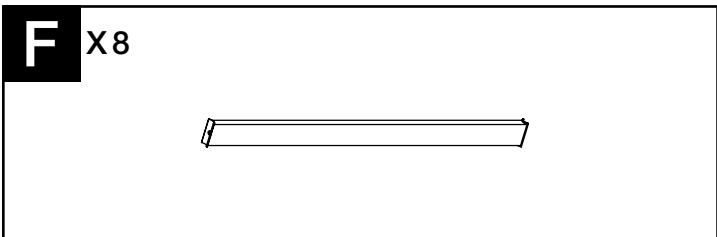
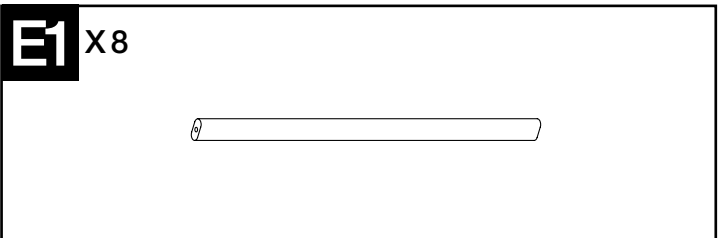
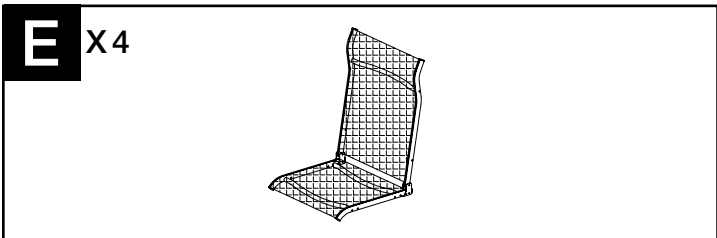
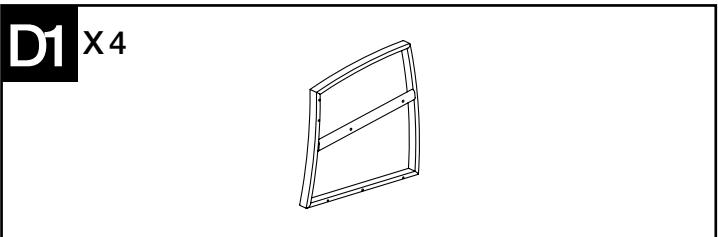
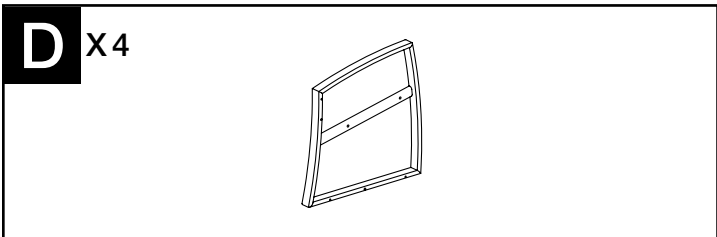
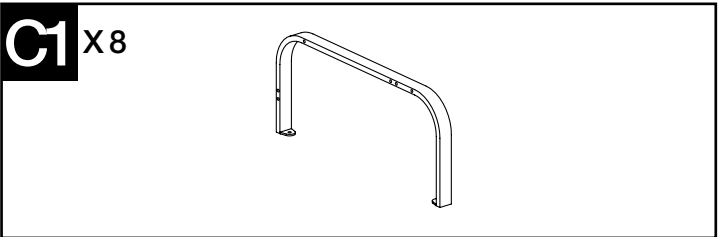
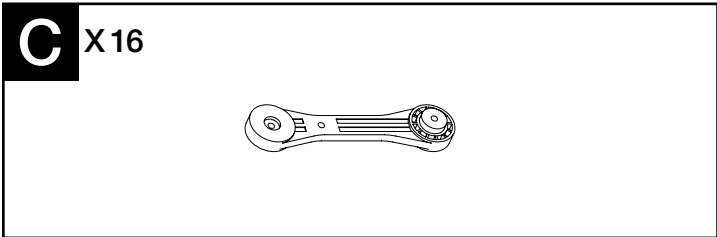
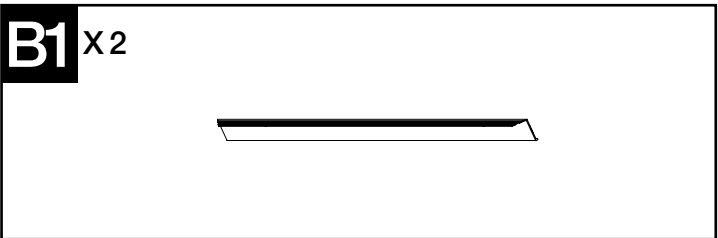
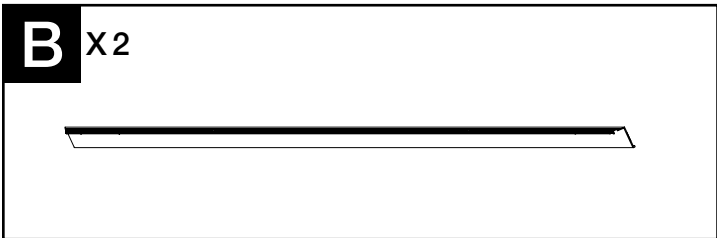
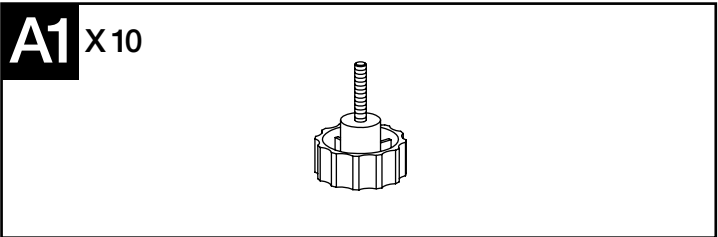
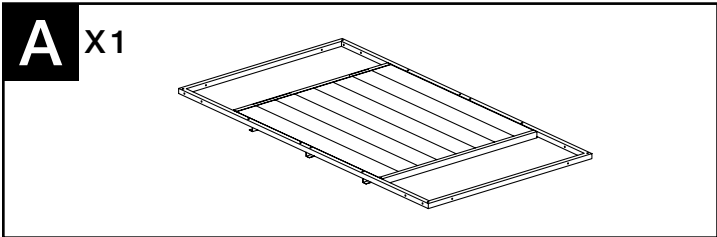

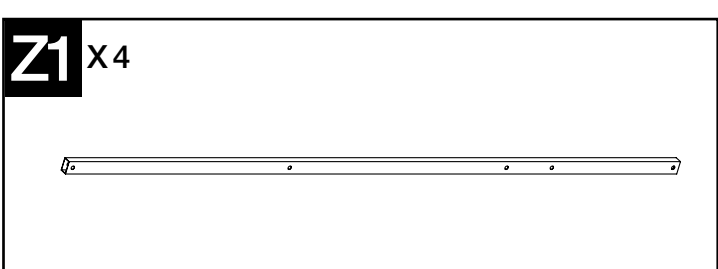
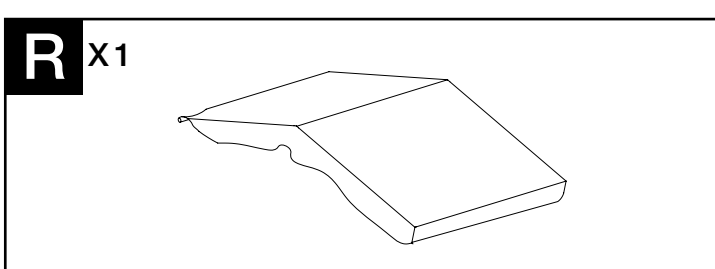
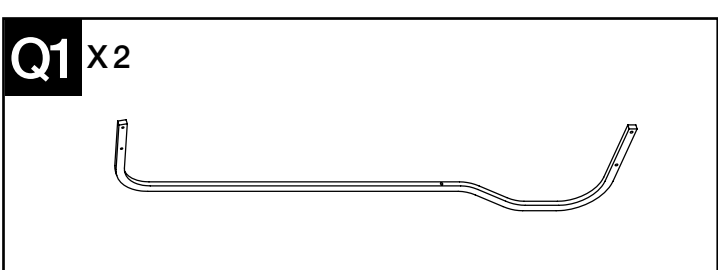
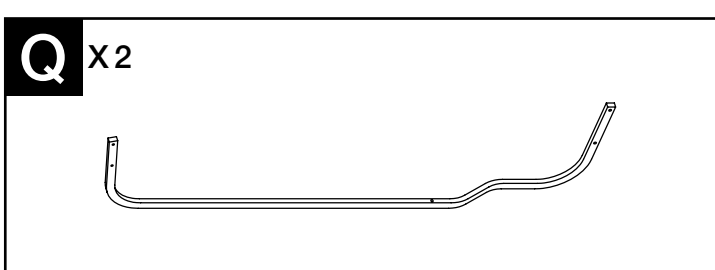
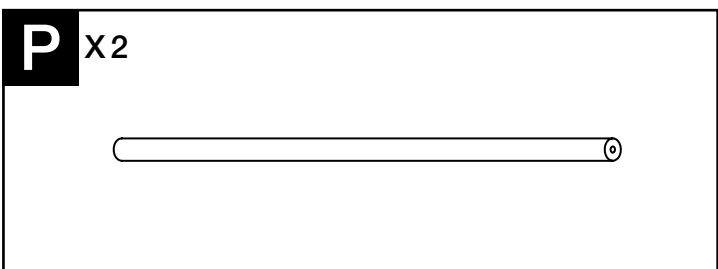
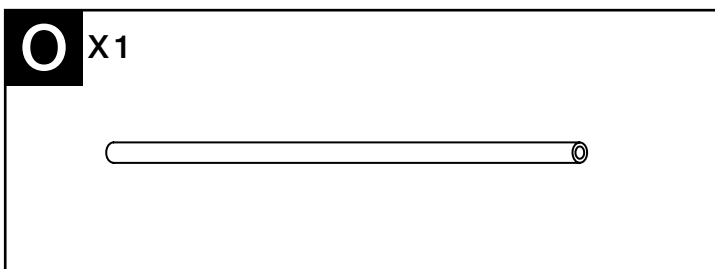
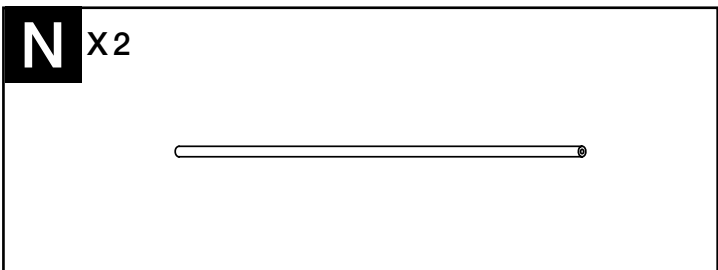
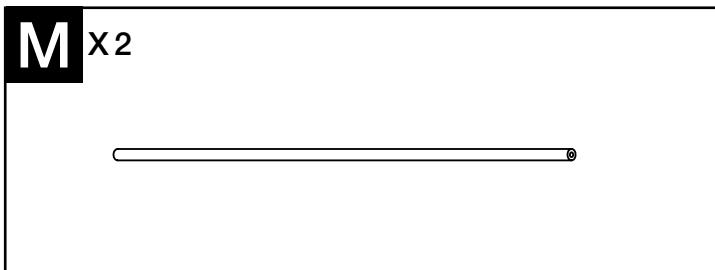
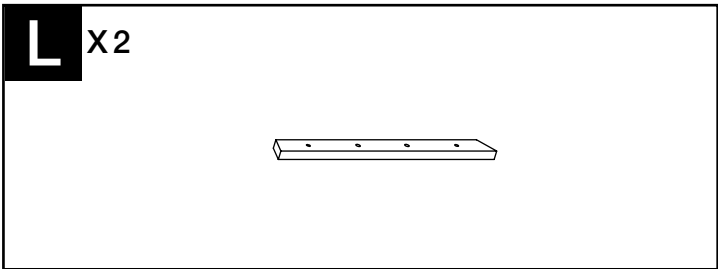
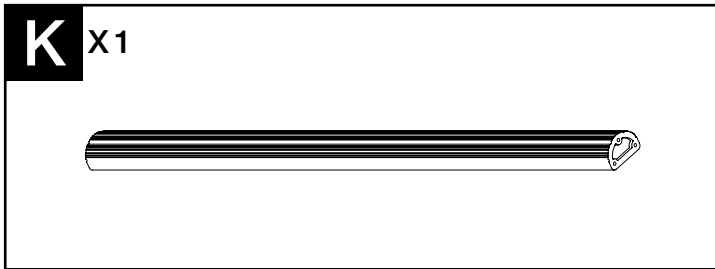
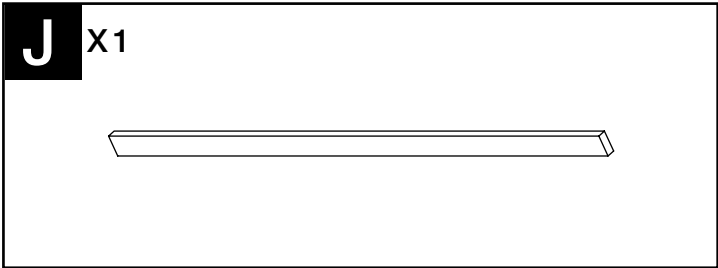
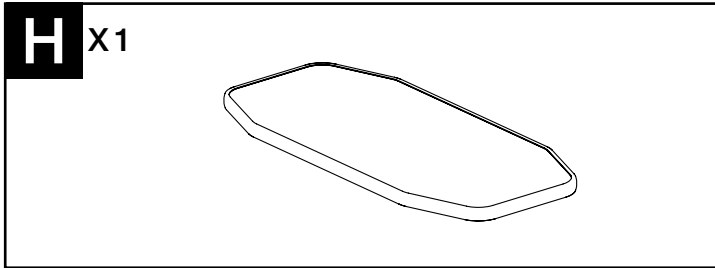

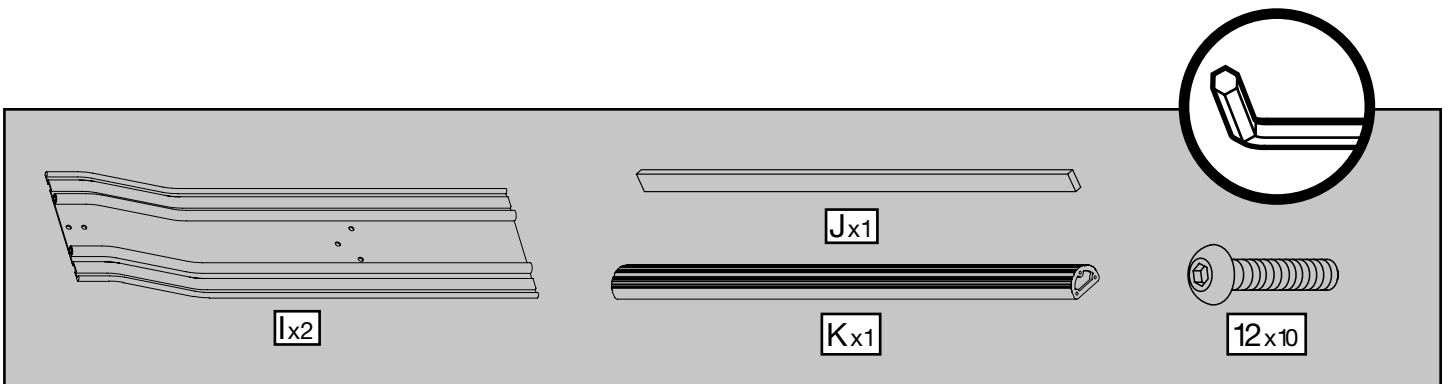
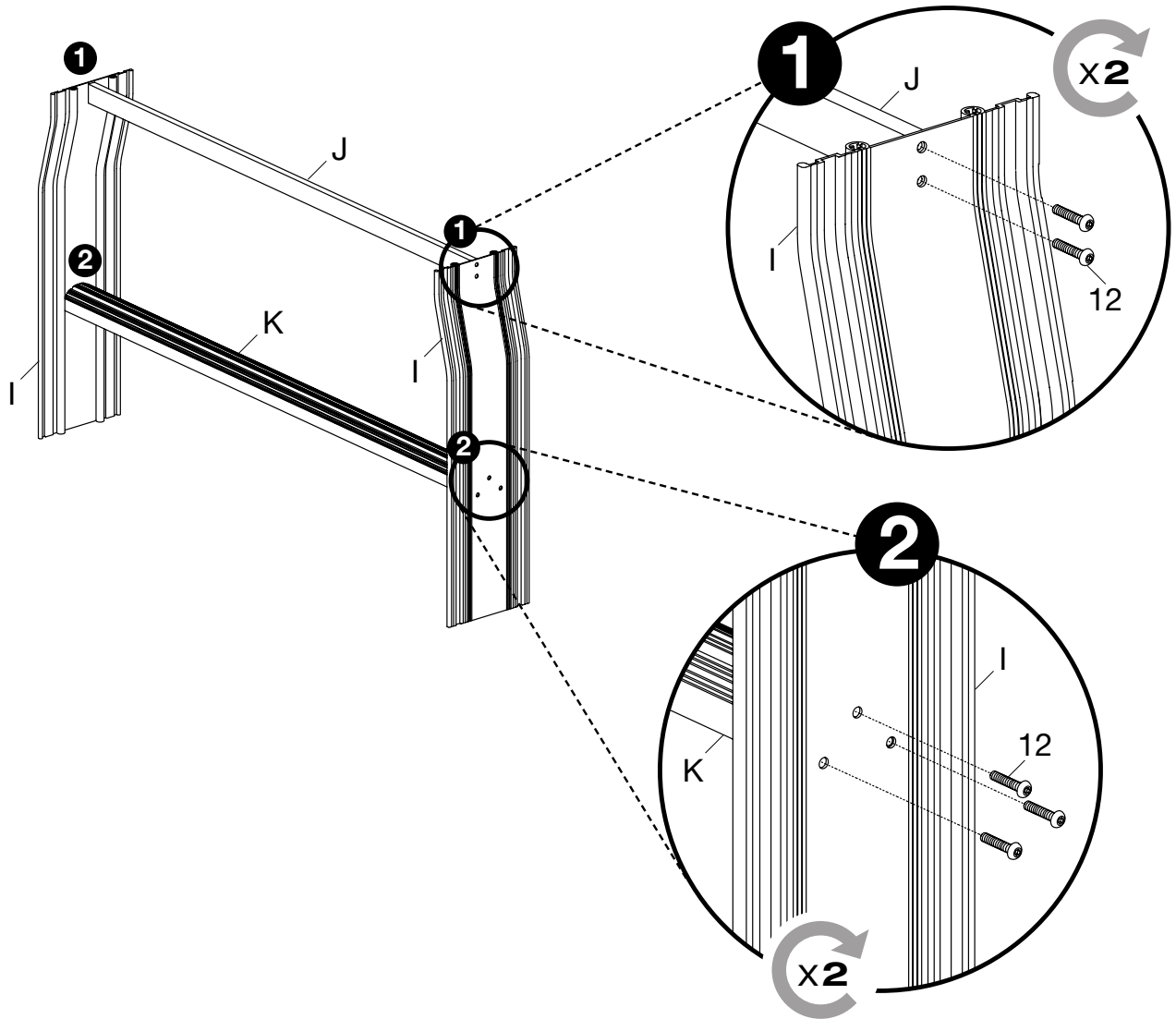

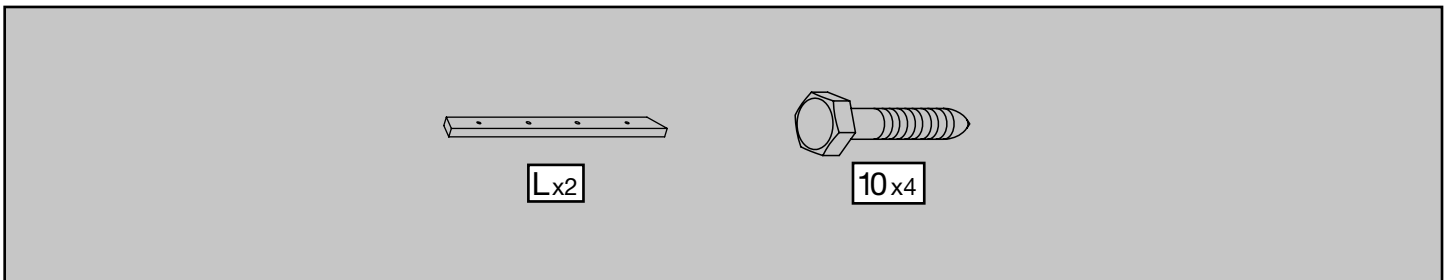
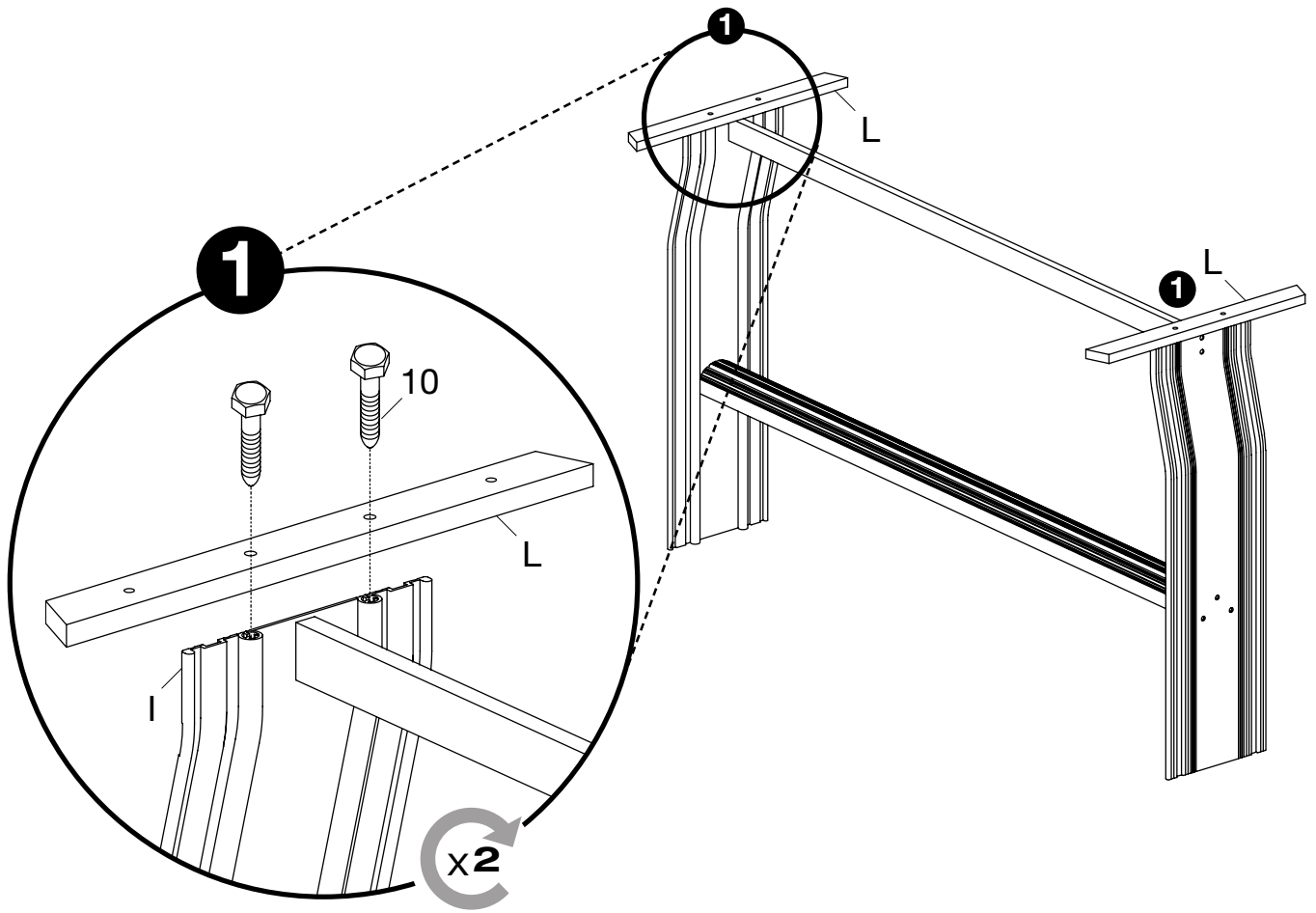

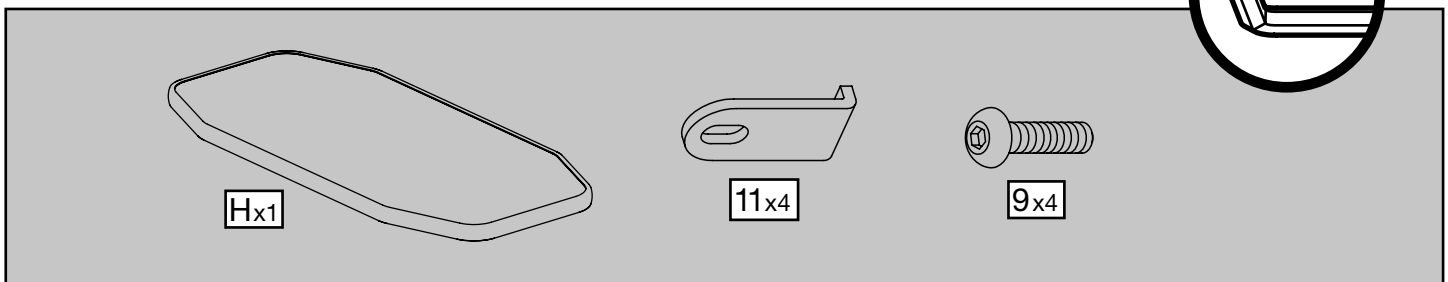
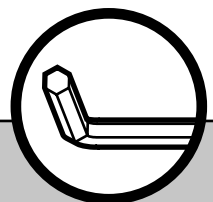
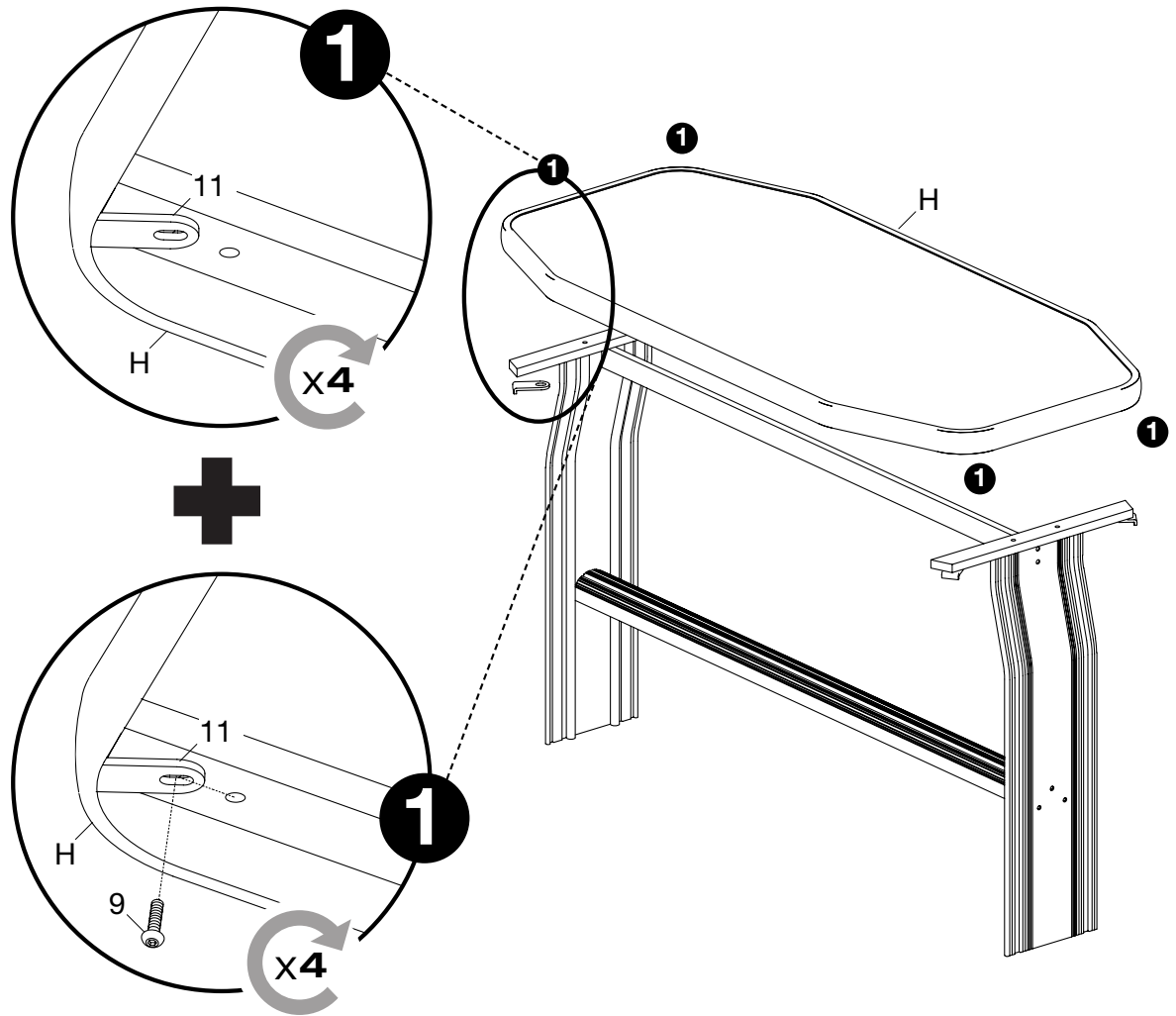

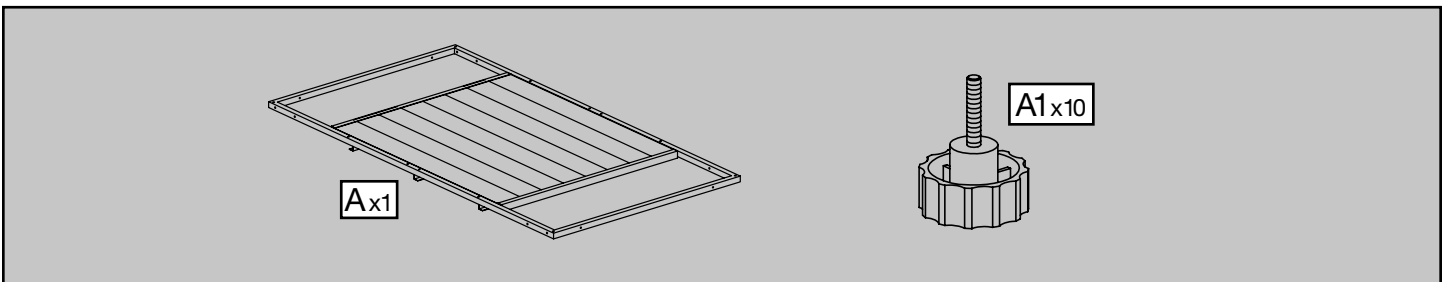
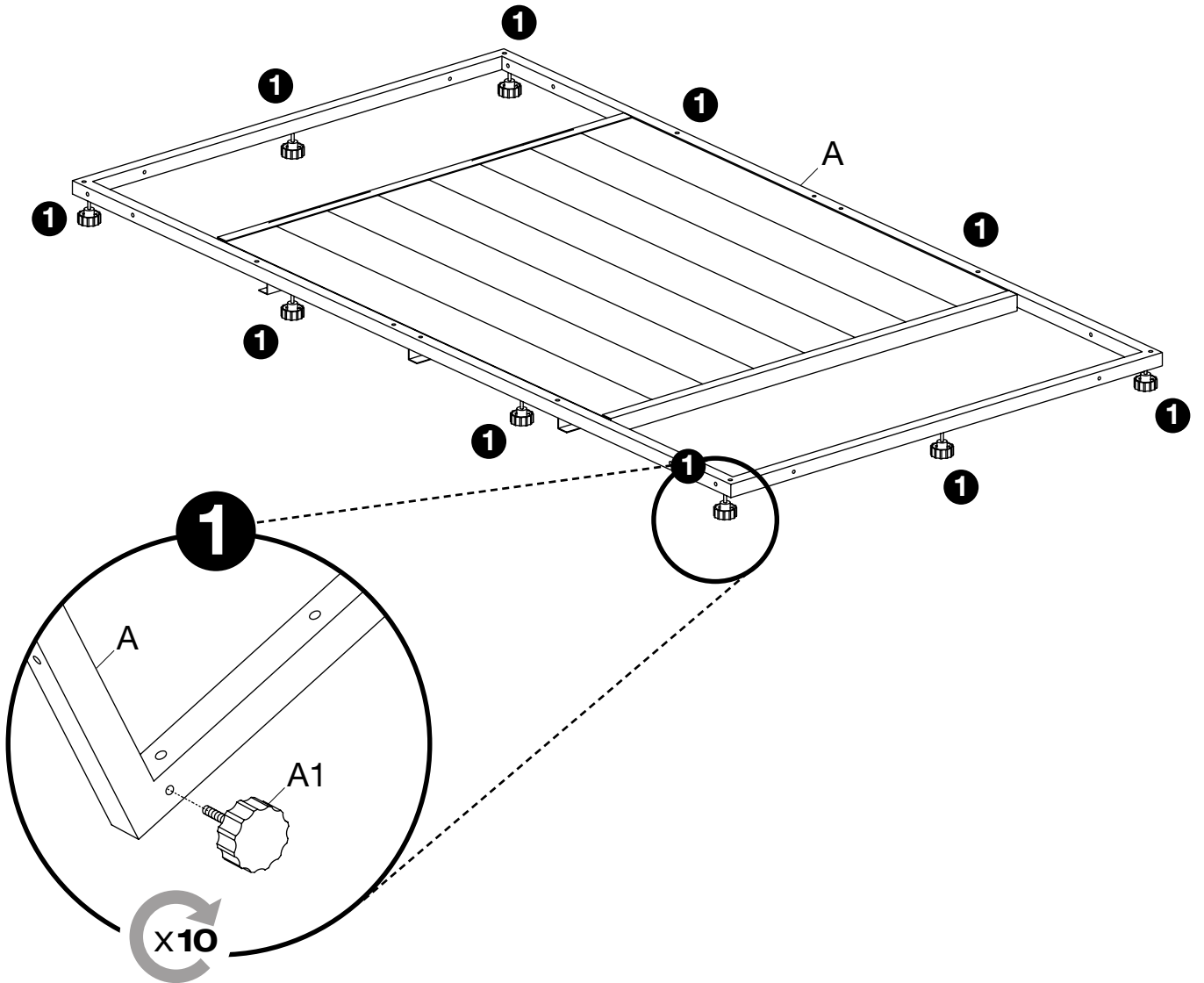

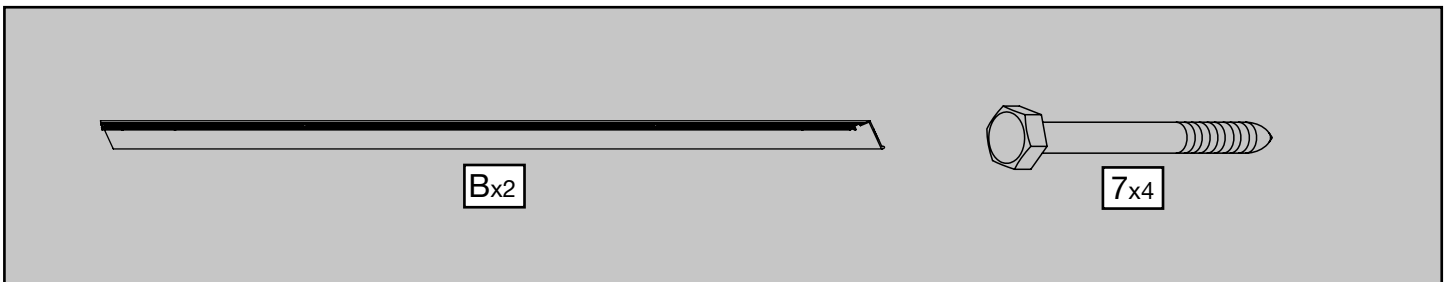
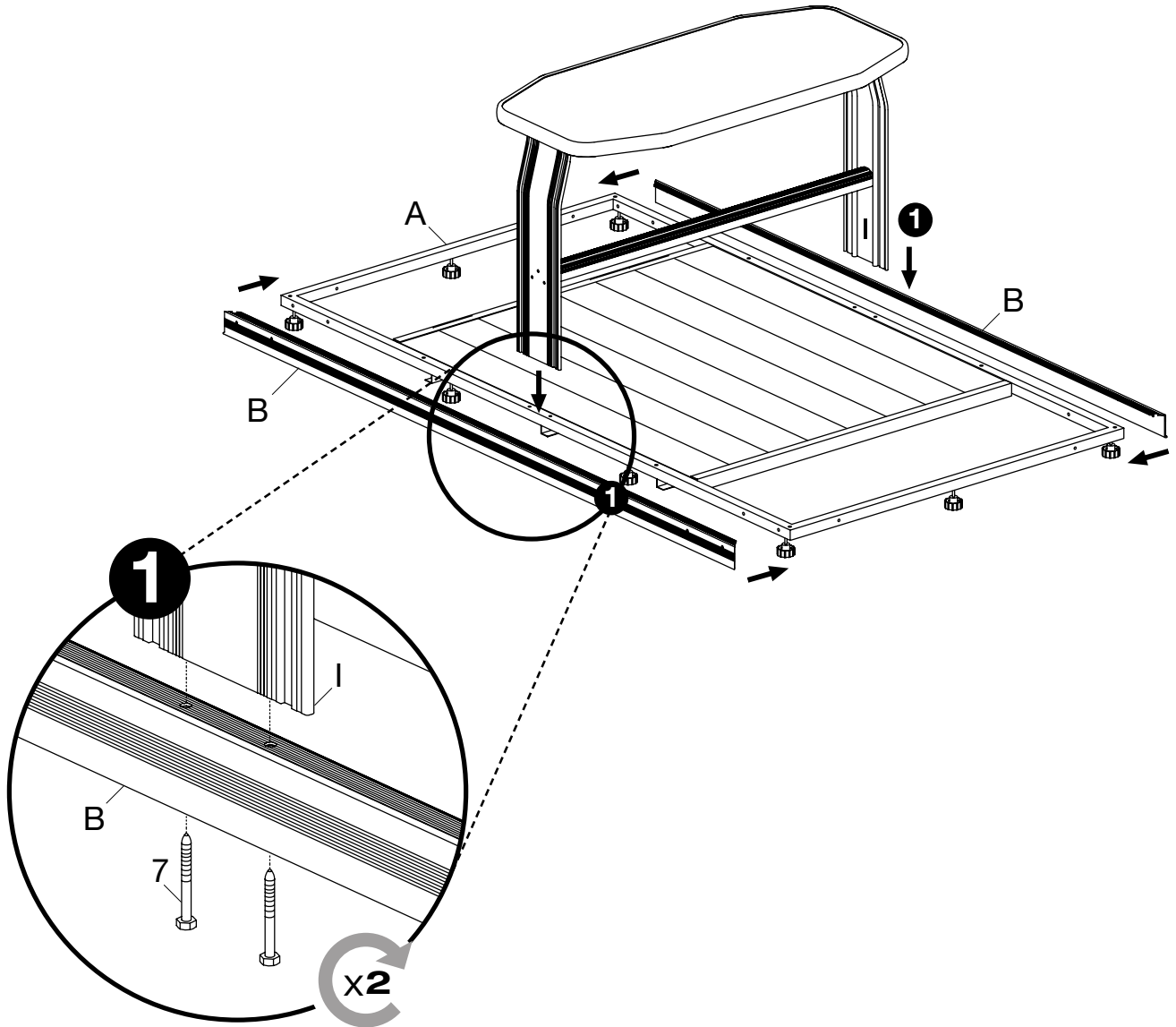

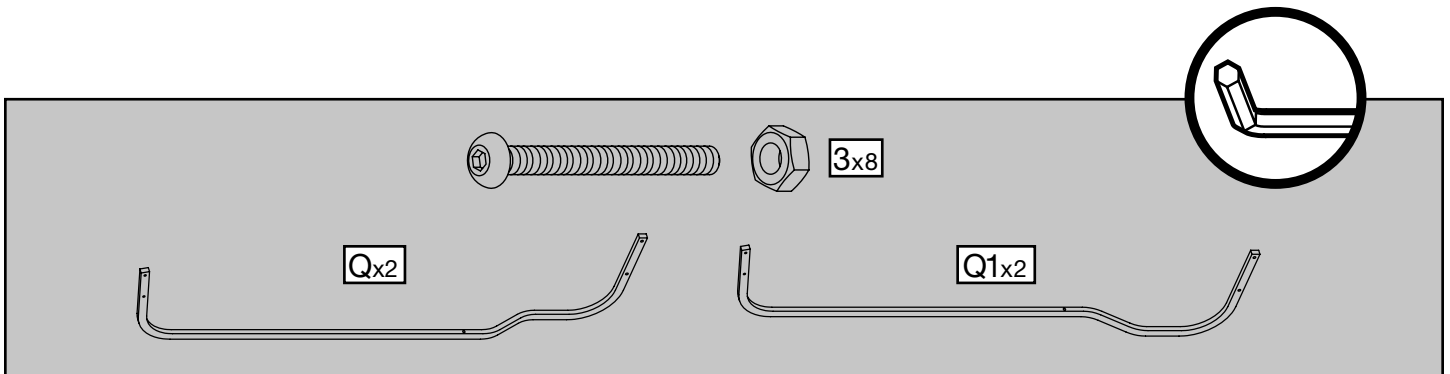
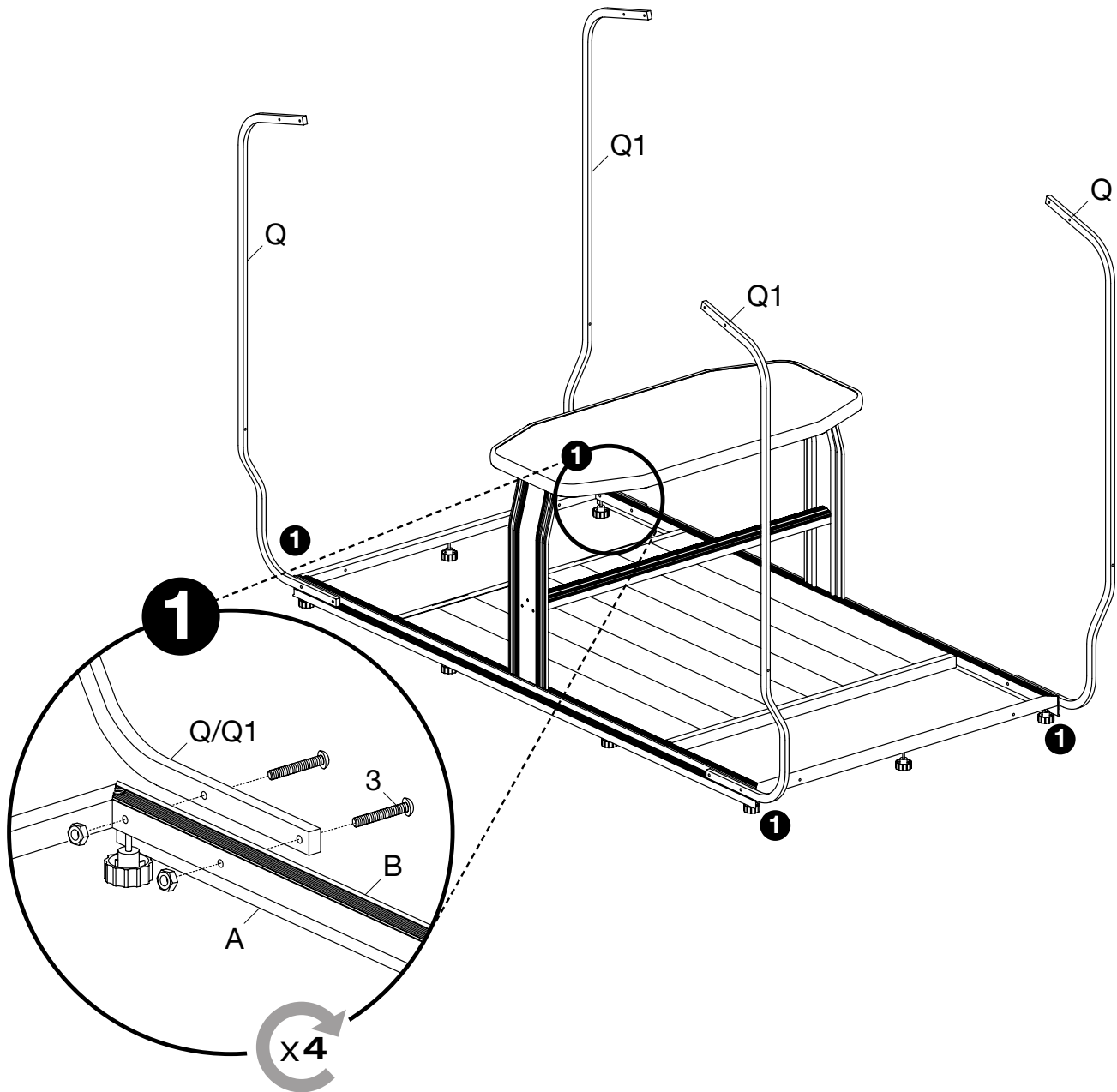

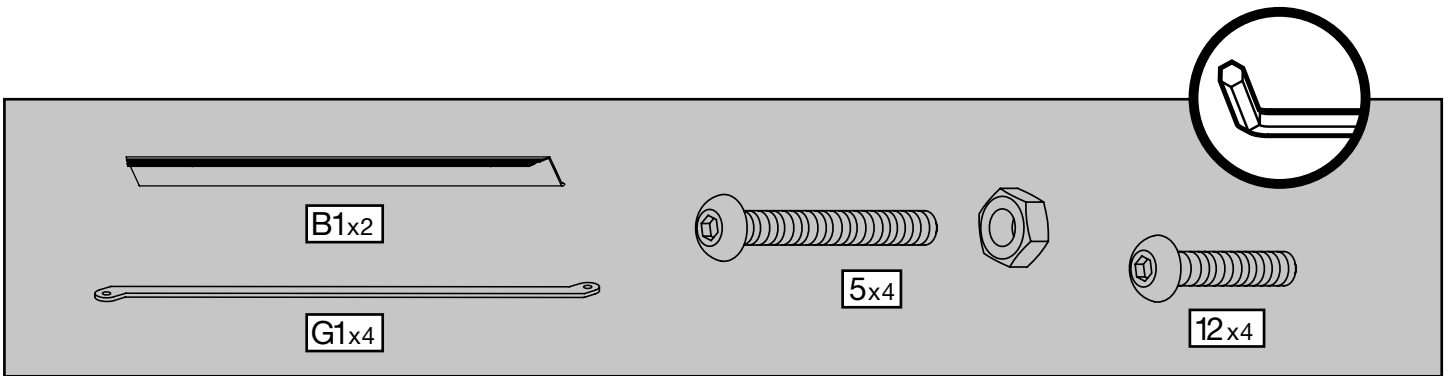
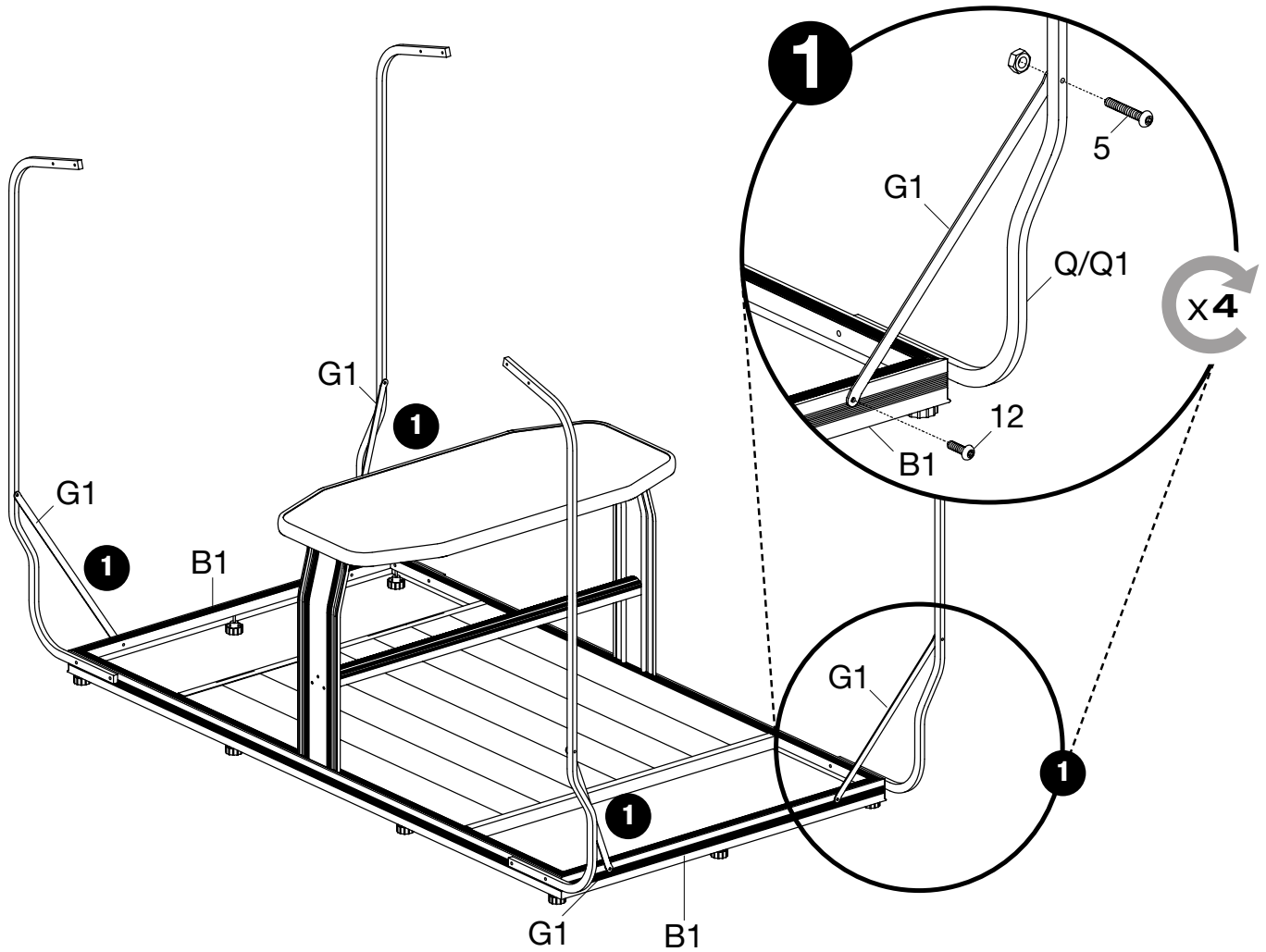

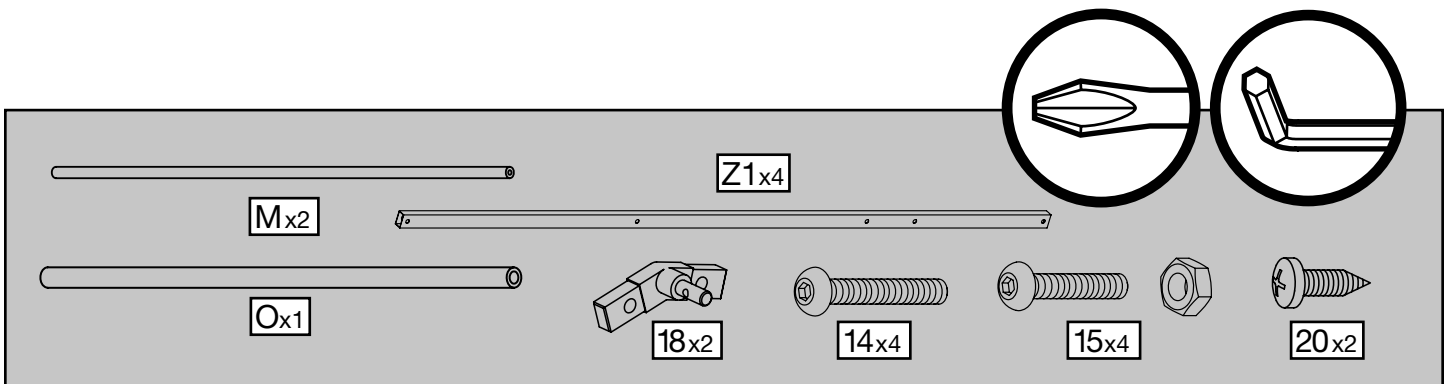
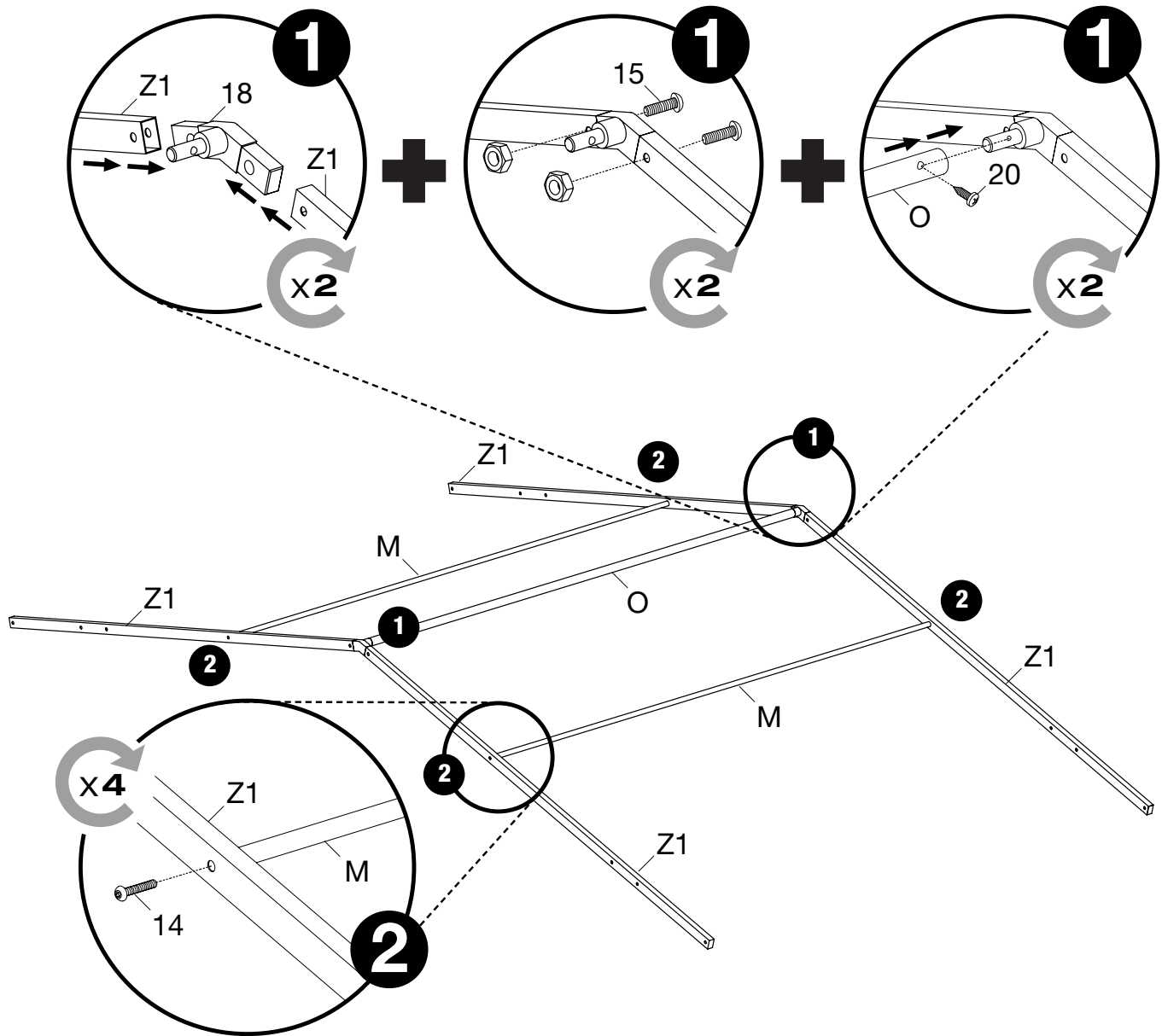

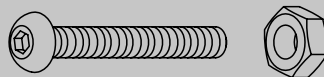
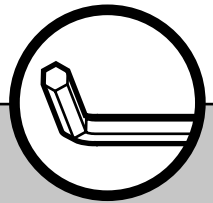
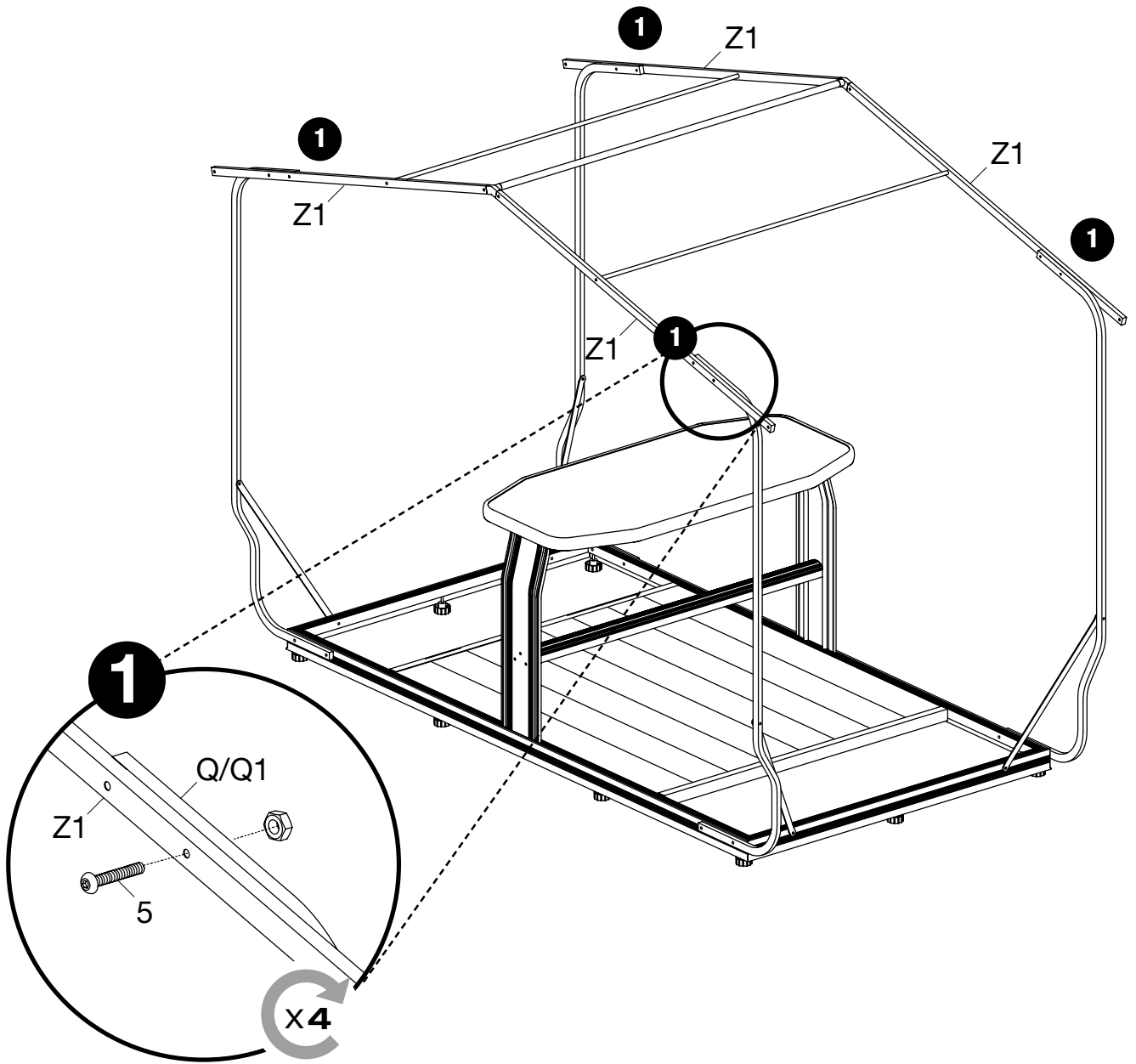

5x4

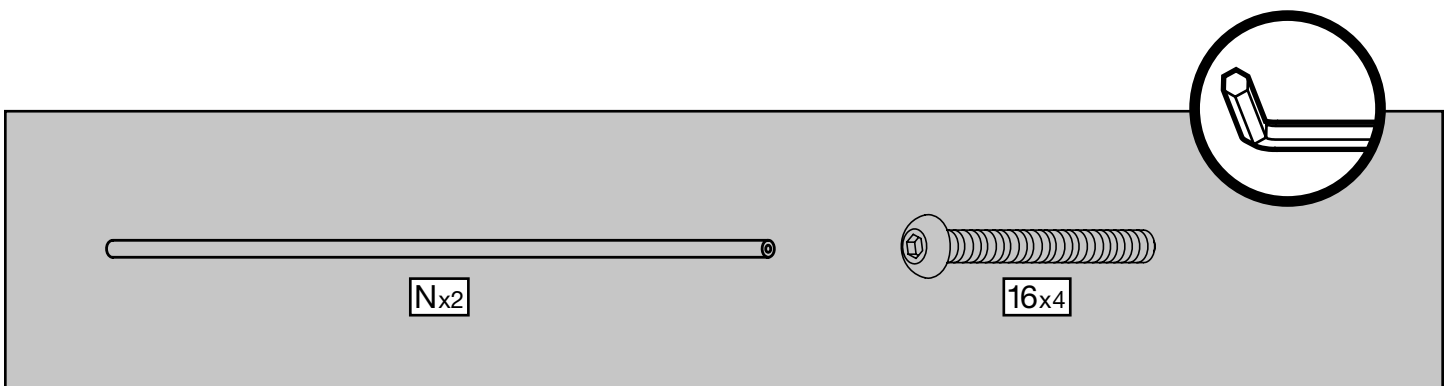
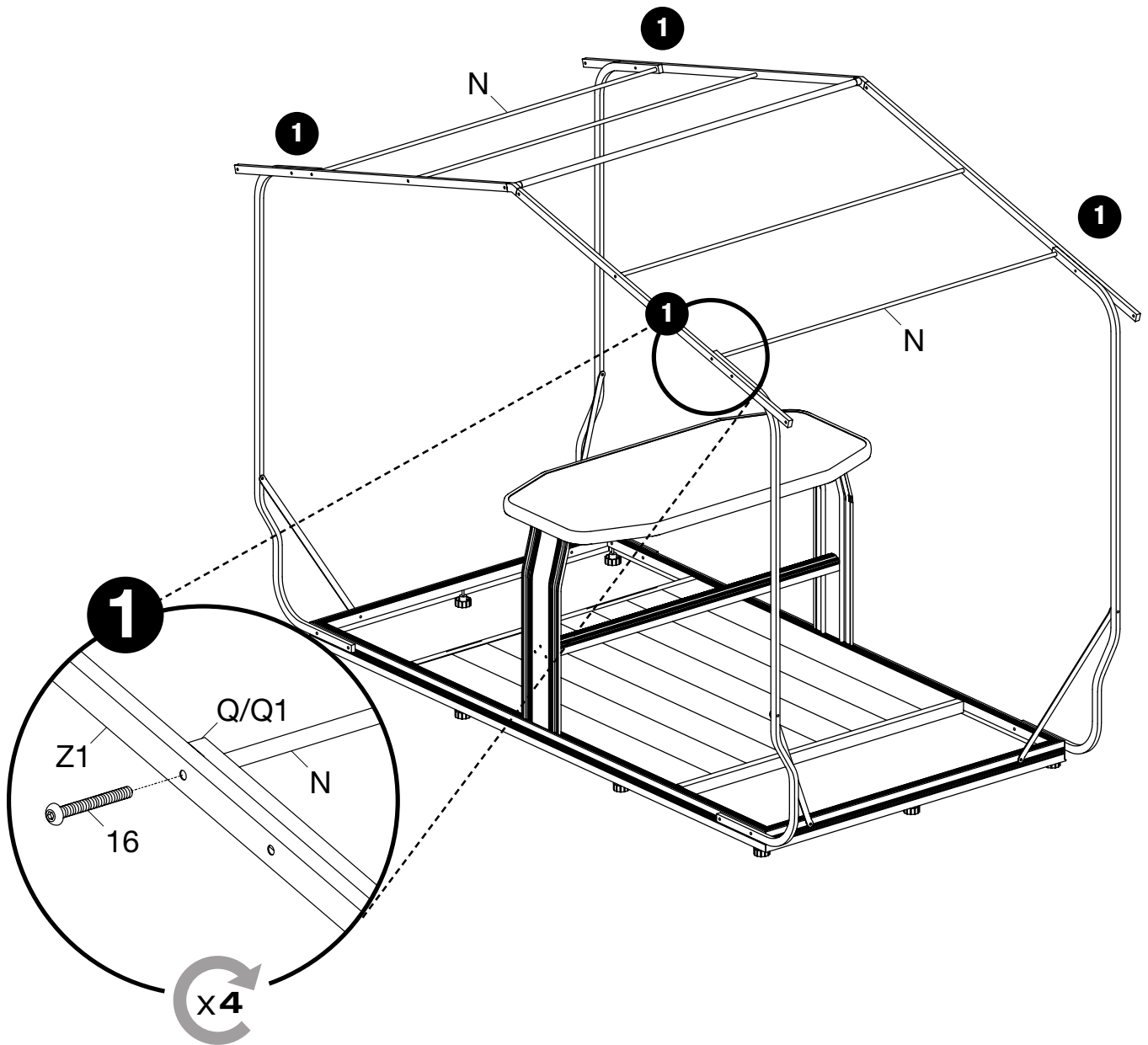

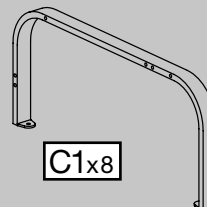
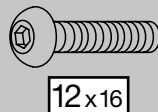
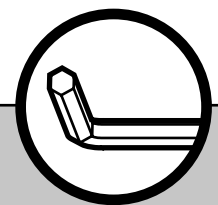
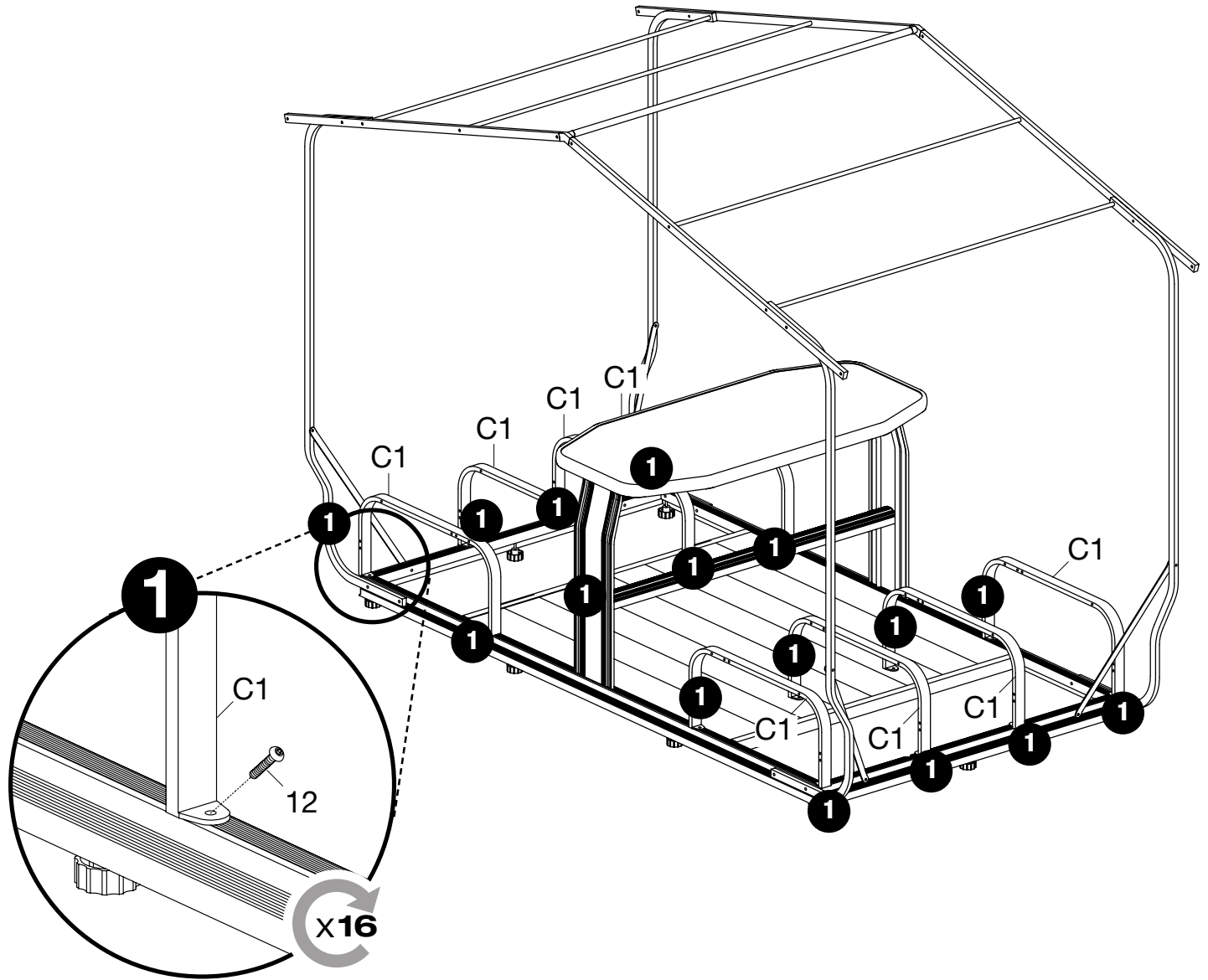

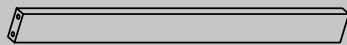
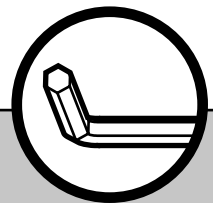
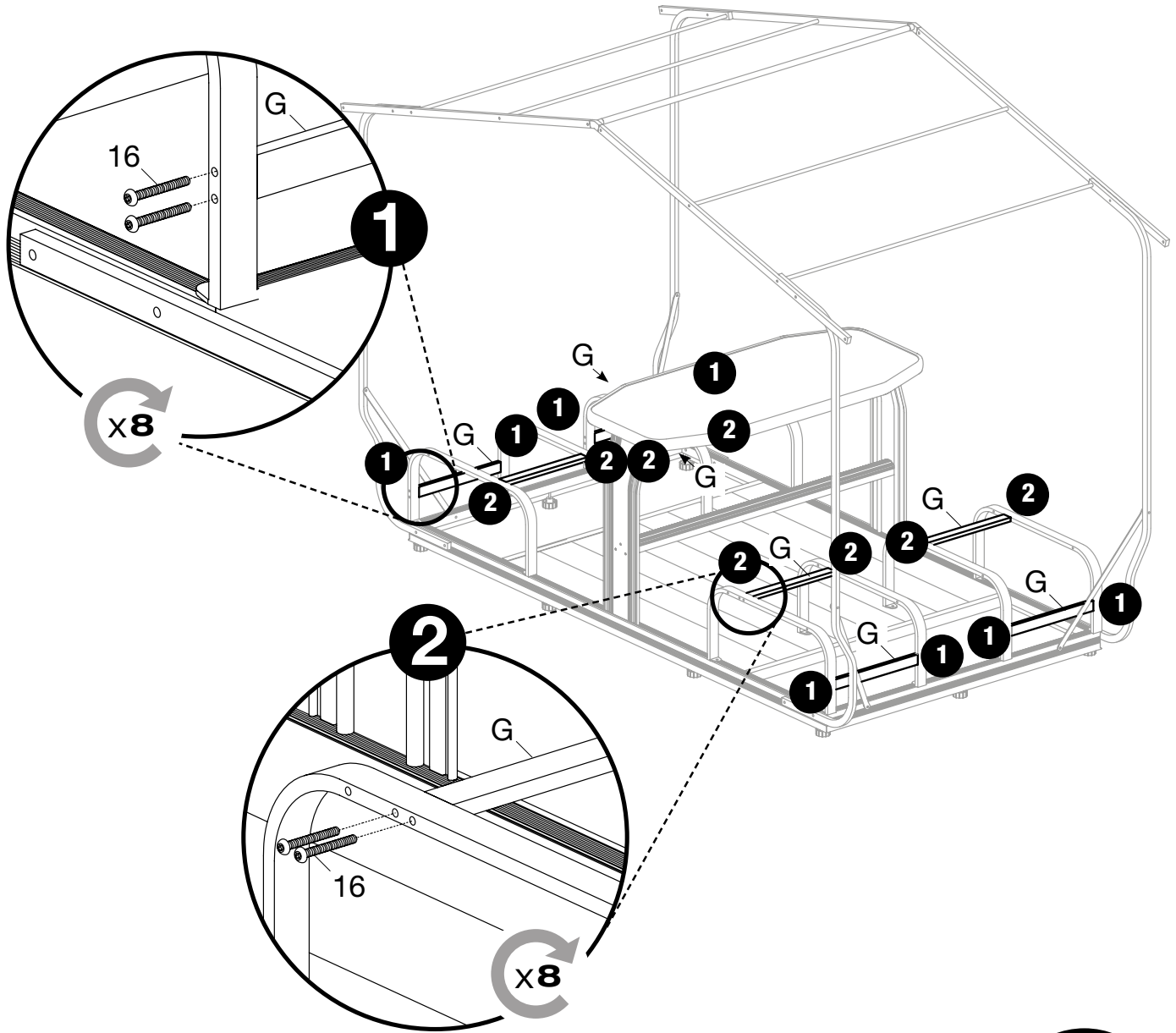

Gx8

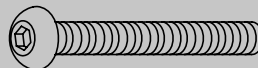

16x32

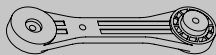
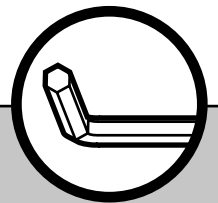
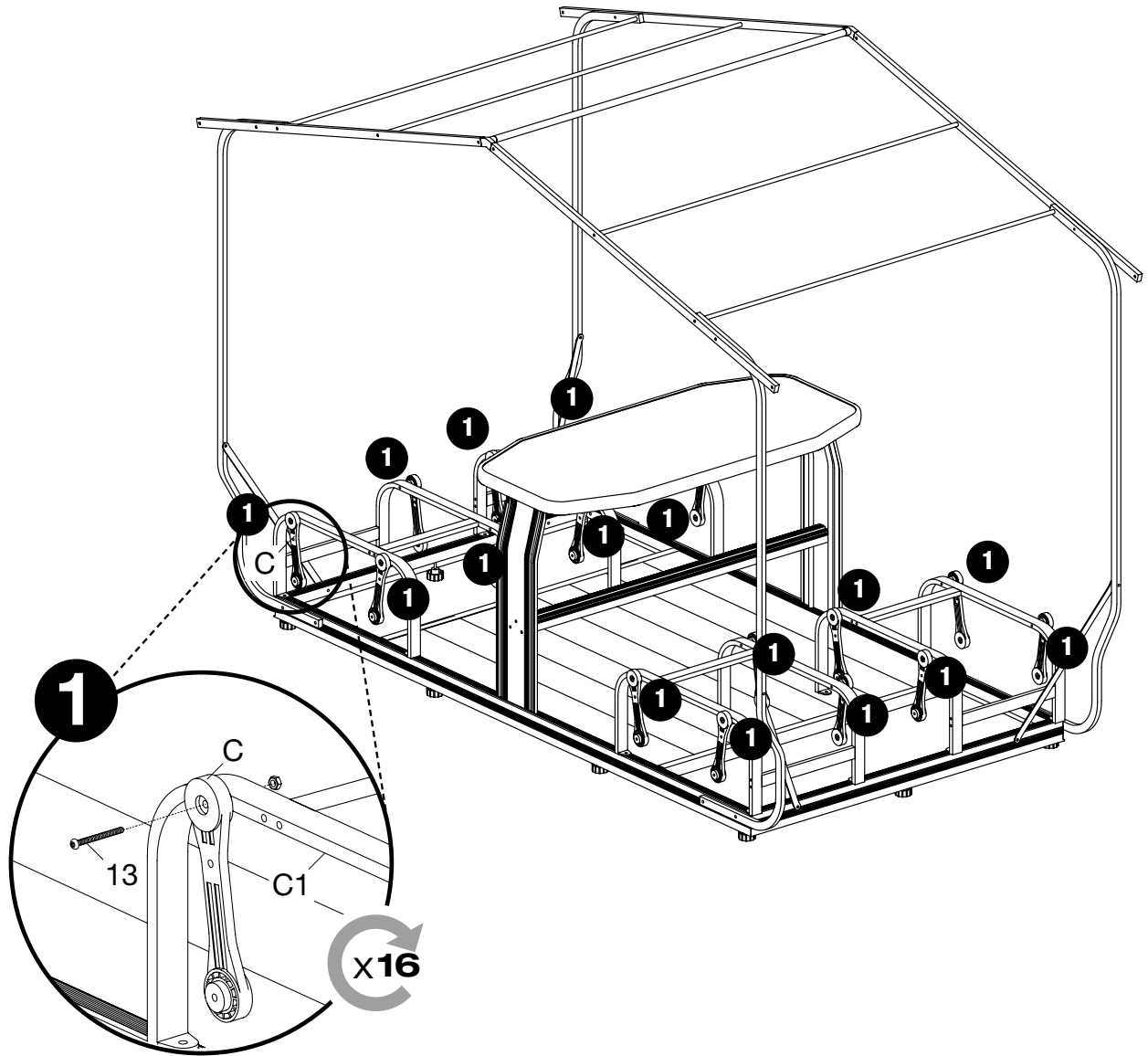

Cx16

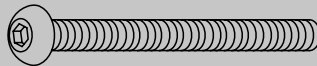

13x16



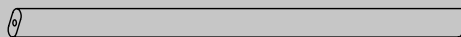
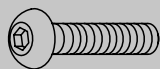
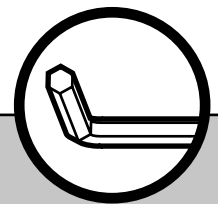
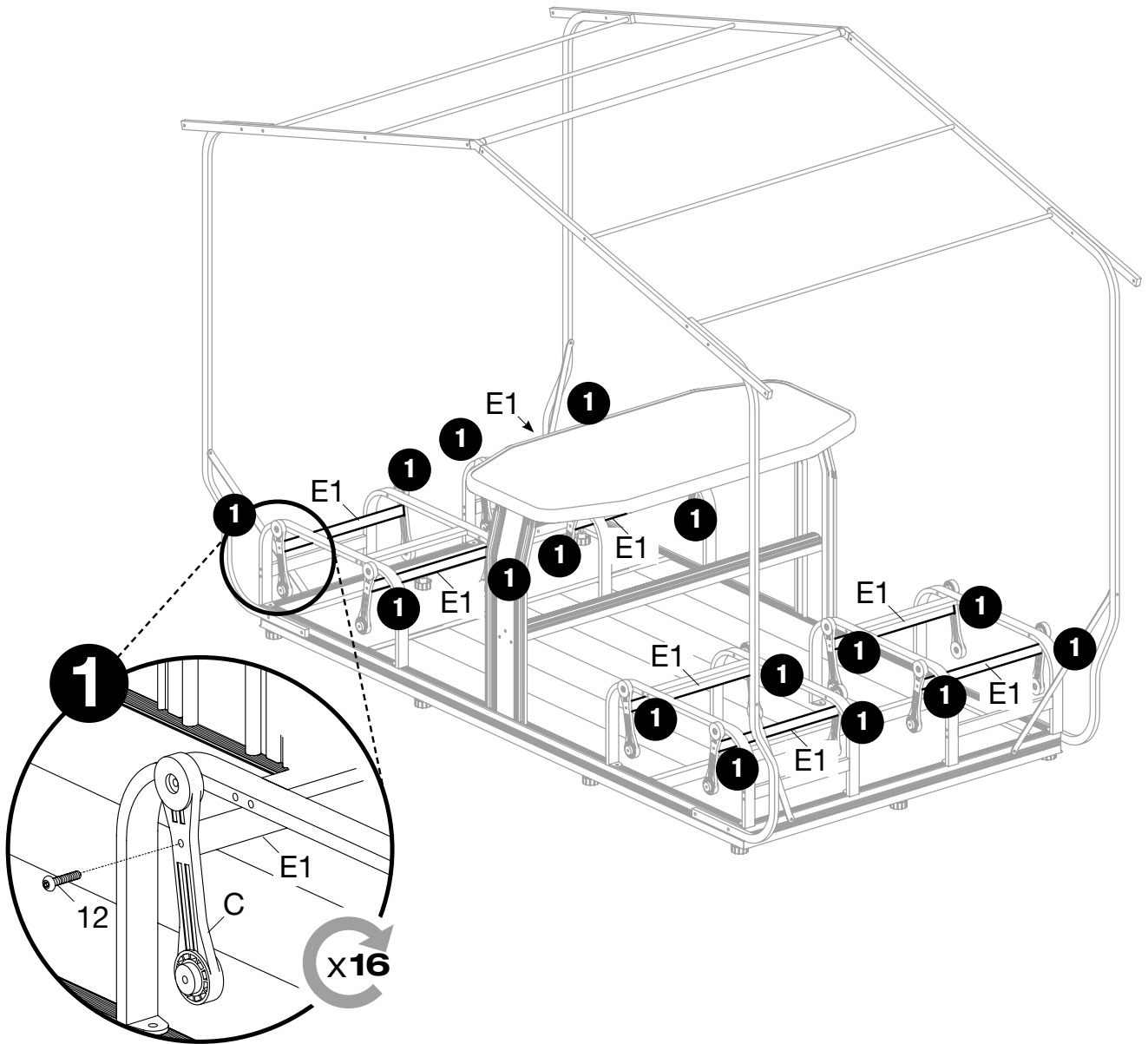

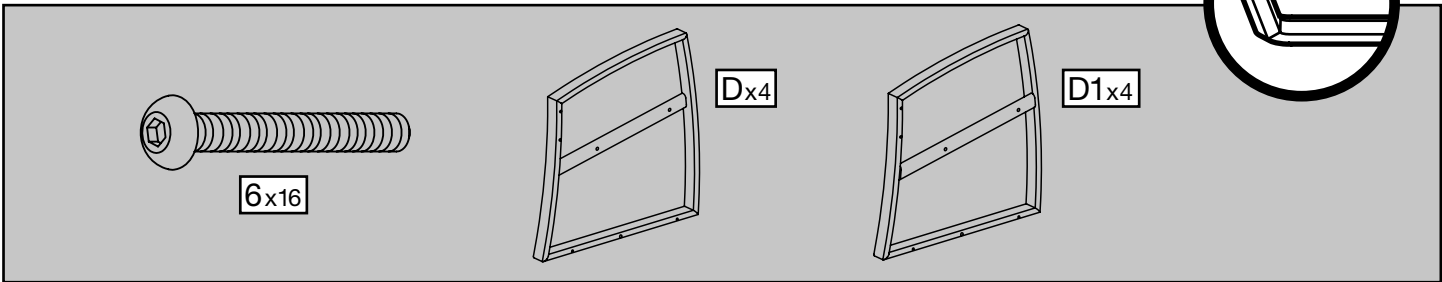
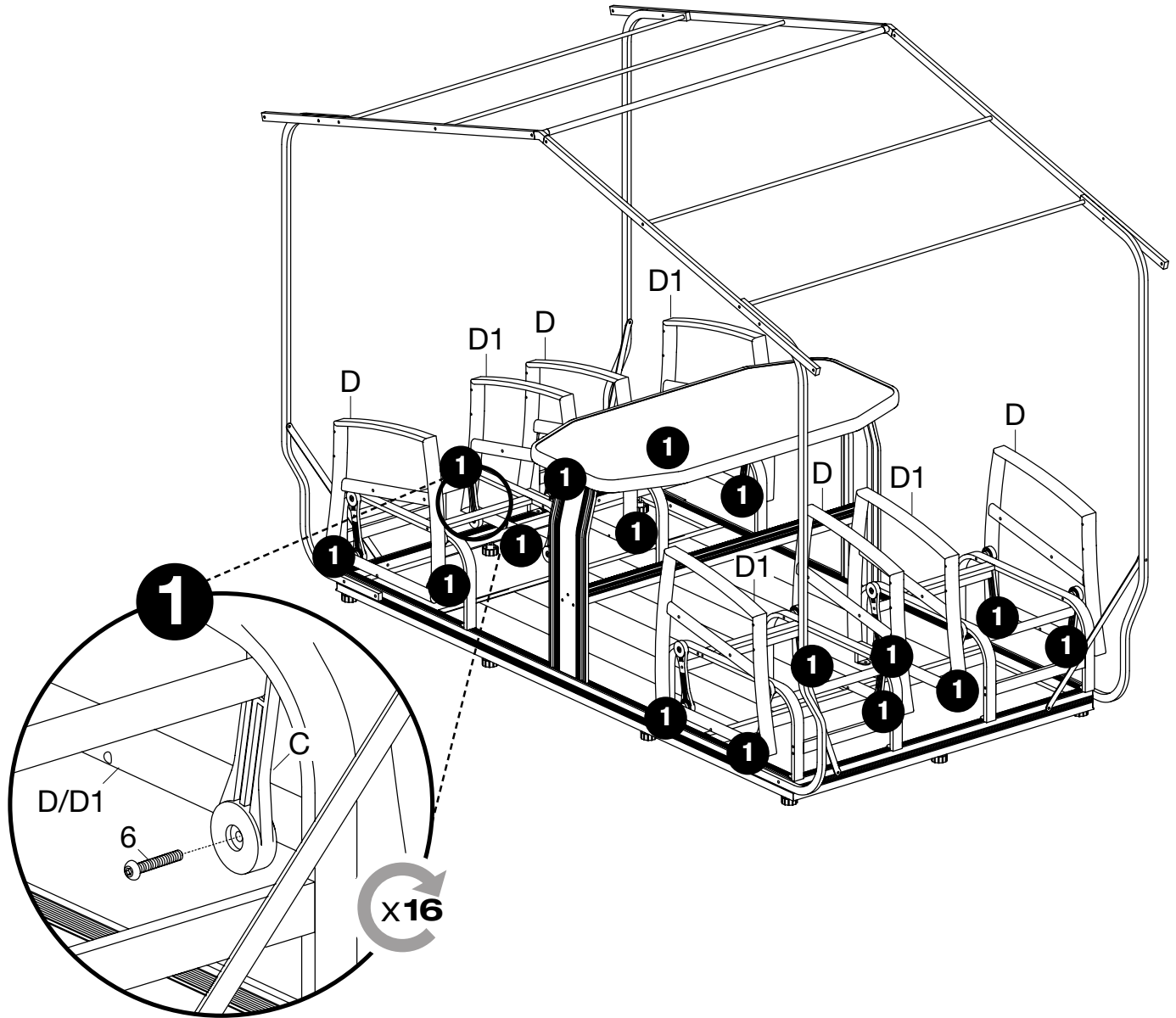

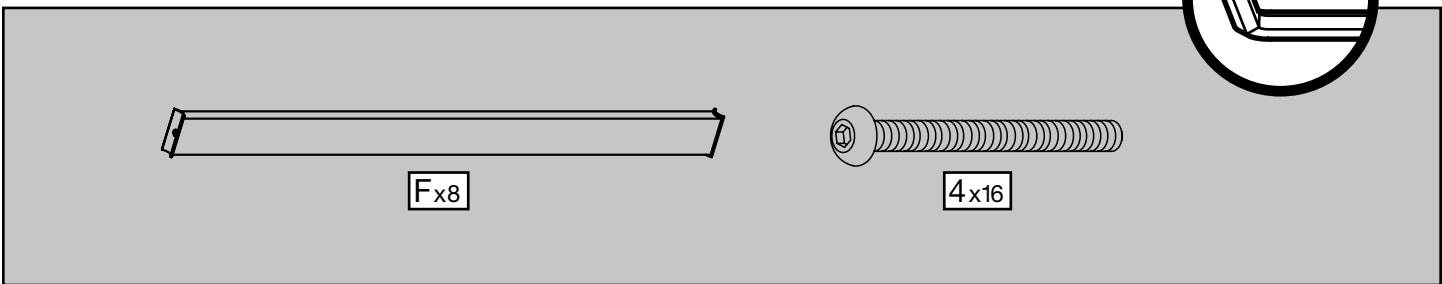
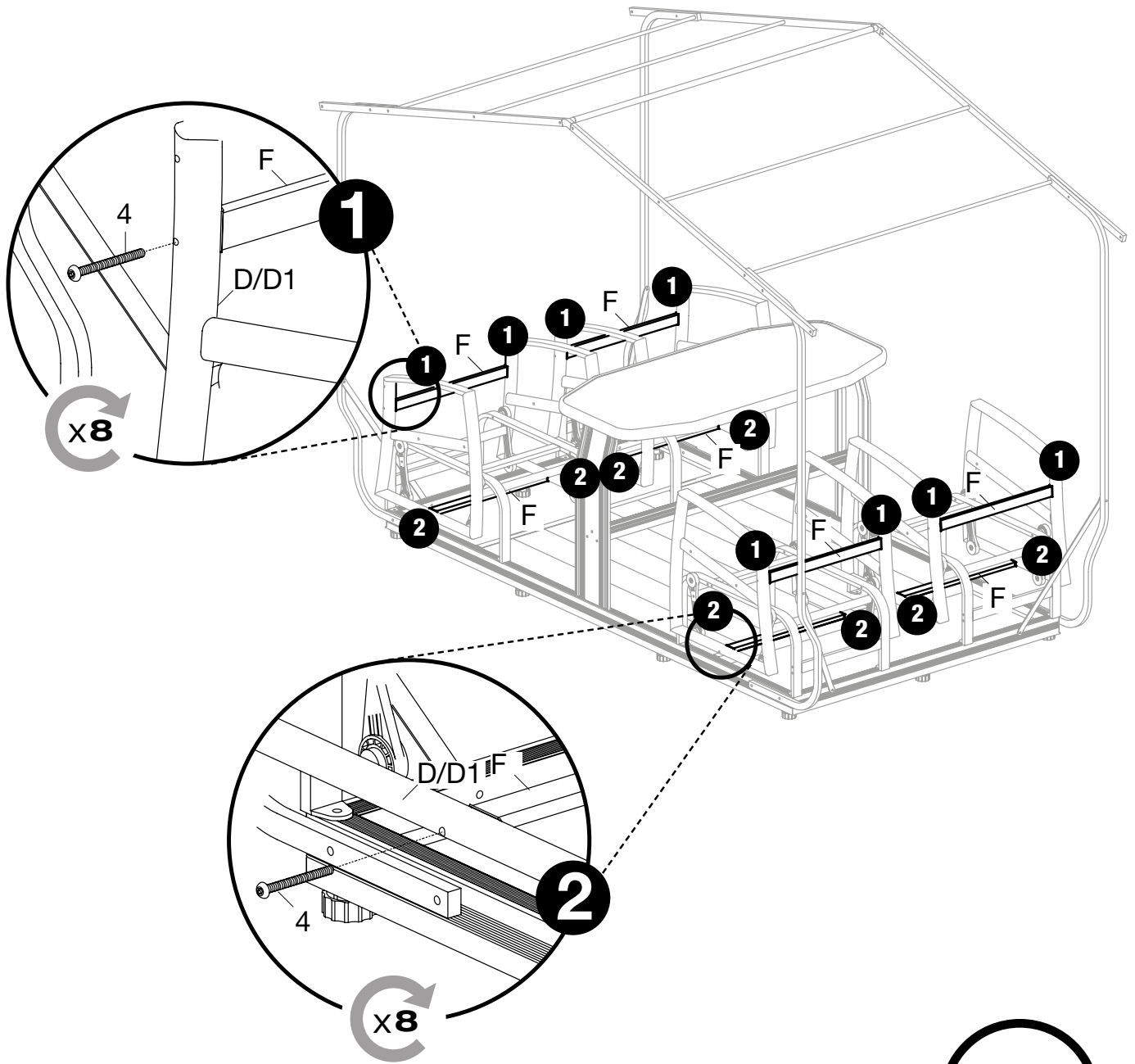

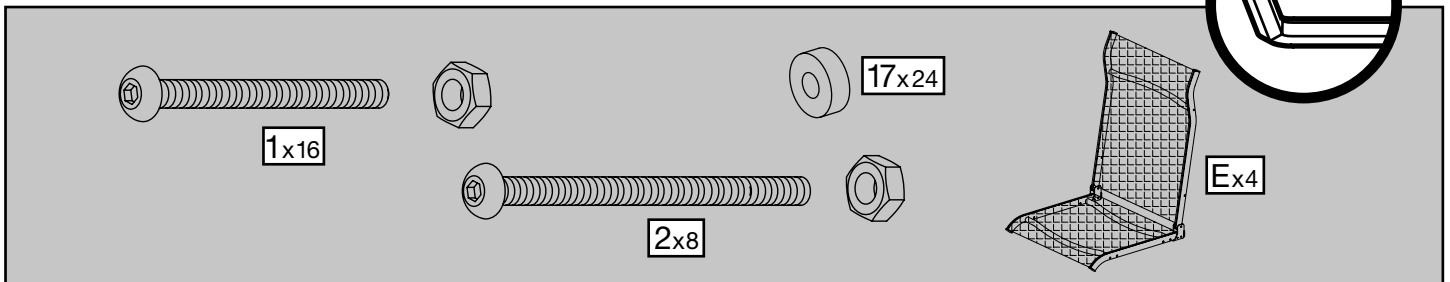
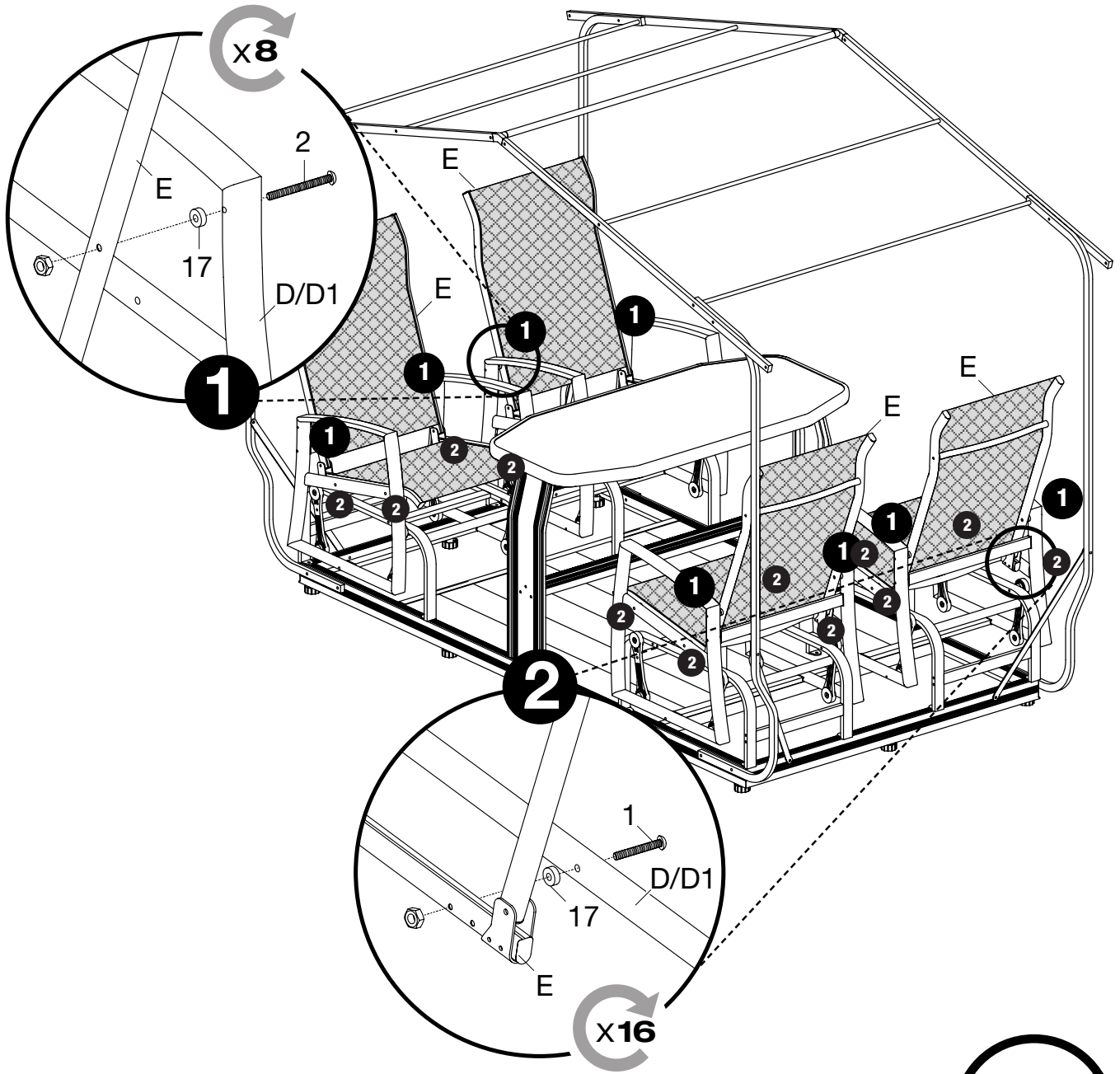

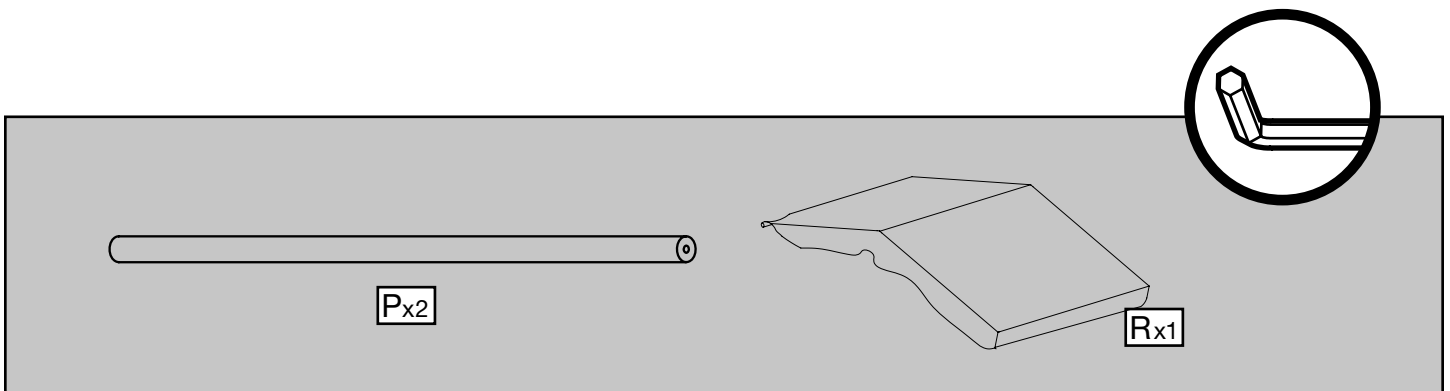
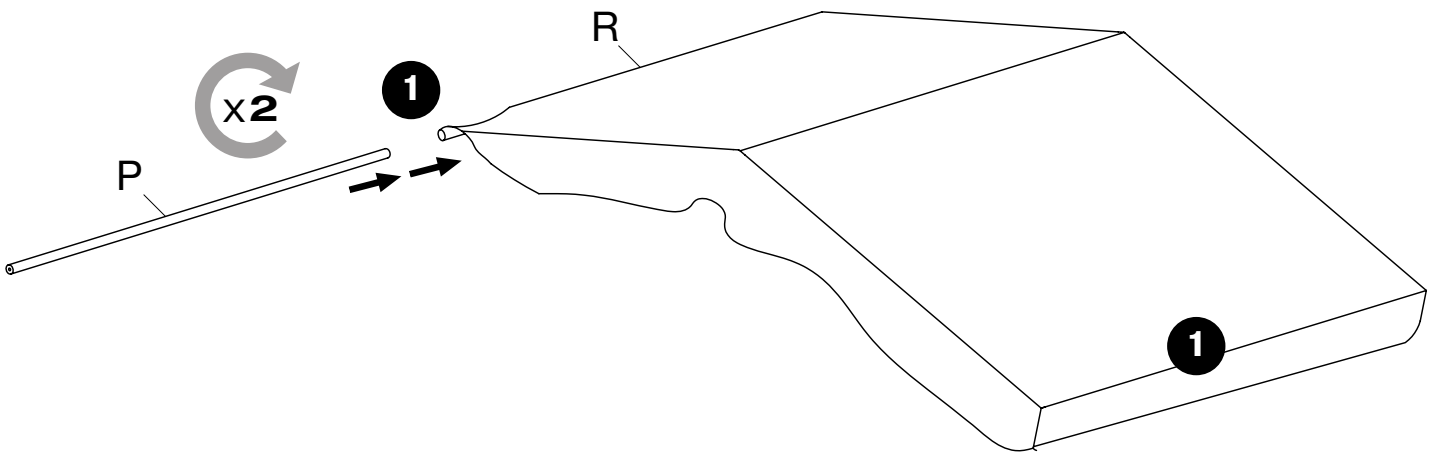

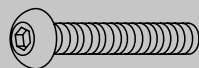
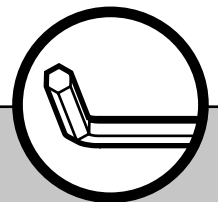
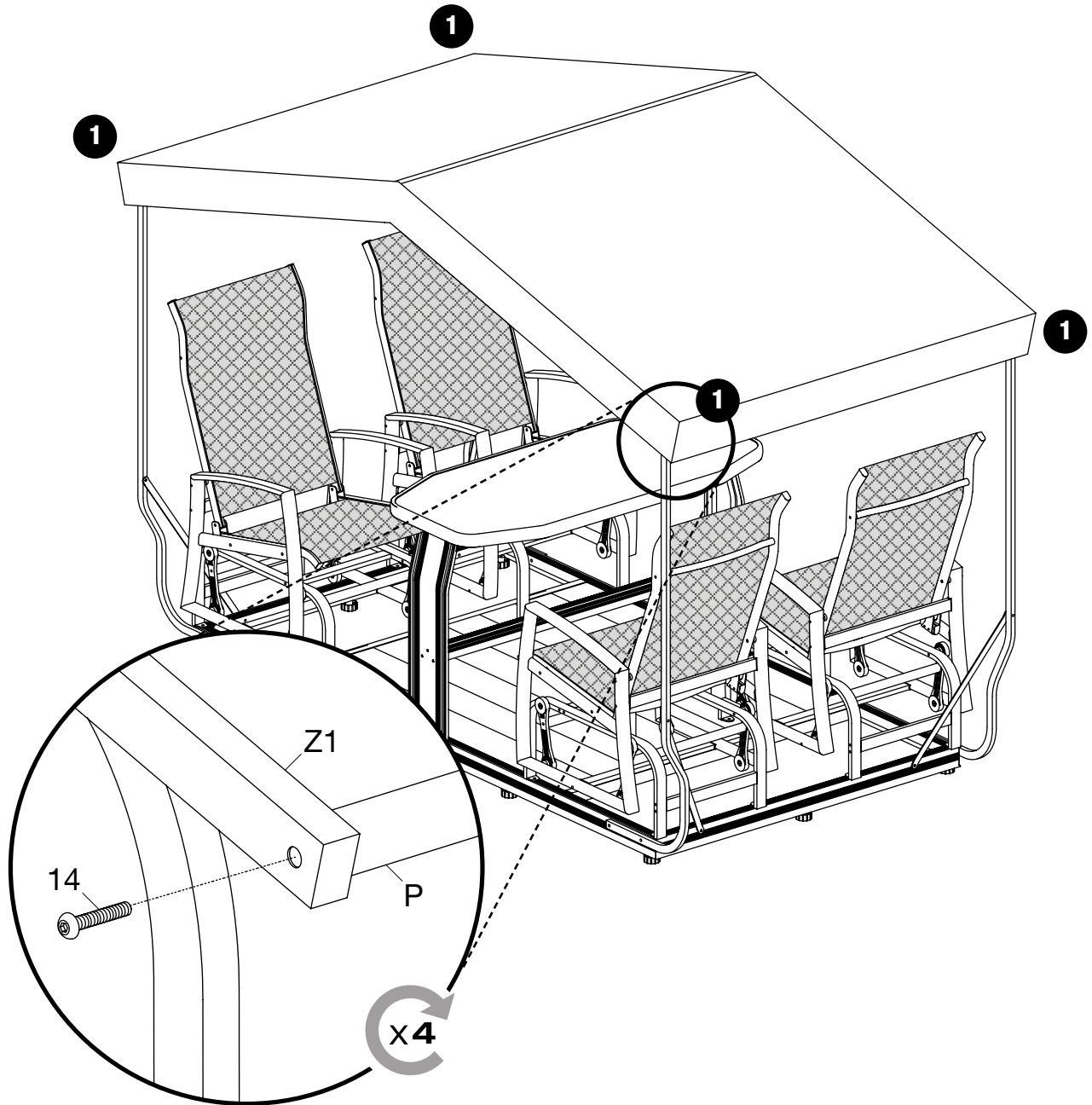

14x4

SOJAG ■ I
produits saisonniers • seasonal products