

**HEAVY DUTY FRONT BUMPER  
2010-18 DODGE RAM 2500-3500**

**PARTS LIST:**

1	Heavy Duty Front Bumper Assembly	8	12-1.75mm x 50mm Hex Bolts
2	Frame Mounting Brackets	24	12mm x 37mm OD x 3mm Flat Washers
4	12mm x 90mm Hex Bolts	12	12mm Nylon Lock Nuts
		2	License Plate Mounting Plugs

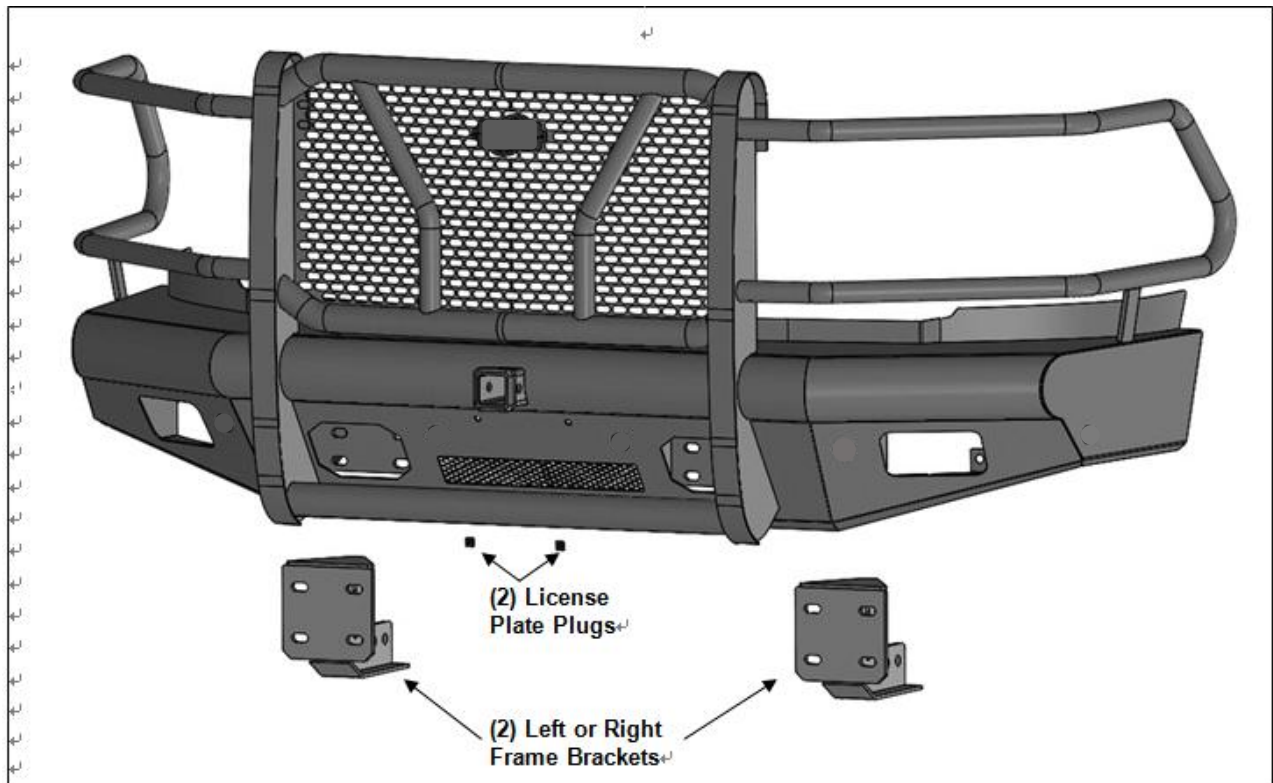

**PROCEDURE:**

- 1. REMOVE CONTENTS FROM BOX. VERIFY ALL PARTS ARE PRESENT. READ INSTRUCTIONS CAREFULLY BEFORE STARTING INSTALLATION. BUMPER IS HEAVY, ASSISTANCE IS HIGHLY RECOMMENDED. CUTTING MAY BE REQUIRED.**
2. Remove the license plate. On models with factory fog lights, unplug both lights and release the wiring harness from the back of the bumper, **(Figure 1)**. Move the wiring harnesses out of the way during bumper installation.
3. Open the front hood and temporarily remove the top plastic cover between the radiator and the grille. Next, remove the plastic radiator grille for easier access to top bumper bracket bolts, **(Figure 2)**. **NOTE:** Pay close attention to the type and location of all factory hardware for reinstallation. Move the grille and cover to a clean, stable work area.
4. Release the clips attaching the lower splash guard to the back of the front bumper, (if equipped). Locate the factory bumper bolts attaching the outer bumper to the inner brackets, **(Figure 3 & 4)**. With assistance, remove the bumper assembly, **(Figure 5)**. **WARNING!** Assistance is required to hold the bumper in place during hardware removal to prevent the bumper from falling. Slide the bumper assembly off of the tow hooks.

**HEAVY DUTY FRONT BUMPER  
2010-18 DODGE RAM 2500-3500**

5. Next, remove the (2) tow hooks. Remove the inner bumper brackets and lower frame extensions from the ends of the frame, **(Figures 5—7)**. **NOTE:** Lower frame extensions cannot be reinstalled.  
**IMPORTANT:** On some models equipped with turbo diesel, the intercooler and lower mounting bracket will need to be loosened or removed to remove the double bolt plate attaching the bumper bracket to the end of the frame. Assistance is recommended. **OPTION:** To remove the double bolt plates without removing the intercooler, use a hacksaw to cut the threaded ends off of the double bolt plates. Reinstall the intercooler and brackets, (if removed), once bolt plates and bumper brackets have been removed, **(Figures 6 & 7)**.
6. Select (1) Frame Bracket. Line up the holes in the Bracket with the outside of the frame. Reuse the factory double bolt plate to attach the Bracket to the outside of the frame. If the double bolt plate was cut use the provided (2) 12mm x 90mm Hex Bolts, (4) 12mm Flat Washers and (2) 12mm Nylon Lock Nuts. Reuse the factory bumper bracket hardware to attach the Bracket to the outside of the frame, **(Figures 8 & 9)**. **NOTE:** Insert bolts through Frame Bracket and out through the frame. Snug but do not fully tighten hardware at this time. Repeat this Step to install the Frame Bracket on the passenger side.
7. Carefully remove both fog lights from the back of the OE bumper, if equipped.  
**Models with fog lights:**
  - a. On models with factory fog lights, carefully snap each fog light into the (3) mounting tabs on the back of the Bumper, **(Figure 10)**.
  - b. Reattach the factory wiring harness to fog lights once Bumper has been installed.
8. With assistance, position the HD Bumper assembly up to the (2) Frame Brackets. **WARNING:** To avoid possible injury or damage to the vehicle, do not proceed until the Bumper is fully and safely supported. Attach the Bumper to the (2) Frame Brackets with (8) 12mm x 50mm Hex Bolts, (16) 12mm Flat Washers and (8) 12mm Nylon Lock Nuts, **(Figure 12)**. Snug but do not fully tighten hardware.
9. Select the (2) factory tow hooks. Reuse the factory tow hook hardware to attach the tow hooks to the mounting plates on the Front Bumper, **(Figure 13)**.
10. Level and adjust the Heavy Duty Bumper to the vehicle and tighten all hardware.
11. Reinstall the grille and top cover.
12. Install (2) Plastic License Plate Plugs into the holes in the Heavy Duty Bumper. Reuse factory screws to attach license plate to Plugs.
13. Use a sharp knife or hacksaw blade to cut off lower portion of fender liner to match Bumper profile as desired.
14. Do periodic inspections to the installation to make sure that all hardware is secure and tight.

**To protect your investment**, do not use any type of polish or wax that may contain abrasives that could damage the finish. Mild soap may be used to clean the Bumper Assembly.

Driver Side Installation Pictured

Remove factory fog lights (if equipped). Also release all wiring clips from bumper

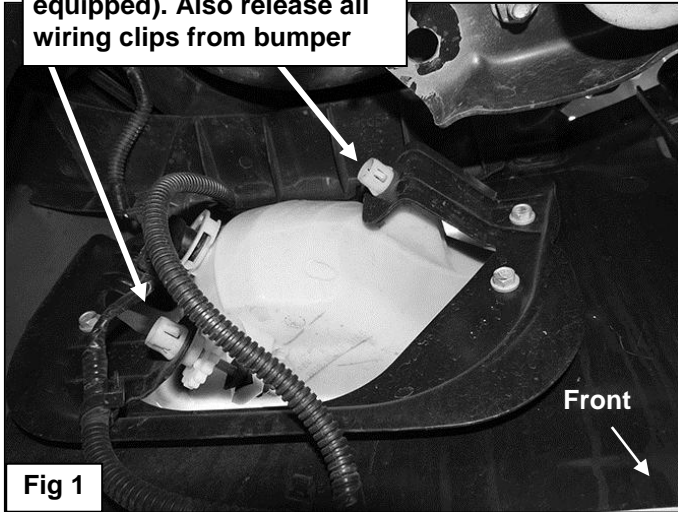
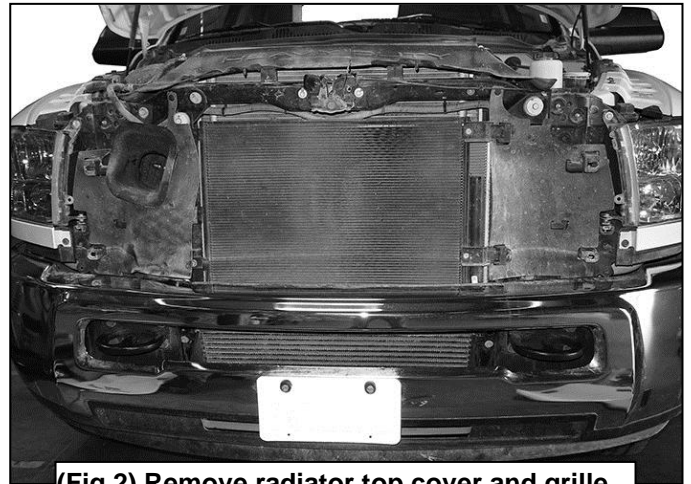

Fig 1



(Fig 2) Remove radiator top cover and grille



(Fig 3) Remove driver side top bumper hardware

Remove lower frame extension  
(pictured from below)

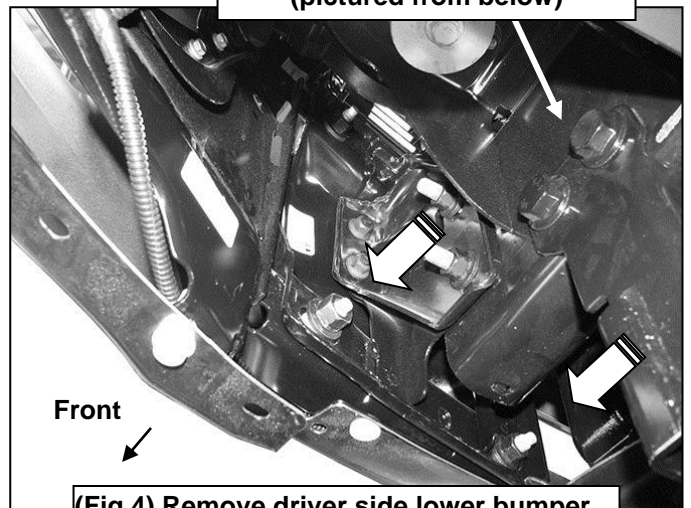

(Fig 4) Remove driver side lower bumper bracket hardware (pictured from below)

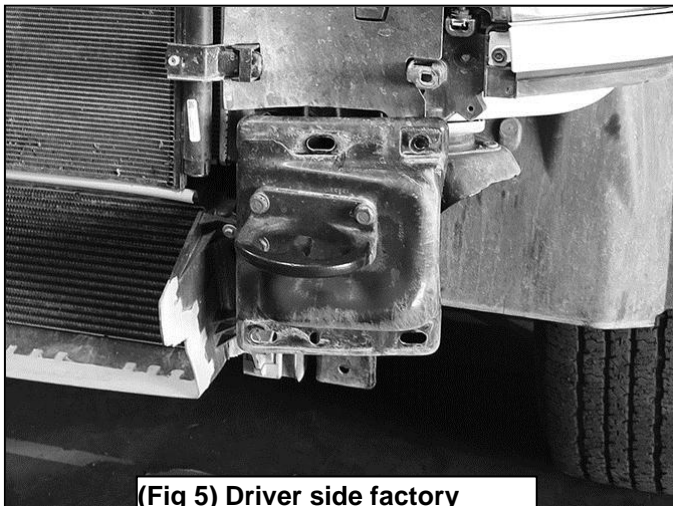

(Fig 5) Driver side factory bumper bracket and tow hook

Driver Side Installation Pictured

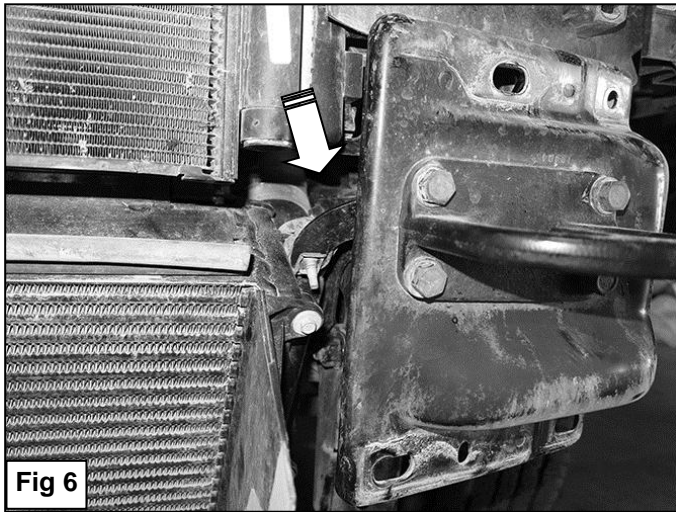

**Diesel models, loosen top support bracket hardware at frame and intercooler (large arrow). Temporarily remove lower hanging intercooler bracket from side of frame**

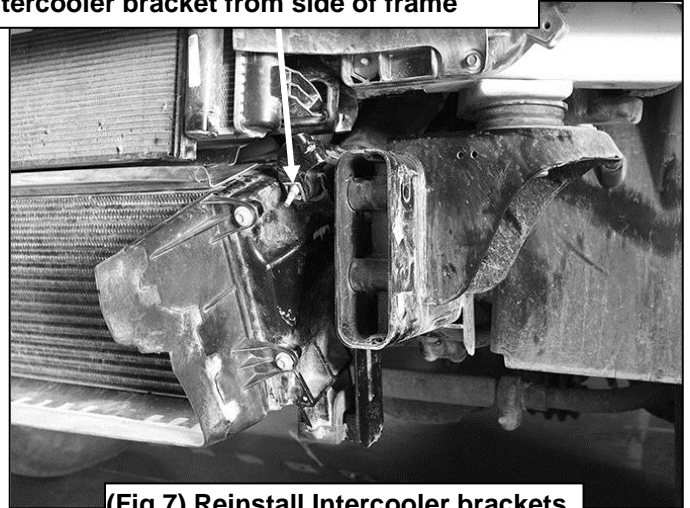

- (2) 12mm x 90mm Hex Bolts
- (4) 12mm Flat Washers
- (2) 12mm Nylon Lock Nuts

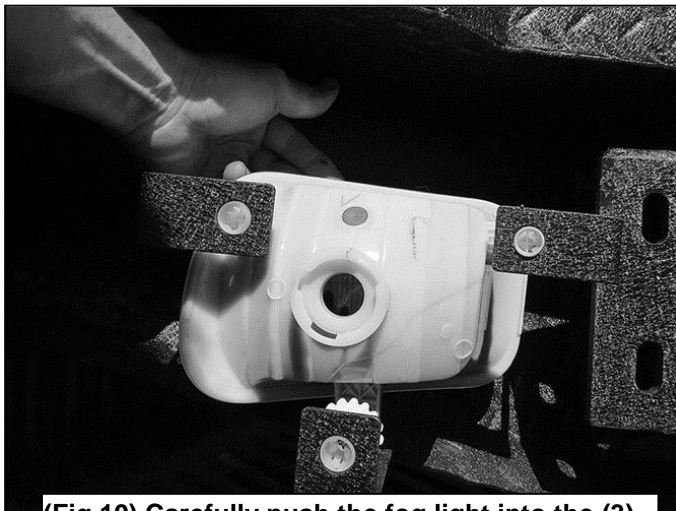
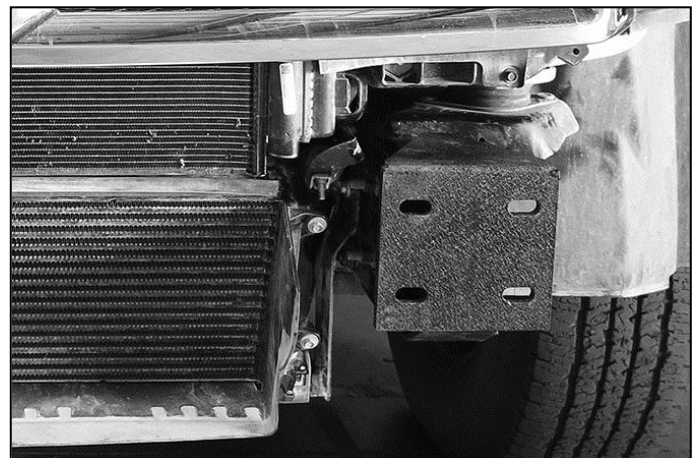
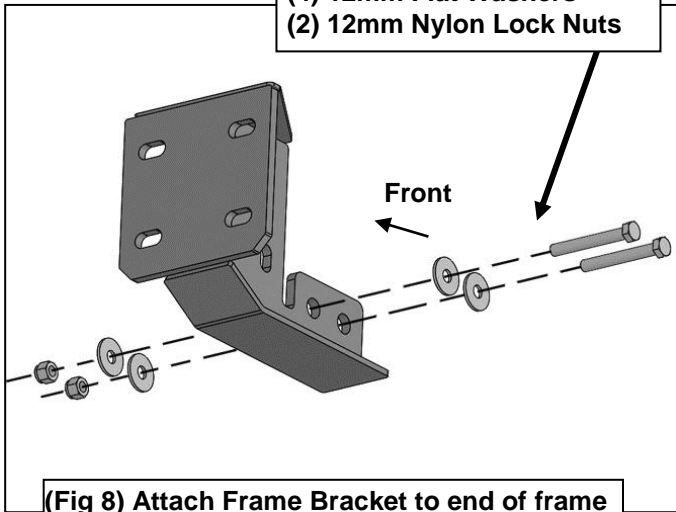

**HEAVY DUTY FRONT BUMPER  
2010-18 DODGE RAM 2500-3500**

**Driver Side Installation Pictured**

**Factory double bolt plate or  
(2) 12mm x 90mm Hex Bolts  
(4) 12mm Flat Washers  
(2) 12mm Nylon Lock Nuts**

**(4) 12mm x 50mm Hex Bolts  
(8) 12mm Flat Washers  
(4) 12mm Nylon Lock Nuts**

