

**STEELCRAFT EXTREME GRILLE GUARD
2015—2022 F-150**

PARTS LIST:

1	Grille Guard	4	12mm x 32mm x 3mm Flat Washers
1	Driver/left Frame Bracket	4	12mm Lock Washers
1	Passenger/right Frame Bracket	4	10-1.5mm x 30mm Hex Bolts
1	Driver/left "Short" Top Bracket (2015-17)	8	10mm x 24mm x 2.2mm Flat Washers
1	Passenger/right "Short" Top Bracket (2015-17)	4	10-1.5mm Nylon Locknuts
1	Driver/left "Tall" Top Bracket (2018-20)	2	8-1.25mm x 50mm Hex Bolts
1	Passenger/right "Tall" Top Bracket (2018-20)	2	8-1.25mm x 30mm Hex Bolts
1	Driver/left Top Bracket W-ID Hole (2021-On)	6	8mm x 22mm x 2mm Flat Washers
1	Passenger/right Top Bracket W-ID Hole (2021-On)	2	8mm Lock Washers
2	12-1.75mm Double Nut Plates	2	8-1.25mm Nylon Lock Nuts
4	12-1.75 x 35mm Hex Bolts	1	2.5mm Wrench

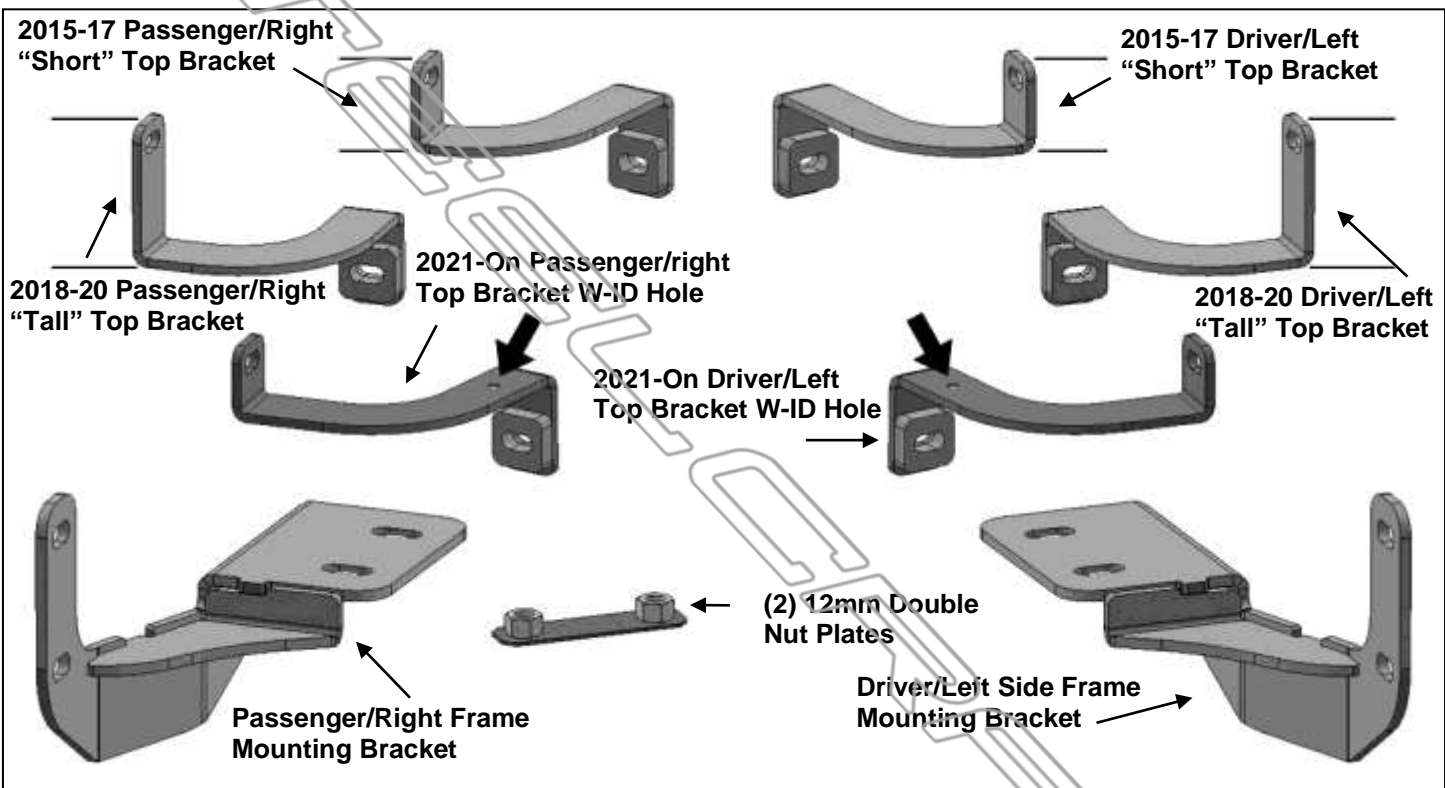

PROCEDURE:

REMOVE CONTENTS FROM BOX. VERIFY ALL PARTS ARE PRESENT. READ INSTRUCTIONS CAREFULLY BEFORE STARTING INSTALLATION. ASSISTANCE IS RECOMMENDED. CUTTING IS REQUIRED ON 2015-20 VEHICLES WITHOUT TOW HOOKS. NOTE: It may be necessary to remove/relocate the front license plate and license plate bracket on EcoBoost equipped models.

1. Remove the Top Brackets from bracket kit box. Separate and identify the Top Brackets, **(Figure 1)**.

IMPORTANT: The Top Brackets look similar but there are (3) different designs to fit model years.

2. Select the correct Top Bracket installation for your model year.

2015-17 and 2018-20 Models Top Bracket installation only:

- Disconnect any wire harness leading to the front bumper, (fog lights for example, see **Fig 12**).
- From behind the bumper, remove the hardware attaching the bottom of the bumper to the bumper brackets.
- Remove the plastic impact pads from the bumper, **(Figures 2 & 3)**.
- Through the opening in the front of the bumper, remove the factory hex nuts, **(Figures 2 & 3)**, and remove the bumper assembly, **(Figure 4)**. **IMPORTANT:** Assistance is required to hold the bumper in place as hardware is removed.

- e. Select the correct driver/left side Top Bracket, **(Figures 5 & 7)**. Remove the hex bolt from the top-center of the bumper bracket on the back of the bumper, **(Figures 6 & 8)**.
- f. Attach the Top Bracket to the back of the bumper bracket with the included (1) 8mm x 50mm Hex Bolt, (1) 8mm Lock Washer and (1) 8mm Flat washer, **(Figures 6, 8 & 9)**. With Bracket mounting plate straight up and down, fully tighten the Hex Bolt.
- g. Repeat **Steps e & f** to install the passenger/right side Top Bracket.
- h. Do not reinstall bumper at this time. **Skip to Step 3.**

2021-On Models Top Bracket Installation Only:

- a. From under the front bumper, remove the plastic active air dam from behind the front bumper if equipped, **(Figure 10)**. **NOTE:** Only remove the air dam, **(Figure 11)**.
- b. Disconnect wire harnesses leading to the front bumper, **(Figure 12)**.
- c. From behind the bumper, remove the (3) large factory hex nuts attaching the bumper to each bumper bracket, **(Figure 13)**. Move bumper to a clean, soft surface. **IMPORTANT:** Assistance is required to hold bumper in place as hardware is removed.
- d. Remove the hex bolt from the bumper support on the back of the bumper, **(Figure 14)**. Select the driver/left side Top Bracket, **(Figure 15)**. Slightly loosen but do not remove the outer bolt on the end of the support.
- e. Slide the Top Bracket between the support and the back of the bumper. Attach the Top Bracket to the support bracket and bumper with the included (1) 8mm x 50mm Hex Bolt, (1) 8mm Lock Washer and (1) 8mm Flat washer, **(Figure 15 & 16)**. With Bracket mounting plate straight up and down, fully tighten the Hex Bolt.
- f. Repeat **Steps d & e** to install the passenger/right side Top Bracket.
- g. Do not reinstall the bumper at this time.

3. Determine if the vehicle is equipped with tow hooks.

Models with tow hooks, remove tow hooks and the trim around tow hooks, **(Figure 17)**. Reuse the factory bolts to hold the nut plate in place in the frame, **(Figure 19)**. Reinstall the bumper
Models without tow hooks, place (1) 12mm Double Nut Plate into the end of the frame and over the holes in the bottom, **(Figures 17 & 18)**. Insert the included (2) 12mm x 35mm Hex Bolts, (2) 12mm Lock Washers and (2) 12mm Flat Washers up through the frame and into the Nut Plate to hold the Nut Plate in the correct position, **(Figure 19)**. Leave hardware loose at this time. Repeat for the passenger/right side Double Nut Plate installation.

- a. **2015-20 models without tow hooks**, remove the plastic splash guard from the bottom of the bumper, **(Figure 20)**. Reinstall front bumper.
- b. **2021-on models without tow hooks:** Remove the fill panels blocking the openings in the bottom of the bumper, **(Figure 21)**. Reinstall the front bumper.

4. Select the driver/left side Frame Mounting Bracket, (Figure 22).

Models with tow hooks:

- a. Insert the Bracket between the tow hook and the frame. Reattach the tow hook over the Bracket with the factory bolts. Leave hardware loose. Repeat to install passenger/right Bracket.

Models without tow hooks:

- a. Attach the Bracket to the bottom of the frame and Nut Plate with the included (2) 12mm x 35mm Hex Bolts, (2) 12mm Lock Washers and (2) 12mm Flat Washers, **(Figure 22)**
- b. Repeat previous Step for passenger/right side Frame Bracket installation.

2015-2020 Models without tow hooks only:

- a. Hold splash guard up against bottom of Brackets and in line with mounting points on bottom of bumper. Mark location of Brackets onto splash guard, **(Figure 23)**.
- b. Cut out slots to clear brackets. Cut as little as possible to clear brackets, **(Figure 23)**.
- c. Reattach the splash guard to the bumper. **NOTE:** It may be necessary to temporarily remove the Frame Brackets to reinstall the splash guard.

5. With assistance, place the Grille Guard up to the outside of the Brackets, **(Figure 24)**. Attach the Grille Guard to the Frame Brackets with (4) 10mm x 30mm Hex Bolts, (8) 10mm Flat Washers and (4) 10mm Nylon Lock Nuts, **(Figures 25—27)**. Snug but do not tighten hardware at this time.
6. Attach the Top Brackets to the Grille Guard with (2) 8mm x 30mm Hex Bolts, (4) 8mm Flat Washers, (2) 8mm Nylon Lock Nuts, **(Figures 25—27)**.

**STEELCRAFT EXTREME GRILLE GUARD
2015—2022 F-150**

7. Center the Grille Guard on the vehicle. Once properly adjusted, fully tighten all hardware.
8. On models with grille mounted factory camera, remove the center screen, **(Figure 28)**.
9. Do periodic inspections to the installation to make sure that all hardware is secure and tight.

To protect your investment, Do not use any type of polish or wax that may contain abrasives that could damage the finish. Mild soap may be used to clean the Grille Guard.

Driver/left Side Installation Pictured

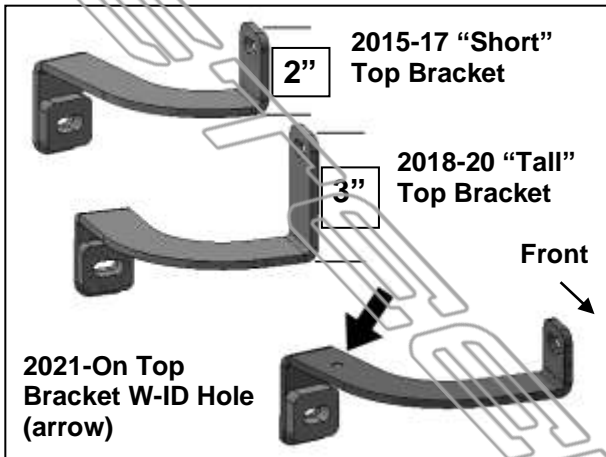

(Fig 1) Separate Top Brackets into pairs. Select the appropriate pair for your model year. Driver/left side illustrated above

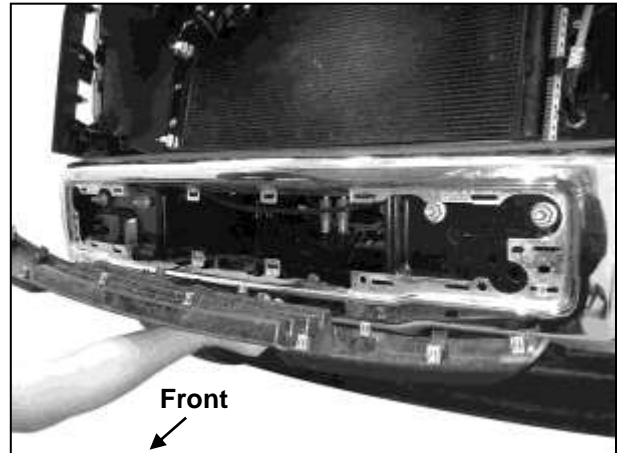

(Fig 2) 2015-17 models: From behind bumper, locate and remove bolts attaching bottom of bumper to bumper brackets. From front of bumper, remove bumper pad to locate and remove hex nuts and remove bumper. NOTE: Grille removed for instruction purposes only, do not remove grille



(Fig 3) 2018-20 models: From behind bumper, locate and remove bolts attaching bottom of bumper to bumper brackets. From front of bumper, remove bumper pad to locate and remove hex nuts and remove bumper.



(Fig 4) Remove bumper assembly. 2018-20 model pictured

Driver/left Side Installation Pictured

8mm x 50mm Hex Bolt
8mm Lock Washer
8mm Flat Washer

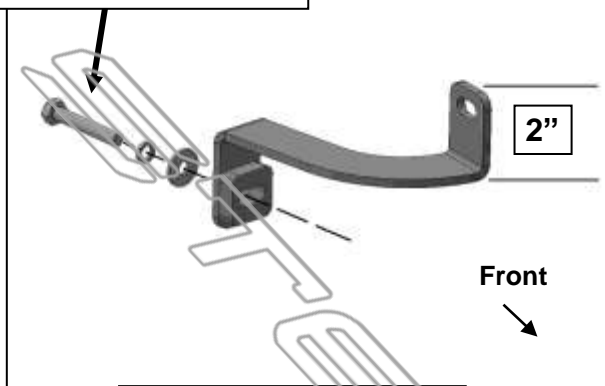

(Fig 5) 2015-17 Driver/left
"Short" Top Bracket

8mm x 50mm Hex Bolt
8mm Lock Washer
8mm Flat Washer

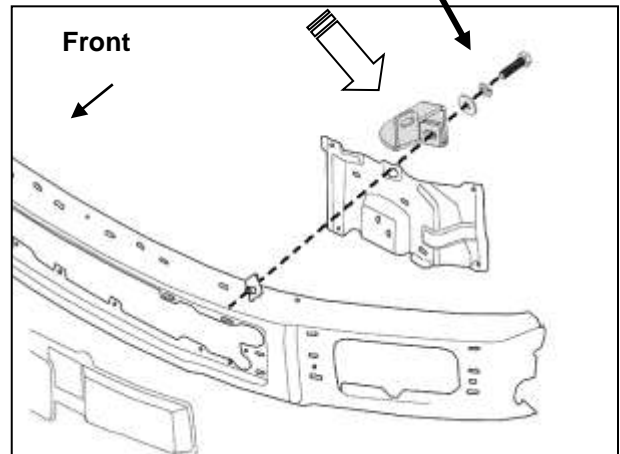

(Fig 6) Attach the driver/left Top Bracket to the back of the middle mounting hole on the top of the bumper bracket, (example of 2015-17 model illustrated)

8mm x 50mm Hex Bolt
8mm Lock Washer
8mm Flat Washer

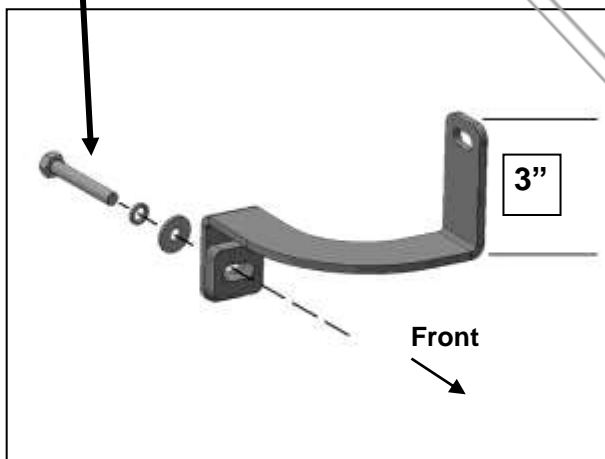

(Fig 7) 2018-20 models: Driver/left
"Tall" Top Bracket

8mm x 50mm Hex Bolt
8mm Lock Washer
8mm Flat Washer

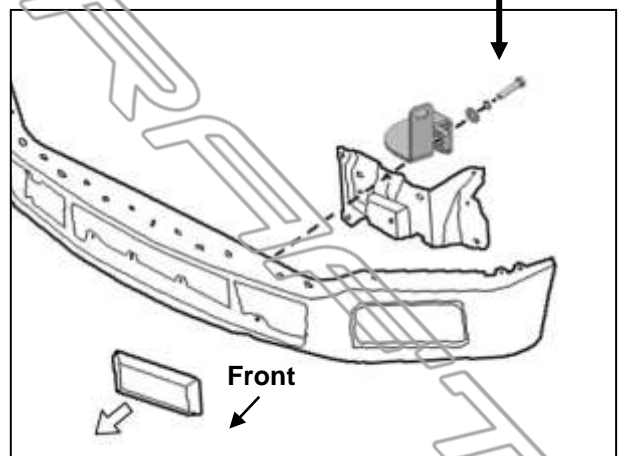

(Fig 8) Attach the driver/left side Top Bracket to the back of the middle mounting hole on the top of the bumper bracket (example of 2018-20 model illustrated)

Driver/left Side Installation Pictured



(Fig 9) 2018-20 models: Attach Top Support Bracket to back of bumper bracket

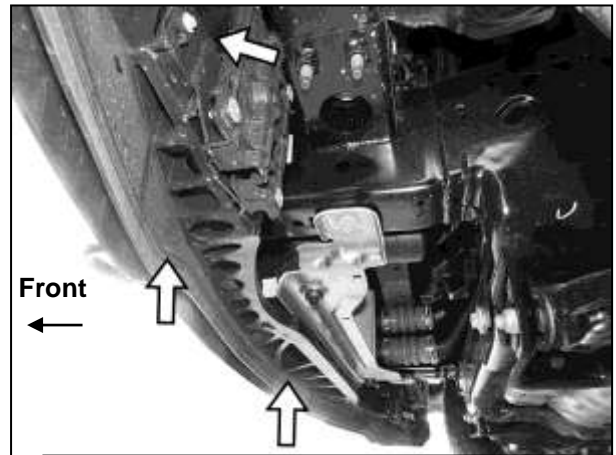

(Fig 10) 2021-On models, remove active air dam from back of bumper (arrows)



(Fig 11) Active air dam removed



(Fig 12) Unplug all wiring harnesses leading to the front bumper (arrow). 2021-On model pictured

Driver/left Side Installation Pictured

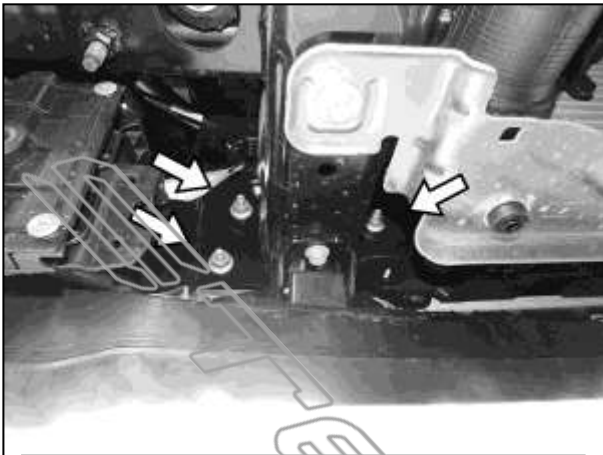

(Fig 13) 2021-On models, remove hex nuts from back of driver/left bumper bracket to remove bumper (arrows)

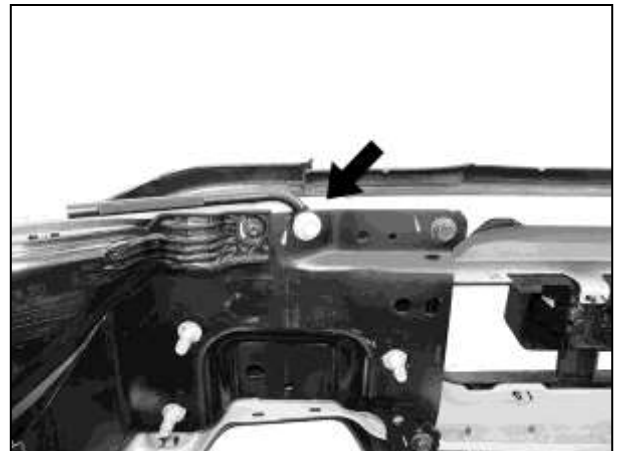

(Fig 14) 2021-On model, remove inner hex bolt from support bracket on the back of driver/left bumper bracket, (arrow). Loosen but do not remove outer hex bolt attaching support bracket

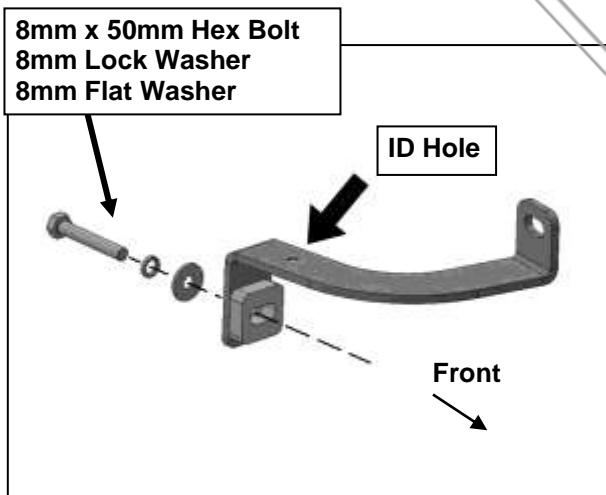

8mm x 50mm Hex Bolt
8mm Lock Washer
8mm Flat Washer

ID Hole

Front

(Fig 15) 2021-On models: Driver/left Top Bracket, note hole in Bracket for identification purposes only

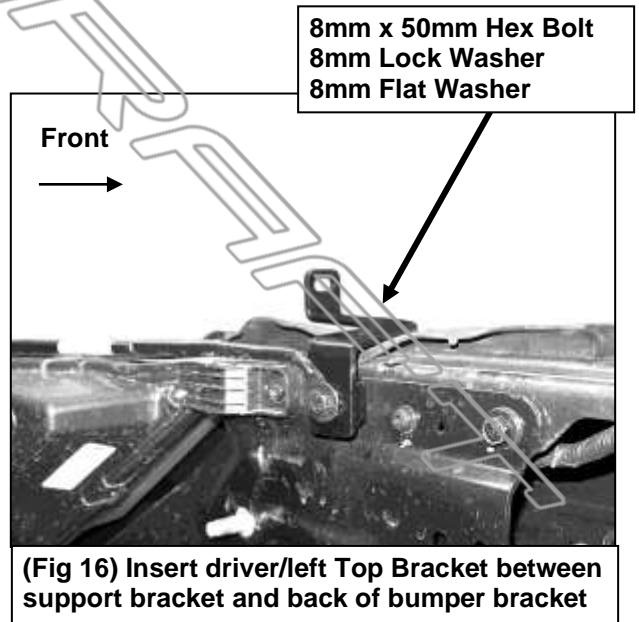

8mm x 50mm Hex Bolt
8mm Lock Washer
8mm Flat Washer

Front

(Fig 16) Insert driver/left Top Bracket between support bracket and back of bumper bracket

Driver/left Side Installation Pictured

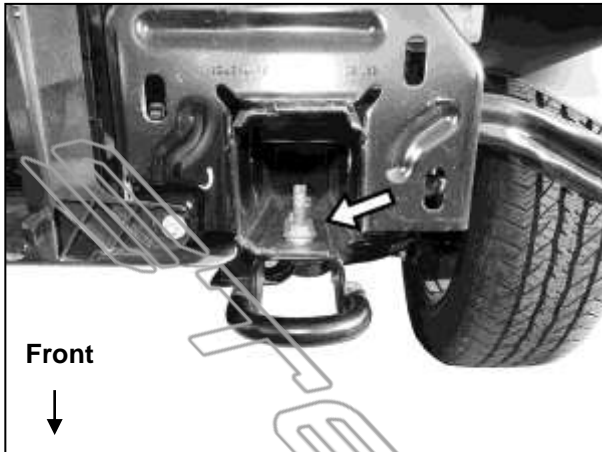

Front
↓

(Fig 17) Temporarily remove tow hooks if equipped. Models without tow hooks, insert Double Nut Plate (Fig 18) into end of frame

12mm x 35mm Hex Bolt
12mm Lock Washer
12mm Flat Washer



(Fig 18) Models without tow hooks, insert Double Nut Plates into end of frame (see Fig 17)



Front
→

(Fig 19) Use 12mm Hex Bolts to line up and hold the Nut Plate in place



(Fig 20) 2015-20 Model without tow hooks, remove splash guard from bottom of bumper

Driver/left Side Installation Pictured

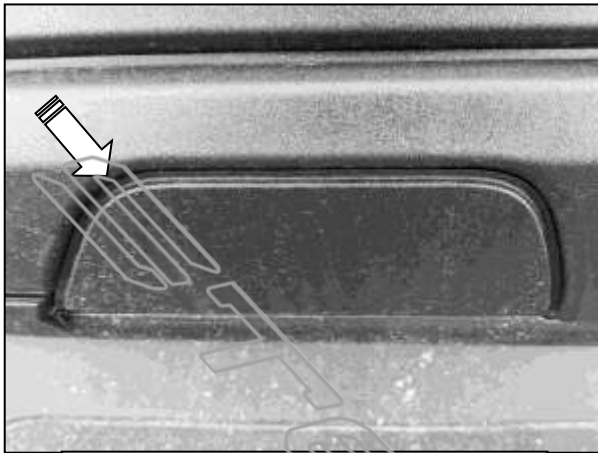

(Fig 21) On 2021-on models without tow hooks, remove plastic covers from bottom of bumper

Models without tow hooks, use:
(2) 12mm x 35mm Hex Bolts
(2) 12mm Lock Washers
(2) 12mm Flat Washers

12mm Double Nut Plate

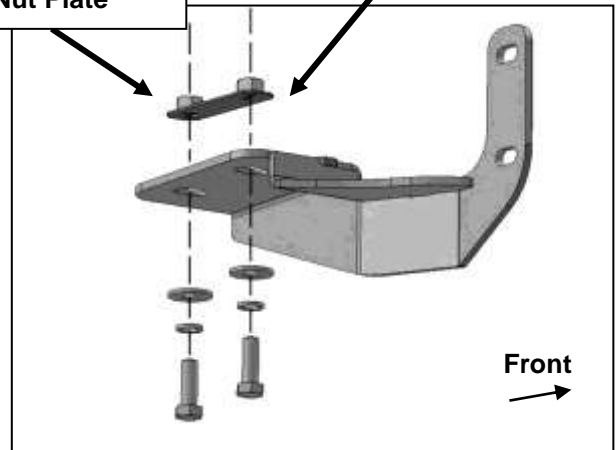

(Fig 22) Attach Frame Bracket to bottom of frame and Nut Plate. Models with tow hooks, install Frame Bracket between tow hook and frame

Do not cut through front or back edge of splash guard

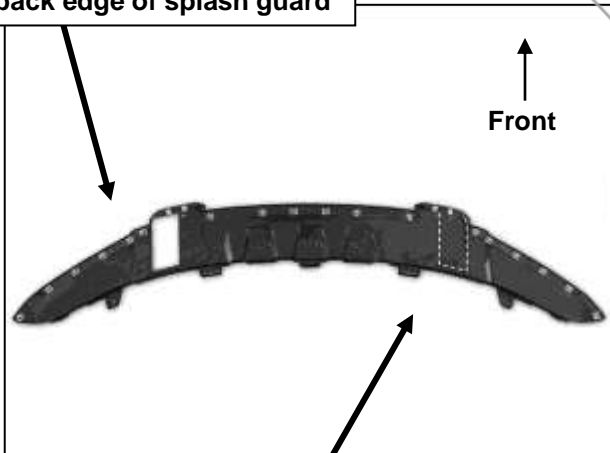

(Fig 23) 15-20 models: Hold the splash guard up to the bottom of Frame Brackets. Trace location of Brackets onto back of the plastic cover (dashed line). Cut as required to clear brackets

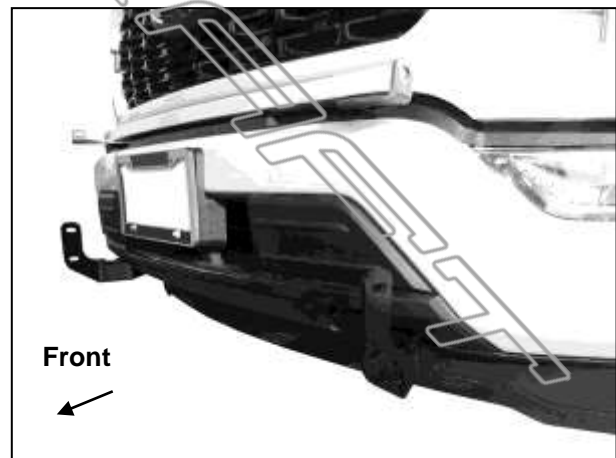

(Fig 24) Brackets installed (2021 model pictured)

Driver Side Installation Pictured

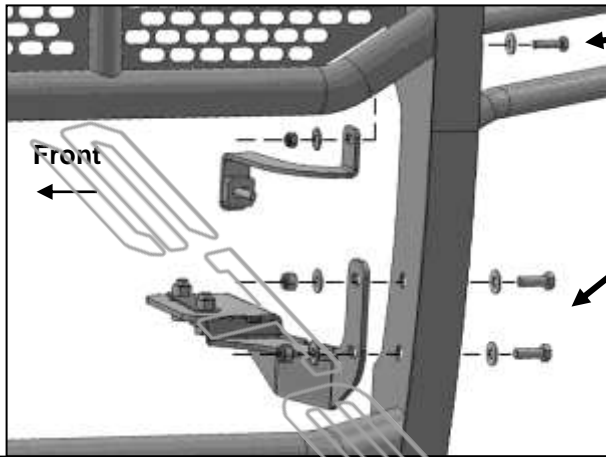

8mm x 30mm Hex Bolt
(2) 8mm Flat Washers
8mm Nylon Lock Nut

(2) 10mm x 30mm Hex Bolts
(4) 10mm Flat Washers
(2) 10mm Nylon Lock Nuts

8mm x 30mm Hex Bolt
(2) 8mm Flat Washers
8mm Nylon Lock Nut

(Fig 25) 2015-17 models: Complete installation

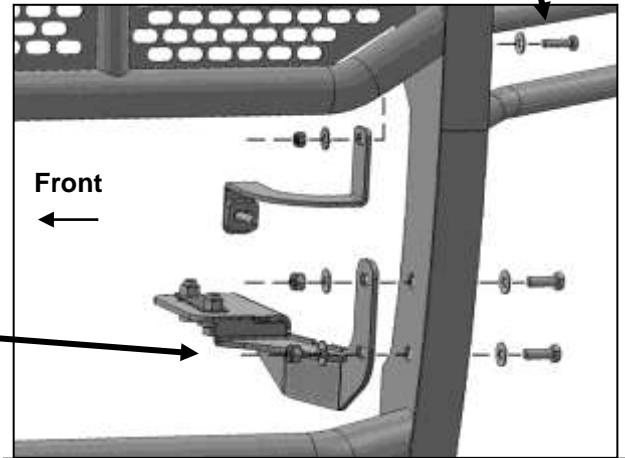

(2) 10mm x 30mm Hex Bolts
(4) 10mm Flat Washers
(2) 10mm Nylon Lock Nuts

(Fig 26) 2018-20 models: Complete installation

8mm x 30mm Hex Bolt
(2) 8mm Flat Washers
8mm Nylon Lock Nut

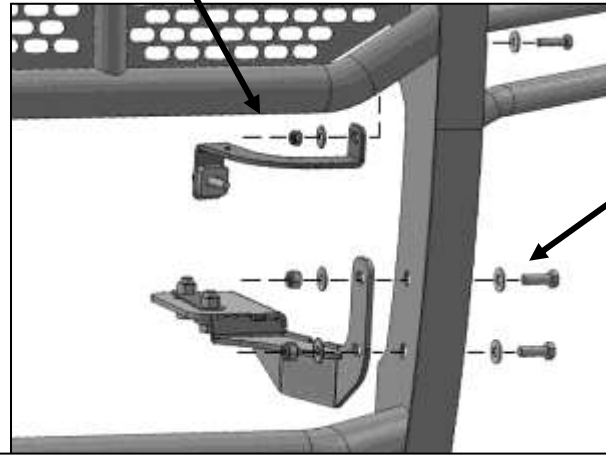

(2) 10mm x 30mm Hex Bolts
(4) 10mm Flat Washers
(2) 10mm Nylon Lock Nuts

(Fig 27) 2021-On models: Complete installation

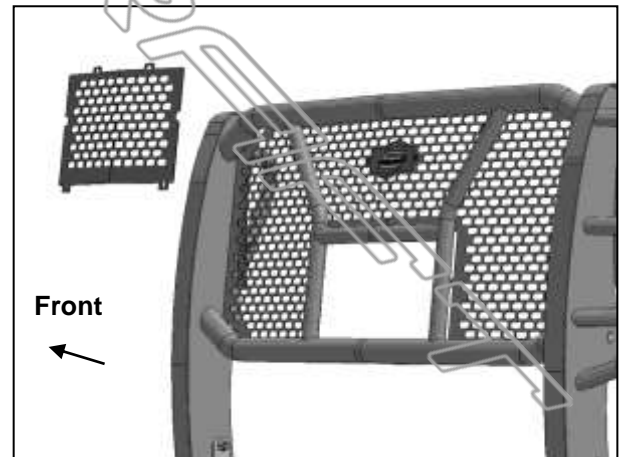

(Fig 28) On models equipped with grille mounted camera, remove center screen