

SAN-385
Sani-T Compact
Air Purifier



**PLEASE READ INSTRUCTIONS BEFORE USING
AND SAVE FOR FUTURE REFERENCE**

PRODUCT SPECIFICATIONS

Model No.	SAN-385
Power Rating	30 W
Voltage Rating	24 V DC
Noise (Max)	53 dB(A)
CADR (Clean Air Delivery Rate)	114 CFM (Cubic Feet/Minute)
Room Size	230-260 Sq. Ft.
Sensors	1 x Infrared Sensor
Display Indicators	5 x Touch Buttons for Functions (Fan Speed, On/Off/Auto, Light Mode, Filter, Timer), 1 x Air Quality Indicator Color Ring
Features	Touch Glass Control Panel
Product Size	8.66" Dia x 13.78" H
Net Weight	4.51 lbs. (6.38 lbs with Adapter)

WARNING !!!

TO REDUCE RISK OF FIRE, ELECTRIC SHOCK OR INJURY:

- Inspect the unit prior to use. Check power cord to ensure there is no damage to insulation. If the unit shows any signs of being dropped or damaged, do not plug in and contact the manufacturer.
- Always disconnect the power cord from electrical outlet before performing any maintenance or replacing the filter.
- Never operate the unit without the filter installed.
- Designed for indoor use only. Do not attempt to use outdoors.
- Do not use the unit near water, on wet surfaces or in high humidity environment. It should not be placed in/near a bathroom, shower, sauna, or swimming pool
- Do not use the unit near heated surfaces. Keep power cord away from heated surfaces.
- Place on flat stable surface. Keep unit upright at all times. Do not attempt to use if the unit is not in upright position.
- Never touch any part of the appliance or plug/unplug the power cord with wet hands.
- Never carry the unit by the power cord. Pick the unit up and carry by the base to move it.
- Plug the power cord directly into electrical outlet. Do not use extension cord as a power overload may cause over heating and risk of fire.
- Do not place the power cord under other appliances.
- This appliance is not intended for use by persons (including children) with reduced physical, sensory or mental capabilities, or lack of experience and knowledge, unless they have been given supervision or instruction concerning use of the appliance by a person responsible for their safety. Children should be supervised to ensure that they do not play with the appliance
- To avoid overheating, do not cover the appliance.
- If the power cord is damaged, it must be replaced or repaired by the manufacturer. Do not attempt to replace or repair the power cord.
- To reduce the risk of fire, keep textiles, curtains, or any other flammable material a minimum distance of 3 feet from the air outlet.
- Keep the appliance away from flammable liquids and vapors.
- If there is a loose fit between the power cord plug and the electrical outlet or the plug becomes very hot, the electrical outlet may need to be replaced. Check with a qualified electrician to replace the electrical outlet.

PRODUCT OVERVIEW

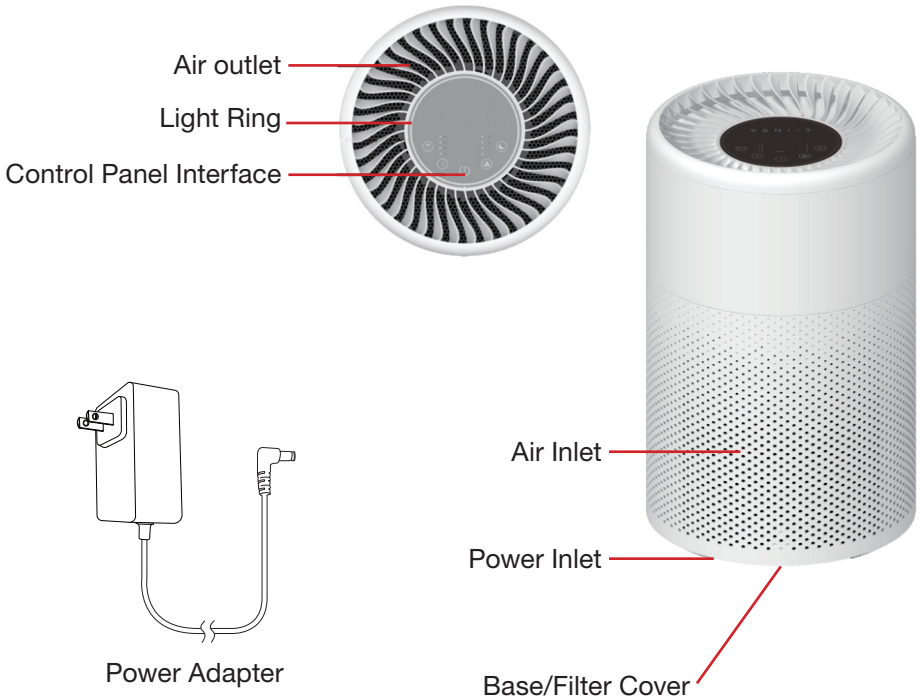

The SAN-385 Compact Air Purifier uses an infrared sensor to monitor the air quality in the surrounding area.

Based on the reading by the infrared sensor, the SAN-385 will illuminate the Air Quality Indicator Light to the color specific to the air quality.

The below chart shows the range of values for each color shown in the Air Quality Ring:

RING COLOR:	GREEN	YELLOW	RED
Air Quality =	GOOD < 50 AQI	ACCEPTABLE 50 – 100 AQI	POOR > 100 AQI

LOCATION & SET UP

Place the unit upright on a dry, flat surface indoors. Do not place too close to walls as this may affect the sensors and reduce the performance of the unit. We recommend keeping the unit a minimum of 8" away from walls.

Do not use in high humidity areas of the home such as bathrooms etc.

Do not cover or block the vents. The Air Intake holes on the base pull air into the unit. The vent blades on top of the unit expel purified air. Blocking the air flow in any direction will cause performance issues and/or over heating.

Connect the Power Adapter into the power outlet on the bottom of the unit. Plug power cord into electrical outlet.

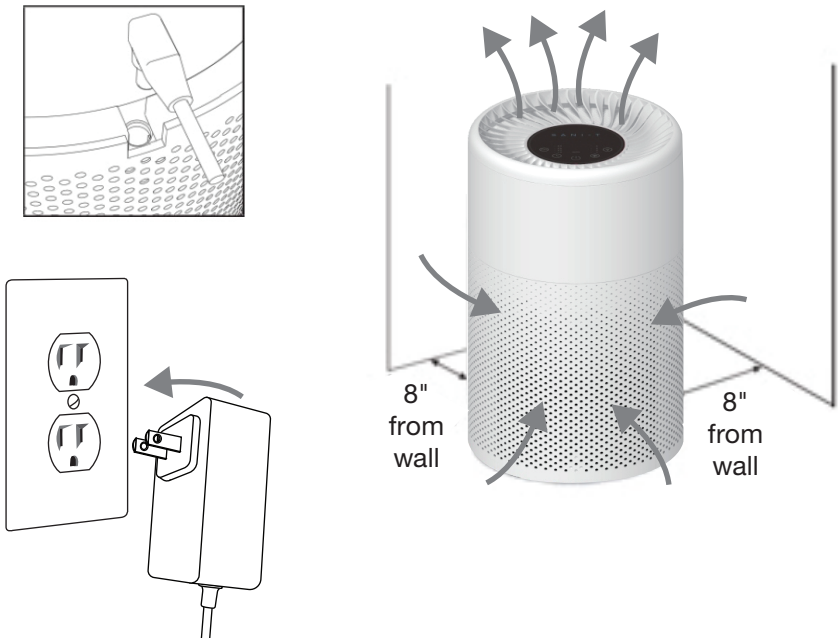

FIRST USE

When you plug the unit into the electrical outlet, it will beep once to alert you that it is receiving power.

Press the Power button  and the unit will beep again confirming it is now turned on; the Control Panel will illuminate.

Once turned on the infrared sensor will analyze the surrounding air. When analyzing, the display may cycle through the colors on the Air Quality Ring. Within approx. 20 seconds, the unit will complete the analysis and display the air quality sensed on the Air Quality Ring.

If you do not press any buttons after turning the unit on, it will begin operating in AUTO mode.

In most instances, leaving the unit in AUTO mode will be sufficient for daily use. Our goal is to make it simple for you set it and forget it so you can enjoy life and let the SAN-385 run in the background as needed.

In AUTO Mode, the fan speed will adjust itself based on the air quality:

- If the air quality is good, the Air Quality Ring will be GREEN and the fan will run intermittently on low speeds as required.
- If the air quality is acceptable with a low amount of pollutant, the Air Quality Ring will be YELLOW and the fan will run continuously on medium speeds until the air improves.
- If the air quality is poor with a high amount of pollutants, the Air Quality Ring will be RED and the fan will run continuously on high speeds until the air improves.
- As the Air Quality improves, the color of the display ring will change from RED to YELLOW to GREEN and adjust the fan speed accordingly.

THE CONTROL PANEL

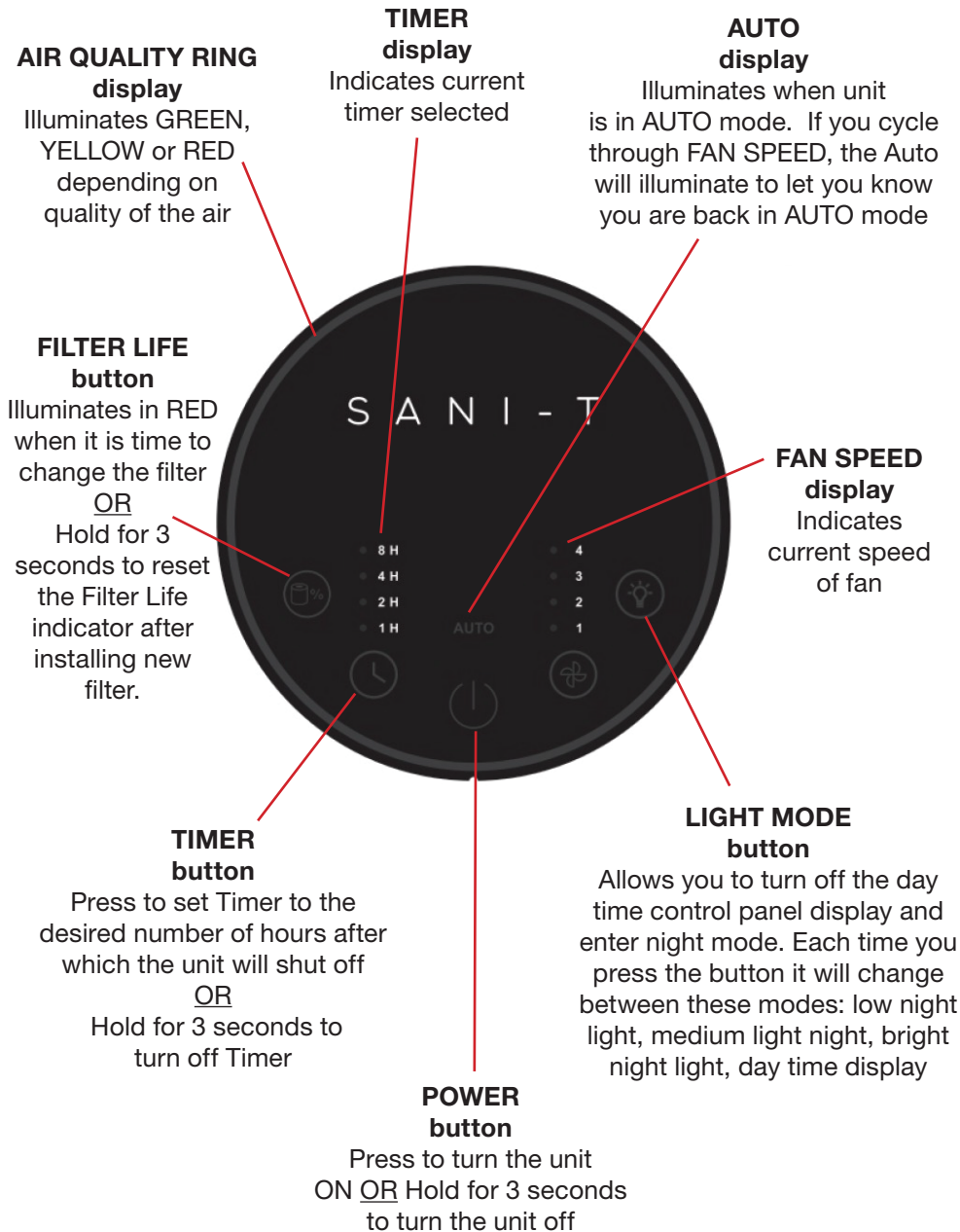

IMPORTANT! Always unplug the purifier from the electrical outlet before cleaning and/or changing the filter.

Cleaning the Air Intake

We recommend you clean this regularly for optimal performance. If not cleaned regularly, it may reduce the performance of the air purifier.

Remove the Base/Filter cover from bottom of purifier and take out the filter. Use a handheld vacuum attachment or a dry, soft cloth to remove any dust/dirt particles from the air intake holes.

Filter Maintenance

The filter life is 3,000 hours. If used in AUTO mode the filter will last approx. 4 months. When the remaining filter life reach 10%, the Filter Life button will display RED to alert that it needs to be replaced.

For optimal performance, we recommend replacing the filter within 2 weeks of the Filter Life button turning RED.

TROUBLESHOOTING

The unit is plugged in but not running:

- Make certain that the electrical outlet is operational.
- Press the power button to turn the unit on.

The unit is plugged in AND turned on but not running:

- Is the filter installed? The unit will not run without a filter.

The fan is running on high in AUTO mode for extended period:

- Ensure you have cleaned the Air Intakes from the inside (See Cleaning section).
- Ensure the windows and doors to outside are closed. Turn unit off while the windows and doors are open. Once closed, resume use of unit.
- Check if there are unsealed chemical containers nearby. Example: materials like paints, disinfectants, nail polish remover and other similar items with strong odors (VOCs) will cause the unit to run high.

REPLACING THE FILTER

We recommend ordering a new filter when there is approx. 25% life left in the current filter. When the filter needs to be replaced, the Filter Life button will illuminate in RED to indicate a replacement filter is needed.

Unplug the unit from the electrical outlet and gently place it upside down to access the filter cover on the bottom of the unit.

When the filter cover is locked, the arrow will be pointing to the FULL CIRCLE. Turn the filter cover to the left to unlock it. The arrow will point to the OPEN CIRCLE when unlocked.

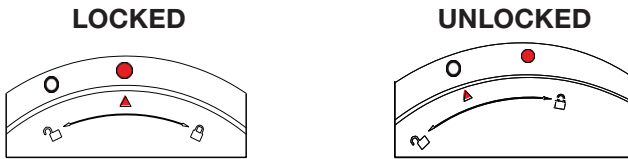

Once the filter cover is unlocked. Lift off of the cover. Reach in and remove the filter. Insert new filter in the same direction (opening of filter should be in the middle of purifier and handle of the filter should be at the bottom where the filter cover is).

Replace the filter cover and turn to the right to lock. Ensure the cover is locked before turning the filter back over to its feet. Plug the unit back into the electrical outlet and turn the power on.

IMPORTANT! Press and hold the Filter button for 3 seconds to reset the status for the new filter.

	
FILTER LIFE BUTTON STATUS COLOR:	
WHITE	Filter is OK
RED	Change the filter

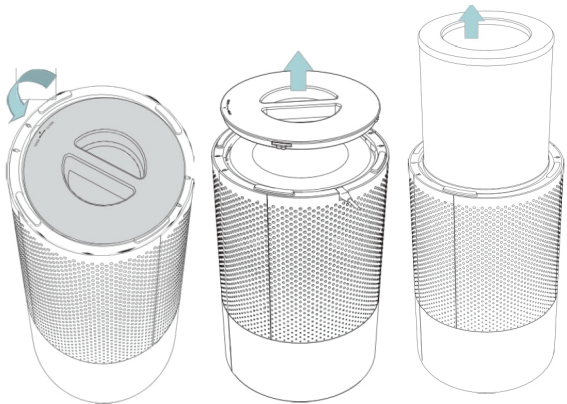

FREQUENTLY ASKED QUESTIONS

Does this unit emit ozone?

No, Sani-T air purifiers do not emit any ozone.

How often do I need to change the filter?

The filter life is 3,000 hours. If used in Auto Mode, the filter will last approx. 4 months

How do I know when I have to change the filter?

The Filter Life button will turn RED to alert you that it needs to be replaced.

Can I wash the filter?

No. The filter cannot be washed. It must be replaced with a new filter.

Where can I buy replacement filters?

We have a subscription service available to ensure you never run out. You can subscribe for automatic shipments at 3, 6 or 12 month intervals depending on how often you need additional filters. Contact our customer service team for information or visit: www.smartlivinghg.com/parts You can also purchase replacement filters through the same retailer as the purifier or buy single replacements via our customer service.

How often should the unit be cleaned?

This will depend on the environment but we recommend checking it monthly and cleaning as needed.

What the number for the AQI Color mean?

The numbers in this display are Air Quality Index levels as determined by the EPA (Environmental Protection Agency). Below is a simple summary.

AQI	Air Status
0 - 50	Air quality is good for everyone
51 - 100	Acceptable for most but may cause minor irritation for highly sensitive individuals
101 - 150	Acceptable for most but unhealthy for sensitive individuals
151 - 200	Unhealthy for everyone
201 - 300	Very unhealthy for everyone
300+	Hazardous for everyone

WARRANTY INFORMATION

In order to register your warranty with us, please list out the information in the warranty box below and email the completed information to customerservice@smartlivinghg.com

Or you can register online at:
smartlivinghg.com/registration

Name	
Email	
Model No.	SAN-385
Product Name	Sani-T Compact Air Purifier
Purchase Date	
Order Number	
Retailer Purchased From	

Smart Living Home & Garden offers a 1 Year Limited Manufacturer's Warranty from the original date of purchase on products shipped from authorized distributors and retailers. The warranty covers products which are properly used and regularly maintained as required. If the product fails due to a defect in material or workmanship, we will replace the defective parts or unit free of charge. Please unpack and inspect the entire product upon receipt. Report any broken or missing pieces within five (5) business days of receipt to our customer service department and we will provide replacement parts free of charge. Please do not discard any damaged parts until instructed to do so by our customer service department. Warranty does not cover filters which need to be replaced on a regular basis.

**For assistance with this product,
please reach out to our customer service team.
Most issues can be easily resolved over the phone or via email.**

Tel: **813.343.5775** (Mon-Fri 9am – 5pm EST)
Email: **customerservice@smartlivinghg.com**

**You can also visit our website to view the FAQs,
video walk throughs or to order replacement filters.**

Website: **<https://smartlivinghg.com>**
FAQs: **<https://smartlivinghg.com/faq>**
Parts: **<https://smartlivinghg.com/parts>**

smartLiving
home & garden

Sani-T is a Smart Living Home & Garden brand ©2021 V21.0

Telephone: +1 813 343 5775

Email: customerservice@smartlivinghg.com

Web: www.smartlivinghg.com

Smart Living Home & Garden

