

OWNER'S MANUAL

B200 196cc

GAS POWERED MINIBIKE



POWERSPORTS



POWERSPORTS

4120 E. Scyene Road, Mesquite, Texas 75181

champmoto.com



CAUTION

This Minibike was shipped without engine oil. Always fill with the correct amount and grade of engine oil as listed in the owner's manual.

WARNING

NEVER ATTEMPT TO START THIS MINIBIKE WITHOUT READING AND UNDERSTANDING THE OWNER'S / OPERATOR'S MANUAL. THE OWNER'S OPERATOR'S MANUAL PROVIDES INFORMATION ON SAFETY, PARTS, FUNCTIONS, PRE-RIDE INSPECTION, STARTING AND MAINTENANCE

Provincial/Municipal governments have different regulations pertaining to owning and operating an off-road vehicle, learn the regulations in your area.

4120 E. Scyene Road, Mesquite, Texas 75181
champmoto.com



@colemanpowersportsusa



@colemanpowersports_usa



Coleman Powersports

III. Limited Liability

A. The liability of Tao Motor under this emission control system warranty is limited solely to the remedying of defects in material or workmanship by an authorized Tao Motor's dealer at its place of business during customary business hours. This warranty does not cover inconvenience or loss of use of the vehicle or transportation of the vehicle to or from the Tao Motor's dealer. Tao Motor shall not be liable for any other expenses, loss or damage, whether direct, incidental, consequential or exemplary arising in connection with the sale or use of or inability to use the vehicle for any purpose. Some states do not allow the exclusion or limitation of any incidental or consequential damages, so the above limitations may not apply to you.

B. No express emission control system warranty is given by us except as specifically set forth herein. Any emission control system warranty implied by law, including any warranty of merchantability or fitness for a particular purpose, is limited to the express emission control system warranty terms stated in this warranty. The foregoing statements of warranty are exclusive and in line of all other remedies. Some states do not allow limitations on how long an implied warranty lasts so the above limitations may not apply to you.

C. No dealer is authorized to modify this Tao Motor Limited Emission Control System Warranty.

IV. Legal Rights. This warranty gives you specific legal rights, and you may also have other rights 16 which vary from state to state.

V. This emission control system warranty is in addition to the standard limited warranty for all vehicles.

VI. Additional Information. Any replacement part that is equivalent in performance and durability may be used in the performance of any maintenance or repairs. However, Tao Motor is not liable for these parts. The owner is responsible for the performance of all required maintenance. Such maintenance may be performed at a service establishment or by any individual. The warranty period begins on the date the motorcycle is delivered to an ultimate purchaser.

Tao Motor Inc.

2201 Luna Road, Carrollton, TX 75006
U.S.A
TEL: 888-908-3816 FAX: 214 635 3985

WARNING

Operating, servicing and maintaining a passenger vehicle or off-road vehicle can expose you to chemicals including engine exhaust, carbon monoxide, phthalates, and lead, which are known to the state of California to cause cancer and birth defects or other reproductive harm.

To minimize exposure, avoid breathing exhaust, do not idle the engine except as necessary, service your vehicle in a well-ventilated area and wear gloves or wash your hands frequently when servicing your vehicle. For more information go to www.P65Warnings.ca.gov/passenger-vehicle

To the Owner

Congratulations on your purchase of a Coleman Powersports Off-Road Mini Bike. This

Owner's/Operator's manual will provide you information regarding safe operation, operational instructions, maintenance and care. Fully understanding this manual and following all of the instructions herein will provide the knowledge needed to have safe and enjoyable operation.

For questions regarding operation and maintenance of this Off-Road mini bike, please visit Coleman Powersports visit www.powgrp.com.

Safety - Notice to parents

Children differ in skills, physical abilities, and judgment. Some children may not be able to operate this mini bike safely. Parents should supervise their child's use of the mini bike at all times. Parents should permit continued use only if they determine that the child has the ability to operate the mini bike safely.

THIS MINI BIKE IS NOT A TOY AND COULD BE HAZARDOUS TO OPERATE.

Reading the Owner's/ Operator's Manual

It is important this manual is read from cover to cover carefully by the owner and all operators. Parents should review the manual carefully with their children. Never allow anyone to operate the mini bike without first reading and understanding the Owner's/Operator's manual.

This Owner's/ Operator's manual should be a permanent part of the mini bike and should remain with the vehicle at all times. The manual should also remain with the vehicle if sold.

If you use your vehicle in any type of sanctioned competitive event, this warranty is immediately and completely void.

If you have any questions regarding your warranty rights and responsibilities, you should contact Tao Motor Inc., 2201 Luna Road, Carrollton, TX 75006, TEL: 972-512-8866

Tao Motor warrants that each new 2021 and later Tao Motor's OFMC:

- A. is designed, built and equipped so as to conform at the time of initial retail purchase with all 15 applicable regulations of the United States Environmental Protection Agency, and
- B. is free from defects in material and workmanship which cause such vehicle to fail to conform with applicable regulations of the United States Environmental Protection Agency for the periods specified above.

I. Coverage. Warranty defects shall be remedied during customary business hours at any authorized Tao Motor's dealer located within the United States of America in compliance with the Clean Air Act and applicable regulations of the United States Environmental Protection Agency. Any part or parts replaced under this warranty shall become the property of Tao Motor.

II. Limitations This Emission Control System Warranty shall not cover any of the following:

A. Repair or replacement as a result of

- (1) accident,
- (2) misuse,
- (3) repairs improperly performed or replacements improperly installed,
- (4) use of replacement parts or accessories not conforming to Tao Motor's specifications which adversely affect performance and/or
- (5) use in competitive racing or related events.

B. Inspections, replacement of parts and other services and adjustments required for required maintenance.

C. Any vehicle equipped with an odometer or hour meter on which the odometer mileage or hour meter reading has been changed so that actual mileage cannot be readily determined.

EMISSION CONTROL SYSTEM WARRANTY

Below is the emission control system warranty printed in the owner's manual, the copy of the owner's manual is available upon your request.

YOUR WARRANTY RIGHTS AND OBLIGATIONS

The U.S. Environmental Protection Agency, and **Tao Motor Inc.** (hereinafter "**Tao Motor**") are pleased to explain the emission control system warranty on your 2021 Model Year OFMC. New vehicle must be designed, built and equipped to meet U.S. EPA Federal over the full useful life. Tao Motor must warrant the emission control system on your vehicle for 5,000 km or for 30 months, whichever comes first, provided that there has been no abuse, neglect or improper maintenance of your vehicle.

Your emission control system may include parts such as the carburetor or fuel injection system, the ignition system, catalytic converter and engine computer, if it is equipped. Also included may be hoses, belts, connectors and other emission-related assemblies.

Where a warrantable condition exists, Tao Motor will repair your vehicle at no cost to you, including diagnosis, parts and labor.

If an emission-related part on your vehicle is defective, the part will be repaired or replaced by Tao Motor. This is your emission control system defects warranty.

NOTICE! Use of any Tao Motor vehicles in any type of competitive event completely and absolutely voids this and all other warranties offered by Tao Motor.

OWNER'S WARRANTY RESPONSIBILITIES

As the vehicle owner, you are responsible for the performance of the required maintenance listed in your owner's manual. Tao Motor recommends that you retain all receipts covering maintenance on your vehicle, but Tao Motor cannot deny warranty solely for the lack of receipts or for your failure to ensure the performance of all scheduled maintenance.

You are responsible for presenting your vehicle to the Tao Motor's dealer as soon as a problem exists. The warranty repairs should be completed in a reasonable amount of time, not to exceed 30 days.

As the vehicle owner, you should be aware that Tao Motor may deny your warranty coverage if your vehicle or a part has failed due to abuse, neglect, improper maintenance or unapproved modifications.

To emphasize special important information in the manual, please note the following:



This is the alert symbol. The symbol means **ATTENTION!, BECOME ALERT!, YOUR SAFETY IS INVOLVED.**

To emphasize important safety information, the word **WARNING**, with the alert symbol, has special meaning.:



Indicates a potential hazard that could result in **SEVERE INJURY or DEATH** to the operator, bystander or person inspecting or repairing the unit.

To emphasize important information, the word **CAUTION** has special meaning.:

CAUTION:

Indicates special precautions that must be taken to avoid damage to the unit.

To emphasize important information, the word **NOTE** has special meaning.:

NOTE:

Indicates key information to make procedures easier or clearer to understand.



The first part will identify a **POTENTIAL HAZARD**.

The second part will describe **WHAT COULD HAPPEN** if the warning or caution is ignored.

Coleman Powersports is concerned about the environment and believes in conserving and protecting all natural resources. For this reason, owners should recycle, trade in, or dispose as appropriate, oil and tires.

This manual is based on the latest product information available at the time of publication. Coleman Powersports has a policy of continually improving its products. Due to improvements, or other changes, there may be some discrepancies. We reserve the right to make product changes at any time, without notice and without incurring any obligation to make the same or similar changes to vehicles previously built or sold.

TABLE OF CONTENTS

COLEMAN POWERSPORTS WARRANTY..	2	AIR FILTER.....	18
IMPORTANT SAFETY LABELS.	4	SPARK PLUG.	19
LOCATION	4	ENGINE OIL.....	20
LABELS.....	5	CHECKING.....	20
SAFETY	6	CHANGING.	20
DESCRIPTION AND PART LOCATIONS...	7	THROTTLE CABLE ADJUSTMENT	21
DESCRIPTION AND PART FUNCTIONS..	8	FUEL HOSE INSPECTION	21
RIGHT HAND THROTTLE GRIP.....	8	VALVE CLEARANCE.....	21
ENGINE STOP SWITCH.....	8	BRAKES	22
LEFT HAND BRAKE LEVER.	8	CHAIN AND SPROCKET.....	23
CHOKE OPERATION	9	INSPECTION.....	23
FUEL VALVE OPERATION	9	TENSION AND ADJUSTMENT	23
FUEL CAP.....	9	CLEANING AND LUBRICATION.....	24
STARTER RECOIL CORD.....	9	CLEANING AND INSPECTING CENTRIFUGAL	
OIL FILL PLUG.....	9	CLUTCH.	24
FUEL AND OIL.....	10	TIRES.....	25
FUEL.....	10	REPLACING.....	25
ENGINE OIL.....	10	STORAGE.....	26
PRE RIDE INSPECTION	11	RETURNING TO SERVICE.....	26
RIDING MINI BIKE.....	12	WASHING THE MINI BIKE.....	27
HELMET, EYE PROTECTION AND		TRANSPORTING.....	27
PROTECTIVE CLOTHING.....	12	TROUBLE SHOOTING.....	28
STARTING THE ENGINE.....	13	SPECIFICATIONS.....	29
STARTING OFF	14	FRAME AND ENGINE NUMBER	
LOAD GUIDELINES.....	15	LOCATION	30
MAINTENANCE.....	16	EMISSION CONTROL SYSTEM	
MAINTENANCE CHART.....	17	WARRANTY.....	31

FRAME AND ENGINE NUMBER LOCATION

The Vehicle identification number and the engine number are needed when calling for parts, service center help or when registering your Mini Bike. Locate the numbers and list the numbers below for reference.

The 17 digit Vehicle Identification Number (VIN) is located on the vertical tube on the neck of the mini bike

Vehicle Identification Number

--	--	--	--	--	--	--	--	--	--	--	--	--	--	--	--	--

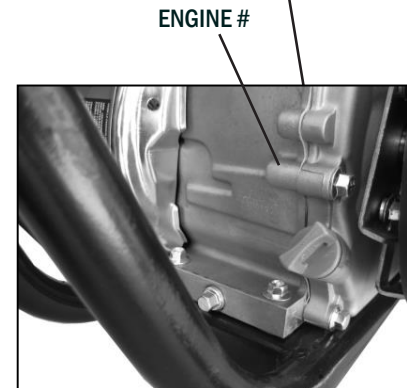

The engine number is located on the bottom front portion of the Mini Bike Engine.

Engine Number

SPECIFICATIONS

<u>Engine</u>	<u>Tires</u>
Displacement 196cc	Front Tire Size AT19x7-8
Starting Recoil Cord	Rear Tire Size AT19x7-8
Spark Plug Type F6TC	
Cooling Air cooled	<u>Dimensions and Weights</u>
Ignition Type T.C.I	Length 63.5in (1615mm)
Cylinder head config. OHV	Height 36in. (915mm)
Number of Cylinder Single	Width 29.5in.
Combustion Cycle 4-stroke	(750mm)
Bore and Stroke 68 x 54mm	Wheelbase 44.5in.
Compression Ratio 8.5:1	(1130mm)
Power 3.8kw @ 3600rpm	Vehicle Wt. 154lbs (70kg)
Rated Torque 11Nm @ 2500rpm	Weight Cap. 200lbs (91kg)
Idle Speed 1600 ± 100 rpm	Ground Clearance 6.3in
Top Speed 30mph (37km/h)	(160mm)
<u>Transmission</u>	<u>Fuel</u>
Drive System Type Chain Drive	Gas Tank Capacity 1.06gal.
Gear Ratio 10:1	
Centrifugal Clutch	Fuel type (4L) Unleaded 87
<u>Suspension</u>	octane or higher
Front Type Low pressure tires	<u>Oil</u>
Rear Type Low pressure tires	Oil Capacity .63qt. (.6L)
<u>Braking</u>	Oil Type SAE 15W-40
Brakes (Type) Hydraulc disk	

COLEMAN POWERSPORTS LIMITED WARRANTY

This Warranty is NOT the Emissions Control Warranty

Please note this is a general Limited Warranty for this product. It IS NOT an Emissions Control Warranty. Please see the Emissions Control Warranty in this manual for warranties covering Emission components. The Emissions Control Warranty can be found on page 31.

The Warranty

Coleman Powersports offers the following warranty to the initial purchaser of this new Coleman Powersports product. The initial purchaser is defined as the first person to purchase a new Coleman Powersports product from an Authorized Retailer.

The limited warranty period for this product is 90 days from the date of purchase shown on the original sales receipt.

What is a Defect?

The Product is warranted to be free from manufacturing defects in material and workmanship for a period of 90 days from the date of purchase shown on the sales receipt. During this period of time Coleman Powersports will, at its option, either repair, refund purchase amount, or replace any original Coleman Powersports unit/part which is covered by this warranty and is proven to be defective in workmanship or material.

To qualify for this warranty the part:

1. Must have been purchase from Coleman Powersports or from an authorized Coleman Powersports Retailer.
2. Must have been used in a manner consistent with the intended use for the vehicle.

This warranty does not apply to any vehicle which is used in competition or used in a manner not consistent with the intended use for the vehicle which would also include rental or commercial use.

Who Can Perform Repairs Under this Warranty?

Repairs under this warranty should be performed by an authorized Coleman Powersports retailer or comparable servicing dealer.

How to get service under this warranty

To get warranty service visit Coleman Powersports at www.champmoto.com or call 888-405-8725 for the location of your local servicing retailer / dealer. Please do not return the product to the retailer where the product was purchased unless instructed to do so by Coleman Powersports. The retailer of this product does not make any warranty of its own and has no authority to implement this warranty on behalf of Coleman Powersports without the approval of Coleman Powersports. A COPY OF YOUR SALES RECEIPT IS REQUIRED FOR WARRANTY SERVICE.

TROUBLESHOOTING

What this Warranty Does Not Cover

This warranty does not cover the following

1. Damage due to lack or improper maintenance as describe in this manual.
2. Damage which is caused by normal use and not cause by a defect in materials or workmanship.
3. Use of the product which is not consistent with the intended use as described in the operating instructions.
4. Any expendable maintenance items which needs replacement or service as normal maintenance requires unless these normal maintenance items become defective prior to their normal life due to a material defect or a defect in workmanship.
5. Any product which has been altered or modified in a manner not consistent with the original design of the product or in a manner not approved by Coleman Powersports.
6. Tires
7. Damage or failures due to abuse, neglect, or misuse of the product.

Limitations of this Warranty

This warranty does not cover and Coleman Powersports disclaims any responsibility for:

1. Loss of time or loss of use of the product.
2. Transportation costs to and from the authorized center.
3. Other loss or damage to other equipment or personal items.

Length of Implied Warranties

Any implied warranties are limited to the duration set forth in this warranty. Coleman Powersports does not make any claim as to the merchantability or fitness for a particular purpose which would extend longer than the duration of this written warranty.

Check your State Laws as some State Laws do not allow limitations as to the duration of an implied warranty. Some States may also not allow limitation or exclusions based on incidental or consequential damages.

Trouble	Possible cause	Solution
Engine will not start	<ul style="list-style-type: none"> • Low fuel • Stale or contaminated fuel. • Fuel valve is in the "OFF" position • Loose spark plug • Spark plug fouled or defective. • Spark plug gap is incorrect • Spark plug cap is not attached • Choke is not in the "ON " (left) position for starting a cold engine. • Problem with the electrical system • Air filter dirty • Valves not adjusted properly 	<ul style="list-style-type: none"> • Fill with fresh fuel • Have a service center flush and fill with fresh fuel. • Place fuel valve in the "ON" position. • Tighten spark plug • Clean or replace plug • Gap the plug • Attach spark plug cap • Place choke in the "ON" (left) position • Take to a service center for repair • Clean or replace air filter • Take to a service center for repair
Engine stalls or runs erratically	<ul style="list-style-type: none"> • Low fuel • Stale or contaminated fuel • Choke is left in the "ON" (left) position • Spark plug is fouled or defective • Spark plug gap is incorrect • Spark plug cap is loose • Carburetor is clogged or has water in it • Idle is not adjusted properly • Problem with the electrical system • Air filter dirty • Valves not adjusted properly 	<ul style="list-style-type: none"> • Fill with fresh fuel • Have a service center flush and fill with fresh fuel. • Place the Choke in the "OFF" (right) position. • Clean or replace plug • Gap the plug • Secure the spark plug cap • Take to a service center • Take to a service center • Take to a service center for repair • Clean or replace air filter • Take to a service center for repair

Washing the Mini Bike

1. Wash mud and dirt off Mini Bike with low pressure water from a hose. Do not use high pressure nozzles, this could allow water to enter the engine causing damage.

2. Wash Mini Bike using a mild detergent or car soap using a sponge, soft rag or brush. Do not use any cleaning materials that could scratch the surfaces.

Note: Be careful not to allow water to enter the muffler outlet, air filter intake, brake cable, throttle cable or switches.

Transporting

1. Make sure fuel valve (1) is turned to the OFF (left) position.

2. Drain carburetor by turning fuel valve(1) to the off position and opening the drain screw (2). Allow all fuel to drain from the carburetor. Once fuel is drained, re-tighten drain screw (2).

Note: Make sure to drain fuel in a proper storage container.

3. Transport the Mini Bike with the Mini Bike in the upright position tied down securely.



IMPORTANT LABELS

LOCATION

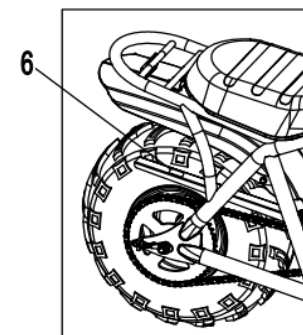
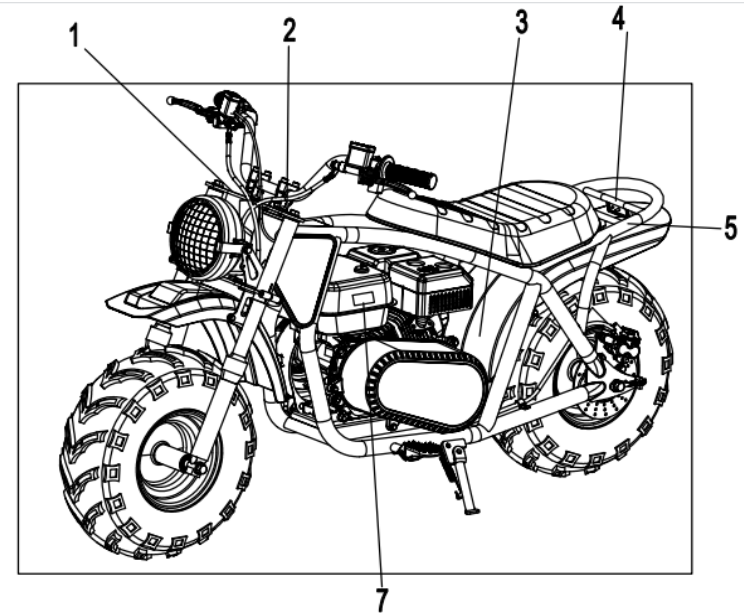

Warning Labels

1



2

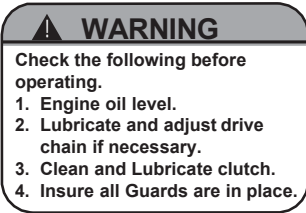

4

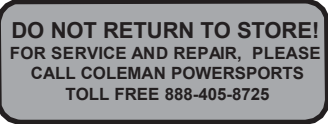

5

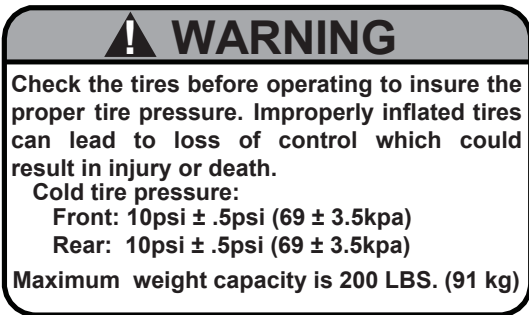

7

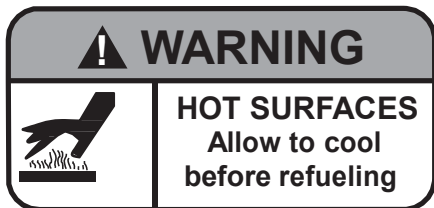

3



6



Storage

If the Mini Bike is left unused for an extended period of time proper storage maintenance is required.

1. Wash Mini Bike thoroughly, then wax painted parts with a non abrasive auto wax. Coat vinyl seat and rubber parts with a vinyl/rubber protectant.

Note: Keep water away from air intake and muffler outlet while washing to avoid water from entering the engine and/or components.

2. Drain carburetor by placing fuel valve (1) to the off position and opening the drain screw (2). Allow all fuel to drain from the carburetor. Once fuel is drained, re-tighten drain screw (2).

Note: Make sure to drain fuel in a proper storage container.

3. Fill fuel tank to full with gasoline mixed with fuel stabilizer as recommended by the fuel stabilizer manufacture. **Note:** Fuel stabilizer can be purchased at most motorcycle shops and auto parts stores.

4. Remove spark plug and pour 1 tablespoon of motor oil in the spark plug hole. Re-install spark plug.

5. Place the starter button to the off position and pull the start recoil cord a few times. This is to coat the inside cylinder head with oil.

6. Fill tires with correct air pressure.

7. If possible, store Mini Bike in a shed or garage with a cover to protect from dust, dirt and humidity. If the Mini Bike must be stored outdoors, cover completely with a good waterproof cover.

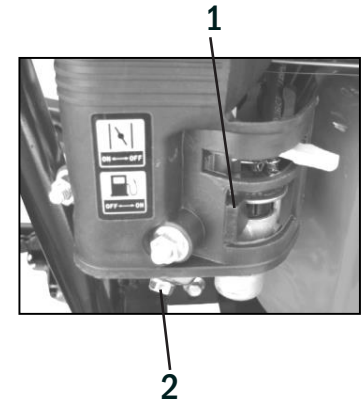

Returning to service

1. Wash Mini Bike thoroughly.

Note: Keep water away from air intake and muffler outlet while washing to avoid water from entering the engine and/or components.

2. Drain engine oil and replace with fresh clean oil as listed in this manual.

3. Review this owner's manual and follow the pre-ride inspection procedures.

4. Start engine by following the starting procedures in this manual.

MAINTENANCE

Tires

Inspect tires before each ride, this should include the following:

1. Inspect for cracks or leaks
2. Inspect tread depth. If tread depth is below 4mm (.16 in.) replace the tire.
3. Check tire pressure. Incorrect tire pressure can affect the handling, rider comfort, steering, tire life and traction. Always check the tire pressure before each ride.

Tire pressure

Front tires: 10psi (69 kpa)

Rear tires: 10psi (69 kpa)

Tire size:

Front tires: AT19x7-8

Rear Tires: AT19x7-8

Replacing tires

Always replace tires with type and size listed in this manual.

Always use the correct tools when replacing tires. The bead and sometimes the rim can be damaged by using the wrong type of tools. It is usually best to have tires replaced by an authorized service center. Service centers have the correct equipment and expertise to change tires without causing damage.

Punctures to tires can usually be repaired by using plug type patches. Plug type patches cannot repair tires that have been cut. If the tire has been cut or has a puncture in a location or size that cannot be repaired, replace the tire.

Be prepared for flat tires, always carry a plug type patch kit and air pump with you.



Minimum tread
4mm (.16 in.)



⚠ WARNING

Operating this Mini Bike with worn tires could be hazardous. Operating this Mini Bike with worn tires will reduce traction which could result in an accident.

Never operate this Mini Bike with tires that have a tread depth of less than 4mm (0.16 in.)

⚠ WARNING

Operating this Mini Bike with improper tire sizes or pressure could be hazardous. Operating this Mini Bike with improper tire sizes or pressure could result in loss of control of the Mini Bike which could result in an accident. Never operate this Mini Bike with improper tire sizes or pressure.

SAFETY

This Mini Bike is recommended for riders 13 and older.

Always wear a certified DOT motorcycle type helmet that fits properly, over the ankle boots, eye protection, gloves, long sleeve shirt and long pants while operating this mini bike.

Never allow a passenger on this mini bike. This mini bike is designed for one operator and no passengers.

Never operate this mini bike on paved surfaces and/or public roads. Pavement may cause the mini bike to become unstable. The tires on the mini bike are for off-road use only.

Always go slowly and pay attention to unfamiliar terrain. Be alert to changing terrain conditions when operating the Mini bike.

Never operate with long hair or loose clothing unsecured. Long hair and loose clothing can get caught in moving parts of the mini bike.

Never take drugs or alcohol before or during operation of this mini bike.

Never traverse, climb or go down a hill that is too steep. Avoid hills with loose or slippery terrain.

Never attempt wheelies, jumps or any other type of stunts on this mini bike.

Always follow the pre-ride inspection procedures and maintenance procedures located in this manual before use.

Always go slow on terrain that is not familiar, be alert, an obstacle could come up unexpectedly.

Always keep both hands on the handlebars and both feet on the foot pegs, doing so will help the operator be ready for unexpected situations.

Do not operate in fast flowing water. Water can affect the braking performance of the mini bike. Check braking performance after exposure to water, it may be necessary to apply the brakes allowing friction to dry out the pads.

Always Check the throttle to ensure it works properly and "snaps back" to idle prior to starting the mini bike.

DESCRIPTIONS AND PART LOCATIONS

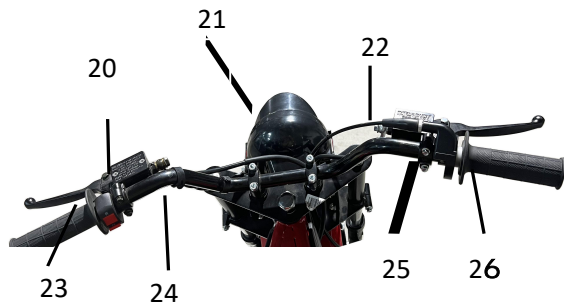
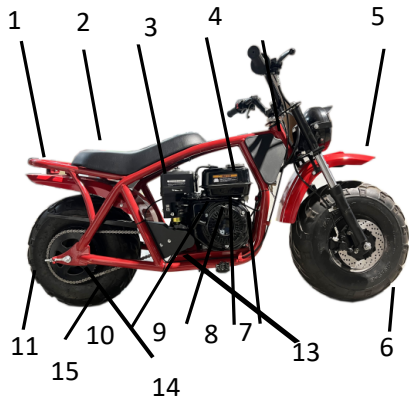

1. Rear Fender
2. Seat
3. Air filter assembly
4. Fuel Tank and Cap
5. Front Fender
6. Front Wheel
7. Starter Recoil Cord
8. Fuel Valve
9. Choke Lever
10. Carburetor
11. Rear Wheel
12. Muffler
13. Chain Guard
14. Chain adjustment bolts1
15. Chain
16. Kick Stand
17. Foot Pegs
18. CVT Cover
19. Front Shock Absorption2
20. Rear Brake Lever
21. Headlight
22. Throttle Cable
23. Left Hand Brake Grip
24. Engine Stop Switch
25. Throttle Grip
26. Right hand Brake Grip

MAINTENANCE

Torque Converter Cleaning and lubrication

To help ensure maximum life out of the Torque Converter, it is important to clean and lubricate the front drive of the Torque Converter after every 10 hours of operation. To clean and lubricate, follow the instructions below.

1. Make sure engine is not running and that the engine and clutch has had time to cool.
2. Remove CVT cover (1).
3. Remove front drive (2) and take apart.
4. Clean front drive by spraying with a carburetor or brake cleaner and wiping dry with a rag. Using a graphite type dry lubricant, sparingly lubricate inner components.
5. RE-INSTALL THE TORQUE CONVERTER COVER BEFORE STARTING OR OPERATING THE GO-KART.

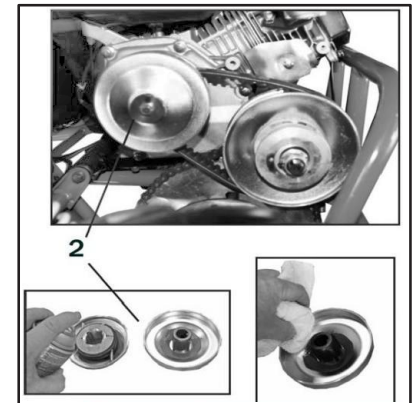
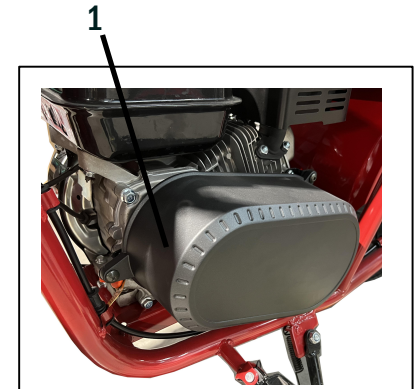

⚠ WARNING

Performing maintenance and inspection on the Torque Converter while the engine is running could be hazardous. Performing maintenance and inspection on the Torque Converter while the engine is running could result in getting body parts or clothing caught in moving parts, or could result in touching hot items which could result in severe injury.

⚠ WARNING

Operating the Go-Kart without the Torque Converter cover in place could be hazardous. Operating the Go-Kart without the Torque converter cover could result in getting body parts or loose clothing caught in moving parts which could result in severe injury. Never Start or operate the Go-Kart without the Torque Converter cover in place.

MAINTENANCE

Chain

Chain and Sprocket Inspection

Inspect the drive chain for wear, rust, bound links, proper lubrication and proper tension.

If the drive chain has a problem correct or replace. Contact a service center for chain replacement.

A worn drive chain could also mean the sprockets may be worn.

Look for the following on the sprockets (1): Worn teeth, broken or damaged teeth, Loose sprocket mounting nuts.

If the sprocket shows signs of wear, contact a service center for replacement.

Chain tension

Check the tension of the chain. The chain (1) tension should be 1/2 - 3/4 in. (15-20mm)

Chain tension (slack) adjustment

1. Loosen bolts under engine (2) on the rear axle assembly.

2. Adjust chain tension by turning the tension nuts (3) (Note: tension nuts are located on both sides of the mini bike.) Clockwise will tighten the chain. Counter clockwise will loosen the chain.

3. Once the chain is at the correct tension re-tighten axle bolt (2).

4. Re-check chain tension.

Chain lubrication

Lubricating the chain before each ride will help to ensure maximum life of the chain and sprockets.

Instructions for cleaning and chain lubrication:

1. Clean chain with a chain cleaner.
2. Lubricate chain with chain lube.

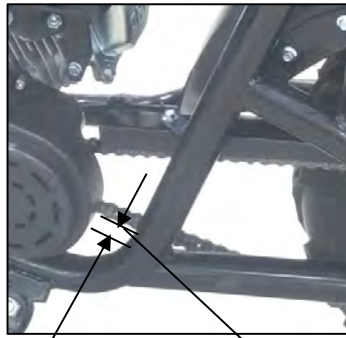

1/2 - 3/4 in.
(15-20mm)



2 3

DESCRIPTION AND PART FUNCTIONS

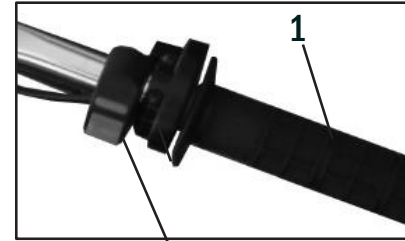

Throttle Grip (1): The engine speed is regulated by the position of the right throttle grip. Throttle is increased by turning the throttle grip toward the operator. Engine speed is decreased by turning the throttle grip away from the operator.

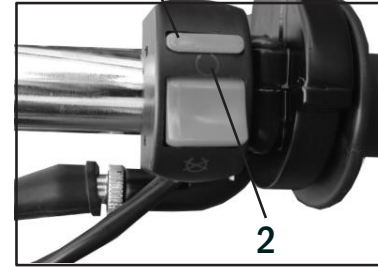

Engine Stop Switch (2): Mini Bike engine can start when the Engine stop switch is placed in the (on) position. Engine will shut off and the engine will not start when the switch is placed in the (off) position.

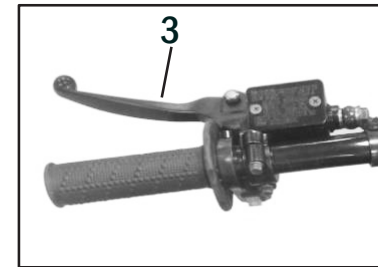

Left hand brake lever (3): The rear brake is applied when the left hand brake lever is pulled toward the hand grip.

DESCRIPTION AND PART FUNCTIONS



Choke operation

Choke Lever (1): If the engine is cold, the choke can help start the engine by placing the choke lever to the "ON" (left) position. Once engine has warmed up, place choke lever to the "OFF" (right) position.

Fuel Valve operation

Fuel Valve (2): To start the engine and run the mini bike, the fuel valve needs to be placed in the "ON" (right) position. This allows fuel to flow to the carburetor. When finished riding, and while transporting, place fuel valve in the "OFF" (left) position.

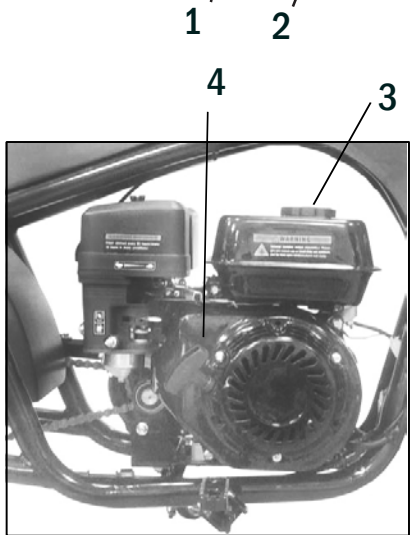

Fuel Cap

Fuel Tank Cap

To open the fuel tank cap (3), Turn the cap counter clockwise to remove. To re-install the cap, turn the cap clockwise until snug.

Starter Recoil Cord

Starter Recoil Cord (4)

To start the engine, place the on/off switch locate on the handlebars to the "ON" position and pull the Starter Recoil Cord

Oil Fill plug

Oil Fill Plug (5)

To check or add oil, open the oil fill plug/ dipstick by turning counter clockwise. To tighten, turn clockwise.

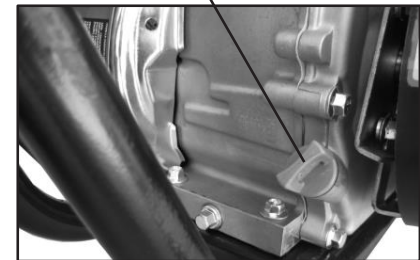

MAINTENANCE

BRAKES

This Mini Bike is equipped with rear hydraulic disk

WARNING

Failing to inspect brakes before each use could be hazardous. Inspect brakes before each use according to the pre-ride check list, make sure to follow the maintenance schedule and procedures.

BRAKE FLUID INSPECTION

Check the brake fluid level (1) for rear brakes. If fluid level is below the lower mark, inspect the brake hoses (2) for leaks or cracks. If there are no leaks, inspect the brake pads for excessive wear. If brake pads are worn, take to a service center for replacement. To add brake fluid, remove the lid (3). Use only DOT3 or DOT4 brake fluid

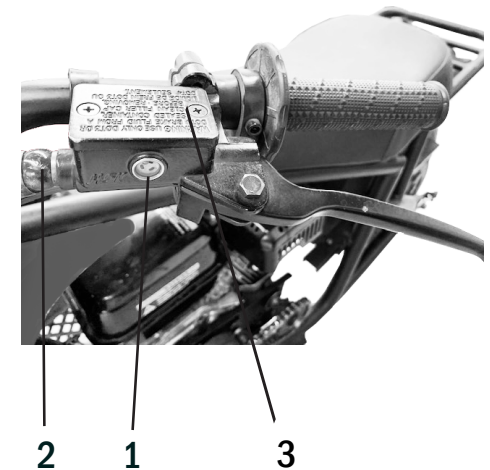

MAINTENANCE

Throttle Cable adjustment

It is important that the throttle grip have a certain amount of free play so the throttle does not rise when the handlebars are turned from left to right.

The hand grip throttle free play (2) should be .078 - .24 in (2-6 mm)



To adjust free play

1. Loosen jam nut (3)
2. Turn adjusting nut (4) to proper setting
3. Once throttle grip is at the proper free play, re-tighten the jam nut (3).

NOTE: After any adjustment, make sure throttle snaps back to idle when released.

Fuel Hose Inspection

Inspect the fuel hose for any cracks or leaks and make sure all clamps are in place. Replace the fuel hose if any defects are found.

Valve Clearance:

Adjusting the valves should be done by an authorized service center. Proper valve gap will help Mini Bike run at peak performance. Follow the valve gap adjustment intervals listed in the maintenance chart.

⚠ WARNING

Inadequate throttle play can be hazardous

The engine speed could rise when the handlebars are turned if there is not enough throttle play. This could result in loss of control.

Always check throttle play before each ride. Turn handlebars from side to side making sure throttle does not increase when doing so.

Proper Valve Clearance

Intake: 0.1 - 0.15 mm

Exhaust: 0.1 - 0.15 mm

FUEL

Never use leaded gasoline in this product. It could affect the engine's emissions and damage the engine. Mini Bike requires clean unleaded regular gasoline with a minimum octane rating of 86 or higher.

Gasoline/ Ethanol blends

A blend of unleaded gasoline with Ethanol, also known as GASOHOL, at or below 10% (E10) can be used in your Mini Bike. Ethanol greater than 10% can damage your engine and will void your warranty.

Gasoline/Methanol

Blends

A blend of gasoline with Methanol of 5% or less can be used in your Mini Bike. Do not use gasoline, under any circumstances, containing more than 5% Methanol, doing so will damage your engine and will void the warranty.

Fuel Filling

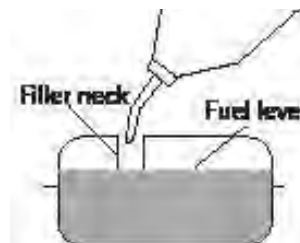

⚠ WARNING

Over filling the fuel tank can cause the fuel to expand which can cause overflow due to the heat from the engine or sun. Spilled fuel can catch fire.

Never fill the fuel tank above the bottom of the filler neck.

FUEL AND OIL

⚠ WARNING

Fuel and fuel vapor are highly flammable and toxic. You can be burned or poisoned while refueling.

Before refueling make sure to follow the procedures listed:

- 1 Shut off engine, Make sure there are no flames, sparks or heat sources close by.
- 2 Refuel only outdoors in a well ventilated area.
- 3 Do not smoke while refueling.
- 4 Wipe up any spills immediately.
- 5 Avoid breathing any fuel vapors.
- 6 Keep children and pets away.

ENGINE OIL

The recommended oil for this Mini Bike is SAE10W-30 motor oil, if this oil is not available, any of the oils on the chart below will work. Note the temperature requirements for each of the oils.

Quantity of oil - .63qt. (.6L).

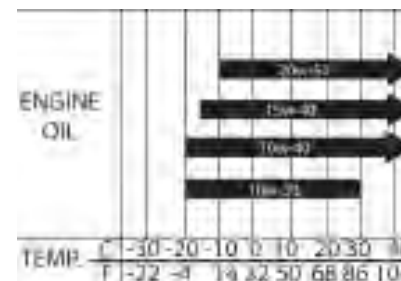

PRE-RIDE INSPECTION

Inspecting and checking the condition of the Mini Bike before each ride is important. Following the pre-ride check list will help insure the you do not have mechanical problems which could result in injury or becoming stranded. Make sure the Mini Bike is in good operating condition before each ride.

⚠ WARNING

Failing to inspect and maintain your Mini Bike could be hazardous.

Not following the pre-ride inspection procedures could result in loosing control of the Mini Bike resulting in an accident or damage to the Mini Bike

Always perform a pre-ride inspection before each ride.

⚠ WARNING

Performing maintenance and checks while the engine is running could be hazardous.

You could be severely injured by moving parts or hot surfaces.

Never perform maintenance or check procedures while the engine is running with the exception of checking the engine stop switch or throttle.

WHAT TO CHECK	CHECK FOR
Steering	<ul style="list-style-type: none"> Smoothness No restriction of movement
Brakes	<ul style="list-style-type: none"> Brake pad wear. Proper brake lever play
Tires	<ul style="list-style-type: none"> Proper tire pressure Proper tread depth Rubber has no cracks
Fuel Tank	<ul style="list-style-type: none"> Enough fuel for the ride Fuel cap secure Hoses have no signs of cracks or leaks
Throttle grip	<ul style="list-style-type: none"> Throttle grip snaps back to idle when released Operates freely Has correct free play
Engine Stop Switch	<ul style="list-style-type: none"> Switch shuts off engine when activated.
Engine Oil	<ul style="list-style-type: none"> Correct oil level
Drive Chain	<ul style="list-style-type: none"> Proper tension Lubricated No excessive wear or damage
General Condition	<ul style="list-style-type: none"> All nuts and bolts tight No rattles from engine or frame while running

MAINTENANCE

Engine Oil

The proper amount and grade of engine oil will have a great impact on the life of the engine. Checking the oil daily and changing the oil as listed in the maintenance schedule is the most important maintenance procedure for the engine.

Checking the engine oil

1. Make sure the Mini Bike is on level ground.
2. Check engine oil level by removing the oil fill plug/dipstick (1) located on bottom front left front side of the engine.
3. If engine oil is low, add oil until oil is at edge of fill hole (2). Use the correct grade of oil as listed in this manual. Do not over or under fill engine with oil, this could damage the engine.

Changing the engine oil

1. Make sure engine is warm before attempting to drain the oil. A warm engine will help the oil drain quicker.
2. Remove the oil fill plug (1)
3. Remove the drain bolt (3) located on the bottom of the engine.
4. Allow the oil to drain in an appropriate container. Note: Dispose of oil at an oil recycle center.
5. Install the drain plug and fill with the appropriate type of oil as listed in this manual. This mini bike takes .63qt. (.6L) of engine oil.
6. Re- install fill cap, Start engine and allow to run for a few minutes, Re-check oil level and fill accordingly.

⚠ WARNING

New and used oil can be hazardous

Children and pets can be harmed by swallowing new or used oil. Continuous contact with used engine oil has been found to cause skin cancer in laboratory animals

Always keep new or used oil away from children and pets.

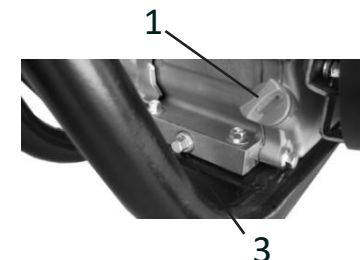
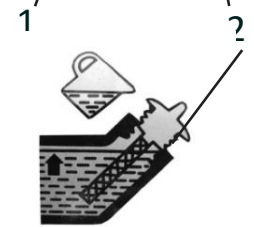
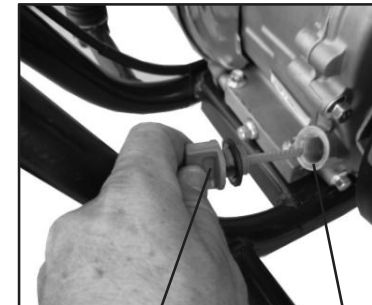

MAINTENANCE

Spark Plug

This Mini Bike comes equipped with a F6TC spark plug.

To inspect the spark plug, remove the air filter cover and element to gain access. Remove spark plug cap (1) then remove the spark plug from the engine with the spark plug tool provided.

Inspect the plug for carbon deposits and clean if necessary. If plug shows excessive carbon, replace the plug.



CAUTION

Dirt can damage the engine if it enters the spark plug hole.

Make sure the spark plug hole is covered after removing plug.

Use a thickness feeler to inspect the spark plug gap (2). The spark plug gap should be 0.6 - 0.8mm (0.024 - 0.032 in.)

Re-install the inspected plug or new plug until finger tight. Finish tightening plug with a wrench. If the plug is a new plug, tighten approximately 1/2 turn more with the wrench. If plug is an old plug, tighten approximately 1/8 turn more with a wrench.



RIDING THE MINI BIKE

HELMET, EYE PROTECTION, PROTECTIVE CLOTHING

Always wear a DOT or SNELL certified motorcycle helmet (1). A helmet helps protect against serious head injuries in the event of an accident. A helmet is the most important safety gear item you can wear. Consult with a motorcycle dealer for the correct size and type of motorcycle helmet that is right for you.

Always wear eye protection when riding a Mini Bike such as a face shield or goggles (2). While riding a Mini Bike you can be hit in the eyes by any of the following: dust, branches, rocks, debris from other riders, bugs, etc. Good eye protection as well as a helmet and protective riding gear should be mandatory when riding a Mini Bike.

Wear protective clothing: Long sleeve shirt (3), Gloves (4), Long pants (5), over the ankle boots (6).

Riding a Mini Bike exposes the rider to many hazards, wearing protective clothing can help protect the rider from injury.

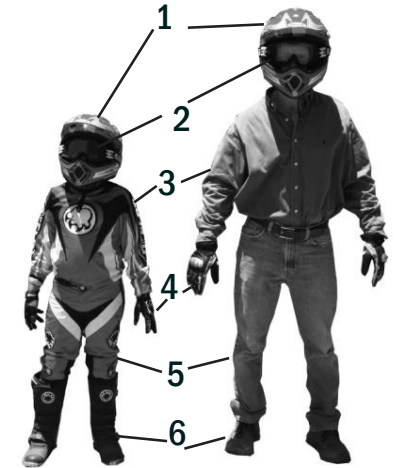

⚠ WARNING

Riding the Mini Bike without a helmet, eye protection, and protective clothing can be hazardous

Riding a Mini Bike without a helmet increases the chance of severe head injury or death in the event of an accident.

Riding a Mini Bike without eye protection such as a face shield or goggles could result in severe injury in the event of an accident.

Riding a Mini Bike without protective clothing; over the ankle boots, long pants, gloves, long sleeve shirt could result in severe injury in the event of an accident.

Always wear a Helmet, eye protection, long pants, long sleeve shirt, over the ankle boots and gloves when riding the Mini Bike.

RIDING THE MINI BIKE

STARTING ENGINE

To start the engine

1. Place the fuel valve (1) in the "ON" (right) position.
2. If engine is cold, place the choke lever (2) in the "ON" (left) position.
3. Place the ON/OFF switch (3), located on the handlebars, in the (on) position.
4. Pull the starter recoil cord (4) to start the engine.
5. Once engine has warmed up for a few minutes, place the choke lever (2) back to the "OFF" (right) position.

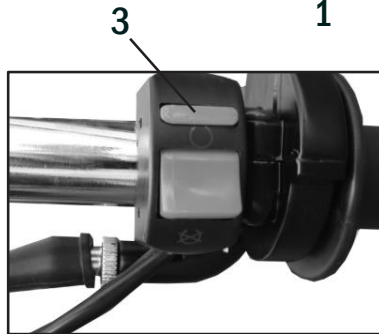
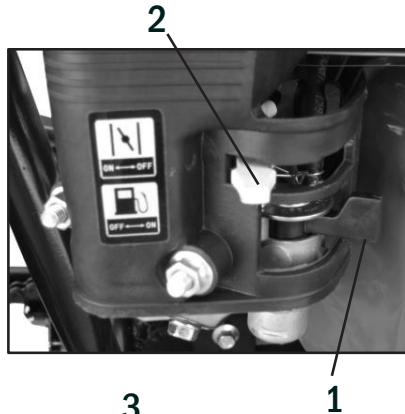

⚠ WARNING

Starting or running the Mini Bike in an enclosed area such as a garage or shed where there is no ventilation is hazardous

Inhaling exhaust fumes from the Mini Bike can cause severe injury or death

Never start or run the Mini Bike in an inclosed environment where there is no ventilation. Always start and run outdoors.

MAINTENANCE

Air Filter

The air cleaner element needs to be cleaned or replaced periodically (see chart for cleaning/replacement intervals). The air filter element will need to be cleaned more often if Mini Bike is ridden in muddy, wet, or dusty conditions. A clean air filter will help the Mini Bike run at peak performance allowing better gas mileage, more power and will protect the engine from the damaging effects of dirt entering the engine.

Air filter removal, inspection and cleaning instructions

1. Locate the air filter assembly (1)
2. Remove the Air filter assembly cover by removing the air filter cover knob (2).
3. Remove the air filter element from the assembly by removing the wing nut (3)
4. Remove the foam element (4) from the paper air filter element (5) and clean foam element with mild soap and water. Rinse and squeeze out excess water and allow to dry .

Note: If foam element (4) is damaged, replace.

5. Inspect the air filter paper element (5) for dirt and damage. If dirty, gently tap element on ground to remove any excess debris. Gently blow out element from the inside with compressed air. If element is too clogged or damaged for continued use, replace the element.
6. Once cleaned or replaced, re-install.

<h3>CAUTION</h3> <p>Clean air filter frequently if Mini Bike is driven in wet, muddy or dusty conditions.</p> <p>Driving in the above conditions without cleaning frequently can plug up the air filter which can cause poor gas mileage, low power and cause damage to the engine.</p>

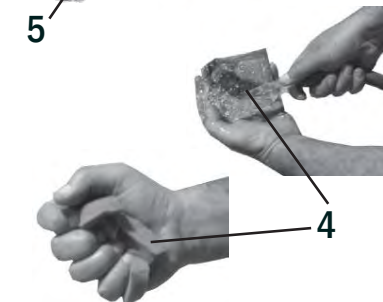
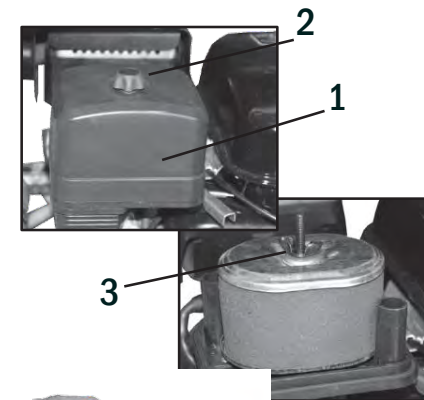

MAINTENANCE CHART

ITEM	First 5 hours of operation	Before each ride	Every 20 hours of operation or 1 month	Every 50 hours or 3 months	Every 100 hours or 6 months
Exhaust pipe nuts and muffler bolts	T	I	T		
Air cleaner element	I		I		
Valve Clearance**					I
Spark Plug			I		R
Fuel Line		I			
Idle speed	I		I		
Condition of throttle and brake cables	I	I			
Engine oil	R	I		R	
Drive Chain	Inspect drive chain before each ride. Clean and lubricate as necessary				
Brakes	I		I		
Brake hose	I		I		
Brake fluid	Inspect brake fluid level before each ride, if low, check brake pads for wear and brake lines and components for leaks. Replace brake fluid every 2 years.				
Tires		I			
Steering	I		I		
Front suspension	I		I		
Rear suspension	I		I		
Chassis nuts and bolts	T	I	T		

** Recommended to be performed by an authorized service center or service center of the owner's choosing.

NOTE: I=INSPECT AND CLEAN,ADJUST,REPLACE OR LUBRICATE AS NECESSARY,

R=REPLACE,T=TIGHTEN

RIDING THE MINI BIKE

STARTING OFF

1. Start and warm up the engine according to the instructions in this manual.
2. Place the side kick stand in the up position.
3. Apply the throttle gradually to start riding. Practice riding Mini Bike on a flat dirt surface that has plenty of room for turning.

⚠ WARNING

Turning the throttle grip to full throttle when starting off could be hazardous.

The Mini Bike could lurch forward causing the front wheels to leave the ground causing loss of control.

Always open the throttle gradually when starting off from a stopped position.

⚠ WARNING

Operating this Mini Bike at excessive speeds could be hazardous.

Riding at excessive speeds increases your chances of losing control of the Mini Bike, which could result in severe injury or death.

Always go at a speed that is proper for the terrain, visibility, operating conditions, operator skill, and operator experience. Always know the terrain before riding.

⚠ WARNING

Removing hands from the handlebars and/or feet from the footrest while operating the Mini Bike could be hazardous.

Removing both or one hand from the handlebars and/or feet from the footrests could result in loss of control of the Mini Bike resulting in severe injury or death.

Always ride with both hands on the handle bars and both feet on the footrests while operating the Mini Bike.

⚠ WARNING

Braking while turning could be hazardous.

Braking while turning could cause the Mini Bike to slide out of control which could result in severe injury or death.

Before making a turn, slow down and release the brake.

RIDING THE MINI BIKE

Load Guidelines

Load guidelines including accessories:

Never exceed the maximum load capability of the Mini Bike. This includes the weight of the rider and any cargo. This Mini Bike is rated at 200 lbs. (91kg).

Do not add any accessory or cargo to the handlebars that could impede vision or make the Mini Bike harder to steer.

Make sure accessories do not get in the way of any controls of the Mini Bike.

After Market parts

After market parts and accessories may be available from other manufactures. Coleman Powersports cannot confirm the quality, safety or suitability of accessories available. When purchasing an accessory, use caution, the handling of the Mini Bike could become affected. Some accessories may make the Mini Bike unsafe to ride. If you have a question about a modification or accessory, contact your dealer or call Coleman Powersports.

WARNING

Riding this Mini Bike with modifications or adding accessories could be hazardous.

Modifications to the Mini Bike, including adding accessories, could adversely affect the handling of the Mini Bike causing an accident which could result in severe injury of death.

Never Modify this Mini Bike in anyway, including adding accessories, unless the modification is a genuine certified modification or accessory approved by the manufacture. Never modify the Mini Bike with improper installation. Make sure to follow all instructions recommended in the certified modification. Use only genuine parts. For questions, contact your dealer.

MAINTENANCE

For maintenance, your mini bike may be maintained by an authorized Coleman Powersports service dealer or a repair shop of your choosing.

Following the proper maintenance procedures and time table for maintenance listed in this manual is important for the safety of the rider and the life span of the Mini Bike. When riding in harsh conditions, such as water, mud and dust, the maintenance procedures should be performed more often.

WARNING

Failing to perform the recommended maintenance on this Mini Bike could be hazardous.

Failing to perform proper maintenance on this Mini Bike could result in an accident

Always perform the recommended maintenance for the Mini Bike as noted in this manual.

WARNING

Performing maintenance and inspection while the engine is running could be hazardous.

Performing maintenance and inspections while the engine is running could result in getting body parts or clothing caught in moving parts, or could result in touching hot items which could result in severe injury.

Shut off engine when performing maintenance and inspection checks, with the exception of checking the engine stop switch and throttle.

CAUTION

Failing to perform recommended maintenance on this Mini Bike could damage the Mini Bike engine and components

Always perform the recommended maintenance on this Mini Bike as listed in this manual.

Maintenance will need to be performed more often if ridden in wet, muddy or dusty conditions.

CAUTION

Failing to use compatible parts with the original replacement parts could damage Mini Bike

Using parts that are of low quality could result in Mini Bike breakdowns and reduce the useful life of the Mini Bike.

Never use parts that are not compatible with the original parts..