

Arles French Bistro Side Chair

Item#: 64277

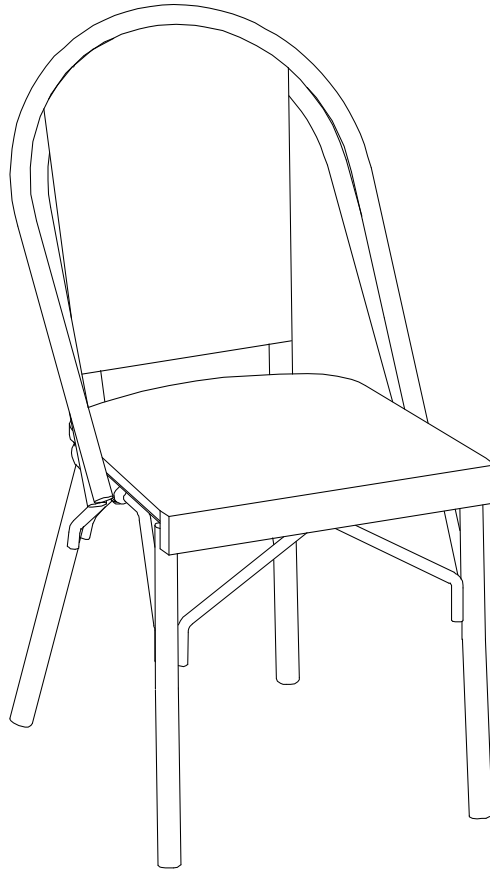

ATTACH YOUR RECEIPT HERE

Keep a copy of your proof of purchase or order confirmation which will be needed if you need to contact us about warranty coverage.

Purchase Date: _____



SAVE THESE INSTRUCTIONS FOR FUTURE REFERENCE.



Questions, problems, missing parts?

Before returning to your retailer, our Florida-based customer service team is available:

Call toll-free

(866) 985-7877

9 a.m. – 9 p.m., EST

Email

cservice@welltraveled.net

Live chat

www.balkenehome.com

9 a.m. – 6 p.m., EST, Monday – Friday



BEFORE YOU BEGIN

Before beginning assembly, make sure all parts are present. Compare parts received with the “Parts List.” If any part is missing or damaged, do NOT attempt to assemble the product. Please read and understand this entire manual before attempting to assemble, operate or install this product. If you have any questions regarding the product, please contact Customer Service.



GENERAL INFORMATION

Your new chair is made from the finest materials available. It should provide many years of enjoyment with minimal care. This chair is intended for outdoor use but as with all products, the materials and finishes will age faster with greater exposure to the weather and sun.

For best results, keep your chair clean and dry. Clean with a soft, damp cloth. If you use furniture covers, always make sure the chair is clean and completely dry before covering, as mold may form in dark, wet places. For best results, remove any cushions and store separately before covering. When seasonally out of use, store this chair in a dry, temperature controlled place to protect its appearance and prolong its useful lifespan. Check the hardware on your chair regularly to make sure it is secure.

The weight limit for this chair is 285 LB /130 KG.

To avoid damaging the chair, do not drag when moving.

SAFETY INFORMATION



WARNING

DO NOT stand or allow children to stand on this chair. Make sure connectors are securely in place. Perform periodic checks to make sure the connectors are secure and adjust if needed.

CAUTION

READ all instructions before beginning assembly. Failure to do so may result in faulty assembly and potential injury. Assemble the item on a soft, non-abrasive surface such as carpet or cardboard to avoid damaging the item.

A

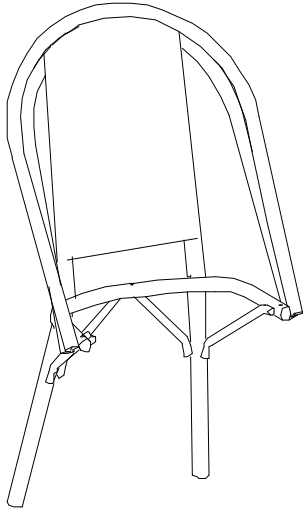

PART	DESCRIPTION	QUANTITY
A	Chair Back	1
B	Seat	1

B

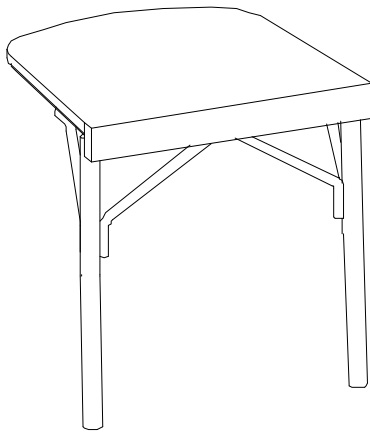

HARDWARE CONTENTS

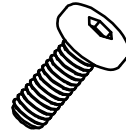

C

M6x40mm Bolt
Qty: 3



D

16mm Washer
Qty: 3



Hex Wrench
Qty: 1



PREPARATION

Before beginning assembly, be sure to empty the contents of the carton and make sure all parts are present. If any parts are missing, please contact Customer Service.

Place all parts on a nonabrasive, level surface for assembly. A countertop or table is ideal.

Estimated Assembly Time: 15 minutes

DO NOT over-tighten hardware. Over-tightening can strip hardware threads.

TIP: Before beginning assembly, place a **Washer D** on each of the 3 **Bolts C**.

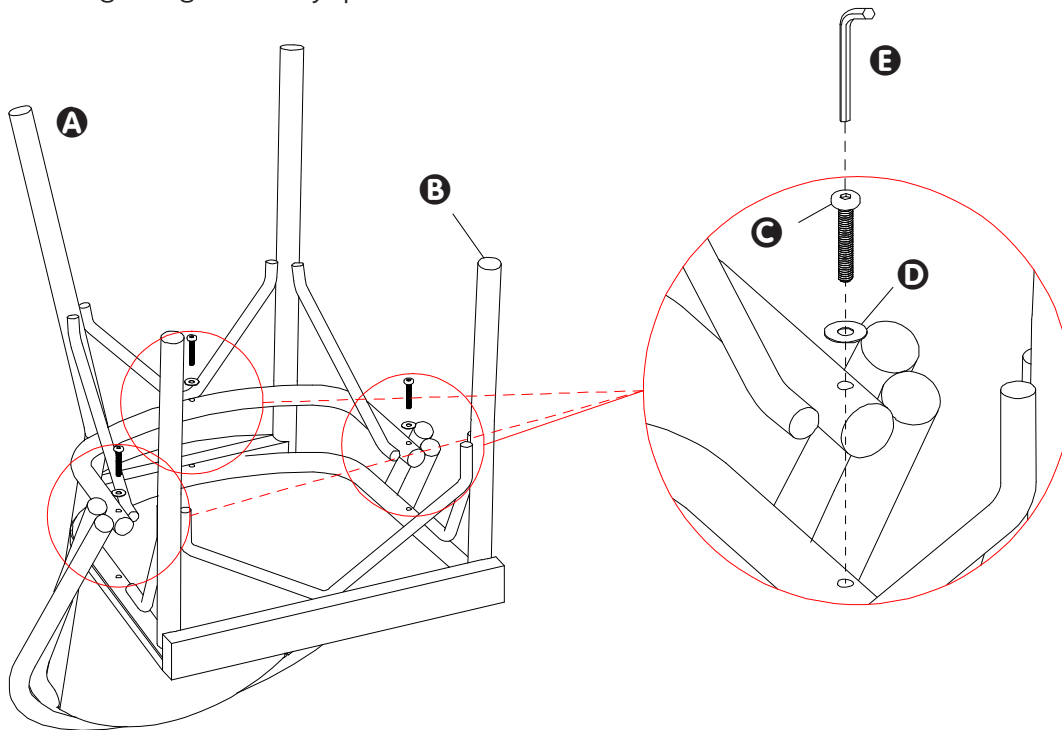

Place the **Seat B** upside-down on a table or counter with the curved portion of the seat facing the edge of the table.

Turn the **Chair Back A** upside-down and align the holes near each end and at the center of the horizontal cross-bar with the holes in the U-shaped seat support of the **Seat**, as shown.

Insert a **Bolt C** with **Washer D** into each of the aligned sets of holes. Tighten gently but firmly with the **Hex Wrench**. **DO NOT over-tighten hardware. Over-tightening can strip the hardware threads.**

When all hardware is securely installed, carefully turn the chair right-side up.

Your **Arles Bistro Chair** is ready for use!

Hardware Used:

- Bolt (M6x40) x3
- Washer (16mm) x3

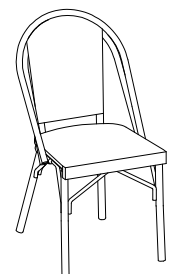

BALKENE —HOME—



LIMITED WARRANTY

Customers in the Contiguous US

With proof of purchase from an authorized retailer, this product is warranted for a period of 1 year from original purchase date against defects in materials and workmanship under normal use. This warranty does NOT cover normal wear/weathering, exposure to water, freezing temperatures, oils, fluids, or chemicals OR use in a commercial context if the unit is not designated as a commercial model. At Balkene Home's sole discretion, products under warranty will be repaired and/or replaced at no charge to the customer. Returns sent back to Well Traveled Living must be sent via prepaid freight in the original retail packaging.

For warranty service, contact Balkene Home at the address, phone numbers or website and email listed in this owner's manual. Be sure to have your sales receipt, date of purchase and catalogue/model numbers available when calling. All warranty service will be coordinated by Balkene Home's Amelia Island, Florida service center. This warranty is extended only to the original owner. Proof of purchase will be required before warranty service is rendered. The sales receipt is the only valid proof of purchase. This warranty only covers failures due to defects in materials or workmanship which occur during normal use. Failures and/or damage which result from accident, negligence, misuse, abuse, neglect, mishandling, alteration or modification, failure to maintain, improper assembly or maintenance, service by unauthorized agency or use of unauthorized components or damage that is attributable to acts of God are NOT covered.

This limited warranty gives you specific legal rights and you may also have other rights which vary from jurisdiction to jurisdiction. The provisions of the United Nations Convention on Contracts for the Sales of Goods shall not apply to this limited warranty or the sale of products covered by this limited warranty.

- THERE ARE NO EXPRESS WARRANTIES EXCEPT AS LISTED.
- PURCHASER ASSUMES ALL RISKS IN THE ASSEMBLY AND OPERATION OF THIS UNIT.
- FAILURE TO FOLLOW WARNINGS AND OPERATIONAL INSTRUCTIONS CONTAINED IN THIS MANUAL CAN RESULT IN SEVERE PROPERTY DAMAGE AND/OR PERSONAL INJURY.
- IN NO EVENT WILL BALKENE HOME/WELL TRAVELED LIVING, OR ITS DIRECTORS, OFFICERS OR AGENTS BE LIABLE TO THE PURCHASER OR ANY THIRD PARTY, WHETHER IN CONTRACT, IN TORT, OR ON ANY OTHER BASIS, FOR ANY INDIRECT, SPECIAL, PUNITIVE, EXEMPLARY, CONSEQUENTIAL, OR INCIDENTAL LOSS, COST, OR DAMAGE ARISING OUT OF OR IN CONNECTION WITH THE SALE, MAINTENANCE, USE, OR INABILITY TO USE THE PRODUCT, EVEN IF BALKENE HOME/WELL TRAVELED LIVING OR ITS DIRECTORS, OFFICERS OR AGENTS HAVE BEEN ADVISED OF THE POSSIBILITY OF SUCH LOSSES, COSTS OR DAMAGES, OR IF SUCH LOSSES, COSTS, OR DAMAGES ARE FORESEEABLE. IN NO EVENT WILL BALKENE HOME/WELL TRAVELED LIVING, OR ITS OFFICERS, DIRECTORS, OR AGENTS BE LIABLE FOR ANY DIRECT LOSSES, COSTS OR DAMAGES THAT EXCEED THE PURCHASE PRICE OF THE PRODUCT.
- SOME JURISDICTIONS DO NOT ALLOW THE EXCLUSION OR LIMITATION OF INCIDENTAL OR CONSEQUENTIAL DAMAGES, SO THE ABOVE LIMITATION OR EXCLUSION MAY NOT APPLY TO THE PURCHASER.

EXTEND YOUR WARRANTY

When you purchase a Fire Sense or Balkene Home product from any authorized retailer, you'll have peace of mind in knowing that it comes with a one-year warranty. Extend your warranty for *an additional year* when you review your item at balkenehome.com within 365 days of purchase.



Important Notice

Do NOT return to place of purchase—for customer service and warranty issues:

Call toll-free (866) 985-7877 9 a.m. – 9 p.m., EST
Email cservice@welltraveled.net
Live chat balkenehome.com 9 a.m. – 6 p.m., EST, Monday – Friday

Distributed by:
Well Traveled Living
716 S 8th Street, Amelia Island, FL 32034
balkenehome.com
cservice@welltraveled.net
(866) 985-7877