

Outdoor Portable LP Gas Griddle

Model No. GGC2030M

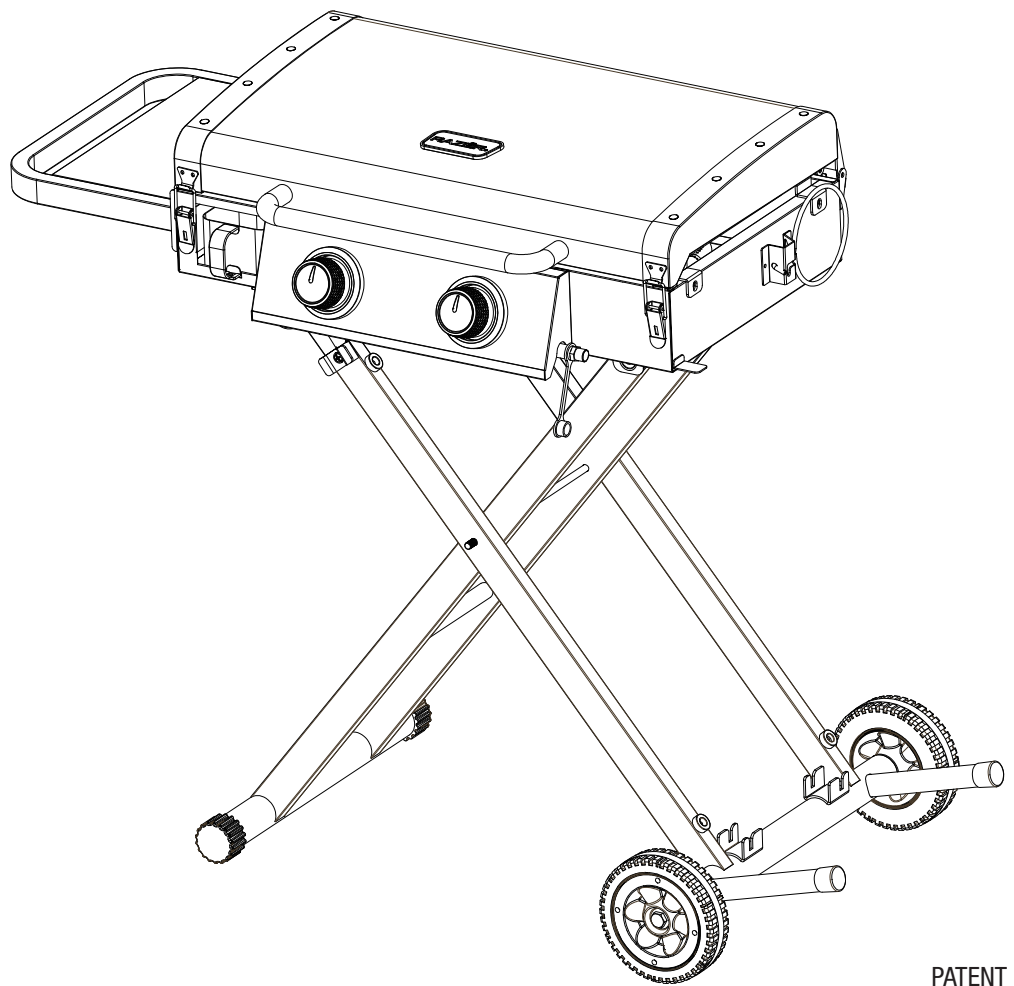

PATENT PENDING



WARNING

FOR YOUR SAFETY:

DO NOT LEAVE THIS APPLIANCE UNATTENDED WHILE IN USE, ESPECIALLY COOKING THE FATTY MEAT AND CLOSE THE LID TOO LONG TIME.



WARNING

FOR YOUR SAFETY:

For Outdoor Use Only
(outside any enclosure)



DANGER

If you smell gas -

- Shut off gas to appliance.
- Extinguish any open flame.
- Open Lid.
- If odor continues, keep away from the appliance and immediately call your fire department.

Failure to follow these instructions could result in fire or explosion which could cause property damage, personal injury or death.



DANGER

- Never operate this appliance unattended.
- Never operate this appliance within 10 ft (3.0 m) of any structure, combustible material or other gas cylinder.
- Never operate this appliance with 25 ft (7.5 m) of any flammable liquid.
- Do not fill cooking vessel beyond maximum fill line.
- Never allow oil or grease to get hotter than 400°F or 200°C. If the temperature exceeds 400°F (200°C) or if oil begins to smoke, immediately turn the burner or gas supply OFF.
- Heated liquids remain at scalding temperatures long after the cooking process. Never touch cooking appliance until liquids have cooled to 115°F (45°C) or less.
- If a fire should occur, keep away from the appliance and immediately call your fire department. Do not attempt to extinguish an oil or a grease fire with water.

Failure to follow these instructions could result in fire, explosion or burn hazard which could cause property damage, personal injury or death.



WARNING

FOR YOUR SAFETY:

1. Do NOT store or use gasoline or other flammable liquids or vapors in the vicinity of this or any other appliance.
2. An LP cylinder not connected for use shall not be stored in the vicinity of this or any other appliance.
3. Improper installation, adjustment, alteration, service or maintenance can cause injury or property damage.
4. Read the installation, operation, and maintenance instructions thoroughly before installing or servicing this equipment.

IMPORTANT

After each use, always season your griddle per "Seasoning Griddle" section.

Table of Contents

Important Safeguards	Page 2
Expanded View & Hardware	4
Assembly Instructions	5
Griddle Storage & Transporting	7
Installing LP Gas Tank	10
Operating Instructions	10
Cleaning and Care	11
Product Registration	12
Replacement Parts	12
Limited Warranty	12
Troubleshooting	13

The use and installation must conform with local codes or, in the absence of local codes, with either the *National Fuel Gas Code, ANSI Z223.1/NFPA 54, Storage and Handling of Liquefied Petroleum Gases, ANSI/NFPA 58, Natural Gas and Propane Installation Code, CSA B149.1, or Propane Storage and Handling Code, B149.2, or the Standard for Recreational Vehicles, ANSI A 119.2/NFPA 1192, and CSA Z240 RV Series, as applicable.*

THIS INSTRUCTION BOOKLET CONTAINS IMPORTANT SAFETY INFORMATION. PLEASE READ AND KEEP FOR FUTURE REFERENCE.

If you are assembling this unit for someone else, give this manual to them to read and save for future reference.

⚠ WARNING: This product can expose you to chemicals including carbon monoxide, soot, lead and lead components which are known to the State of California to cause cancer and birth defects or other reproductive harm. Wash your hands after handling this product. For more information go to www.P65Warnings.ca.gov.



Manufactured in China for: RevoAce Inc. Limited
Hong Kong, China • 1.800.694.0013 • service@revoace.com
8:00 am to 4:00 pm central time, Monday to Friday.
© RevoAce Inc. Limited
Razor® is a registered trademark of Mr. Bar-B-Q Products LLC. Used with permission.

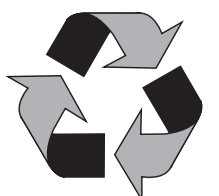

Made from 75% Bagasse
(environmentally friendly sugar
cane pulp by-product)

Important Safeguards - LP Gas

- ▲ **DANGER:** Failure to follow the dangers, warnings and cautions in this manual may result in serious bodily injury or death, or in a fire or an explosion causing damage to property.
-
- ▲ **WARNINGS:**
 - ▲ This griddle is for outdoor use only, and should not be used in a building, garage or any other enclosed area.
 - ▲ Do NOT operate, light or use this appliance within ten feet (3.05 m) of walls, structures or buildings.
 - ▲ For residential use only. This griddle is NOT for commercial use.
 - ▲ This griddle is not intended for and should never be used as a heater. TOXIC fumes can accumulate and cause asphyxiation.
 - ▲ This is NOT a tabletop griddle. Therefore, do NOT operate this griddle on any type of tabletop surface.
 - ▲ This griddle is safety certified for use in the United States and/or Canada only. Do NOT modify for use in any other location. Modification will result in a safety hazard and will void your warranty.
 - ▲ This griddle is for use with liquid propane (LP) gas only. The conversion to or attempted use of natural gas in this LP gas griddle is dangerous, may cause bodily harm and will void your warranty.
 - ▲ Do NOT over heat this griddle as this will damage the griddle and could cause a fire or an explosion which can cause death, serious bodily injury or damage to property.
 - ▲ LP gas characteristics:
 - a. LP gas is flammable and hazardous if handled improperly. Become aware of the characteristics before using any LP gas product.
 - b. LP gas is explosive under pressure, heavier than air, and settles and pools in low areas.
 - c. LP gas in its natural state has no odor. For your safety, an odorant is added that smells like rotten cabbage.
 - d. Contact with LP gas can cause freeze burns to skin.
 - ▲ Apartment dwellers: Check with management to learn the requirements and fire codes for using a LP gas griddle in your apartment complex. If allowed, use outside on the ground floor with a ten foot (3.05 m) clearance from any structure. Do NOT use on or under balconies.
 - ▲ LP gas cylinder needed to operate. Only cylinders marked "propane" may be used.
 - ▲ The LP gas cylinder must be constructed and marked in accordance with the *Specifications for LP-gas Cylinders* of the U.S. Department of Transportation (D.O.T.), *Cylinders, Spheres and Tubes for the Transportation of Dangerous Goods*; or the National Standard of Canada, *CAN/CSA-B339*.
 - ▲ LP gas cylinder must be arranged for vapor withdrawal.
 - ▲ Dented or rusted LP gas cylinders may be hazardous and should be checked by your LP gas supplier prior to use.
 - ▲ The LP gas cylinder should not be dropped or handled roughly.
 - ▲ LP gas cylinders must be stored outdoors out of the reach of children and must not be stored in a building, garage or any other enclosed area. Your cylinder must never be stored where temperatures can reach over 125°F.
 - ▲ Do NOT insert any tool or foreign object into the valve outlet or safety relief valve. You may damage the valve and cause a leak. Leaking propane may result in an explosion, fire, severe personal injury or death.
 - ▲ Do NOT block holes in sides, bottom or back of griddle.
 - ▲ Never keep an LP gas cylinder in a hot car or trunk. Heat will cause the gas pressure to increase, which may open the relief valve and allow gas to escape.
 - ▲ Do NOT store a spare LP gas tank under or within 25 feet (7.62 m) of this appliance.
 - ▲ Never attempt to attach this griddle to the self-contained LP gas system of a camper trailer, motor home or house.
 - ▲ The use of alcohol, prescription or non-prescription drugs may impair the consumer's ability to properly assemble or safely operate the appliance.
 - ▲ Strong odors, colds, sinus congestion, etc. may prevent the detection of propane. Use caution and common sense when testing for leaks.
 - ▲ NEVER use lighter fluid, lava rocks, gasoline, kerosene or alcohol with this product.
 - ▲ Your griddle has been checked at all factory connections for leaks. Recheck all connections as described in the "Operating Instructions" section of the manual, as shipping can loosen connections.
 - ▲ Check for leaks even if your unit was assembled for you by someone else.
 - ▲ Do NOT operate if a gas leak is present. Gas leaks may cause a fire or explosion.
 - ▲ You must follow all instructions in the "Checking for Leaks" section before operating. To prevent a fire or explosion hazard when testing for a leak:
 - a. Always perform a leak test before lighting the griddle and each time the cylinder is connected for use.
 - b. No smoking. Do NOT use or permit sources of ignition in the area while conducting a leak test.
 - c. Conduct the leak test outdoors in a well-ventilated area.
 - d. Do NOT use matches, lighters, or a flame to check for leaks.
 - e. The use of alcohol, prescription or non-prescription drugs may impair the consumer's ability to properly assemble or safely operate the appliance.
 - f. Strong odors, colds, sinus congestion, etc. may prevent the detection of propane. Use caution and common sense when testing for leaks.
 - g. Do NOT use griddle until any and all leaks are corrected. If you are unable to stop a leak, disconnect the LP gas supply. Call a gas appliance serviceman or your local LP gas supplier.
 - ▲ Do NOT store or use gasoline or other flammable liquids or vapors within 25 feet (7.62 m) of this appliance.
 - ▲ Do NOT use in an explosive atmosphere. Keep griddle area clear and free from combustible materials, gasoline and other flammable vapors and liquids.
 - ▲ Minimum clearance from sides and back of unit to combustible construction is 21 inches (53 cm). Do NOT use this appliance under any type of overhang or roof.
 - ▲ It is essential to keep the griddle's regulator and valve assembly, burners and circulating air passages clean.
 - ▲ Inspect griddle before each use.
 - ▲ Do NOT alter griddle in any manner. Any alteration will void your warranty.
 - ▲ Do NOT use the griddle unless it is COMPLETELY assembled and all parts are securely fastened and tightened.
 - ▲ This griddle should be thoroughly cleaned and inspected on a regular basis.
 - ▲ Clean and inspect the hose before each use of the appliance. If there is evidence of abrasion, wear, cuts or leaks, the hose must be replaced prior to operation.
 - ▲ Use only the pressure regulator provided. Use only the replacement pressure regulator specified by RevoAce Inc. Limited
 - ▲ Do NOT attempt to repair or alter the pressure regulator for any assumed defect. Any modification to this assembly will void your warranty and create the risk of a gas leak and fire. Use only authorized replacement parts supplied by manufacturer.
 - ▲ Use only RevoAce Inc. Limited factory-authorized parts. The use of any part that is not factory-authorized can be dangerous and will void your warranty.
 - ▲ Do NOT operate this appliance without reading "Operating Instructions" in this manual.
 - ▲ Do NOT touch metal parts of griddle until they have completely cooled to avoid burns, unless you are wearing protective gear (pot holders, gloves, BBQ mitts, etc.).
 - ▲ Do NOT install or use in or on boats or recreational vehicles (RV).
 - ▲ Do NOT use griddle in a vehicle trunk, station wagon, mini-van or sport utility vehicle (SUV).

- ⚠ When cooking, fire extinguishing materials should be readily accessible. In the event of an oil/grease fire, do NOT attempt to extinguish with water. Use type BC or ABC dry chemical fire extinguisher or smother with dirt, sand or baking soda.
- ⚠ Move gas hoses as far away as possible from hot surfaces and dripping hot grease.
- ⚠ Do NOT use griddle in high winds.
- ⚠ Never lean over the griddle when lighting.
- ⚠ Do NOT leave a lit griddle unattended. Keep children and pets away from griddle at all times.
- ⚠ Do NOT leave griddle unattended while preheating or burning off food residue on high. If griddle has not been cleaned, a grease fire can occur that may damage the product.
- ⚠ Do NOT place empty cooking vessels on the appliance while in operation.
- ⚠ Use caution when placing anything on the griddle while the appliance is in operation.
- ⚠ Do NOT attempt to move griddle when in use. Allow the griddle to cool before moving or storing.
- ⚠ LP gas cylinder must be properly disconnected and removed prior to moving this griddle.
- ⚠ Storage of griddle indoors is permissible only if the cylinder is disconnected, removed from the griddle and properly stored outdoors.
- ⚠ Do NOT attempt to disconnect the gas regulator from the cylinder or any gas fitting while the griddle is in use.
- ⚠ Disconnect LP gas tank when not in use.
- ⚠ Always place your griddle on a hard, non-combustible, level surface. An asphalt or blacktop surface may not be acceptable for this purpose.
- ⚠ Do NOT use directly on wooden decks.
- ⚠ Keep all electrical cords away from a hot griddle.
- ⚠ After a period of storage and/or non-use, check for leaks, burner obstructions and inspect for any abrasion, wear or cuts to the hose.
- ⚠ Failure to not wait five minutes to allow the gas to clear if the griddle does not light, may result in an explosive flame-up.
- ⚠ Never operate griddle without griddle surface installed.
- ⚠ Always use a meat thermometer to ensure food is cooked to a safe temperature.
- ⚠ Use protective gloves when assembling this product.
- ⚠ Do NOT force parts together as this can result in personal injury or damage to the product.
- ⚠ Never cover entire cooking area with aluminum foil. Laying the foil on the grates can restrict the intended air flow inside the grill, create barriers to the proper flow of grease to the catch pan, which sets the stage for lots of it to build up on the bottom tray, which in turn, builds the potential for grease fires and flare ups.
- ⚠ Deaths, serious injury or damage to property may occur if the above is not followed exactly.
- ⚠ Place dust cap on cylinder valve outlet whenever the cylinder is not in use. Only install the type of dust cap on the cylinder valve outlet that is provided with the cylinder valve. Other types of caps or plugs may result in leakage of propane.
- ⚠ Do NOT store a spare LP gas cylinder under or near this appliance.
- ⚠ Never fill the cylinder beyond 80 percent full.
- ⚠ If the above is not followed exactly, a fire causing death or serious injury may occur.

Parts List

1	Lid*	G2030-010
2	Lid Handle*	G2030-020
3	Logo*	B0109-BRA
4	Griddle Surface*	G2030-030
5	Griddle Body Assembly*	G2030-040
6	Left Burner Assembly*	G2030-050
7	Right Burner Assembly*	G2030-060
8	Control Knob Bezel (2)*	G1143-090
9	Control Knob (2)	G0850-G23
10	Grease Cup	G1860-060
11	LP Gas Tank Support*	G2030-070
12	Side Shelf*	G2030-080
13	Regulator	G2030-090
14	Slide*	G2030-100
15	Left Leg Assembly*	G2030-110
16	Right Leg Assembly*	G2030-120
17	Foot A (2)*	B003-05D
18	Wheel Axle (2)	G2030-130
19	Wheel (2)	B003-02E
20	Foot B (2)*	B003-05B
21	Safety Latch*	
22	Lock A (2)*	B0107-E05
23	Lock B (2)*	B0107-I09

* Pre-assembled

Expanded View

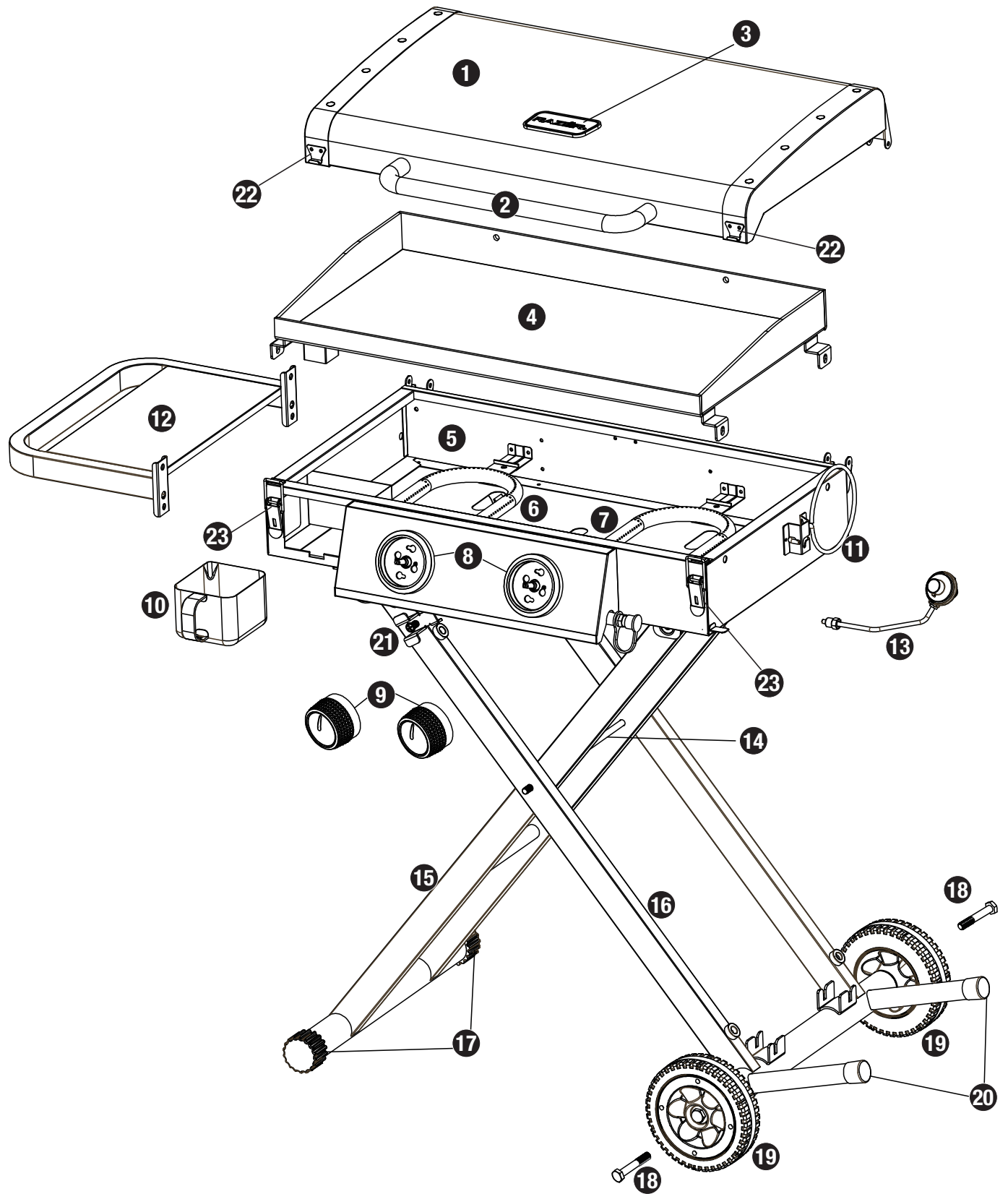

Assembly Instructions

1

DO NOT RETURN TO PLACE OF PURCHASE.

For assistance, call 1.800.694.0013 toll-free. Please have your owner's manual and model number available for reference.

Note: The model number can be found on the back of the griddle.

Assembly Tips:

1. Select an area where you will assemble this product. To protect components, choose a smooth surface that's free of cracks or openings.
2. Spread out all parts.
3. Tighten all hardware connections by hand first. Then, before completing each step, go back and fully tighten all hardware. Be careful not to over-tighten. That could damage surfaces or strip threads.
4. For best results, complete each step in the order presented.

After assembly you will need:

- (1) Leak Detection Solution (instructions on how to make solution are included in "Operating Instructions" section).
- (1) 14.1 oz or (1) 16.4 oz LP gas tank (not included).

Typical assembly is approximately 10 minutes.

2

Attach Wheels

Note: The wrench is required (included).

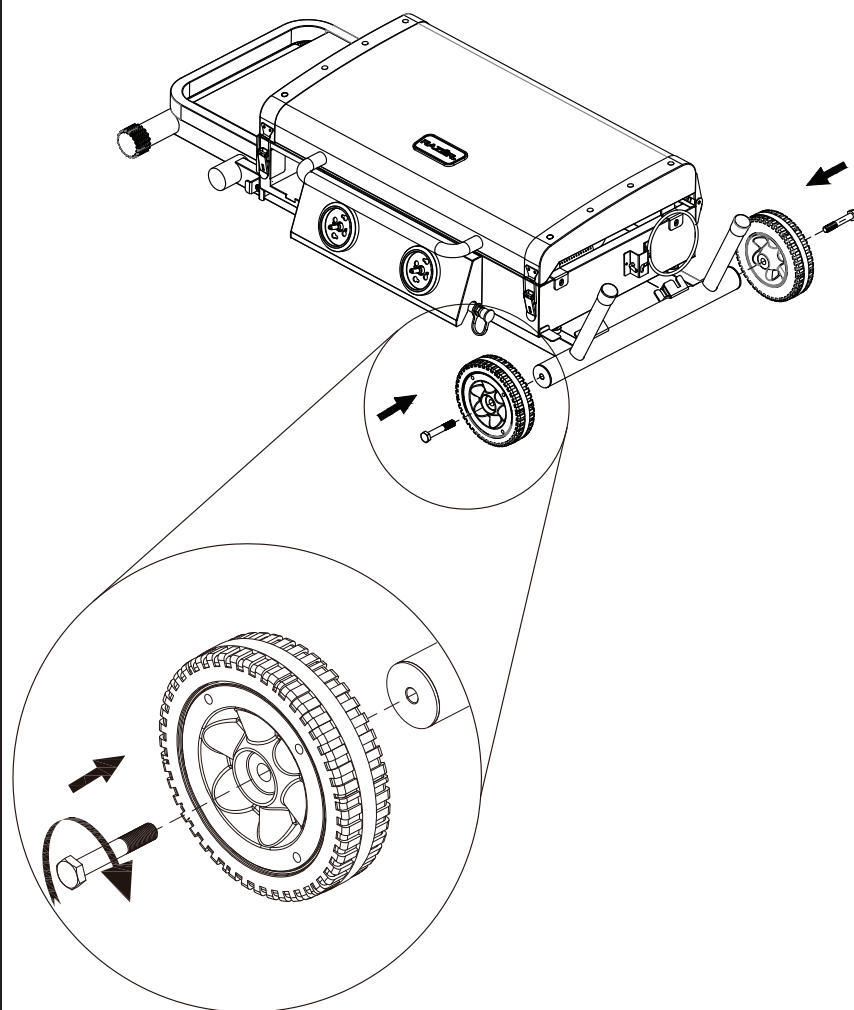

3

Unlock Safety Latch

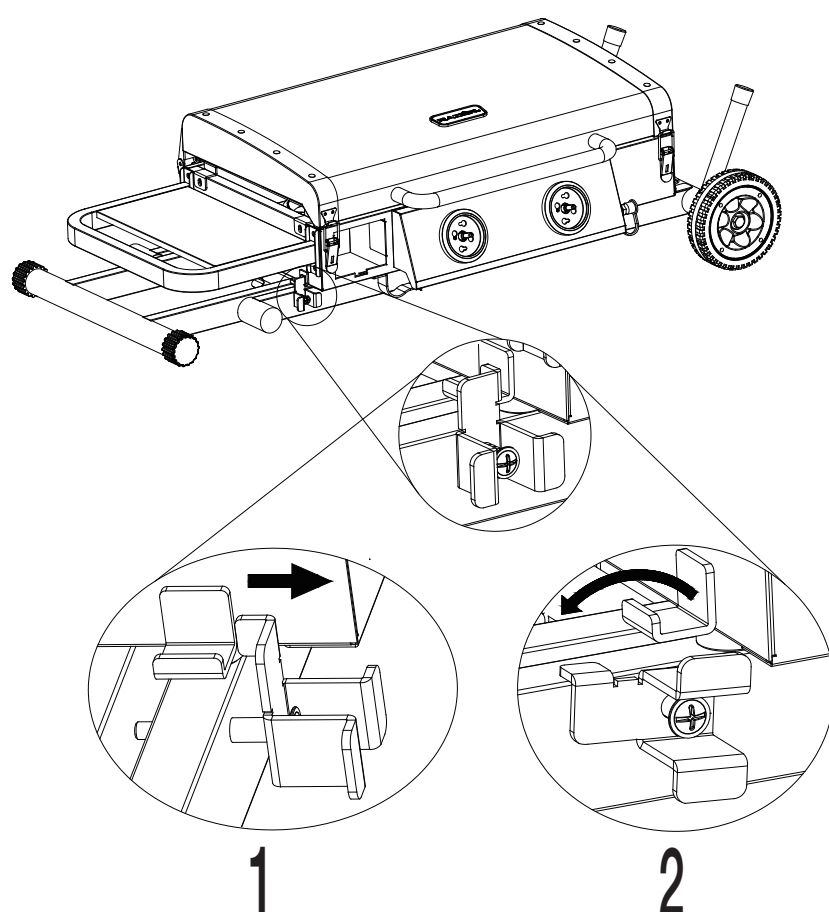

4

Unfold Legs

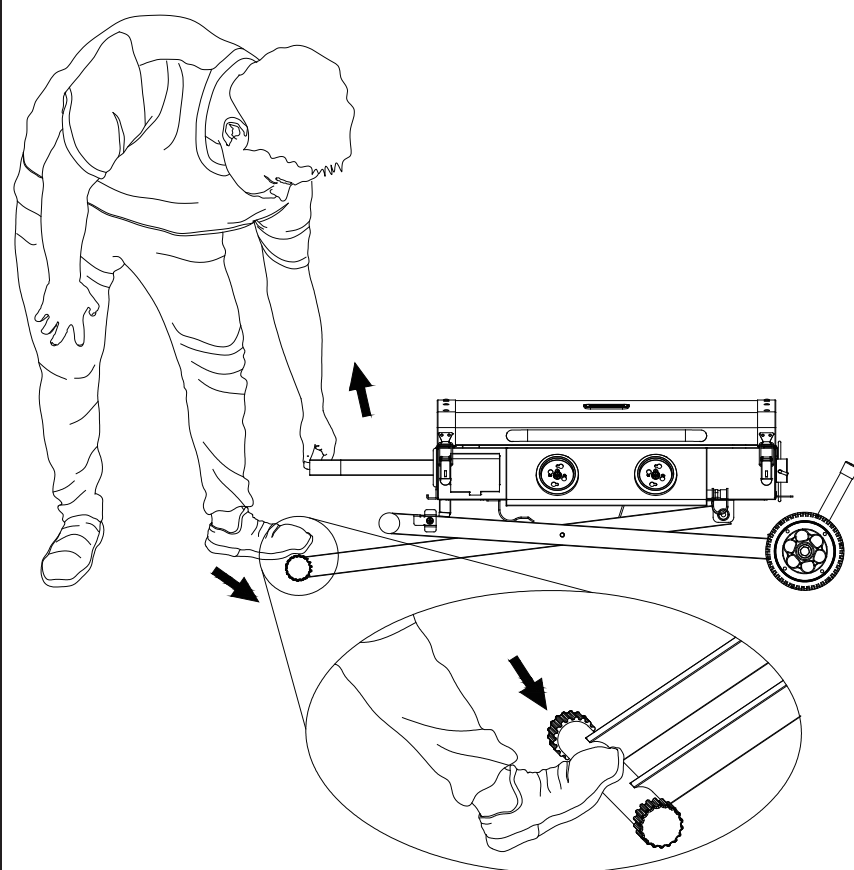

Assembly Instructions (continued)

5

Lock Right Leg

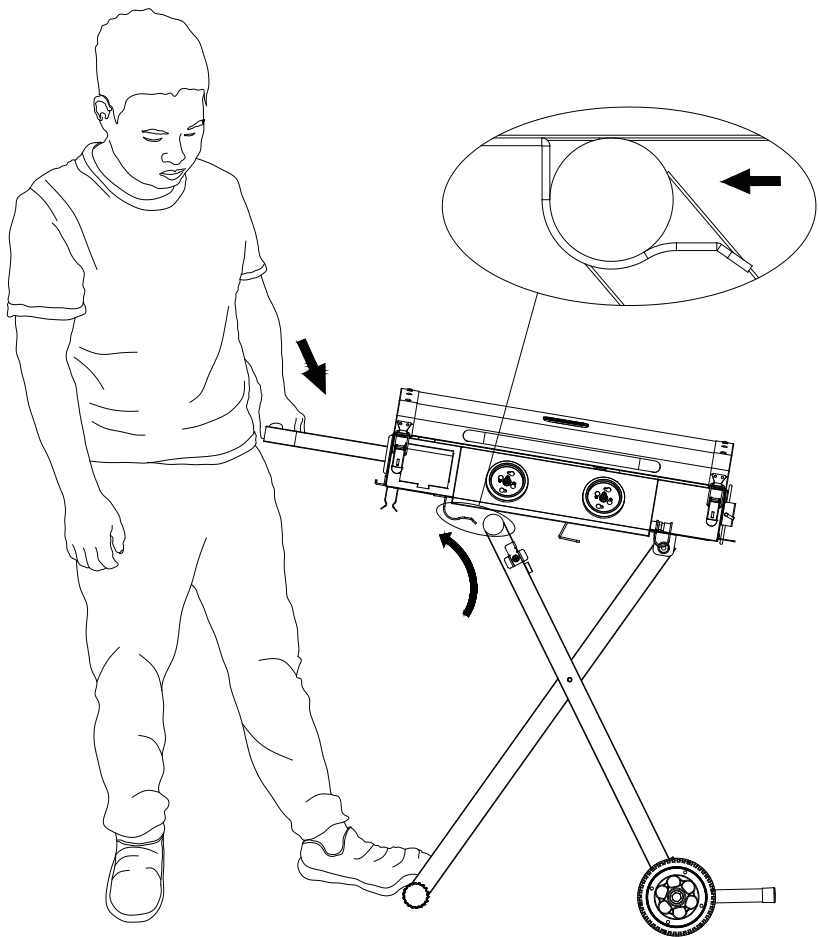

6

Attach Control Knobs and Grease Cup

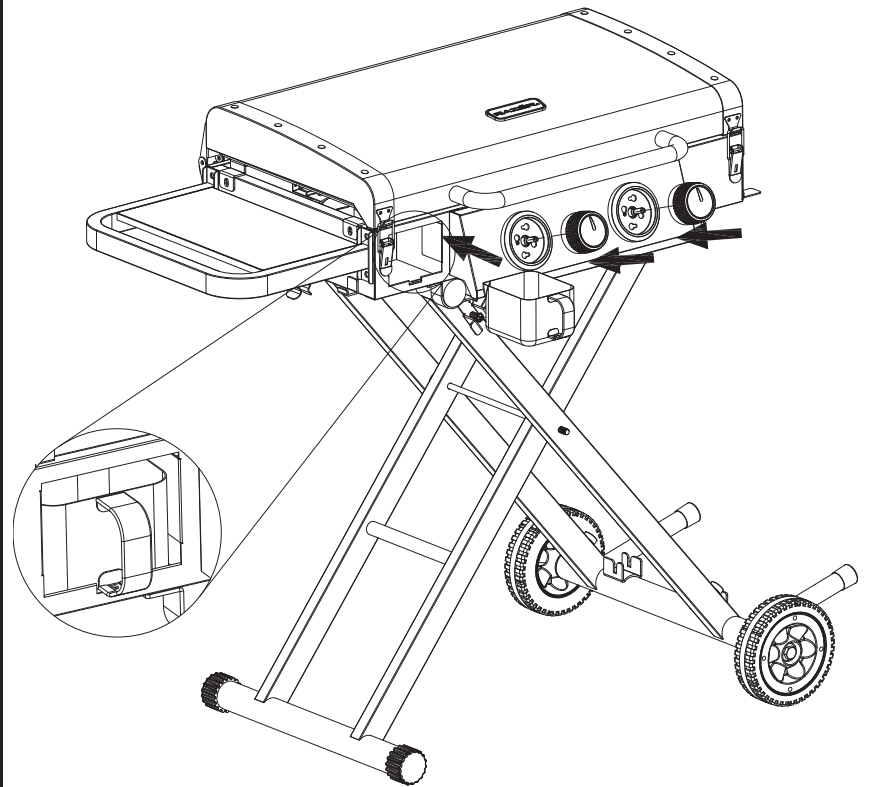

7

Attach Regulator (1lb LP tank is not included)

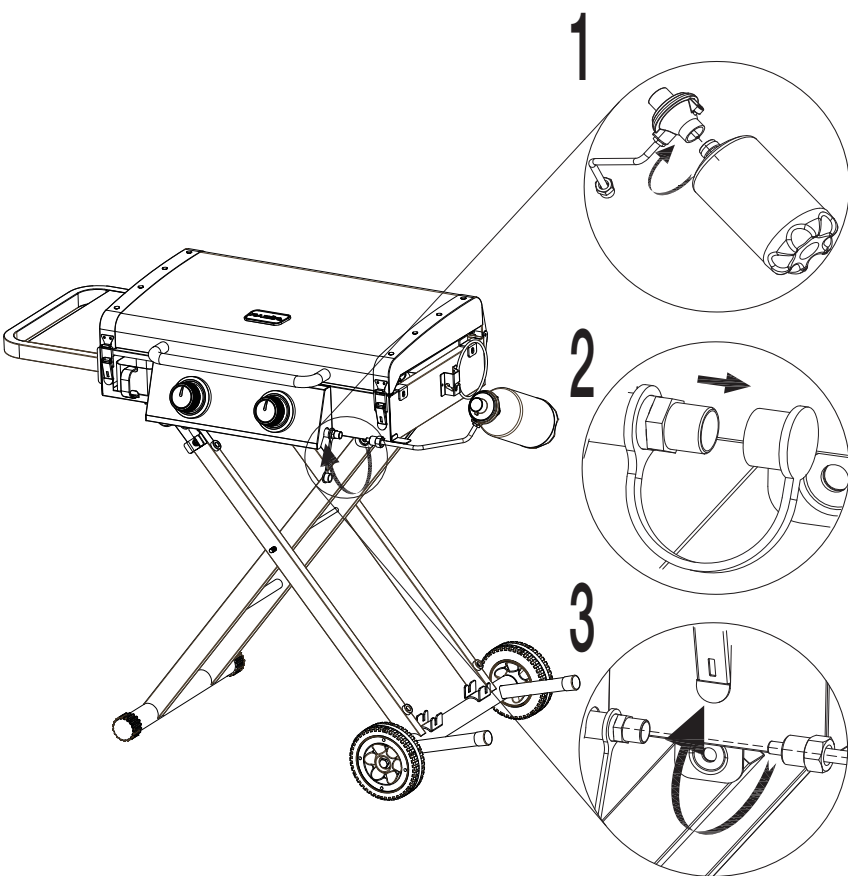

8

Secure LP Gas Tank

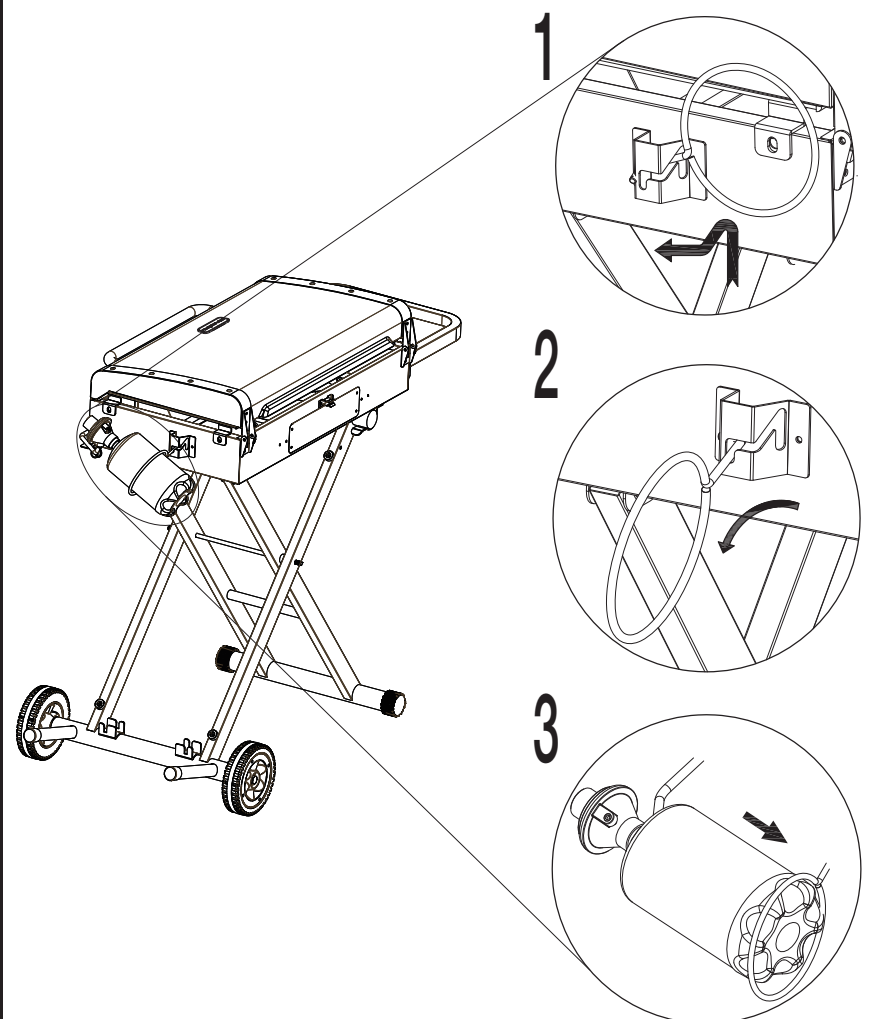

Griddle Storage & Transporting

1

Remove Regulator

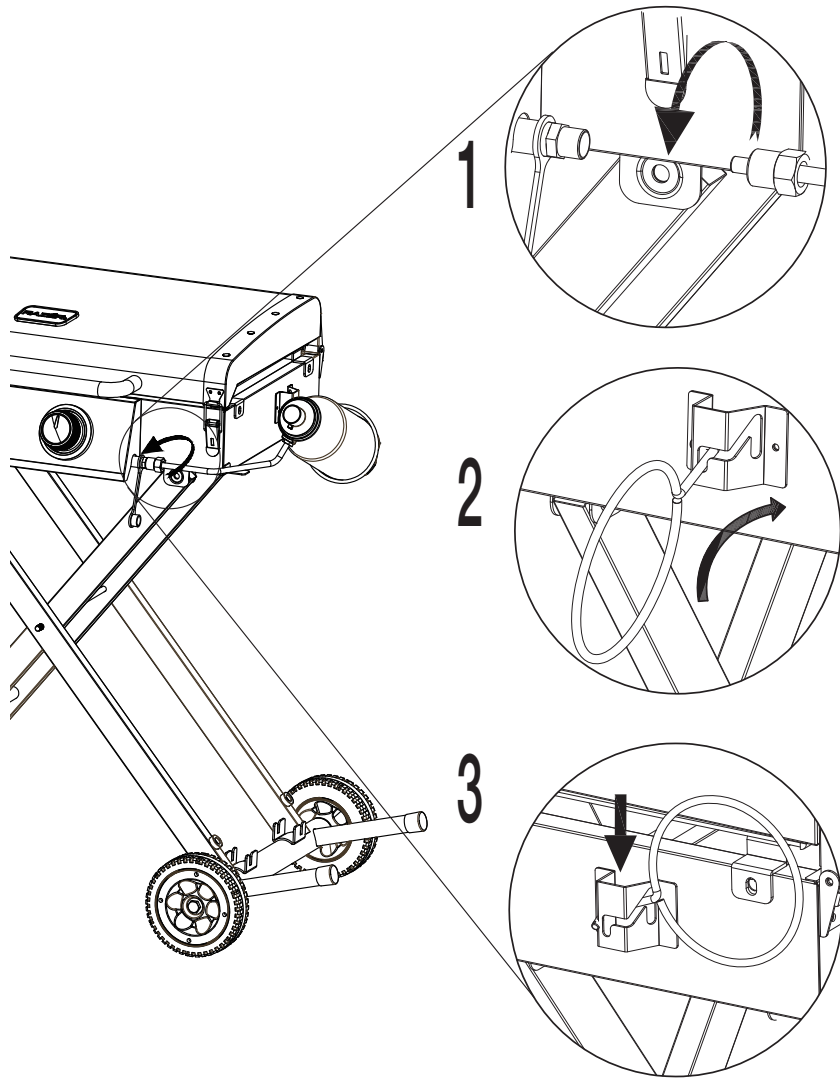

2

Remove LP Gas Tank and Attach Regulator

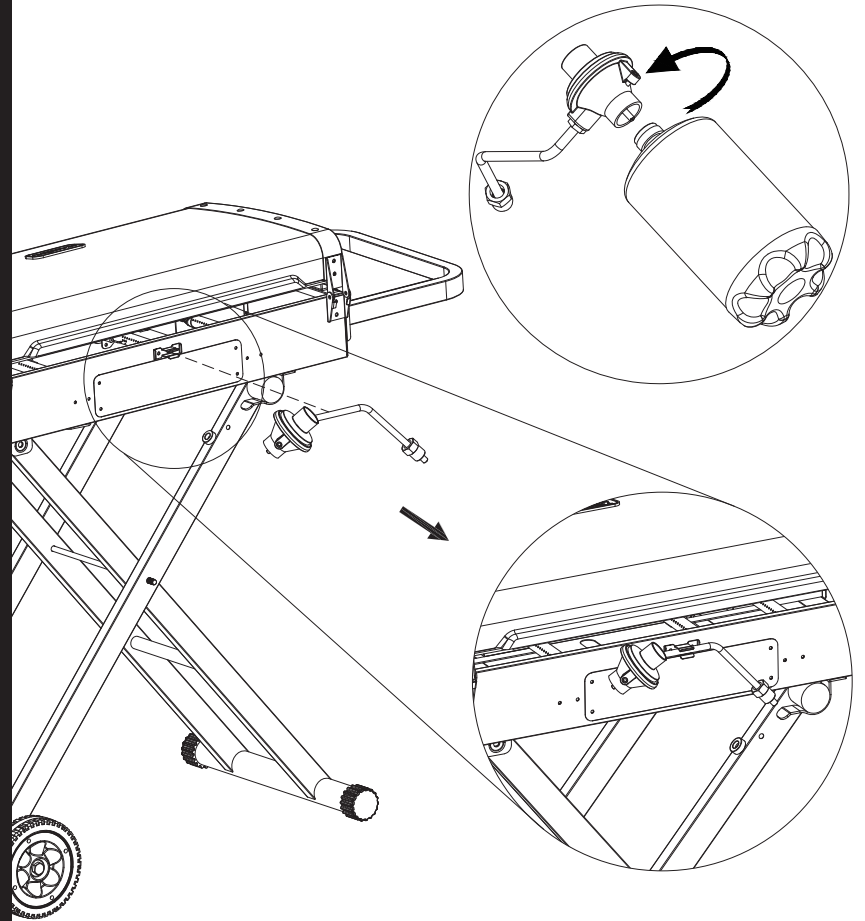

3

Fold Upper LP Gas Tank Support

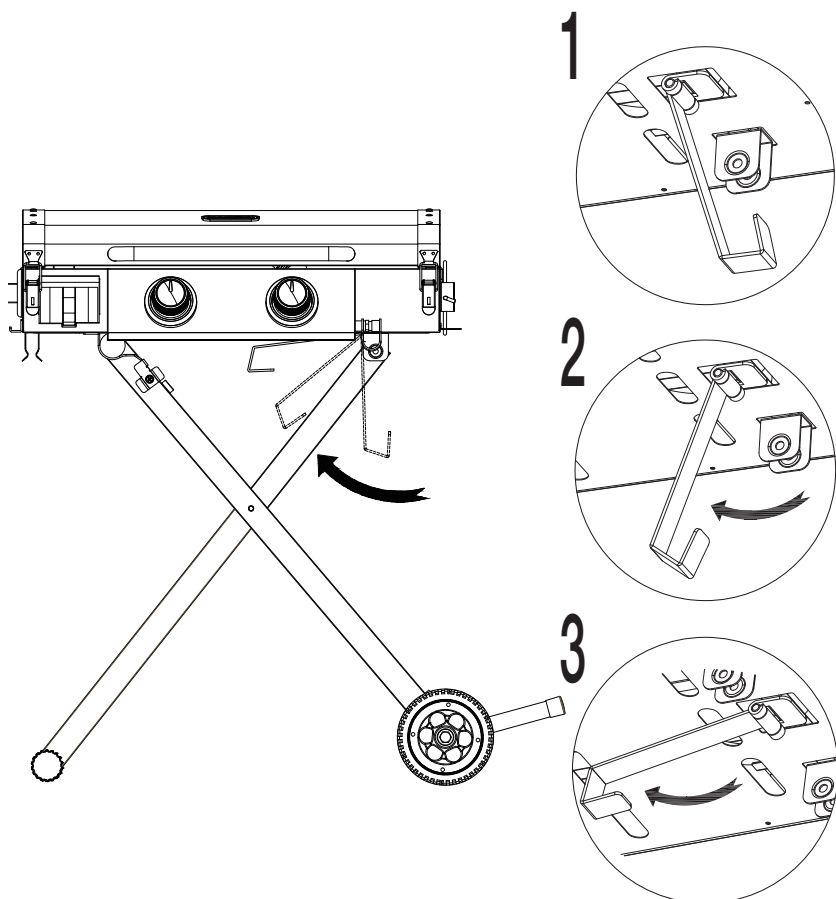

4

Fold Griddle

Note: Make sure the grease cup is empty before folding the griddle.

Note: The safety latch must be unlock before folding the griddle.

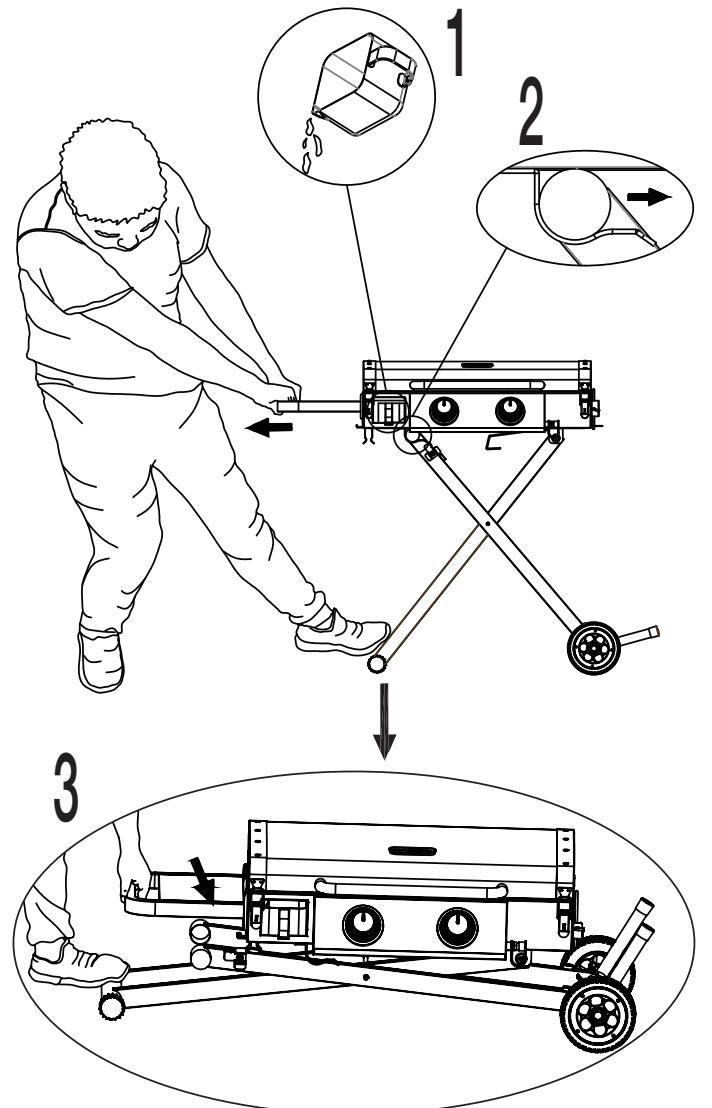

Griddle Storage & Transporting (Continued)

5

Lock Safety Latch

Note: The safety latch must be locked after folding the griddle.

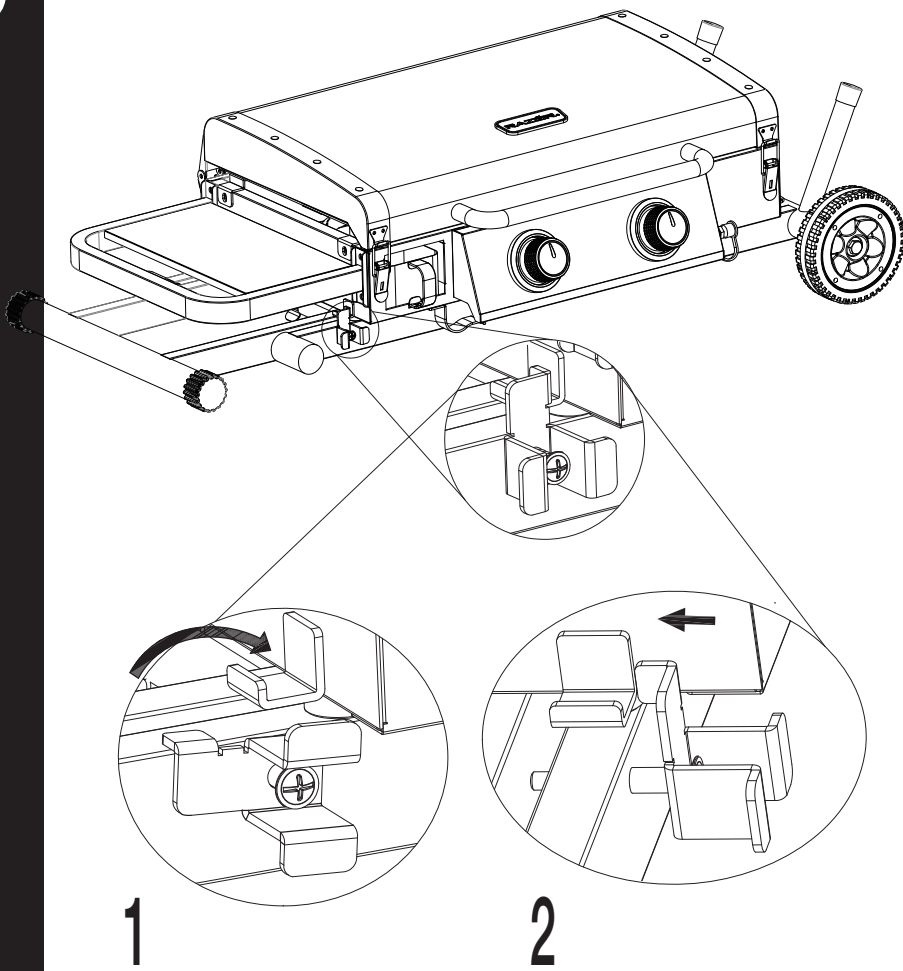

1

2

6

Lock Lid and Unlock Lid

Locking Lid

Note: Lid must be locked before transporting grill.

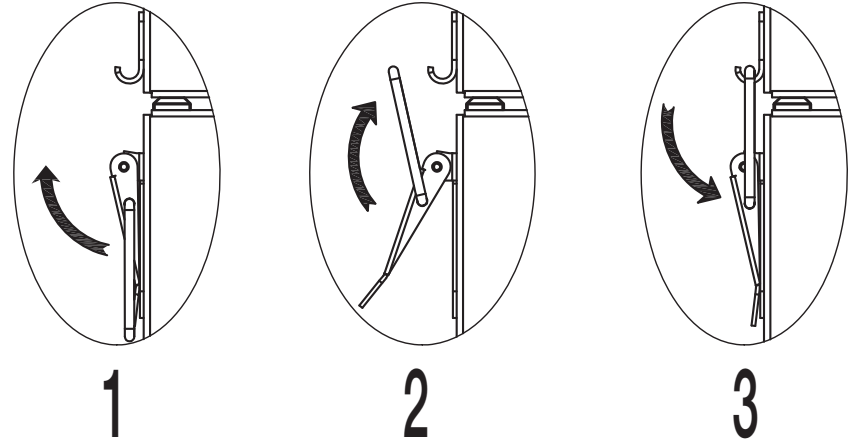

1

2

3

Unlocking Lid

Note: Always unlock and open lid before lighting grill.

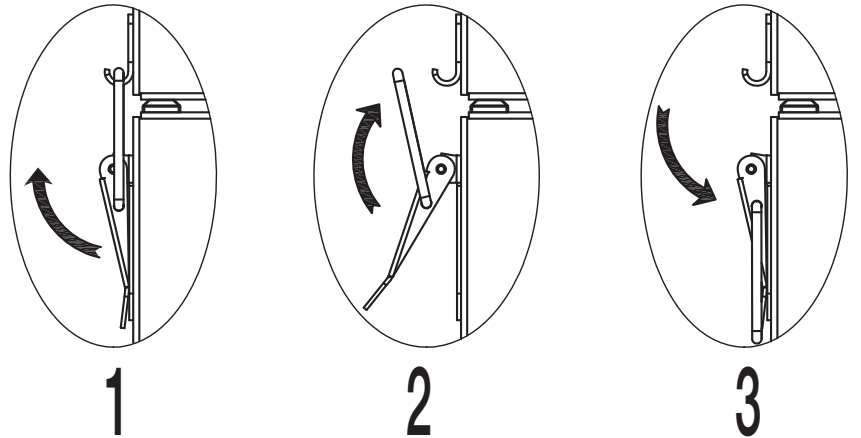

1

2

3

Note: The cart can't be removed from the griddle.

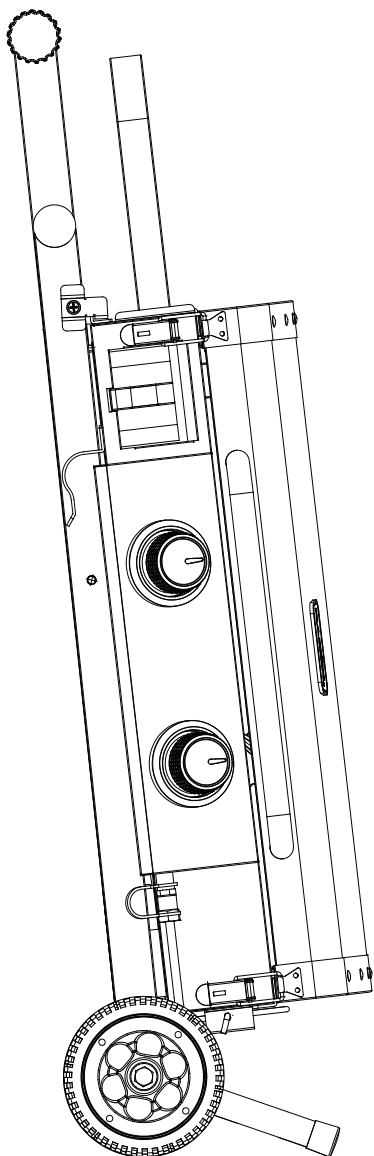

Installing 20lb LP Gas Tank

1 Attach Regulator

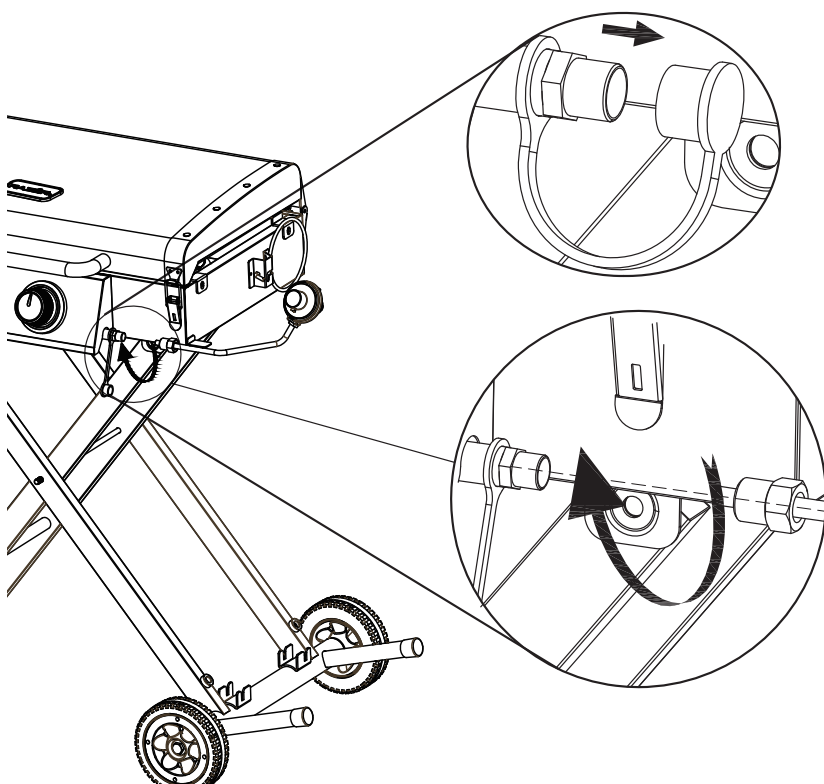

2 Attach Adapter Hose for 20 lb Tank (Not included).

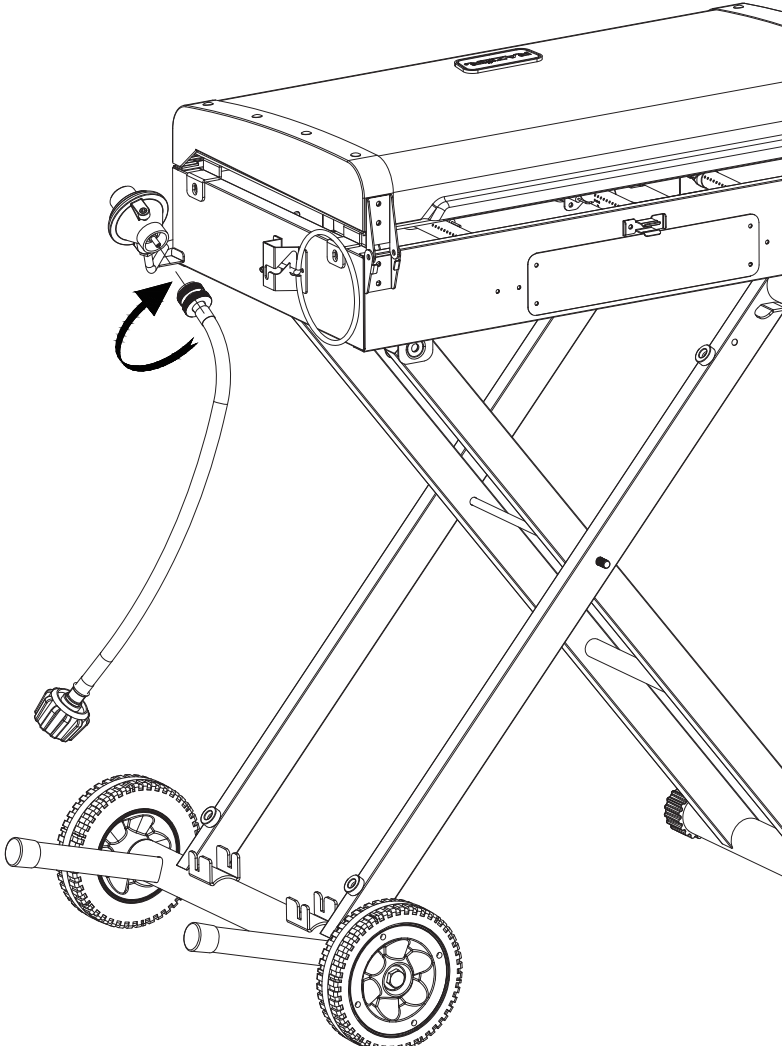

3 Secure LP Gas Tank (Not included)

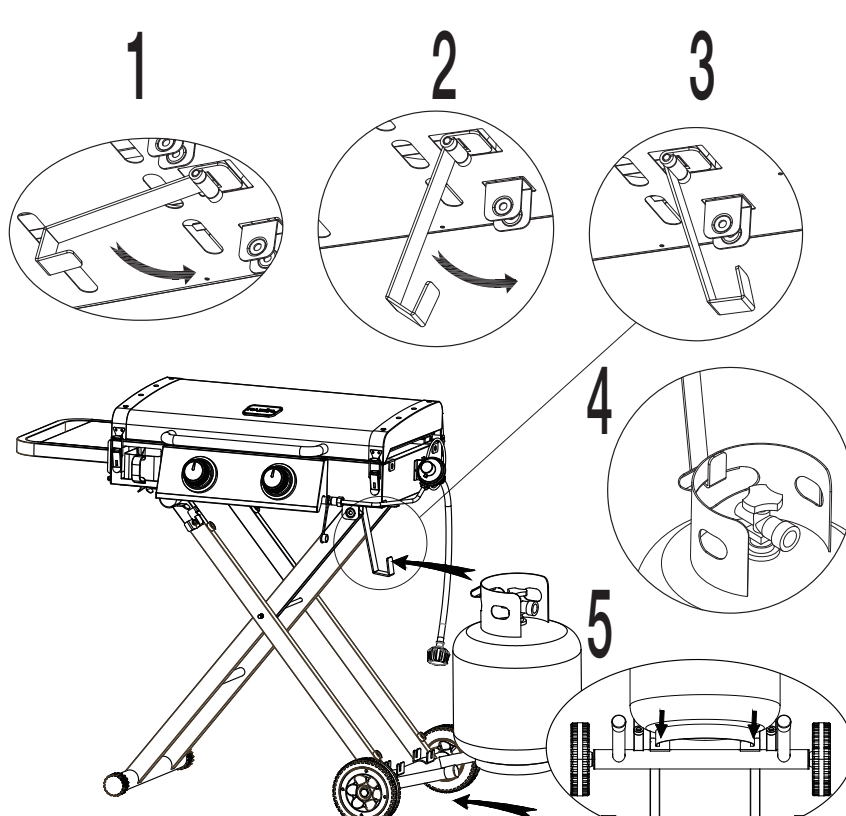

4 Connect and Disconnecting LP Gas Tank

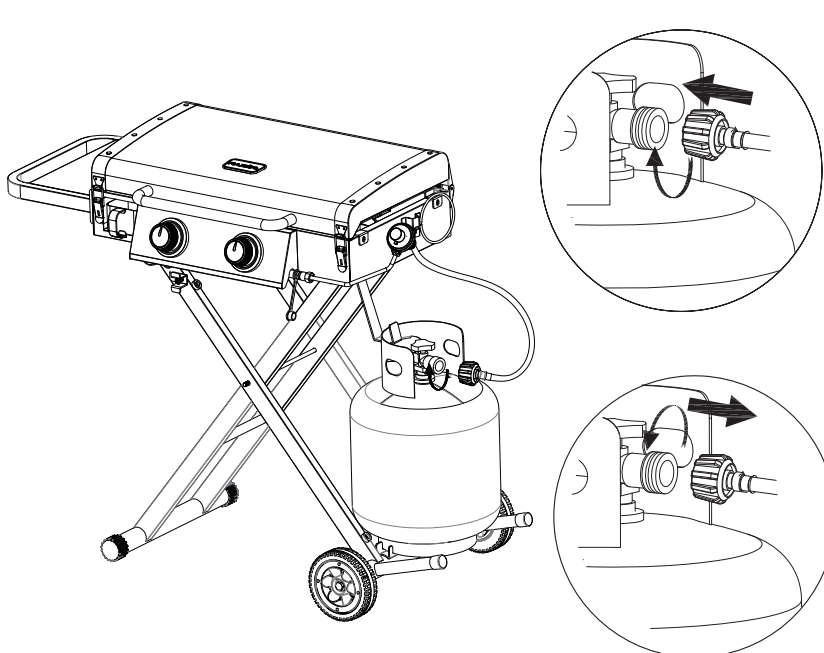

IMPORTANT

Before first use and after each use, always season your griddle per “Seasoning Griddle” section.

Installing LP Gas Tank

This griddle is designed to operate with a 1 lb. 7.75 in. or 10.6 in. high disposable / 16.4 oz. or 14.1 oz. propane gas tank (DOT 39 Cylinder) (Figure 1).

DO NOT ATTEMPT TO REFILL ANY 1 lb. (16.4 oz. or 14.1 oz.) PROPANE GAS TANKS!

Connecting LP Gas Tank

Only cylinders marked “propane” may be used.

Note: 1 lb cylinders may form frost when near empty.

1. Make sure the control knob is in the “● OFF” position (Figure 3).
2. Lubricate the threads of the regulator with petroleum jelly. Line up threads on LP gas tank with regulator.
3. Insert and rotate LP gas tank clockwise until they fit snugly together. **HAND TIGHTEN ONLY.** Be careful not to crossthread when screwing in tank (Figure 4).
4. Perform leak test per “Checking for Leaks” section.

Disconnecting LP Gas Tank

CAUTION: The LP gas tank must be removed when this appliance is not in use.

1. Turn the control knob to the “● OFF” position (Figure 3).
2. Rotate LP gas tank counterclockwise until it is detached (Figure 5).
3. Store the LP gas tank in a proper location, per instructions on the LP gas tank.

Operating Instructions

Checking for Leaks

Burner Connections

1. Make sure the regulator is securely fastened.
Note: The brass nut should be ¼ to ½ turn past tight. The regulator will rotate 360° even when the brass nut is tightened.
 2. Visually check the connection between the burner and regulator (Figure 6).
 3. Make sure the burner/venturi tube fits over the orifice (Figure 2).
- WARNING: Failure to inspect this connection or follow these instructions could cause a fire or an explosion which can cause death, serious bodily injury or damage to property.**
4. Please refer to diagram for proper installation (Figures 2 and 6)
 5. If the burner/venturi tube does not rest flush to the orifice, as shown, please contact 1.800.694.0013 for assistance
 6. If the burner and regulator do not fit properly or if you have any questions, please contact 1.800.694.0013 for assistance.

Tank/Gas Line Connection

1. Make 2-3 oz. of leak detection solution by mixing one part liquid dishwashing soap with three parts water.
2. Make sure control knob is in the “● OFF” position (Figure 3).
3. Apply the leak detection check solution on all “X” locations (Figure 6).

Figure 1

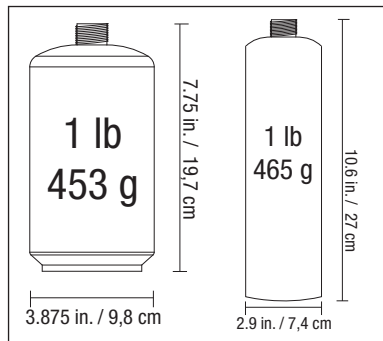

Figure 2

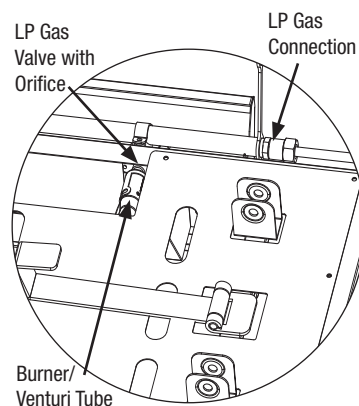

Figure 3

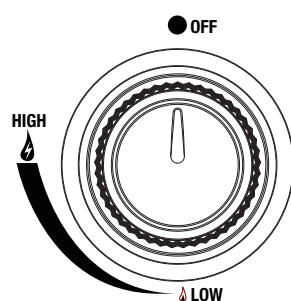

Figure 4

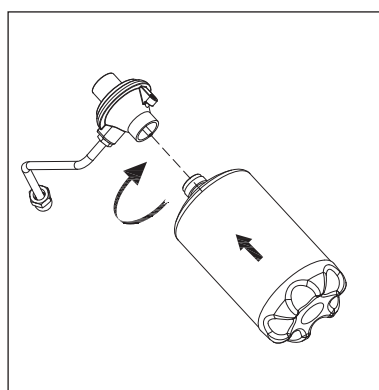

Figure 5

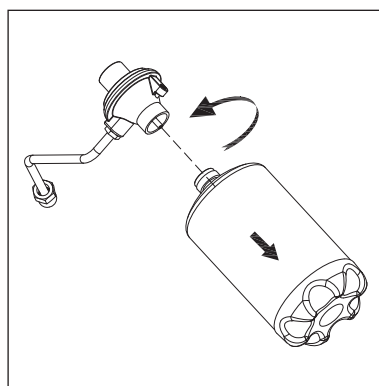
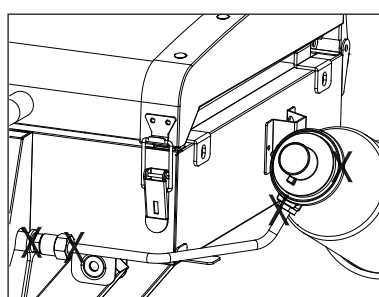

Figure 6



Operating Instructions (continued)

- a. If any bubbles appear, remove the LP gas tank and reconnect, making sure the connection is secure.
- b. If you continue to see bubbles after several attempts, remove the LP gas tank per “Disconnecting LP Gas Tank” section, and contact 1.800.694.0013 for assistance.
- c. If no bubbles appear after one minute, turn control knob to the “● OFF” position, wipe away solution and proceed.

First Use

1. Make sure all labels, packaging and protective films have been removed from the griddle.
2. Light griddle per “Lighting” section.
3. Remove manufacturing oils before cooking on this grill for the first time by operating the grill for at least 15 minutes on 🔥 (HIGH). This will “heat clean” the internal parts and dissipate odors.
4. **Season your griddle per “Seasoning Griddle” section.**

Operating the LP Gas Griddle

Lighting

- ▲ **CAUTION: Keep outdoor gas cooking appliance area clear and free from combustible materials, gasoline and other flammable vapors and liquids.**
- ▲ **CAUTION: Do NOT obstruct the flow of combustion and ventilation air.**
- ▲ **CAUTION: Check and clean burner/venturi tubes for insects and insect nests. A clogged tube can lead to a fire.**
- ▲ **CAUTION: Do NOT use non-stick cooking sprays because they contain a lot of water and can burn onto the griddle, damaging the surface.**
- ▲ **CAUTION: Do NOT use corn oil as it contains a high level of sugar, which can caramelize and burn onto the surface.**

1. Check for obstructions of airflow to the burners. Spiders, insects and webs can clog the burner/venturi tube. A clogged burner/venturi tube can lead to a fire.
2. Control knob must be in the “● OFF” position (Figure 3).
3. Connect LP gas tank per “Connecting LP Gas Tank” section.
4. Push and turn any control knob to 🔥 (HIGH). The burner should light. If it does not, repeat up to three times.
5. If ignition does not occur in 5 seconds, turn burner control knob “● OFF,” wait 5 minutes, and repeat lighting procedure.
6. If igniter does not light burner, use a lit match to light burner manually.
 - a. Access the burner through the hole in bottom bowl or side as indicated (Figure 7).
 - b. Turn the control knob to 🔥 (LOW) and position the lit match near side of the burner.

Figure 7

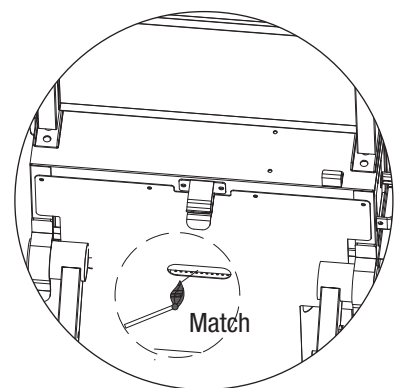
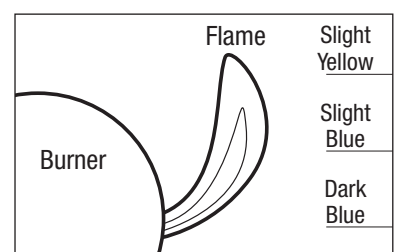

Figure 8



7. After lighting, observe the burner flame. Make sure all burner ports are lit and flame height matches illustration (Figure 8).

▲ **CAUTION: If burner flame goes out during operation, immediately turn the control knob “● OFF” and let the gas clear for 5 minutes before re-lighting.**

Turning Off

▲ **CAUTION: The LP gas tank must be removed when this appliance is not in use.**

1. Turn control knob to the “● OFF” position (Figure 3).
Note: A “poof” sound is normal as the last of the LP gas is burned.
2. Disconnect LP gas tank per “Disconnecting LP Gas Tank” section.
3. **Season your griddle per “Seasoning Griddle” section.**

Cooking

▲ **CAUTION: Do NOT leave griddle unattended while preheating or burning off food residue on 🔥 (HIGH). If griddle has not been cleaned, a grease fire can occur.**

1. Light griddle per “Lighting” section.
2. Preheat griddle on 🔥 (HIGH).
3. Adjust control knob to desired flame height.
4. Wear protective gloves and use long handle tongs to place food onto griddle surface.
5. Cook until desired internal food temperatures are achieved.
6. Turn griddle off per “Turning Off” section.

Controlling Flare-ups

Operating Instructions (continued)

⚠ CAUTION: Putting out grease fires by only closing the lid is not possible.

1. If a grease fire develops, turn control knob to the “● OFF” position. Do NOT use water on a grease fire. This can cause the grease to splatter and could result in serious burns, bodily harm or other damage.
2. Do NOT leave griddle unattended while preheating or burning off food residue on 🔥 (HIGH). If griddle has not been cleaned, a grease fire can occur.

⚠ WARNING: When cooking, fire extinguishing materials should be readily accessible. In the event of an oil/grease fire, use type BC dry chemical fire extinguisher or smother with dirt, sand or baking soda. Do NOT attempt to extinguish with water.

Flare-ups are a part of cooking meats on a griddle and add to the unique flavor of grilling.

Excessive flare-ups can over-cook your food and be dangerous.

Important: Excessive flare-ups result from the build-up of grease in the grease cup.

If a grease fire occurs, turn the control knob to “● OFF” until the grease burns out.

If excessive flare-ups occur, do NOT pour water onto the flames.

Minimize Flare-ups:

1. Trim excess fat from meats prior to cooking.
2. Cook high fat content meats on 🔥 (LOW) setting or indirectly.
3. Ensure that your griddle is on a hard, level, non-combustible surface and the grease is allowed to drain into grease receptacle.

Cleaning and Care

⚠ CAUTION:

1. All cleaning and maintenance should be done when griddle is cool and with the fuel supply disconnected.
2. Do NOT clean any griddle part in a self-cleaning oven. The extreme heat will damage the finish.
3. Do NOT enlarge valve orifices or burner ports when cleaning the valves or burners.

Notices

1. This griddle should be thoroughly cleaned and inspected on a regular basis.
2. Abrasive cleaners will damage this product.
3. Never use oven cleaner to clean any part of griddle.

Before Each Use

1. Keep the griddle area clean and free from any combustible materials, gasoline, and other flammable vapors and liquids.
2. Do NOT obstruct the flow of the combustion of LP gas and the ventilation of air.
3. Keep the ventilation opening(s) of the LP gas tank area free and clear from debris.
4. Visually check the burner flames to make sure your griddle is working properly (Figure 9).
5. See below for proper cleaning instructions.
6. Check for obstructions of airflow to the burners. Spiders, insects and webs can clog the burner/venturi tube. A clogged burner/venturi tube can lead to a fire.

Cleaning Surfaces

1. Wipe surfaces clean with mild dishwashing detergent or baking soda mixed with water.
2. For stubborn surfaces, use a citrus-based degreaser and a nylon scrubbing brush.
3. Rinse clean with water.
4. Allow to air dry.

Cleaning Main Burner

1. Turn off per “Turning Off” section.
2. Disconnect LP gas tank per “Disconnecting LP Gas Tank” section.
3. Remove control knob.
4. Remove griddle by lifting it off the cart.
5. Remove burner by removing the fasteners, which secure the burners to the frame bottom.
6. Lift burner up and away from gas valve orifice.

Cleaning and Care (continued)

7. Remove all food residue and dirt from burner surface.
8. Disconnect wire from spark electrode.
9. Clean inlet of burner with small bottle brush or compressed air.
10. Clean any clogged ports with a stiff wire (such as an opened paper clip).
11. Inspect burner for any damage (cracks or holes). If damage is found, replace with a new burner from manufacturer.
12. Re-install burner. Checking to insure that gas valve orifice is correctly positioned inside the burner/venturi tube. Also, check position of spark electrode.
13. Connect wire to spark electrode.
14. Replace griddle.
15. Connect LP gas tank per “Installing LP Gas Tank” section.
16. Perform leak test per “Checking for Leaks” section.

Before Storing

1. Turn off per “Turning Off” section.
2. Turn all control knobs clockwise to the “● OFF” position.
Note: A “poof” sound is normal as the last of the gas is burned.
3. Disconnect LP gas tank per “Disconnecting LP Gas Tank” section.
4. Clean all surfaces.
5. Lightly coat the burner and cooking grid with cooking oil to prevent excess rusting.
6. Season your griddle per “Seasoning Griddle” section.
7. If storing the griddle indoors, disconnect the LP tank per “Disconnecting LP Gas Tank” section.
8. Place the protective cap cover on the LP tank and store the tank outdoors in a well-ventilated area out of direct sunlight.
9. If storing the griddle indoors, cover the griddle and store in a cool dry place.
10. If storing the griddle outdoors, cover the griddle with a griddle cover for protection from the weather.

Seasoning Griddle

Important: season your griddle every time you use it.

Griddle chefs at Japanese steakhouses and short-order restaurants season their griddles all the time, and it is critical for you to do it too. Seasoning helps prolong the life of your griddle, makes the cooking surface non-stick and helps prevent rust.

For more information, please visit BlueRhino.com/RazorFAQ.

Tools needed for seasoning:

- Metal scraper or metal spatula
- Cooking oil, such as vegetable oil or extra virgin olive oil
- Paper towels
- BBQ stone or steel wool

⚠ CAUTION: Do NOT use corn oil as it contains a high level of sugar, which can caramelize and burn onto the griddle surface.

First Use

1. Light griddle per “Lighting” section.
2. Keep burners on 🔥 (HIGH) for 15 minutes.
3. Turn griddle off per “Turning Off” section.
4. Allow griddle to cool, but still be slightly warm.
5. Wipe off griddle surface, inner and outer walls with paper towels until clean.
Note: While drying you may notice the towel may have some discoloration. This is normal.
6. Apply cooking oil onto griddle surface, inner and outer walls and evenly coat with rolled up paper towels.
7. Repeat this process at least twice.

After Each Use

1. Turn griddle off per “Turning Off” section.
2. While the griddle is still warm, gently scrape off all food residue with a scraper.
3. Wipe down griddle surface, inner and outer walls with a towel or paper towels.
4. For stubborn food residue:
 - a. Light griddle per “Lighting” section.
 - b. Apply cooking oil onto griddle surface.
 - c. Allow oil to “boil” food residue off.
 - d. Repeat steps 1 through 3.
 - e. If necessary, use a BBQ stone and scrub the food residue off.
 - f. Continue with “Seasoning Griddle” instructions.
5. Wipe off griddle surface, inner and outer walls with paper towels until clean.
Note: While drying you may notice the towel has some discoloration. This is normal.
6. Apply finishing oil onto griddle surface, inner and outer walls and evenly coat with rolled up paper towels.
7. Light griddle per “Lighting” section.
8. Keep burners on 🔥 (HIGH) for 15 minutes or until cooking oil starts to smoke.
9. Turn griddle off per “Turning Off” section.
10. Repeat steps 6-9 a minimum of 2 additional times.
11. Following “Before Storing” section.

Figure 9

Burner Flame Conditions

Use this chart to see if your burners need to be cleaned.

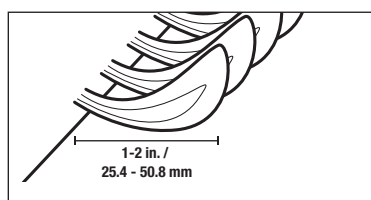

Normal: Soft blue flames with yellow tips between 1 in. - 2 in. height.

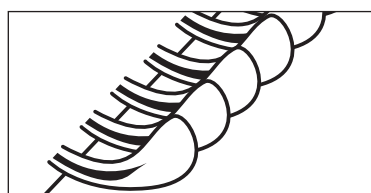

Needs cleaning: Noisy with hard blue flames.

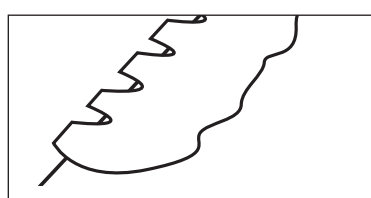

Has to be replaced: Wavy with yellow flames.

Cleaning and Care (continued)

Refurbish the Griddle Surface

1. If griddle is off, light per "Lighting" section for 10 minutes. Then turn griddle off per "Turning Off" section.
2. If griddle is on, turn griddle off per "Turning Off" section.
3. While the griddle is still warm, use a scraper or metal spatula to remove as much rust and food residue as you can from the griddle surface, inner and outer walls.
4. Apply a liberal amount of cooking oil onto the griddle surface.
5. Using a BBQ stone, scrub the griddle surface. Apply additional cooking oil as need.
6. Wipe off griddle surface, inner and outer walls with paper towels.
7. Repeat steps 3-5 until paper towels no longer show any rust.
8. Apply cooking oil onto griddle surface, inner and outer walls and evenly coat with rolled up paper towels.
9. Light griddle per "Lighting" section.
10. Keep burners on 🔥 (HIGH) for 15 minutes or until cooking oil starts to smoke.
11. Turn griddle off per "Turning Off" section.
12. Repeat steps 7-10 until the surface has a nice dark color.
13. Follow "Before Storing" section.

Product Registration

For faster warranty service, please register your product immediately. To register, call 1.800.694.0013.

Replacement Parts

For replacement parts, call 1.800.694.0013.

Limited Warranty

RevoAce Inc. Limited ("manufacturer") warrants to the original retail purchaser of this product,

and to no other person, that if this product is assembled, maintained, and operated in accordance with the printed instructions accompanying it, then for a period of one (1) year from the date of purchase, all parts in such product shall be free from defects in material and workmanship. Manufacturer may require reasonable proof of your date of purchase. Therefore, you should retain your sales slip or invoice. This Limited Warranty shall be limited to the repair or replacement of parts, which prove defective under normal use and service and which manufacturer shall determine in its reasonable discretion upon examination to be defective. Before returning any parts, you should contact manufacturer's Customer Service Department using the contact information listed below. If manufacturer confirms, after examination, a defect covered by this Limited Warranty in any returned part, and if manufacturer approves the claim, manufacturer will replace such defective part without charge. If you return defective parts, transportation charges must be prepaid by you. manufacturer will return replacement parts to the original retail purchaser, freight or postage prepaid.

This Limited Warranty does not cover any failures or operating difficulties due to accident, abuse, misuse, alteration, misapplication, improper installation or improper maintenance or service by you or any third party, or failure to perform normal and routine maintenance on the product as set out in this owner's manual. In addition, the Limited Warranty does not cover damage to the finish, such as scratches, dents, discoloration, rust or other weather damage, after purchase.

This Limited Warranty is in lieu of all other express warranties. manufacturer disclaims all warranties for products that are purchased from sellers other than authorized retailers or distributors, including the warranty of merchantability or the warranty of fitness for a particular purpose. MANUFACTURER ALSO DISCLAIMS ANY AND ALL IMPLIED WARRANTIES, INCLUDING WITHOUT LIMITATION THE IMPLIED WARRANTIES OF MERCHANTABILITY AND FITNESS FOR A PARTICULAR PURPOSE. MANUFACTURER SHALL HAVE NO LIABILITY TO PURCHASER OR ANY THIRD PARTY FOR ANY SPECIAL, INDIRECT, PUNITIVE, INCIDENTAL, OR CONSEQUENTIAL DAMAGES. manufacturer further disclaims any implied or express warranty of, and assumes no responsibility for, defects in workmanship caused by third parties.

This Limited Warranty gives the purchaser specific legal rights; a purchaser may have other rights depending upon where he or she lives. Some jurisdictions do not allow the exclusion or limitation of special, incidental or consequential damages, or limitations on how long a warranty lasts, so the above exclusion and limitations may not apply to everyone. manufacturer does not authorize any person or company to assume for it any other obligation or liability in connection with the sale, installation, use, removal, return, or replacement of its equipment, and no such representations are binding on manufacturer.

RevoAce Inc. Limited
Hong Kong, China
service@revoace.com
1.800.694.0013

8:00 am to 4:00 pm central time, Monday to Friday.

Troubleshooting

Problem	Possible Cause	Prevention/Cure
Burner will not light using igniter	LP gas tank is low or empty	Replace LP gas tank
	LP gas leak	1. Disconnect LP gas tank per “Disconnecting LP Gas Tank” section. 2. Wait 5 minutes for gas to clear 3. Connect LP gas tank per “Connecting LP Gas Tank” section. 4. Follow “Checking for Leaks” section
	Bottom bowl and ash pan are covered with ashes	Clear bottom bowl and ash pan of ashes
	Wires or electrode covered with cooking residue	Clean wire and/or electrode with rubbing alcohol
	Electrode and burners are wet	Wipe dry with cloth
	Electrode cracked or broken - sparks at crack	Replacement part(s) may be needed - contact Customer Care at 1.800.694.0013
	Wire loose or disconnected	Reconnect wire or replacement part(s) may be needed - contact Customer Care at 1.800.694.0013
	Wire is shorting (sparking) between igniter and electrode	Replacement part(s) may be needed - contact Customer Care at 1.800.694.0013
Bad igniter	Replacement part(s) may be needed - contact Customer Care at 1.800.694.0013	
Burner will not light with match	No gas flow	Check if LP gas tank is empty A. If empty, replace B. If LP gas tank is not empty, refer to “Sudden drop in gas flow or reduced flame height” below
	LP gas tank is low or empty	Replace LP gas tank
	LP gas leak	1. Disconnect LP gas tank per “Disconnecting LP Gas Tank” section. 2. Wait 5 minutes for gas to clear 3. Connect LP gas tank per “Connecting LP Gas Tank” section. 4. Follow “Checking for Leaks” section
	Coupling nut and regulator not fully connected	Turning the coupling nut about one-half to three-quarters additional turn until solid stop. Tighten by hand only – do NOT use tools.
	Obstruction of gas flow	Clear burner/venturi tube
	Spider webs or insect nest in venturi	Clean burner/venturi tube
	Burner port is clogged or blocked	Clean burner port
Sudden drop in gas flow or reduced flame height	Out of gas	Replace LP gas tank
Irregular flame pattern – flame does not run the full length of burner	Burner port is clogged or blocked	Clean burner port
Flame is yellow or orange	New burner may have residual manufacturing oils	Operate griddle for 15 minutes on 🔥 (HIGH)
	Spider webs or insect nest in burner/venturi tube	Clean burner/venturi tube
	Food residue, grease, etc. on burner	Clean burner
	Poor alignment of valve to burner/venturi tube	Ensure burner/venturi tube is properly engaged with valve
Flame goes out	High or gusting winds	DO NOT use griddle in high winds
	Low on LP gas	Replace LP gas tank
	Overflow valve tripped	Refer to “Sudden drop in gas flow or reduced flame height,” above
Flare-up	Grease buildup	Remove and clean all griddle parts per “Cleaning and Care” section
	Excess fat in meat	Trim fat from meat before cooking
	Excessive cooking temperature	Adjust (lower) cooking temperature
Persistent grease fire	Grease trapped by food buildup around burner system	1. Turn control knob to “● OFF” 2. Let fire burn out 3. After griddle cools, remove and clean all griddle parts per “Cleaning and Care” section
Flashback (fire in burner tube(s))	Burner and/or burner tubes are blocked	Clean burner and/or burner/venturi tube

For more assistance, please call 1.800.694.0013.

