

Owner's Manual & Assembly Guide

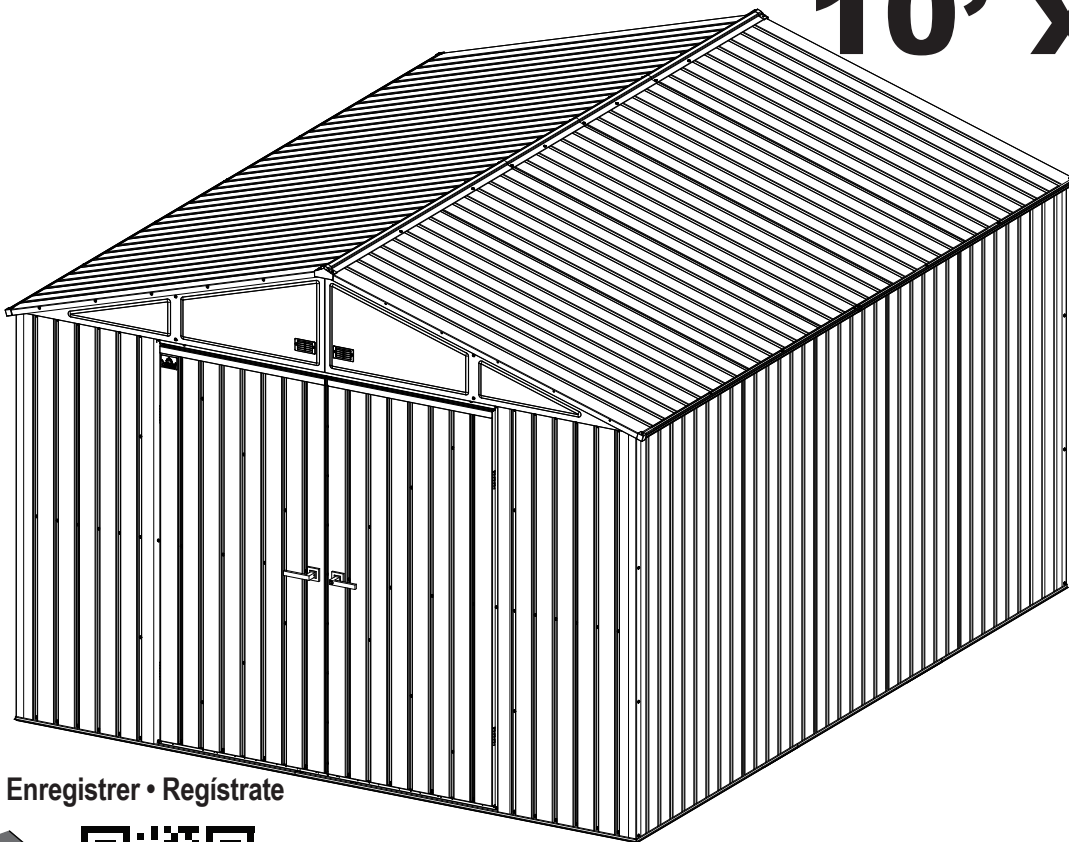

Model No. **Steel Shed**
EG1012AB **EG1012AN**
EG1012BG **EG1012CG**
10' x 12'
 Nominal Size



Register • Enregistrer • Registrare

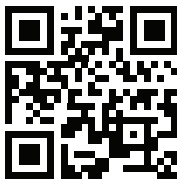

ShelterLogic.com/product-registration

arrowsheds.com

Visit our website for compatible accessories

Base Size	121 1/8" x 145 1/8" 307,6 cm x 368,6 cm
------------------	--

BUILDING DIMENSIONS

†Size rounded off to the nearest foot

For proper base construction see page 12

Approx. † Size	Storage Area	Exterior Dimensions (Roof Edge to Roof Edge)			Interior Dimensions (Wall to Wall)			Door Opening	
		Width	Depth	Height	Width	Depth	Height	Width	Height
10' x 12'	117 Sq. Ft. 793 Cu. Ft.	122 7/8"	144 11/16"	91 3/8"	118 3/8"	142 3/8"	90 1/8"	63 7/16"	69 3/4"
3,0 m x 3,7 m	10,9 m ² 22,5 m ³	312,2 cm	367,5 cm	232,2 cm	300,6 cm	361,6 cm	229,0 cm	161,1 cm	177,2 cm

* See Inside for Detailed Safety Information.

Visitez notre site Web pour des accessoires compatibles

Manuel de l'utilisateur et guide d'assemblage



Taille de la base 121 1/8" x 145 1/8"
307,6 cm x 368,6 cm

DIMENSIONS DU COFFRE

†Dimension arrondie au pied le plus proche

Taille † approx.	Zone d'entreposage		Dimensions extérieures (de bordure de toit à bordure de toit)			Dimensions intérieures (de paroi à paroi)			Ouverture de porte	
			Largeur	Profondeur	Hauteur	Largeur	Profondeur	Hauteur	Largeur	Hauteur
10' x 12'	117 Sq. Ft.	793 Cu. Ft.	122 7/8"	144 11/16"	91 3/8"	118 3/8"	142 3/8"	90 1/8"	63 7/16"	69 3/4"
3,0 m x 3,7 m	10,9 m ²	22,5 m ³	312,2 cm	367,5 cm	232,2 cm	300,6 cm	361,6 cm	229,0 cm	161,1 cm	177,2 cm

* Voir les informations de sécurité détaillées à l'intérieur.

Para accesorios compatibles, visite nuestro sitio web

Manual del propietario e instrucciones de ensamblaje



Tamaño básico 121 1/8" x 145 1/8"
307,6 cm x 368,6 cm

DIMENSIONES DE LA UNIDAD

† Las medidas están redondeadas en pies

Tamaño † aproximado	Área de almacenaje		Dimensiones exteriores (borde a borde del techo)			Dimensiones interiores (pared a pared)			Abertura de la puerta	
			Ancho	Profundidad	Altura	Ancho	Profundidad	Altura	Ancho	Altura
10' x 12'	117 Sq. Ft.	793 Cu. Ft.	122 7/8"	144 11/16"	91 3/8"	118 3/8"	142 3/8"	90 1/8"	63 7/16"	69 3/4"
3,0 m x 3,7 m	10,9 m ²	22,5 m ³	312,2 cm	367,5 cm	232,2 cm	300,6 cm	361,6 cm	229,0 cm	161,1 cm	177,2 cm

* Consulte en el interior para obtener la seguridad de información detallada.

Besuchen Sie unsere Webseite für kompatibles Zubehör

Pflege- & Montageanleitung



Bodenabmessungen 121 1/8" x 145 1/8"
307,6 cm x 368,6 cm

ABMESSUNGEN

†Angaben auf ganze Fuß gerundet

Ungefähre † Größe	Lagerfläche		Außenabmessungen (Dachkante zu Dachkante)			Innenabmessungen (Wand zu Wand)			Türöffnung	
			Breite	Tiefe	Höhe	Breite	Tiefe	Höhe	Breite	Höhe
10' x 12'	117 Sq. Ft.	793 Cu. Ft.	122 7/8"	144 11/16"	91 3/8"	118 3/8"	142 3/8"	90 1/8"	63 7/16"	69 3/4"
3,0 m x 3,7 m	10,9 m ²	22,5 m ³	312,2 cm	367,5 cm	232,2 cm	300,6 cm	361,6 cm	229,0 cm	161,1 cm	177,2 cm

* Detaillierte Sicherheitsinformationen im Inneren.

CAUTION / ATTENTION / PRECAUCIONES/ VORSICHT

EN,FR,SP,GE-04HN

- Care must be taken when handling various pieces of your building since many contain sharp edges.
- Faire preuve de précaution pour manipuler les différentes pièces de l'abri car elles présentent de nombreux bords coupants.
- Tenga cuidado al manipular las diferentes piezas de la estructura ya que pueden tener bordes filosos.
- Verschiedene Teile Ihres Schuppens müssen vorsichtig gehandhabt werden, denn viele haben scharfe Kanten.



- Do NOT attempt to assemble your building before double checking that you have all the parts indicated in the parts lists. Any building left partially assembled may be seriously damaged by even light winds.
- Ne PAS tenter d'assembler l'abri avant d'avoir vérifié la présence de toutes les pièces figurant dans la liste des pièces. Tout abri laissé partiellement assemblé peut être gravement endommagé par des vents même légers.
- NO trate de montar la estructura antes de verificar que tenga todas las piezas indicadas en la lista de piezas. Cualquier estructura sin terminar puede ser dañada seriamente incluso por vientos ligeros.
- Versuchen Sie NICHT, Ihren Schuppen an einem windigen Tag aufzustellen. Die großen, flächigen Bauteile könnten wie ein Segel vom Wind erfasst und herumgeschleudert werden, was die Aufstellarbeiten erschwert und gefährlich macht.
- Do NOT attempt to assemble your building on a windy day. The large panels can catch the wind like a "sail", making construction difficult and unsafe. **Watch the Weather Closely**
- Ne PAS tenter d'assembler l'abri en présence de vent. Les grands panneaux peuvent se comporter comme une voile et « battre » au vent, rendant la construction difficile et dangereuse. **Suivre la météo avec attention**
- NO trate de montar la estructura en un día ventoso. Los paneles grandes pueden atrapar el viento como una "vela", lo que hace que sean llevados por el viento, lo que, a su vez, hace que la construcción sea difícil e insegura. **Observe el clima atentamente**
- Versuchen Sie NICHT, Ihren Schuppen zu montieren, bevor Sie sich nochmals vergewissert haben, dass Sie alle in der Teilleiste. Ein nur teilweise montiert zurückgelassener Schuppen kann bereits durch leichten Wind schwer beschädigt werden.
- Keep children and pets away from the worksite during construction and until the building is completely assembled. This will help avoid distractions and any accidents which may occur.
- Tenir les enfants et les animaux domestiques à l'écart du chantier durant la construction et jusqu'à ce que l'abri soit complètement assemblé. Cela évite les distractions et les accidents potentiels.
- No permita entrar a niños ni animales domésticos en el lugar de trabajo durante la construcción y hasta que la estructura esté completamente montada. Esto ayudará a evitar distracciones y cualquier accidente que pueda producirse.
- Halten Sie Kinder und Haustiere während der Montage und bis der Schuppen vollständig aufgestellt ist vom Aufstellplatz fern. Dies hilft, Ablenkungen und damit einhergehende Unfälle zu verhindern.
- NEVER concentrate your weight on the roof of the building.
- NE JAMAIS concentrer son propre poids sur le toit de l'abri.
- NUNCA concentre su peso en el techo de la estructura.
- Belasten Sie das Dach des Schuppens NIEMALS punktuell mit Ihrem Gewicht.
- Before assembling any parts, your base should be constructed and an anchoring system should be ready to use. Your building MUST be anchored to prevent wind damage.
- Avant de commencer à assembler des pièces, la base doit avoir été construite et le système d'ancrage doit être prêt à l'emploi. L'abri doit IMPÉRATIVEMENT être ancré pour éviter les dommages par le vent.
- Antes de montar cualquier pieza, debe estar construida la base y preparado el sistema de anclaje. La estructura DEBE estar anclada para evitar daños por vientos.
- Das Fundament sollte vor dem Zusammenbau der Teile gebaut und das Verankerungssystem nutzungsbereit sein. Ihr Schuppen MUSS verankert werden, um Schäden durch Wind zu verhindern.



- The best location is a level area with good drainage.
- Le meilleur emplacement sera une surface de niveau à bon drainage.
- El mejor lugar es un área nivelada con buen drenaje.
- Der bestmögliche Bauplatz ist eben mit einer guten Drainage.
- Allow enough space outside the building to be able to access the roof with a ladder.
- Laissez suffisamment d'espace à l'extérieur du bâtiment pour être en mesure d'accéder à la toiture avec une échelle.
- Deje suficiente espacio afuera del edificio para poder tener acceso al techo con una escalera.
- Es muß außerdem genügend Platz außerhalb des Gerätehauses vorgesehen werden, damit die Blechschrauben von außen aus verschraubt werden können.
- **Use Teamwork:** Two or more people are required to assemble your building.
- **Travailler en équipe:** Deux personnes ou plus sont nécessaires pour assembler l'abri.
- **Trabaje en equipo:** Se necesitan dos o más personas para ensamblar su cobertizo.
- **Arbeiten Sie im Team:** Mindestens zwei Personen werden für die Montage des Gerätehauses benötigt.

**CARE & MAINTENANCE / SOINS ET ENTRETIEN / PROTECCIÓN Y CONSERVACIÓN/
PFLEGE & INSTANDHALTUNG**

- DO NOT use power washing to clean your shed.
- NE PAS utiliser de jet sous haute pression pour nettoyer l'abri.
- NO utilice hidrolavadora para limpiar el cobertizo.
- Reinigen Sie Ihren Schuppen NICHT mit dem Hochdruckreiniger.
- Combustibles and corrosives must be stored in air tight containers designed for chemical and/or combustible storage. Corrosive chemicals such as fertilizers, pesticides and herbicides should be cleaned off the interior and exterior surfaces immediately. Rust caused by chemical damage is not covered by the warranty.
- Les matières combustibles et corrosives doivent être entreposées dans des contenants étanches à l'air conçus pour l'entreposage de produits chimique et/ou combustibles. Les produits chimiques corrosifs tels que les engrais, pesticides et herbicides doivent immédiatement être nettoyés des surfaces intérieures et extérieures. La rouille causée par des produits chimiques n'est pas couverte par la garantie.
- Los combustibles y productos corrosivos deben guardarse en contenedores herméticos diseñados para almacenamiento de químicos o combustibles. Se deben limpiar inmediatamente los químicos corrosivos, como fertilizantes, pesticidas y herbicidas, de las superficies interiores y exteriores. El óxido causado por daños químicos no está cubierto por la garantía.
- Brennbare und ätzende Stoffe müssen in luftdichten Behältern gelagert werden, die zur Lagerung von Chemikalien und/oder Brennstoffen vorgesehen sind. Ätzende Chemikalien wie z. B. Dünger, Insektenvernichter und Unkrautvernichter sollten sofort von den Innen- und Außenflächen abgewischt werden. Durch die Lagerung von Chemikalien entstandener Rost wird nicht von der Gewährleistung abgedeckt.

**Rust protection precautions / Des mesures de protection contre la rouille /
Las precauciones de protección contra el óxido/ Rostschutzmaßnahmen**

- Avoid nicking or scraping the coating surface, inside and out.
- Éviter d'entailler ou de rayer le revêtement de surface, à l'intérieur comme à l'extérieur.
- Evite dañar o raspar la capa protectora, por dentro y por fuera.
- Vermeiden Sie es, die Oberflächenbeschichtung an der Innen- und Außenseite zu beschädigen oder zu verkratzen.
- Keep roof, base perimeter and door free of debris.
- Nettoyer le toit, le pourtour de la base et les rails de porte de tous débris.
- Mantenga el techo, el perímetro de la base y los rieles de la puerta sin desechos.
- Halten Sie das Dach, den Bodenbereich und die Türführungen stets frei von Verunreinigungen.
- Touch up scrapes or nicks and any area of visible rust as soon as possible.
- Retoucher les entailles et égratignures et toute surface de rouille visible dès que possible.
- Retoque las raspaduras o las muescas y cualquier área de todo óxido visible lo más pronto posible.
- Bessern Sie Kratzer oder Beschädigungen und alle Bereiche mit sichtbarem Rost so schnell wie möglich aus.

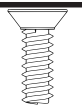





Key No. Rep. N.º de referencia Lfd. Nr.	Part No. Réf. pièce N.º de pieza Art.-Nr.	Part Description	Description de la pièce	Descripción de la pieza	Bezeichnung	Qty. Qté Cant. Menge	Part Views Profils de pièces Vistas desde un extremo Vor-handen
1	65103	Hex Nut (#8-32) / Écrou hexagonal (8-32) / Tuerca hexagonal (N.º 8-32) / Sechskantmutter (#8-32)				309	
2	65923	Small Bolt (#8-32 x 3/8) (10 mm) / Petit boulon (8-32 x 3/8) (10 mm) / Perno pequeño color arena (N.º 8-32 x 3/8) (10 mm) / Kleine Maschinenschraube (#8-32 x 3/8) (10 mm)				285	
3	65004	Small Screw (#8AB x 5/16) (8 mm) / Petite vis (8AB x 5/16) (8 mm) / Tornillo pequeño color arena (N.º 8AB x 5/16) (8 mm) / Kleine Blechschraube (#8AB x 5/16) (8 mm)				479	
4	66783	Flathead Bolt (#8-32 x 1/2) (13 mm) / Boulon à tête plate (#8-32 X 1/2) (13 mm) / Perno de cabeza chata (N.º 8-32 x 1/2) (13 mm) / Senkkopf-Maschinenschraube (#8-32 x 1/2) (13 mm)				24	

The fasteners used in each step are shown actual size at the top of each page. If you are unsure which fastener to use, hold it up to the picture and use the one that matches.

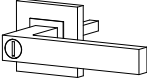
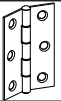
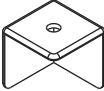
Les éléments de visserie utilisés à chaque étape sont représentés en taille réelle en haut de chaque page. En cas de doute sur le type de visserie à utiliser, les placer sur l'image et utiliser celui qui correspond.

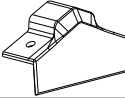
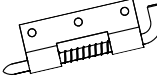
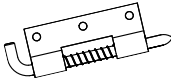
Los tornillos y pernos que se utilizan en cada paso se muestran en el tamaño real en la parte superior de cada página. Si no está seguro de qué tornillo o perno de usar, compárelo con la imagen y use el que coincida con ella.

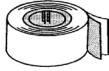
Die in den jeweiligen Schritten verwendeten Verbindungselemente werden am oberen Seitenrand jeweils in tatsächlicher Größe gezeigt. Falls Sie unsicher sind, welches Verbindungselement Sie verwenden sollen, dann halten Sie es vor das Bild und verwenden Sie dasjenige, das passt.

Key No. Rep. N.º de referencia Lfd. Nr.	Part No. Réf. pièce N.º de pieza Art.-Nr.	Part Description	Description de la pièce	Descripción de la pieza	Bezeichnung	Qty. Qté Cant. Menge	Part Views Profils de pièces Vistas desde un extremo Vor-handen
5	30000	Locking Handle Right	Poignée verrouillable droite	Manija de bloqueo derecha	Verriegelungsgriff rechts	1	
6	30040	Hinge	Charnière	Bisagra	Scharnier	4	
7	60H	Corner Cap	Coin bouchon	Tapa de esquina	Dachleisten-Abschlusskappe	4	
8	66646	Washer Sheet	Plaque de rondelles	Plancha de arandelas	Unterlegscheiben	12	
9	30026	Peak Cap	Embout de faîte	Tope del caballete	Firstkappe	2	
10	66808	Latch Spring	Verrou à ressort	Resorte de aldaba inferior	Schnappriegel unten	1	
11	66684	Latch Spring	Verrou à ressort	Resorte de aldaba superior	Schnappriegel oben	1	
12	30001	Left Handle	Poignée droite	Manija izquierda	Linker Griff	1	
13	66847	Gable Vent	Grilles de ventilation	Rejillas de ventilación	Dachgiebelentlüfter	4	
14	67293	Weather Stripping	Ruban de calfeutrage	Burlete	Dichtungsband	1	
15	30028	Nameplate	Plaque signalétique	Placa de identificación	Typenschild	1	

PARTS LIST

LISTE DES PIÈCES
ARTÍCULOS DE FERRETERÍA TEILELISTE









EN,FR,SP,GE-07MC

Key No. Rep. N.º de referencia Lfd. Nr.	Part No. Réf. pièce N.º de pieza Art.-Nr.	Part Description	Description de la pièce	Descripción de la pieza	Bezeichnung	Qty. Qté Cant. Menge	Part Views Profils de pièces Vistas desde un extremo Vor-handen
16	11380	Floor Frame / Cadre de plancher / Tirante del entramado del piso / Bodenrahmen				4	
17	11363	Ramp / Seuil / Rampa / Türschwelle				1	
18	11340	Rear Corner Panel / Panneau de coin arrière / Panel esquinero trasero / Eckblech hinten				2	
19	11391	Front Corner Panel / Panneau d'angle avant / Panel de la delantero esquina / Eckblech vorne				2	
20	11342	Side Corner Panel / Panneau de mur latéral / Panel esquinero lateral / Eckblech Seiten				4	
21	11343	Wall Panel / Panneau de mur / Panel de la pared / Wandblech				14	
22	11392	Wall Panel / Panneau de mur / Panel de la pared / Wandblech				2	
23	11691	Wall Channel / Longeron de mur / Canaleta de la pared / Wandverstrebung				6	
24	11692	Wall Channel Front / Canal mur avant / Canal frontal de pared / Vorderseite Kanalwand				2	
25	11690	Side Wall Angle / Cornière de mur latéral / Ángulo de la pared lateral / Seitenwandwinkel				4	
26	11383	Rear Wall Angle / Cornière arrière / Ángulo de la pared trasera / Rückwandwinkel				2	
27	11365	Lintel / Linteau / Dintel / Sturz				1	
28	11385	End Lintel / Linteau d'extrémité / Final del dintel / Ende des Türsturzes				2	
29	11348	Door Jamb Right / Jambage de porte droit / Jamba de la puerta derecha / Türpfosten rechts				1	

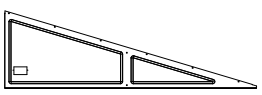
PARTS LIST

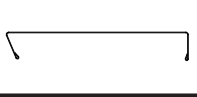
LISTE DES PIÈCES
ARTÍCULOS DE FERRETERÍA TEILELISTE

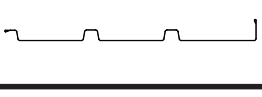
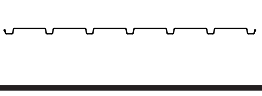
EN,FR,SP,GE-08MC

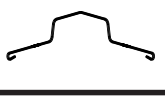
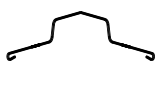
Key No. Rep. N.º de referencia Lfd. Nr.	Part No. Réf. pièce N.º de pieza Art.-Nr.	Part Description	Description de la pièce	Descripción de la pieza	Bezeichnung	Qty. Qté Cant. Menge	Part Views Profils de pièces Vistas desde un extremo Vor-handen
30	80209	Door Jamb Left / Jambage de porte gauche / Jamba de la puerta izquierda / Türpfosten links				1	
31	9009	Gable Brace / Renfort de pignon / Abrazadera del gablete / Giebelverstärkung				2	
32	6635	Gable Brace / Renfort de pignon / Abrazadera del gablete / Giebelverstärkung				4	
33	11398	Right Gable / Pignon droit / Gablete derecho / Giebel rechts				2	
34	80221	Left Gable / Pignon gauche / Gablete izquierdo / Giebel links				2	
35	11693	Roof Beam / Poutre de toit / Viga del techo / Dachträger				12	
36	9204	Roof Beam Brace / Contrefiche de poutre de toit / Abrazadera de la viga del techo / Dachträger verstärkung				2	
37	11387	Right Roof Panel / Panneau de toit droit / Panel del techo derecho / Dachblech rechts				2	
38	80215	Left Roof Panel / Panneau de toit gauche / Panel del techo izquierdo / Dachblech links				2	
39	11388	Roof Panel / Panneau de toit / Panel del techo / Dachblech				10	
40	11352	Roof Trim / Garniture de toit / Contramarco del techo / Dachabschlussleiste				2	
41	11453	Roof Trim / Garniture de toit / Contramarco del techo / Dachabschlussleiste				2	
42	11390	Ridge Cap / Faîtage / Tope del caballete / Firstabdeckung				1	
43	11399	Ridge Cap / Faîtage / Tope del caballete / Firstabdeckung				1	

PARTS LIST

LISTE DES PIÈCES
ARTÍCULOS DE FERRETERÍA TEILELISTE

EN,FR,SP,GE-09MC

Key No. Rep. N.º de referencia Lfd. Nr.	Part No. Réf. pièce N.º de pieza Art.-Nr.	Part Description	Description de la pièce	Descripción de la pieza	Bezeichnung	Qty. Qté Cant. Menge	Part Views Profils de pièces Vistas desde un extremo Vor-handen
44	11452	Ridge Cap / Faîtage / Tope del caballete / Firstabdeckung				2	
45	11371	Door Panel Hinge Side / Coté charnière du panneau de porte / Panel de puerta lateral de bisagra / Türverkleidung Bandseite				1	
46	11372	Door Panel / Panneau porte / Panel puerta / Tür				2	
47	11373	Door Edge / Bord de porte / Borde de la puerta / Türkante				2	
48	11374	Vertical Door Channel / Canal d'ouverture verticale de la porte / Canal de puerta vertical / Vertikale Türschiene				4	
49	11375	Horizontal Door Channel / Canal d'ouverture horizontale de la porte / Canal de puerta horizontal / Horizontale Türschiene				4	
50	11376	Diagonal Door Brace / Renfort diagonal de porte / Abrazadera diagonal de la puerta / Diagonale Türversteifung				4	
51	11377	Door Handle Brace / Renfort de poignée de porte / Abrazadera de la manija de la puerta gablete / Türgriffversteifung				2	
52	11378	Door Trim / Garniture de porte / Moldura de la puerta / Türverkleidung				2	
53	11379	Astragal / Astragale de porte / Astrágalo de puerta / Türfugenprofil				1	
54	80229	Door Panel Hinge Side / Coté charnière du panneau de porte / Panel de puerta lateral de bisagra / Türverkleidung Bandseite				1	
55	69835	Edge Trim(Green) / Garniture de bordure (verte) / Contramarco del gablete de (verde) / Kantenschutz (Grün)				4	
56	11362	Side Floor Frame / latéral Cadre de plancher / Tirante del entramado del piso lateral / Seitenbodenrahmen				4	
57	11448	Floor Frame Extension / Extension de cadre de plancher / Extensión del marco de piso / Bodenrahmenverlängerung				2	
58	11449	Wall Channel Extension / Extension de rainure murale / Extensión del canal de pared / Wandkanalverlängerung				2	
59	11451	Roof Beam Extension / Extension de poutre de toiture / Extensión de viga para el techo / Dachträgerverlängerung				6	

ASSEMBLY BY KEY NO.

PIÈCES PAR N° DE REPÈRE

EN,FR,SP,GE-10MC

MONTAJE POR N.º DE REFERENCIA MONTAGE NACH LFD. NR.

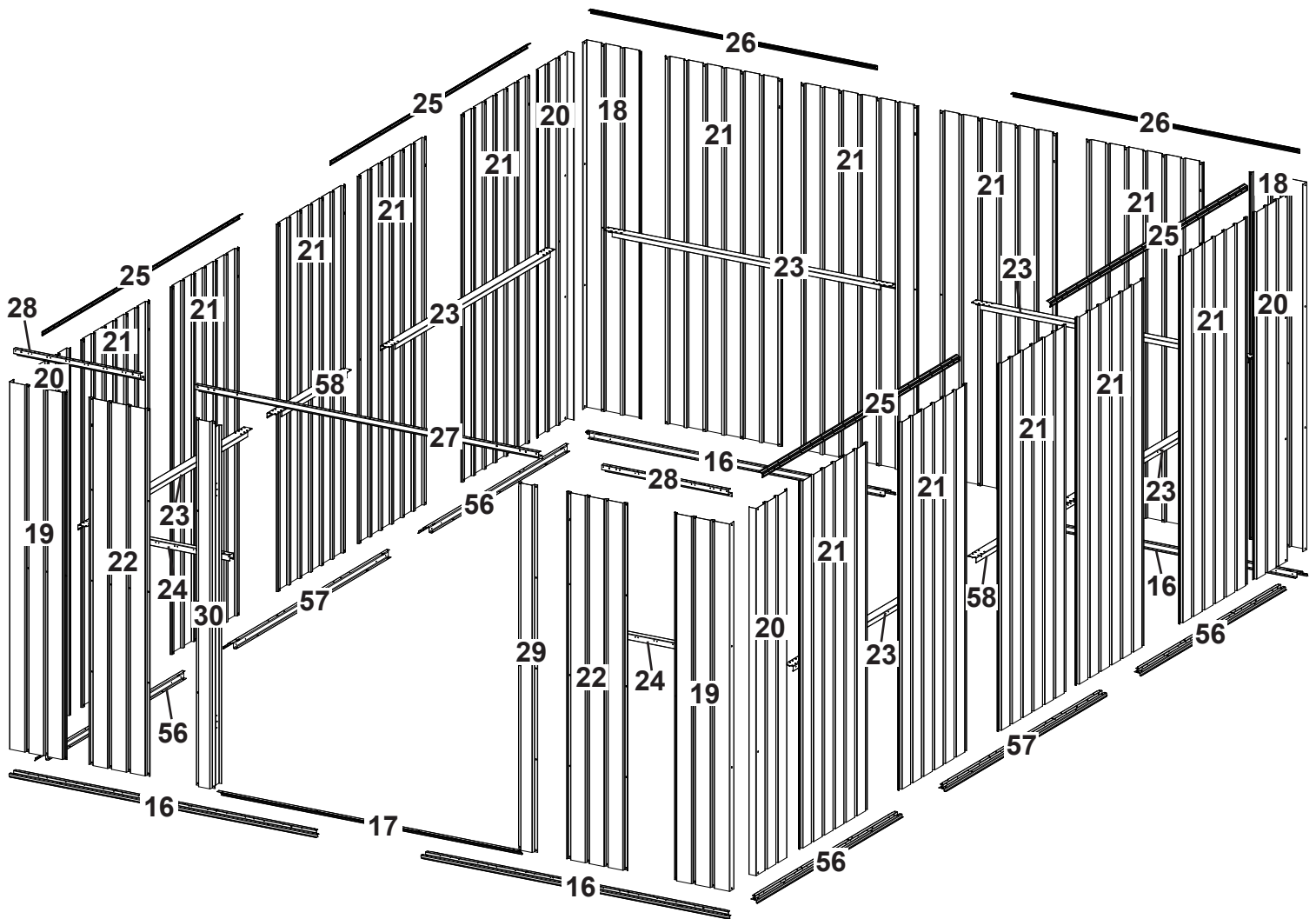

ASSEMBLY BY KEY NO.

PIÈCES PAR N° DE REPÈRE

EN,FR,SP,GE-11Mca

MONTAJE POR N.º DE REFERENCIA MONTAGE NACH LFD. NR.

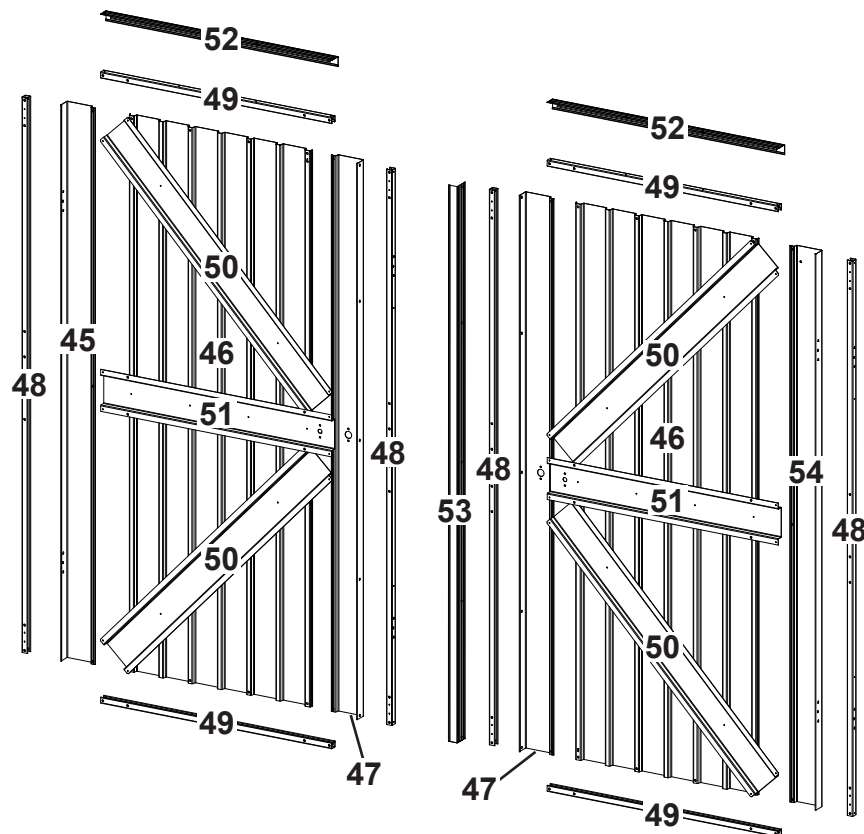
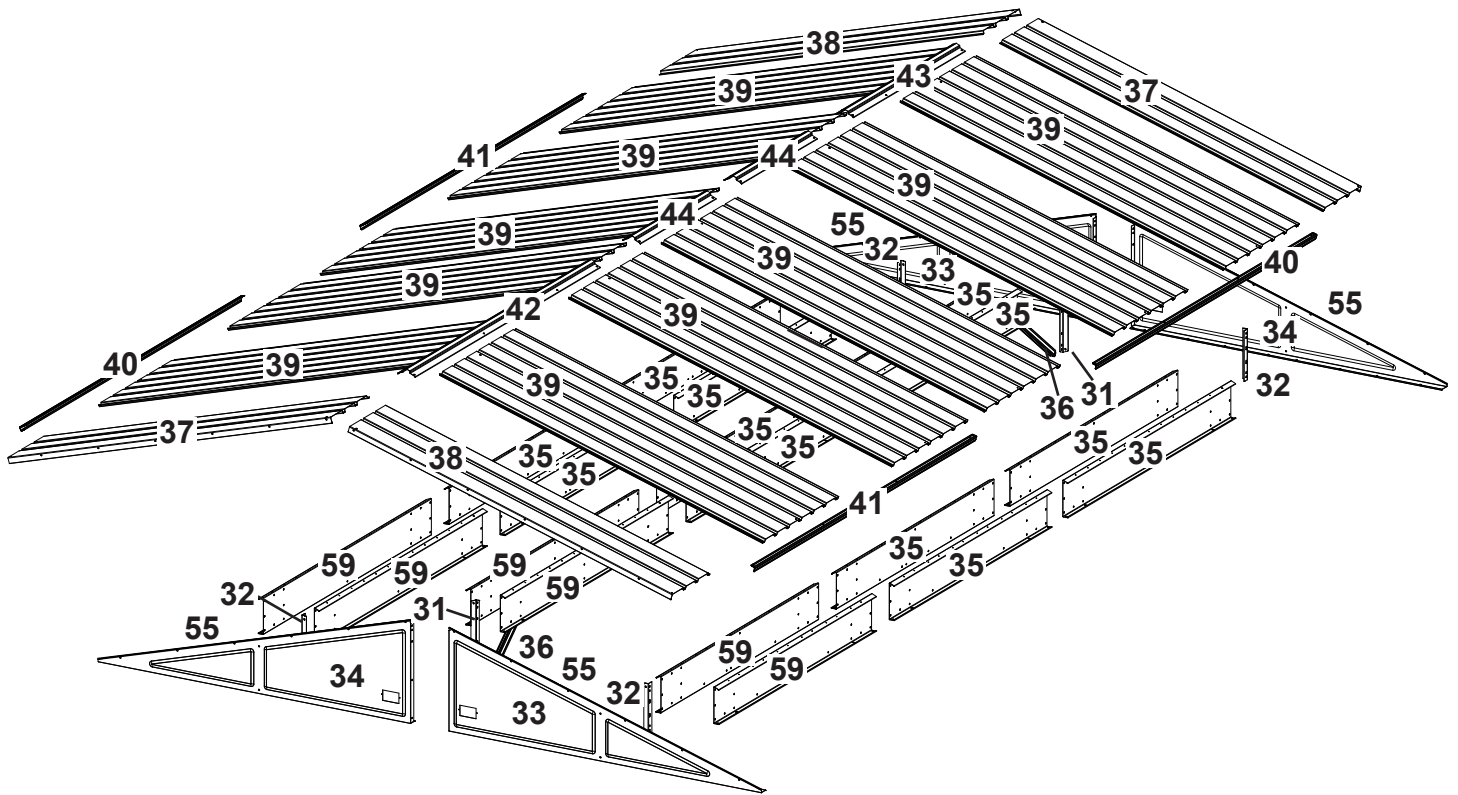

Wood Platform / Plateforme en bois

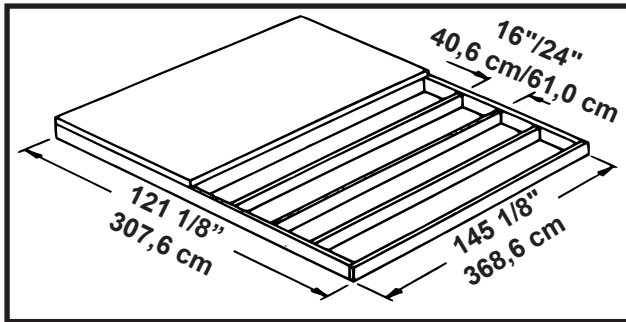

Concrete Slab / Dalle en béton

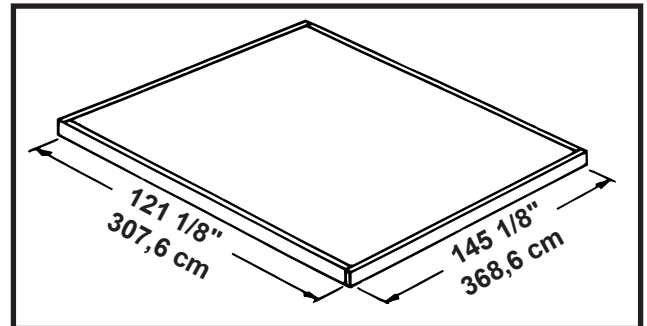

* IMPORTANT *

The base **MUST** be flat and level to provide adequate support for your building, otherwise the **PRE-DRILLED HOLES WILL NOT ALIGN AND IT CANNOT BE ASSEMBLED**. No matter which of the options below you choose for a base, an **ARROW ANCHORING KIT** is recommended as an effective method of properly securing your building after assembly is complete.

OPTION 1: Build directly on the ground

OPTION 2: Wood Platform

NOTE: Pressure Treated Lumber must **NOT** be used where it will make contact with your storage building. The properties of Pressure Treated Lumber will cause accelerated corrosion. **If Pressure Treated Lumber comes in contact with your storage building your warranty will be voided.** The platform should be level and flat (free of bumps, ridges, etc.) to provide good support for the building. The necessary materials may be obtained from your local lumber yard.

OPTION 3: Concrete Slab

The slab should be at least **4" (10,2 cm)** thick.

* IMPORTANT *

La base **DOIT** être plate et de niveau pour fournir un support adéquat à votre bâtiment, sinon les trous **PRÉ-PERCÉS NE S'ALIGNERONT PAS ET ILS NE POURRONT PAS ÊTRE ASSEMBLÉS**. Quelque que soit l'option ci-dessous choisie pour la base, un **NÉCESSAIRE D'ANCRAGE ARROW** est recommandé pour amarrer solidement l'abri une fois que le montage est terminé.

OPTION 1 : Construire à même le sol

OPTION 2 : Plateforme en bois

REMARQUE : Ne **PAS** utiliser de bois traité sous pression aux points de contact avec l'abri. **Le bois traité sous pression contribue à accélérer la corrosion. Le contact de bois traité sous pression avec l'abri aura pour effet d'annuler la garantie.** La plateforme doit être plate et de niveau (sans bosses, arêtes, etc.) afin d'offrir un bon support à l'abri. Les matériaux nécessaires peuvent s'obtenir auprès d'un fournisseur de bois d'œuvre local.

OPTION 3 : Dalle en béton

La dalle doit avoir au moins **4 "(10,2 cm)** d'épaisseur.

Plataforma de Madera / Plattform aus Holz

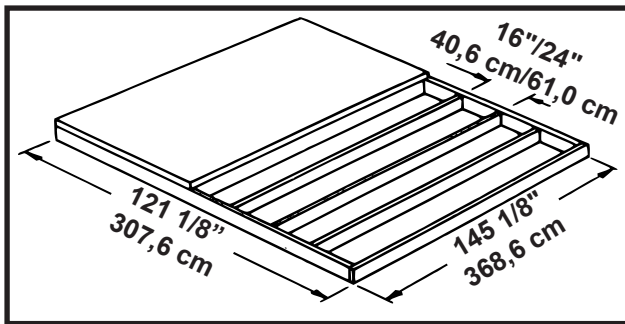

Losa de Hormigón / Bodenplatte aus Beton

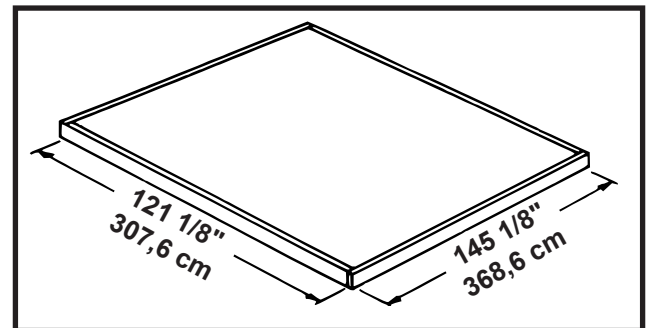

* IMPORTANTE *

La base **DEBE** ser plana y nivelada para proporcionar el soporte adecuado para su edificio; de lo contrario, los **AGUJEROS PRETALADRADOS NO SE ALINEARÁN Y NO SE PUEDEN MONTAR**. Independientemente de las siguientes opciones que elija como base, se recomienda un KIT DE SUJECIÓN ARROW como método eficaz para sujetar adecuadamente su cobertizo después de terminar el ensamblaje.

OPCIÓN 1: Construir directamente en el suelo

OPCIÓN 2: Plataforma de madera

NOTA: La madera tratada a presión **NO** debe usarse donde haga contacto con su edificio de almacenamiento. Las propiedades de la madera tratada a presión causarán corrosión acelerada. **Si la madera tratada a presión entra en contacto con su edificio de almacenamiento, su garantía quedará anulada.** La plataforma debe estar nivelada y plana (libre de golpes, crestas, etc.) para proporcionar un buen soporte para el edificio. Los materiales necesarios se pueden obtener de su aserradero local.

OPCIÓN 3: Losa de hormigón

La losa debe tener **al menos 4 "(10,2 cm)** de espesor.

WICHTIG

Der Sockel **MUSS** flach und eben sein, um eine angemessene Unterstützung für Ihr Gebäude zu gewährleisten. Andernfalls werden die **VORGEBOHRTEN LÖCHER NICHT AUSGERICHTET UND ES KANN NICHT ZUSAMMENGEBAUT WERDEN**. Unabhängig davon, für welche der nachfolgend genannten Möglichkeiten Sie sich als Fundament entscheiden, empfiehlt sich ein ARROW-VERANKERUNGSKIT als wirkungsvolle Methode zur ordnungsgemäßen Sicherung Ihres Bauwerks nach Abschluss der Montagearbeiten.

MÖGLICHKEIT 1: Direkt auf dem Untergrund (Erde)

MÖGLICHKEIT 2: Plattform aus Holz

HINWEIS: An Stellen, an denen es mit Ihrem Geräteschuppen in Kontakt kommen würde, darf **kein** kesseldruckimprägniertes Holz verwendet werden. Kesseldruckimprägniertes Holz hat Eigenschaften, die zu beschleunigter Korrosion führen. **Wenn kesseldruckimprägniertes Holz mit Ihrem Geräteschuppen in Kontakt kommt, wird Ihre Garantie ungültig.**

MÖGLICHKEIT 3: Bodenplatte aus Beton

Die Bodenplatte sollte **wenigstens 10,2 cm** stark sein.

1: FLOOR FRAME

CADRE DE PLANCHER
MARCO DE PISO

BODENRAHMEN

EN,FR,SP,GE-14MC

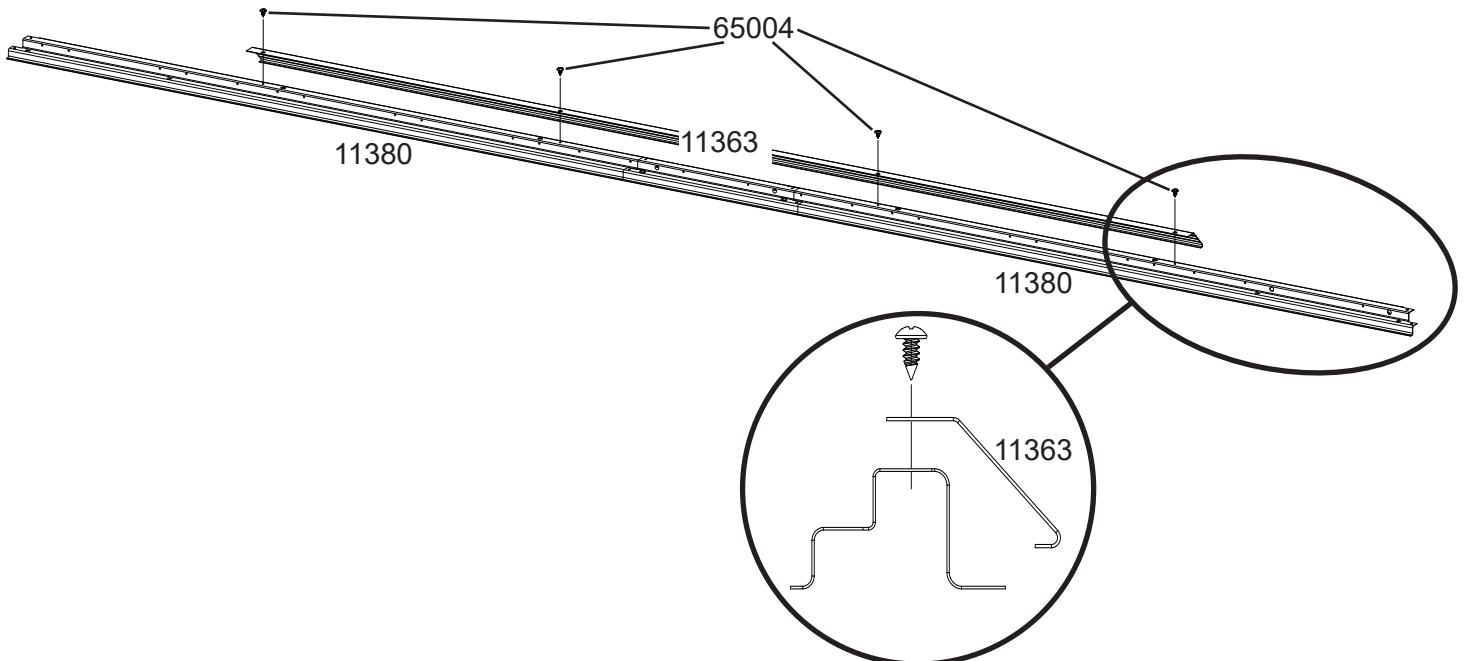
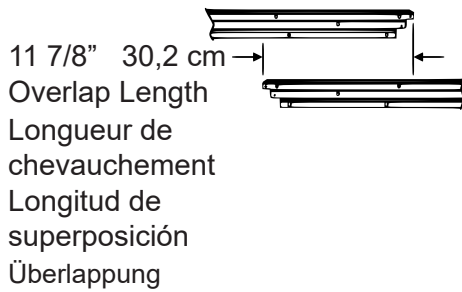
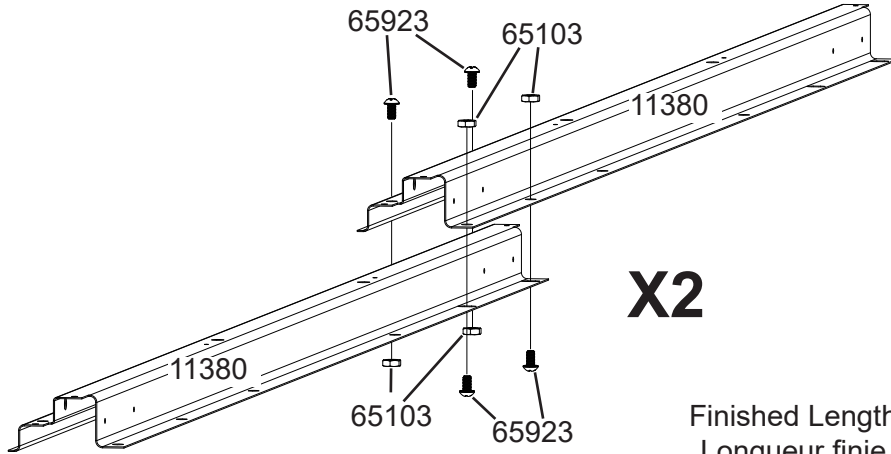
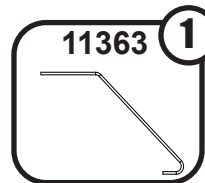
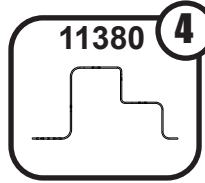
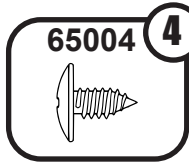
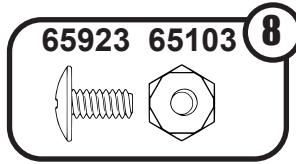

Side View Vue latérale Vista lateral Seitenansicht

1: FLOOR FRAME

CADRE DE PLANCHER
MARCO DE PISO

BODENRAHMEN

EN,FR,SP,GE-15MC

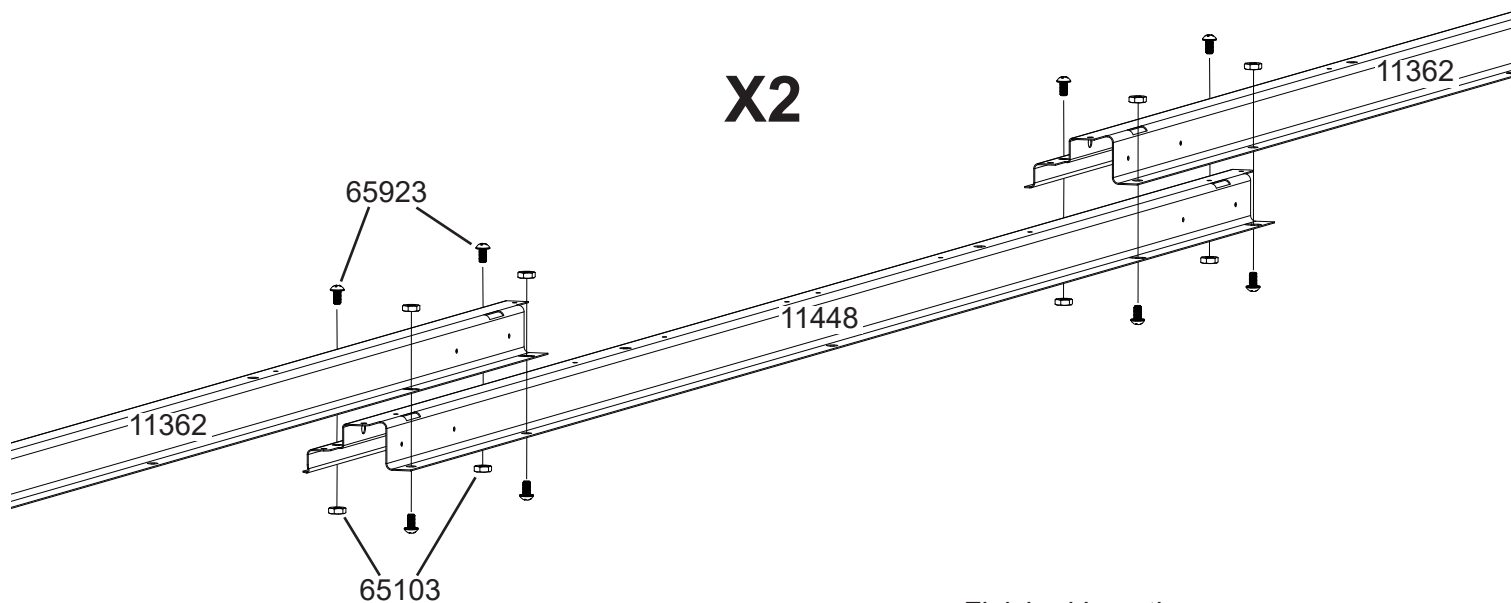
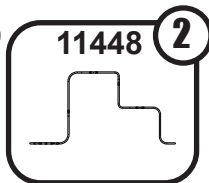
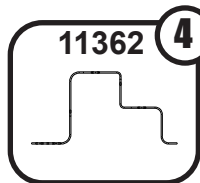
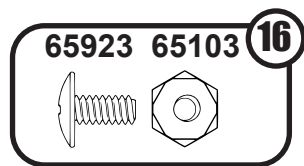

11 7/8" 30,2 cm
Overlap Length
Longueur de
chevauchement
Longitud de
superposición
Überlappung

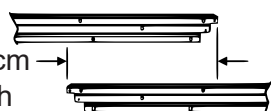

Finished Length
Longueur finie
Longitud terminada
Länge nach Montage

143 1/2" 364,5 cm

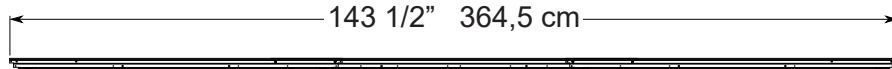

1: FLOOR FRAME

CADRE DE PLANCHER
MARCO DE PISO BODENRAHMEN

EN,FR,SP,GE-16MC

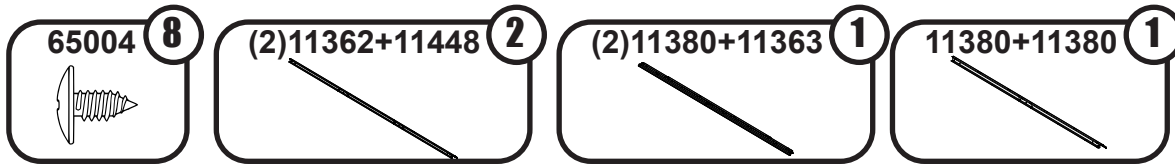

NOTES:

Do NOT fasten your Floor Frames to your Base at this time. You will anchor your building after it is erected.

The Floor Frame must be BOTH square AND level or the holes will not line up properly.

Measure diagonally from corner to corner. When diagonal measurements are equal, the Frame is square.

REMARQUES:

Ne PAS attacher les éléments de cadre de plancher à la base à ce stade. L'abri sera ancré une fois qu'il est assemblé.

Le cadre de plancher doit être À LA FOIS d'équerre et de niveau pour que les trous s'alignent correctement.

Mesurer en diagonale d'un coin à l'autre. Lorsqu'elles sont égales, le cadre de plancher est d'équerre.

NOTAS:

NO fije los tirantes del piso a la base en este momento. Anclará la estructura después de que esté erguida.

El tirante del piso debe estar TANTO cuadrado COMO nivelado o los orificios no se alinearán correctamente.

Mida diagonalmente de esquina a esquina. Cuando las medidas diagonales son iguales, el tirante está cuadrado.

HINWEIS:

Befestigen Sie Ihre Bodenrahmen noch NICHT am Fundament. Sie verankern Ihr Bauwerk erst, nachdem es fertig aufgebaut ist.

Der Bodenrahmen muss SOWOHL rechtwinklig ALS AUCH waagrecht sein. Andernfalls fluchten die Löcher nicht richtig.

Messen Sie diagonal von Ecke zu Ecke. Wenn die diagonalen Abmessungen gleich sind, ist der Rahmen rechtwinklig.

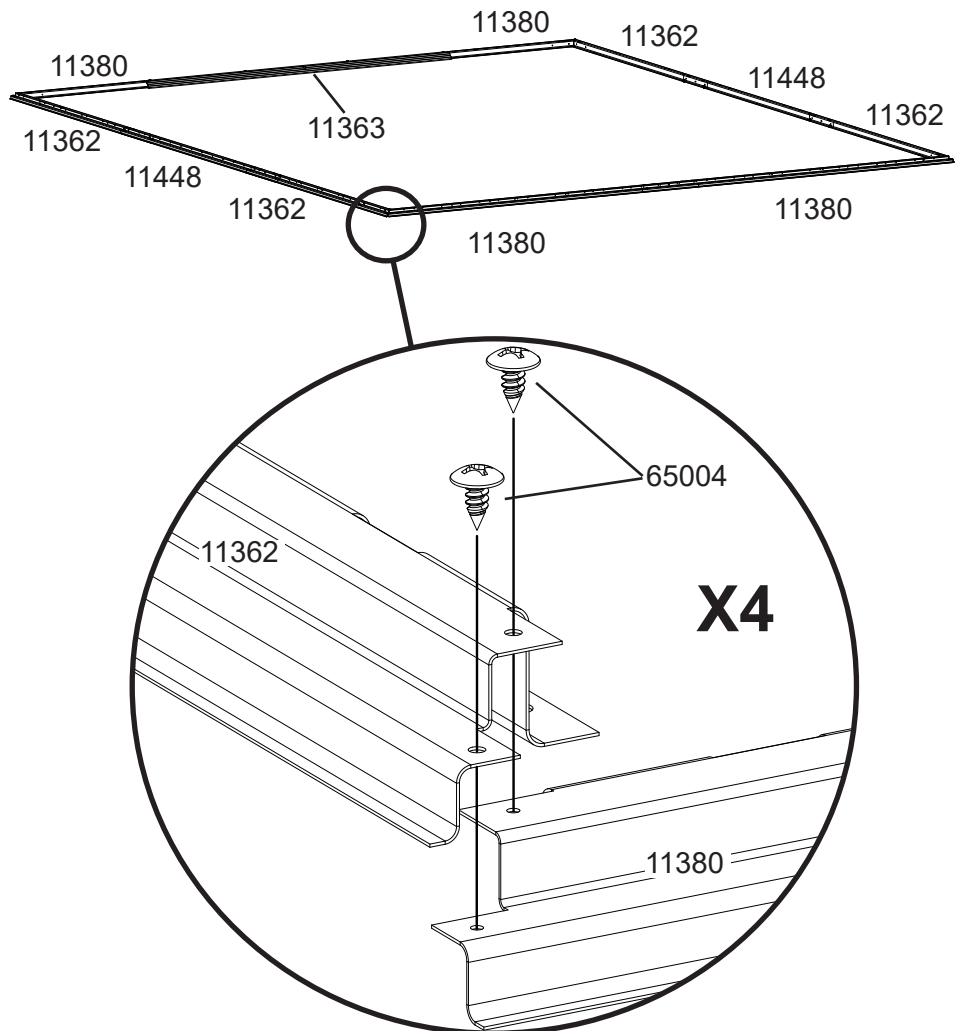

2: PRE-ASSEMBLY

PRÉ-ASSEMBLAGE
PRE-ENSAMBLE VORMONTAGE

EN,FR,SP,GE-17MC

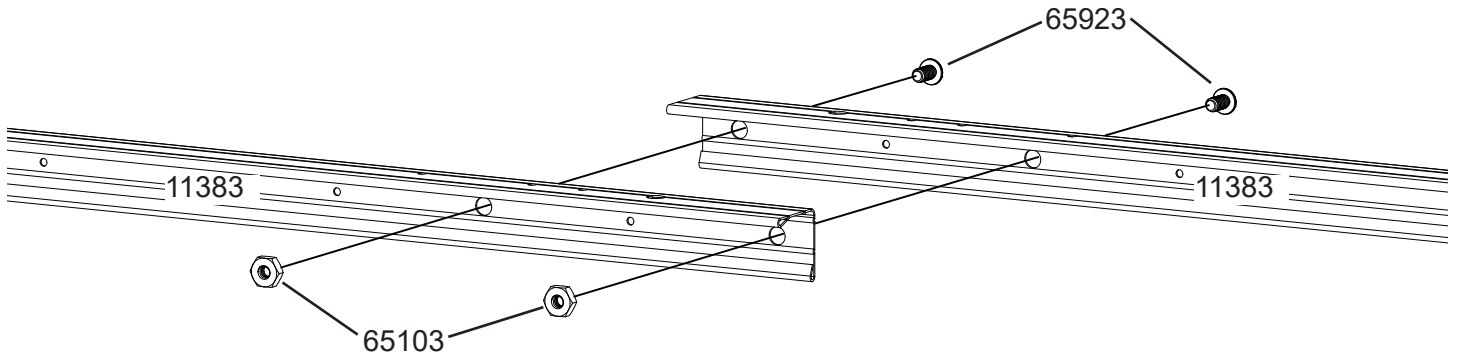
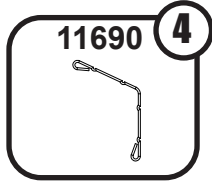
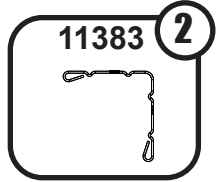
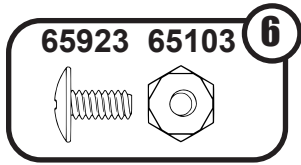

117" (297,2 cm)
Finished Length
Longueur finie
Longitud terminada
Länge nach Montage

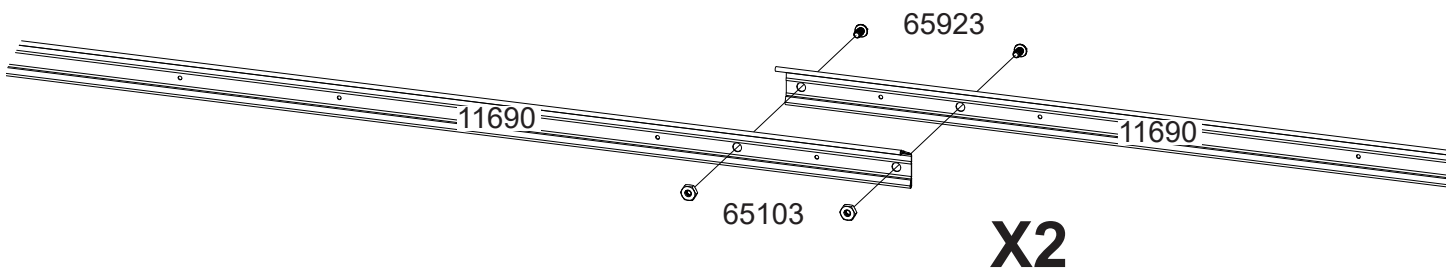

140 3/4" (357,5 cm)
Finished Length
Longueur finie
Longitud terminada
Länge nach Montage

2: PRE-ASSEMBLY

PRÉ-ASSEMBLAGE
PRE-ENSAMBLE VORMONTAGE

EN,FR,SP,GE-18MC

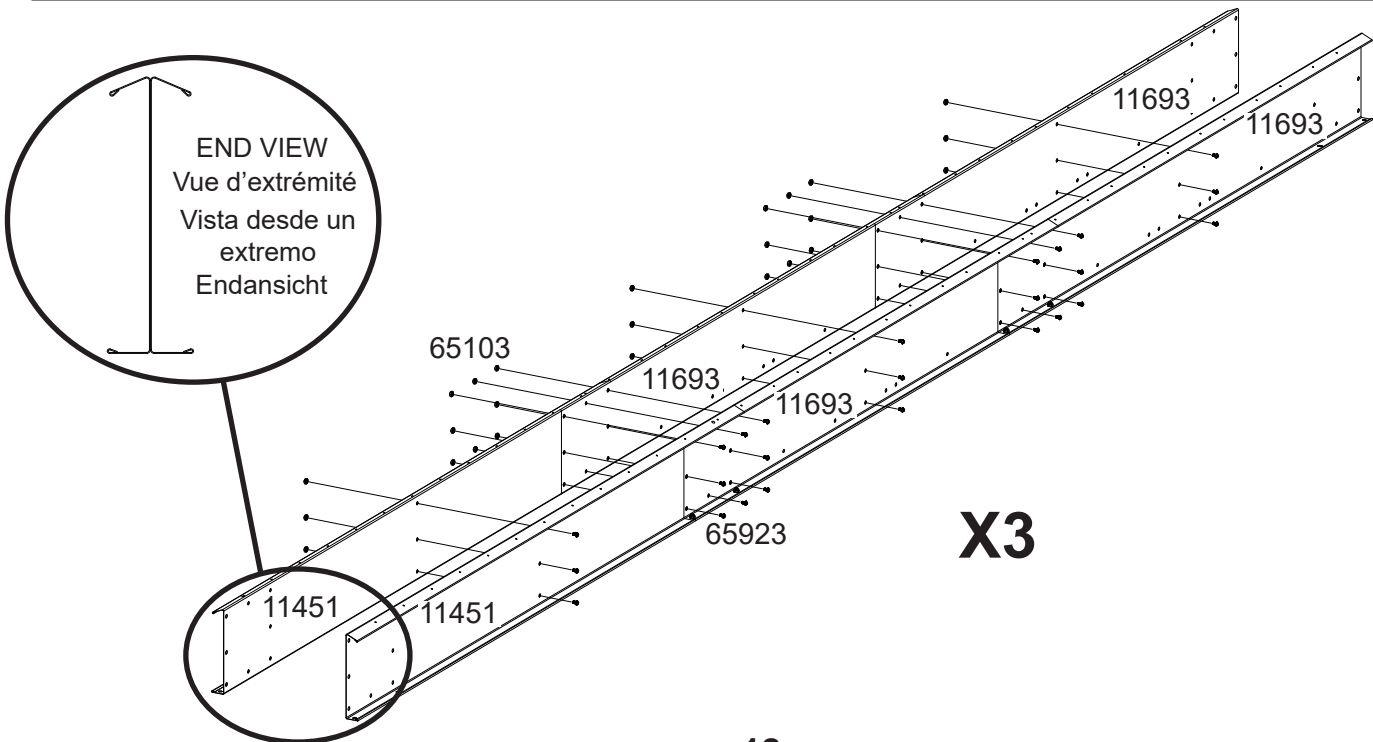
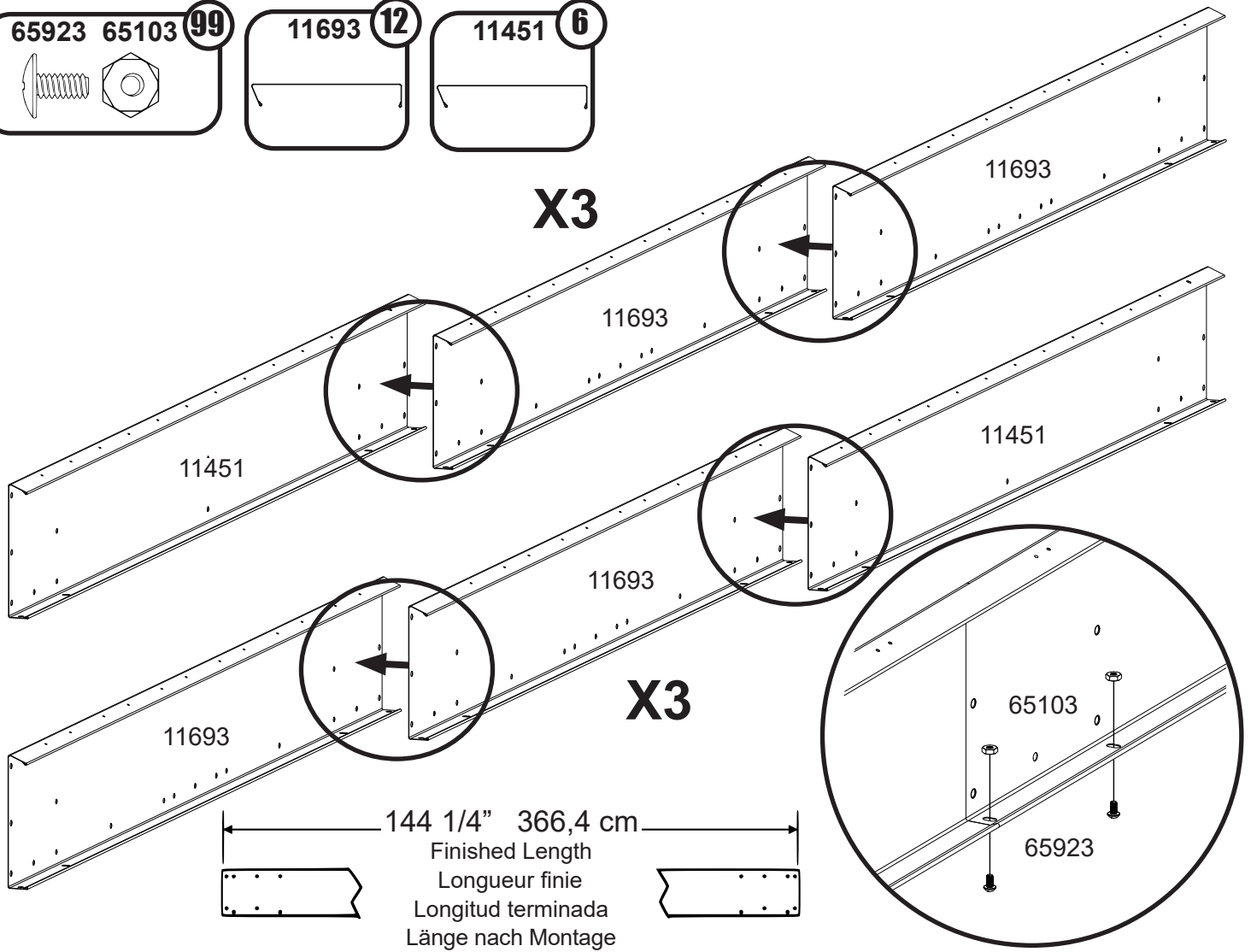
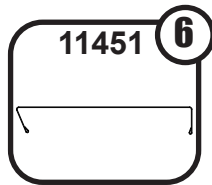
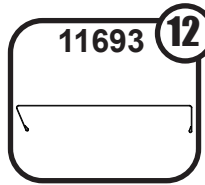
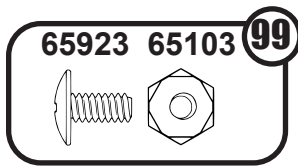

2: PRE-ASSEMBLY

PRÉ-ASSEMBLAGE
PRE-ENSAMBLE VORMONTAGE

EN,FR,SP,GE-19MC

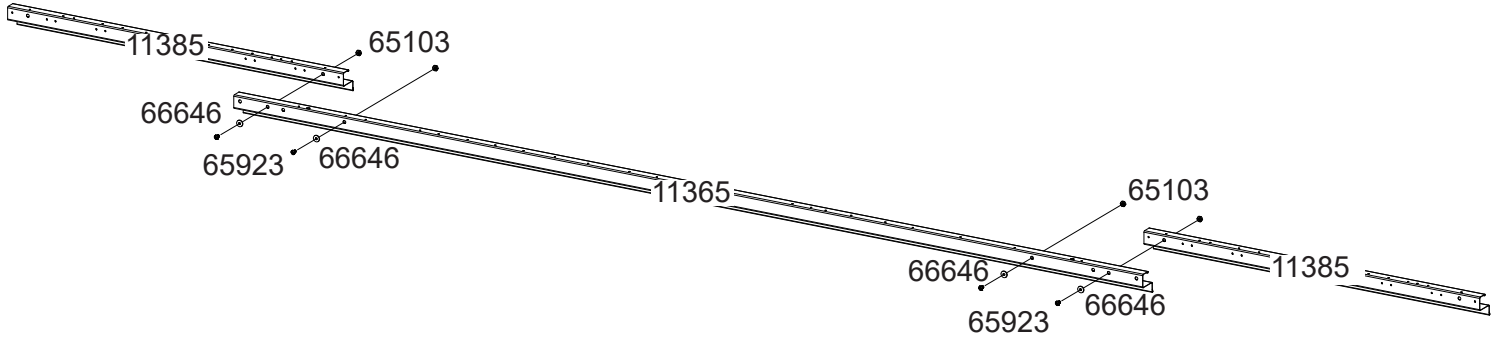
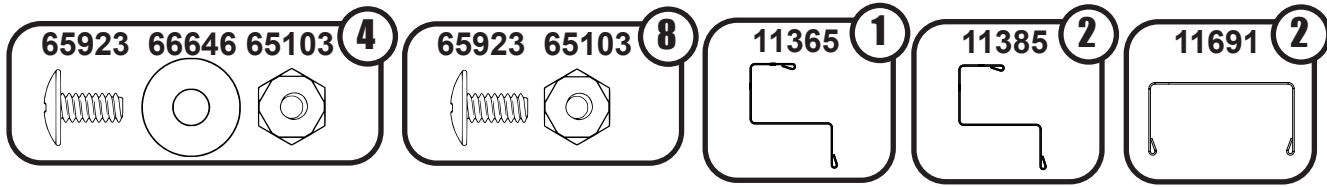

118 1/4" (300,4 cm)
Finished Length
Longueur finie
Longitud terminada
Länge nach Montage

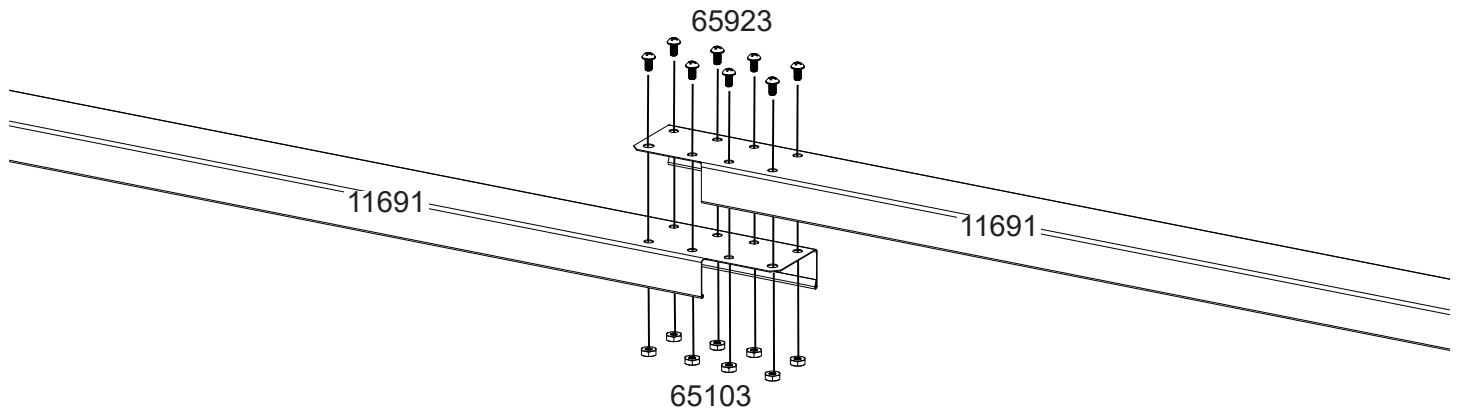

118 1/4" (300,4 cm)
Finished Length
Longueur finie
Longitud terminada
Länge nach Montage

2: PRE-ASSEMBLY

PRÉ-ASSEMBLAGE
PRE-ENSAMBLE VORMONTAGE

EN,FR,SP,GE-20MC

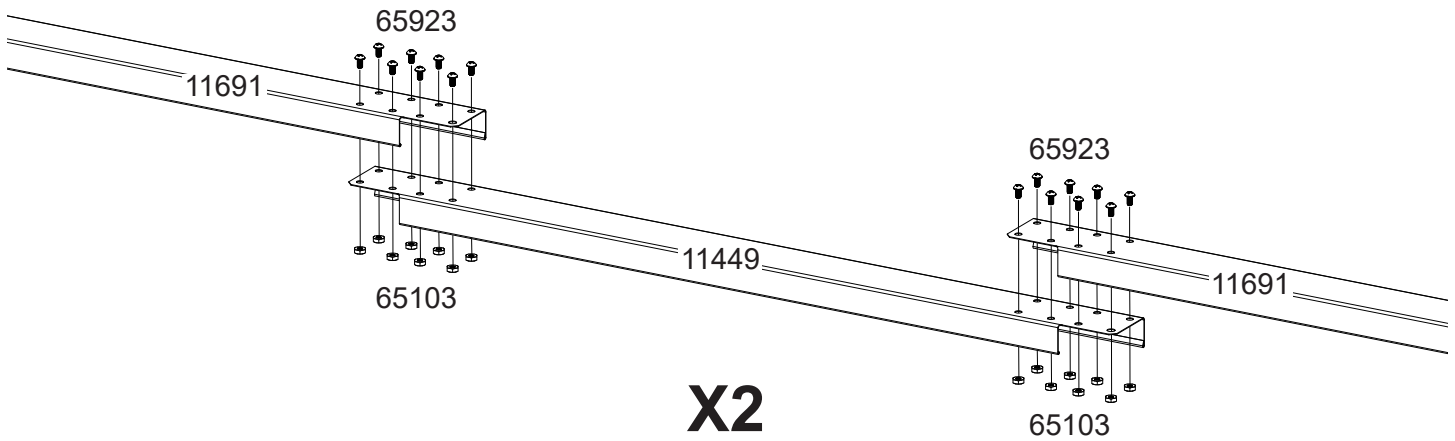
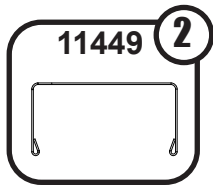
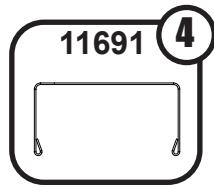
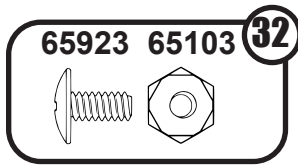

142 1/4" (361,3 cm)
Finished Length
Longueur finie
Longitud terminada
Länge nach Montage

3: CORNER PANELS

PANNEAUX D'ANGLE
PANELES DE ESQUINA ECKPLATTEN

20HU

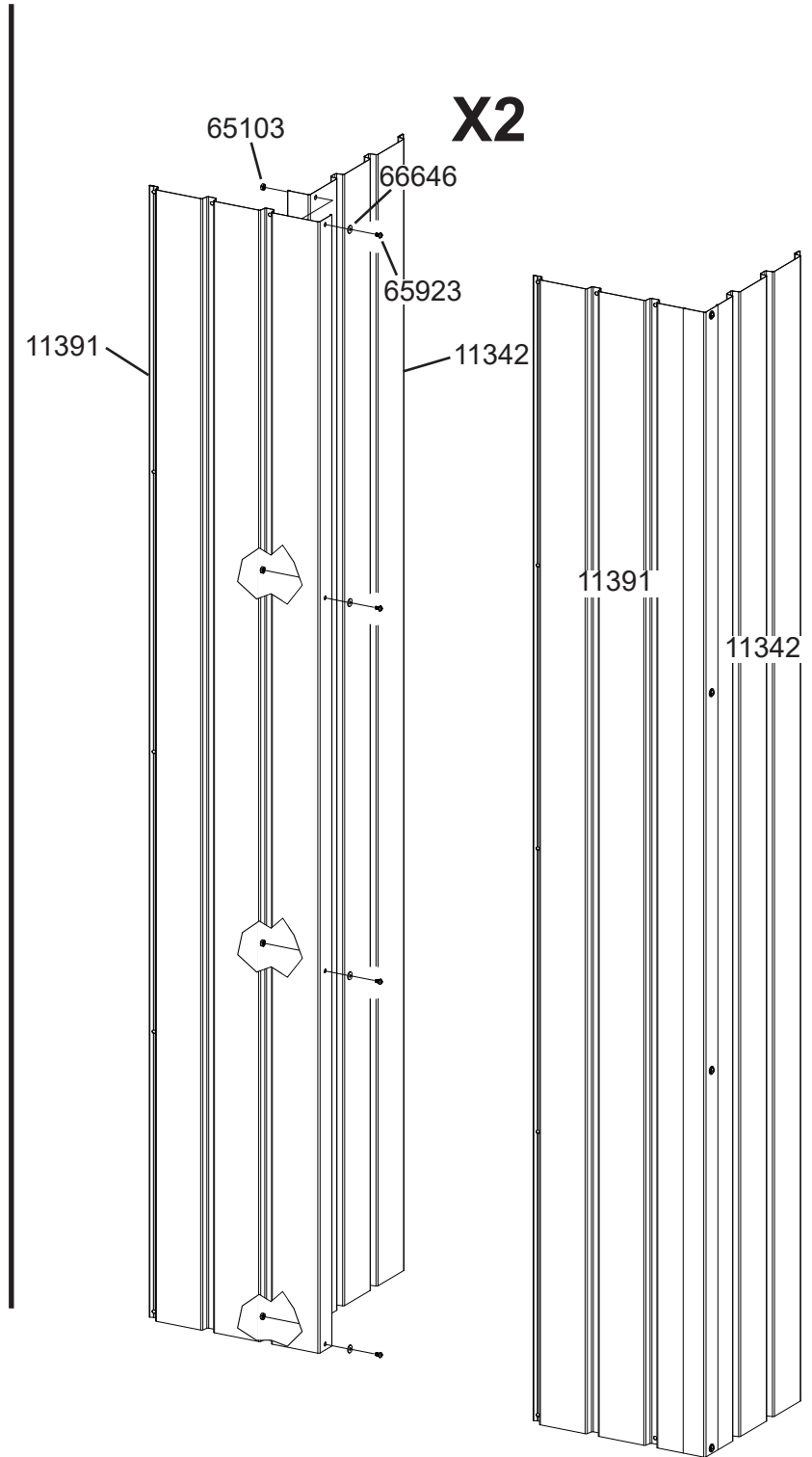
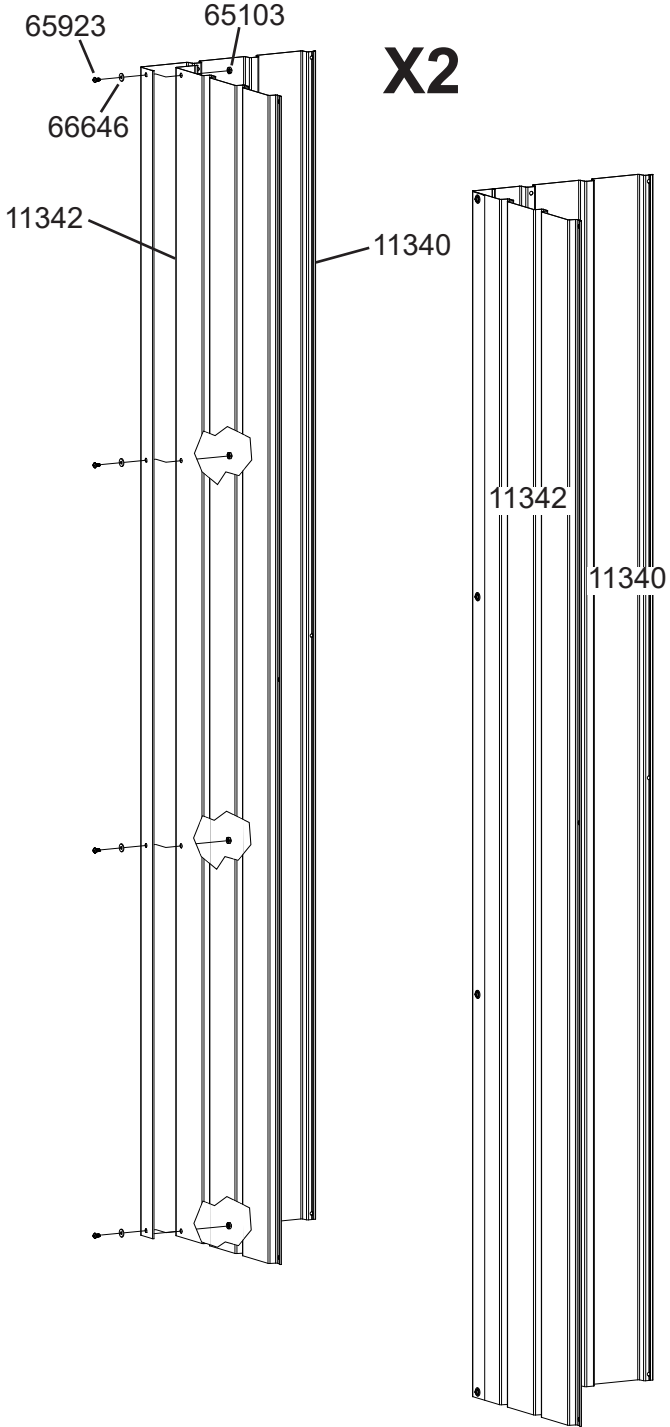
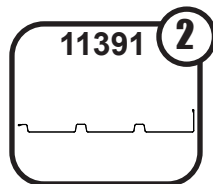
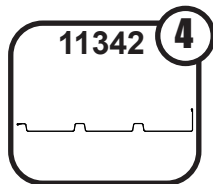
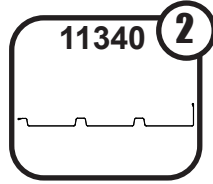
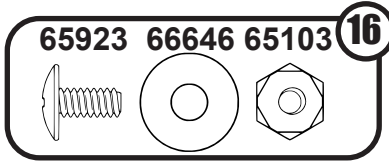

3: CORNER PANELS

PANNEAUX D'ANGLE
PANELES DE ESQUINA ECKPLATTEN

EN,FR,SP,GE-22MC

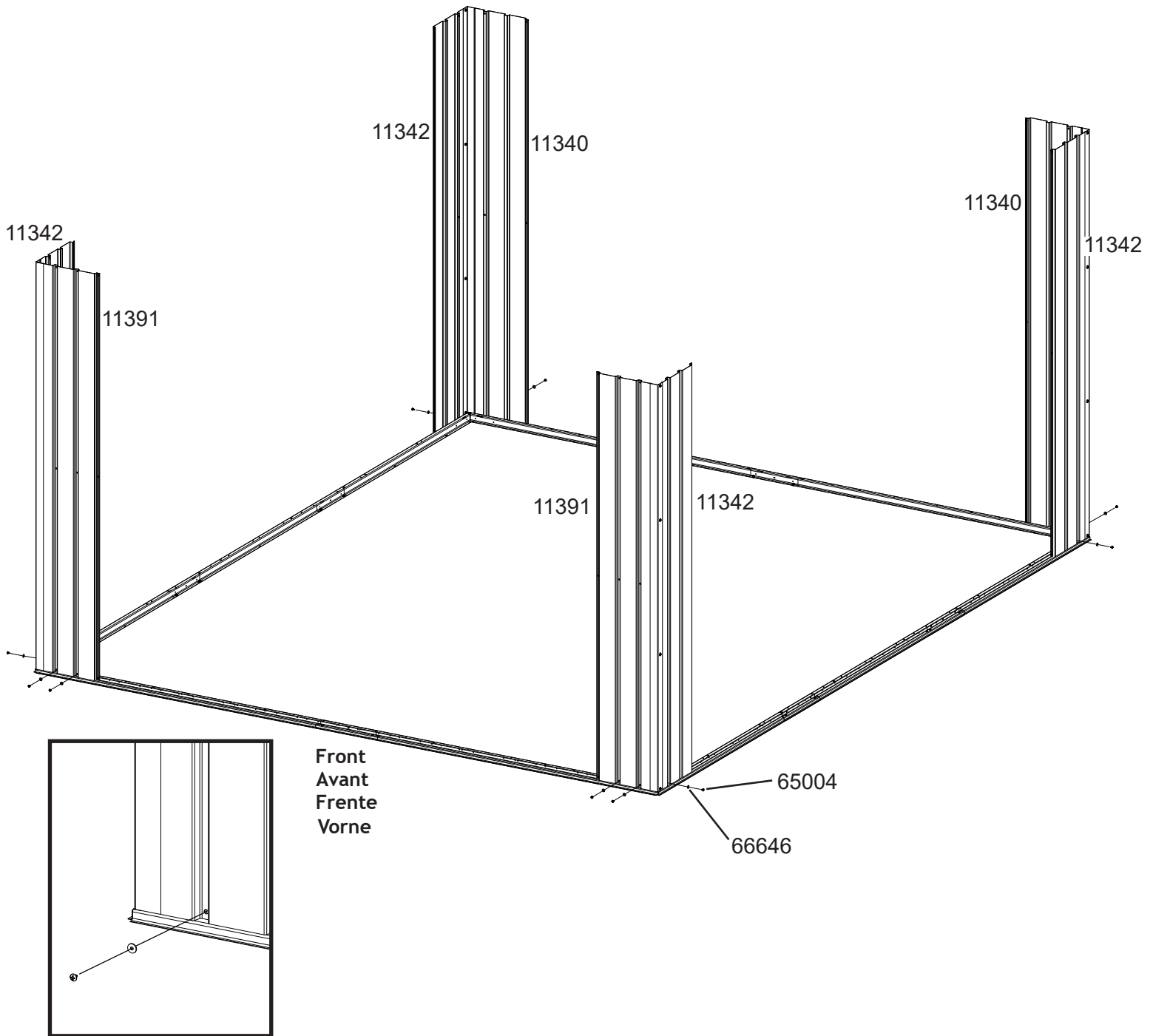
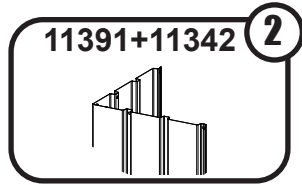
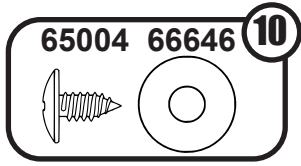

4: WALL ANGLE

CORNIÈRE DE MUR
ÁNGULO DE LA PARED
WANDWINKEL

EN,FR,SP,GE-23MC

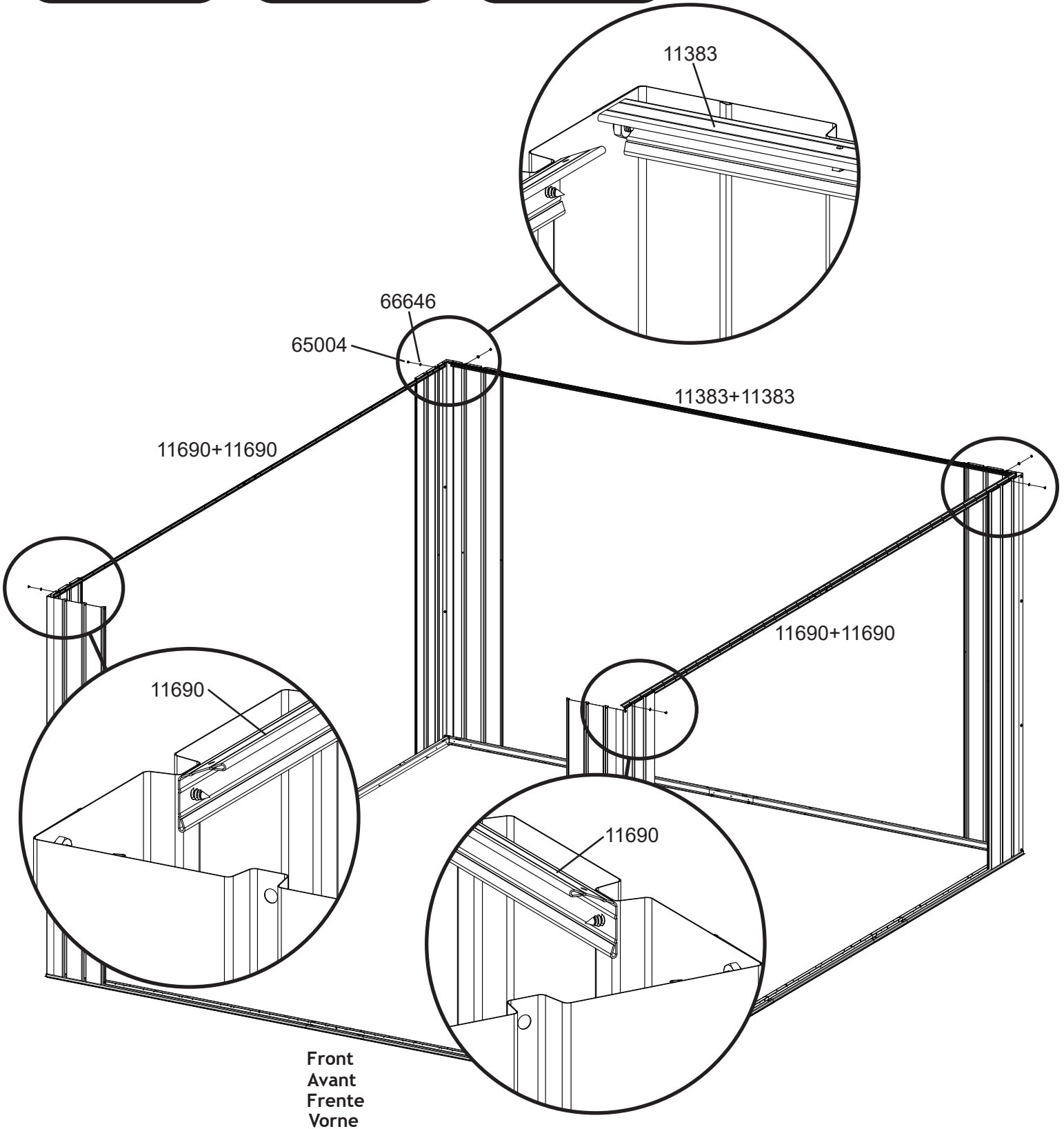
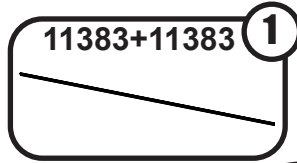
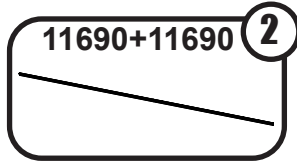
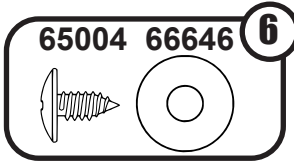

5: LINTEL

LINTEAU
DINTEL STURZ

EN,FR,SP,GE-24MC

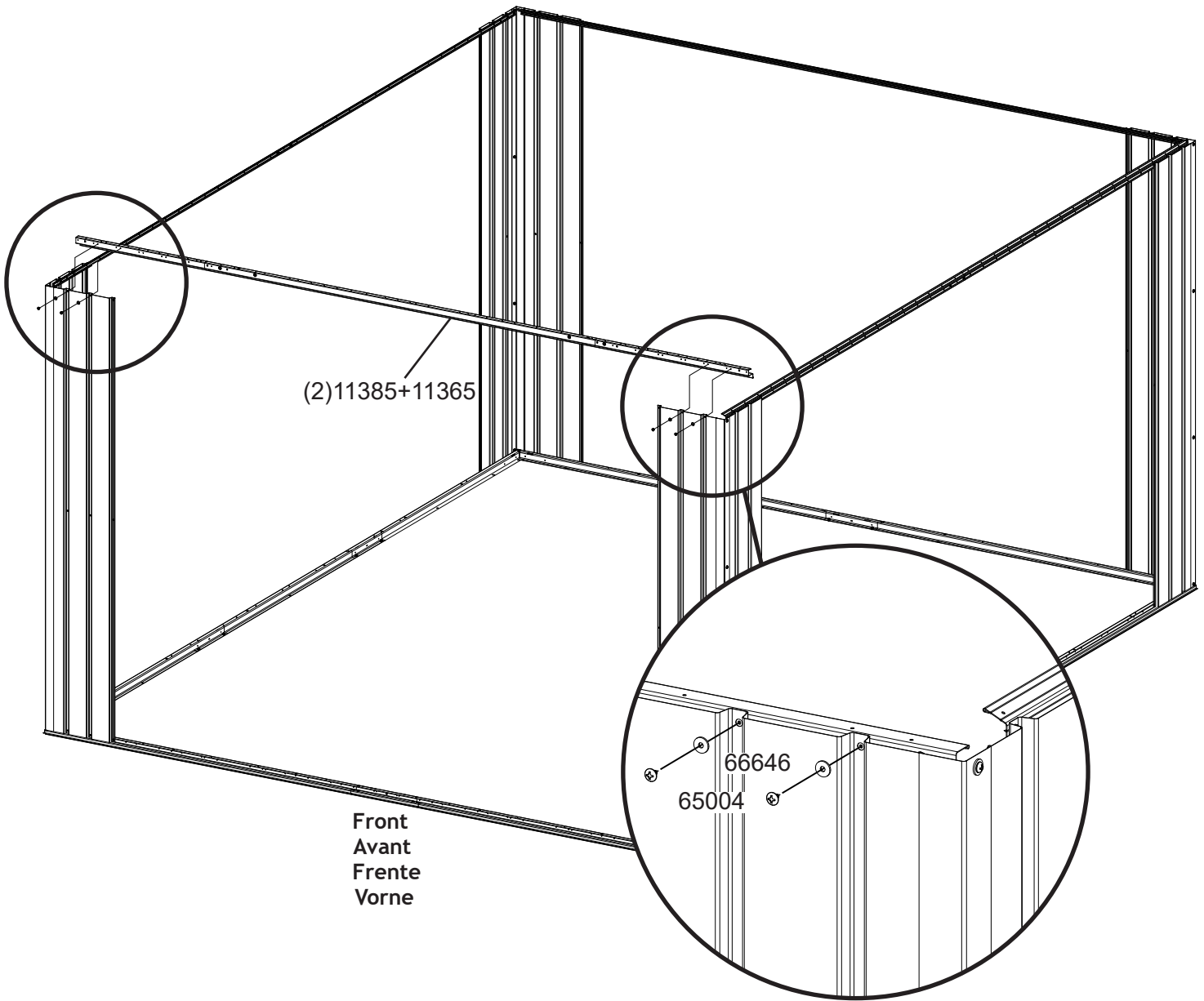
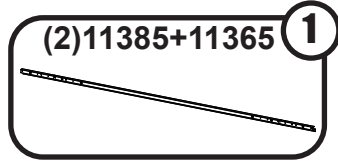
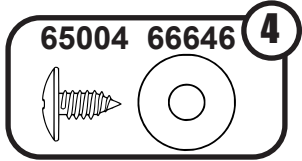

6: WALL CHANNEL

LONGERON DE MUR
CANALETA DE LA PARED WAND VERSTREBUNG

EN,FR,SP,GE-25MC

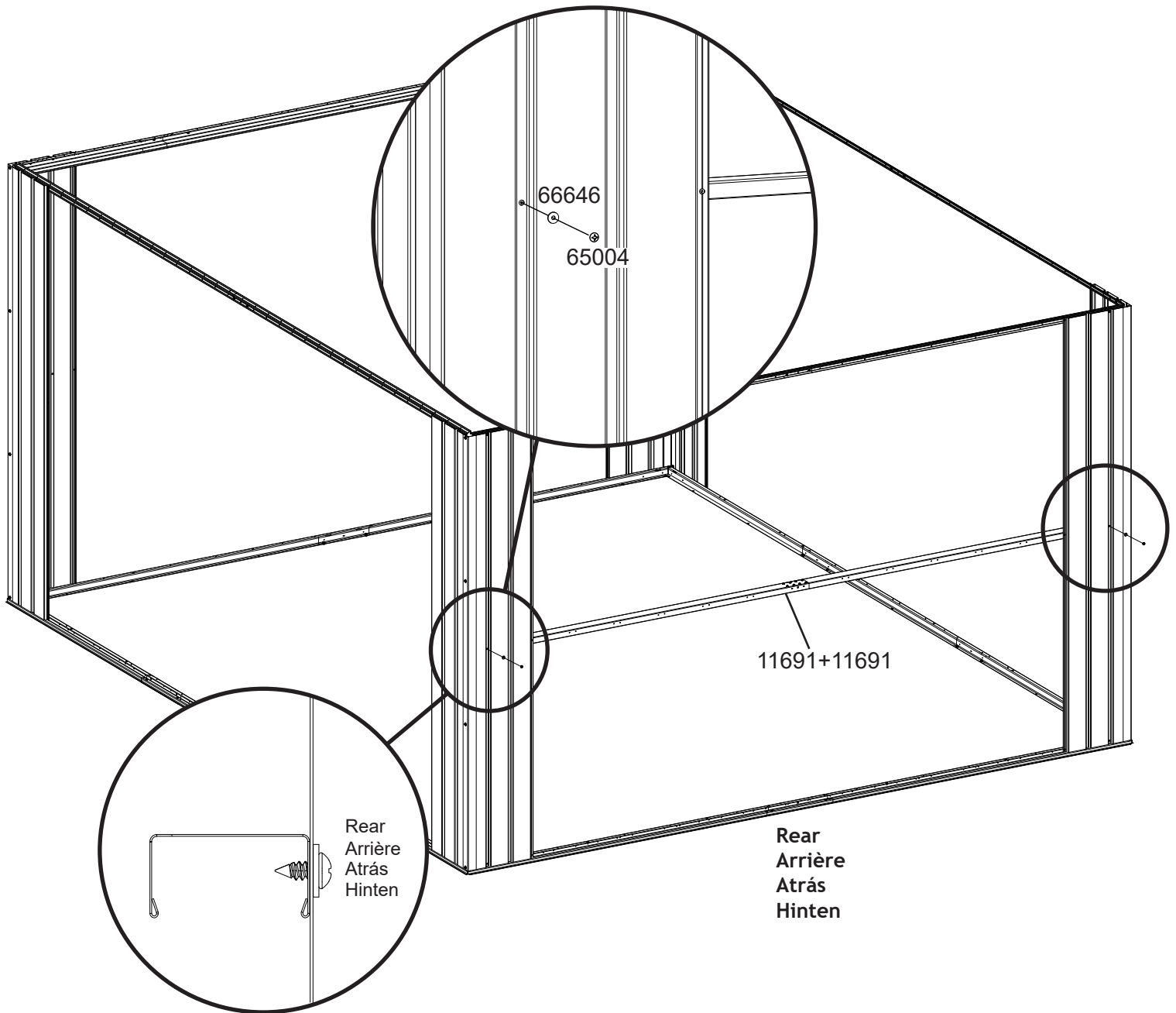
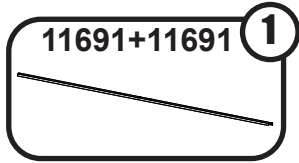
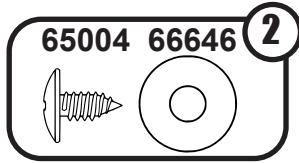

6: WALL CHANNEL

LONGERON DE MUR
CANALETA DE LA PARED WAND VERSTREBUNG

EN,FR,SP,GE-26MC

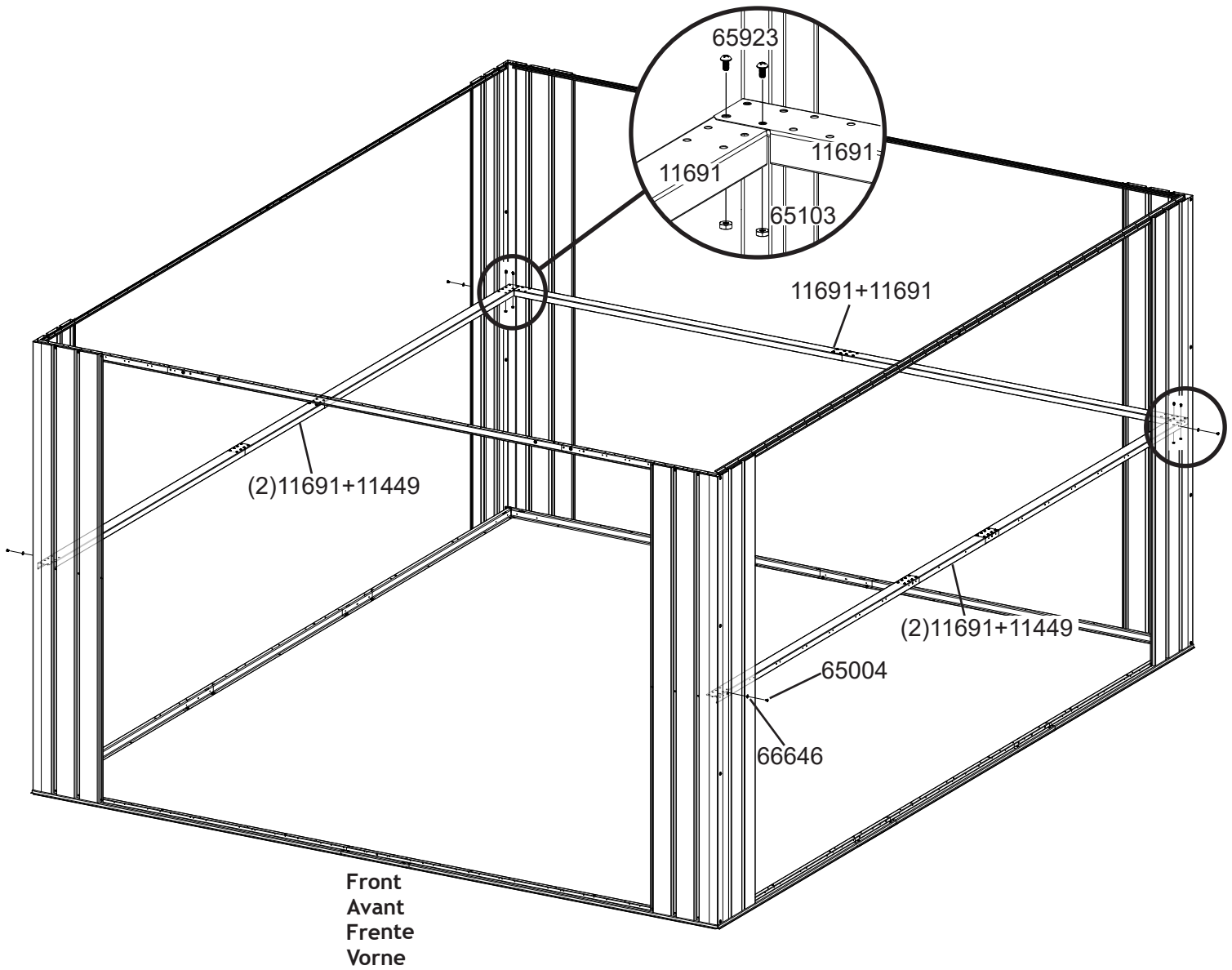
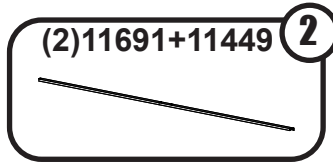
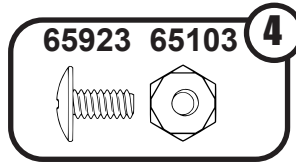
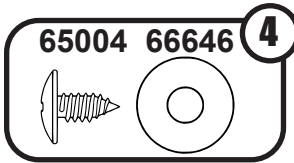

7: WALL PANELS

PANNEAUX DE MUR
PANELES DE LA PARED WANDBLECHE

EN,FR,SP,GE-27MC

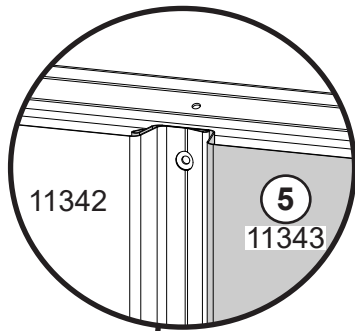
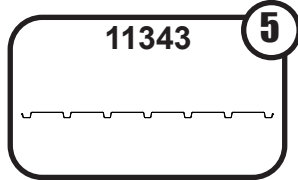
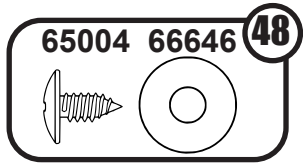

NOTE: ALWAYS COVER THE ARROW
REMARQUE: TOUJOURS COUVRIR LA FLÈCHE
NOTA: DEBE CUBRIRSE SIEMPRE LA FLECHA
HINWEIS: IMMER DEN PFEIL ABDECKEN

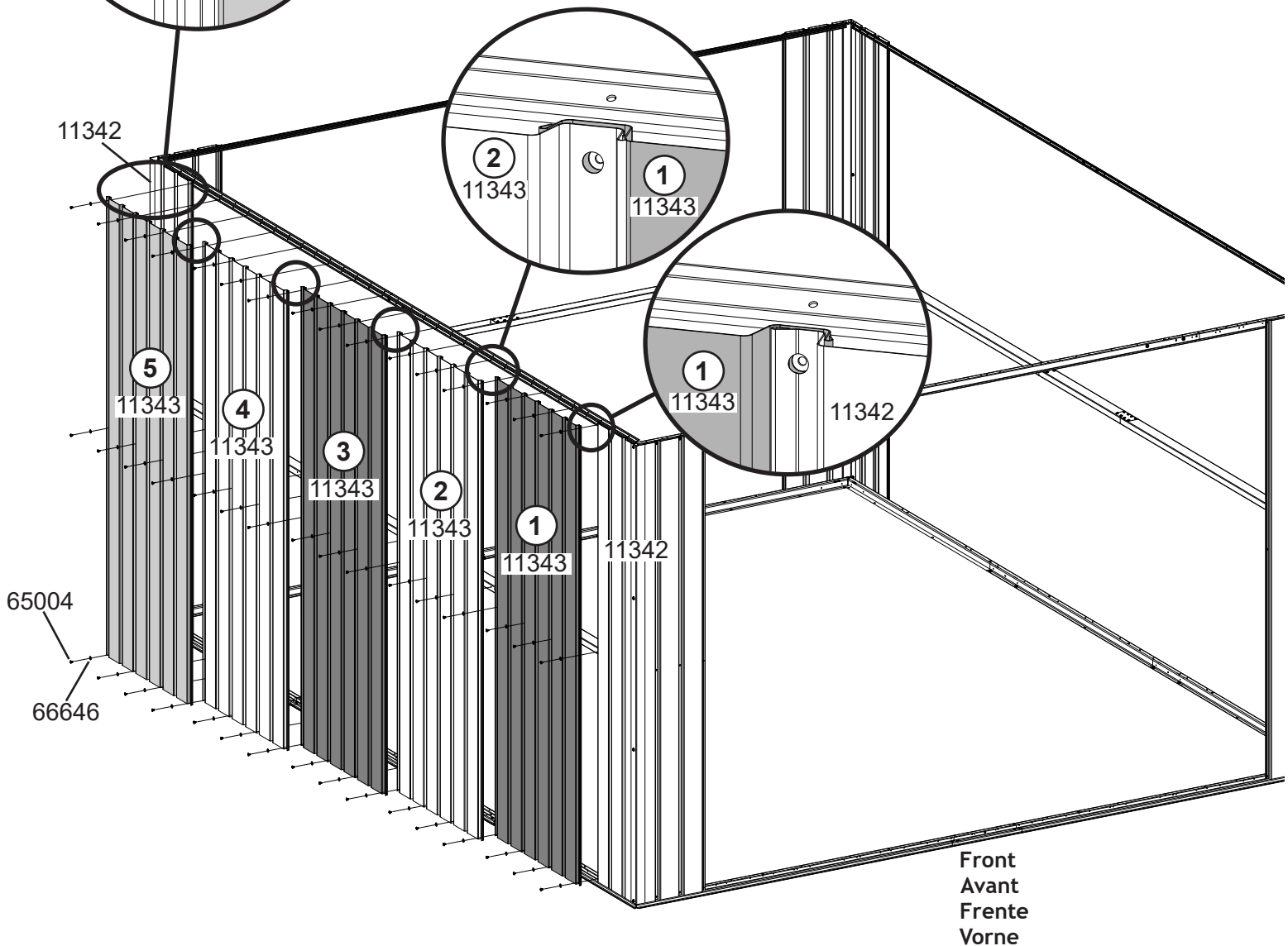
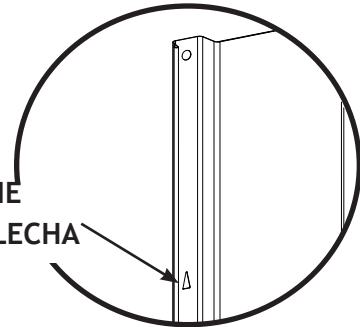

7: WALL PANELS

PANNEAUX DE MUR
PANELES DE LA PARED WANDBLECHE

EN,FR,SP,GE-28MC

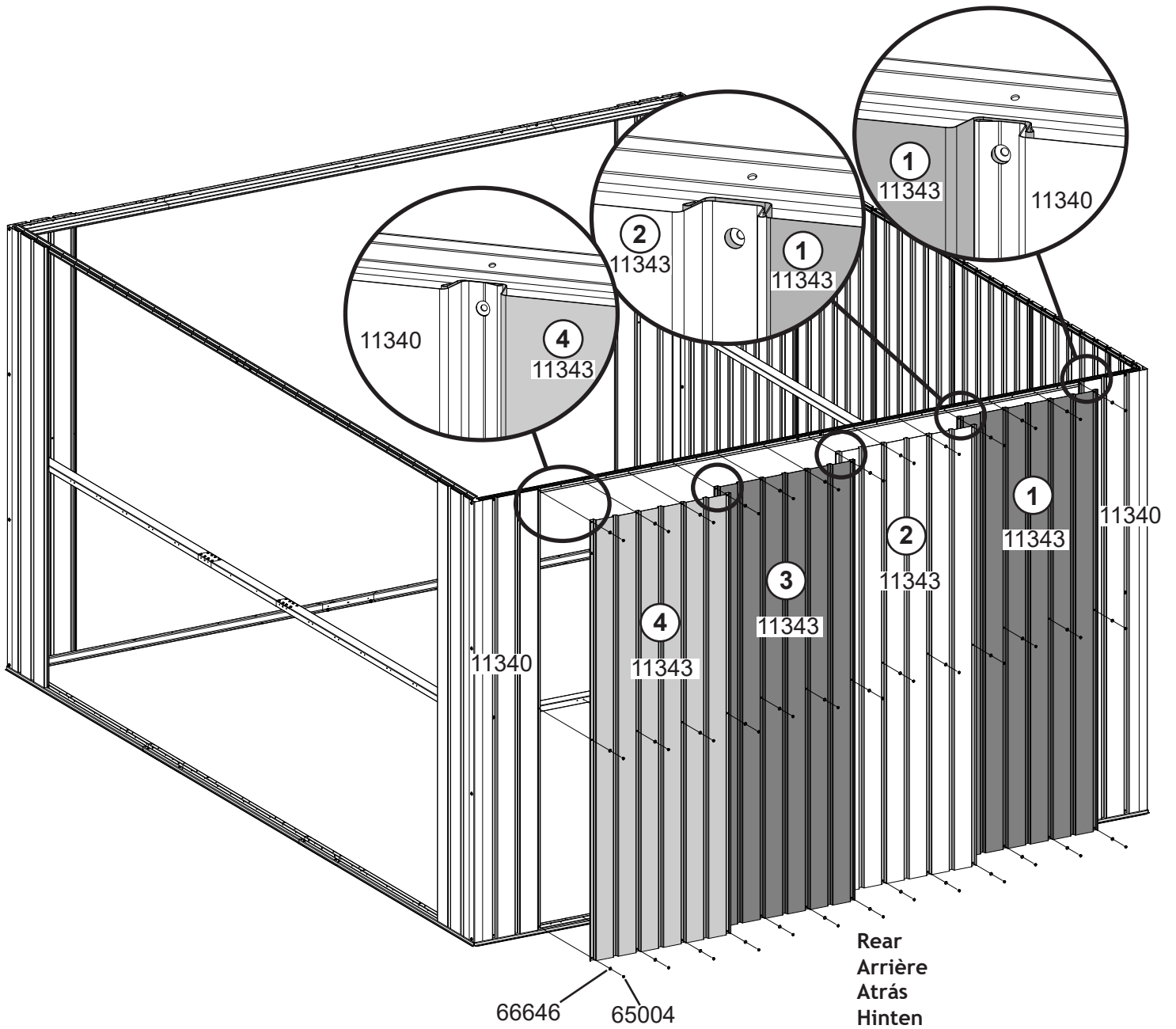
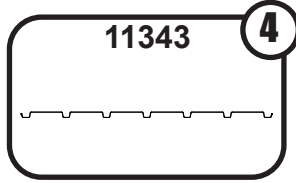
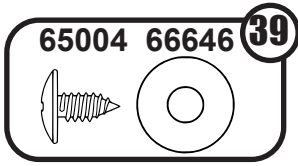

9: WALL CHANNEL FRONT

CANAL MUR AVANT

EN,FR,SP,GE-31MC

CANAL FRONTAL DE PARED VORDERSEITE KANALWAND

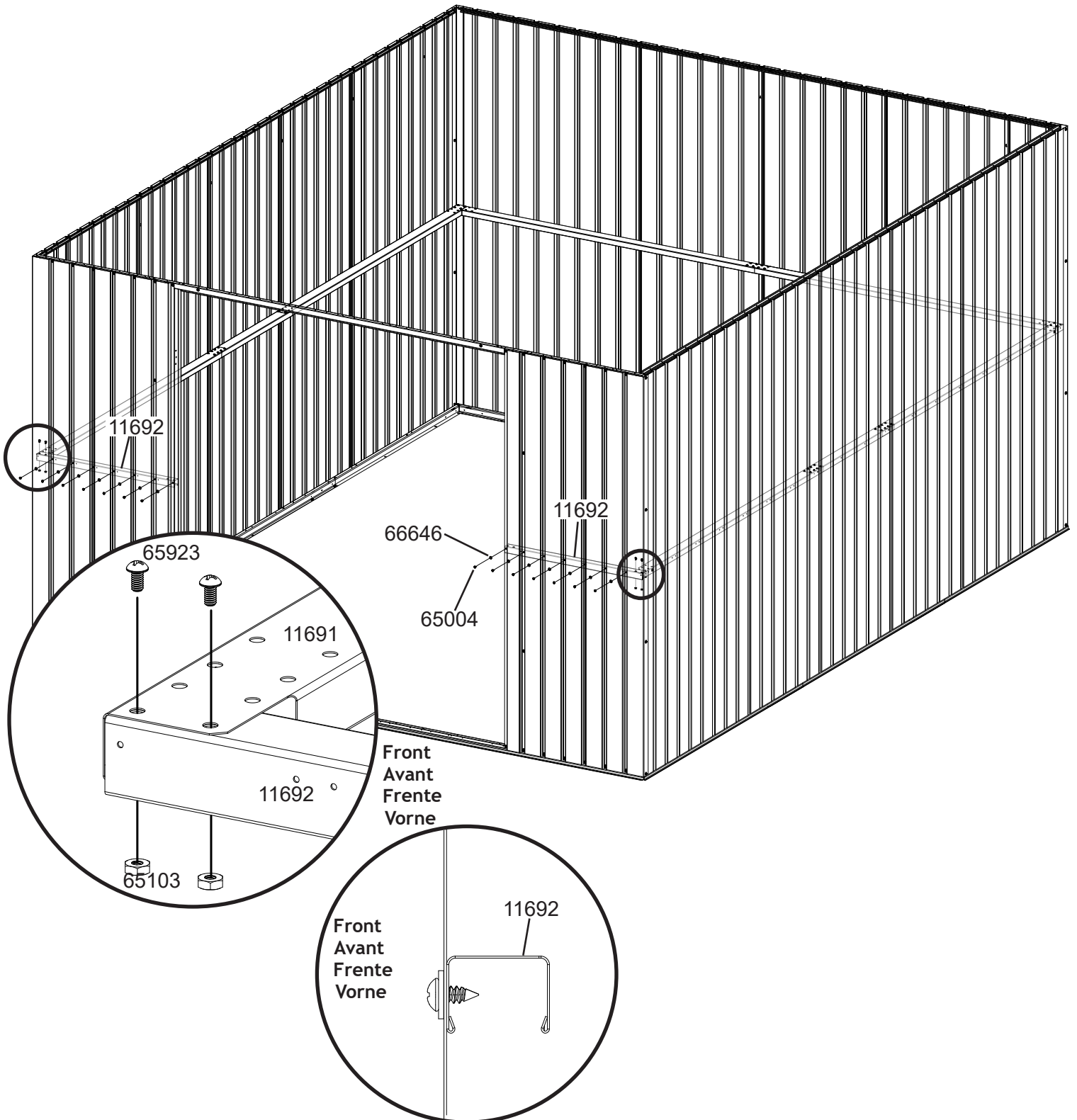
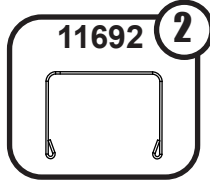
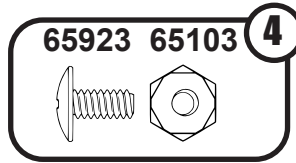
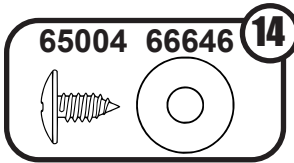

10: GABLES

PIGNON
GABLETE GIEBEL

31HU

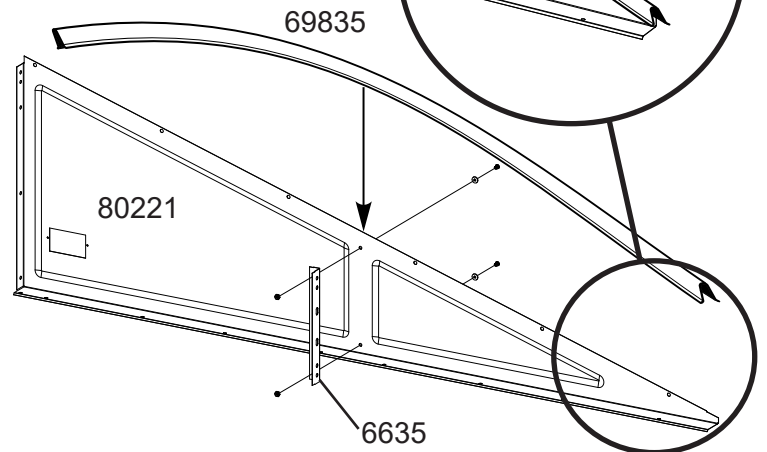
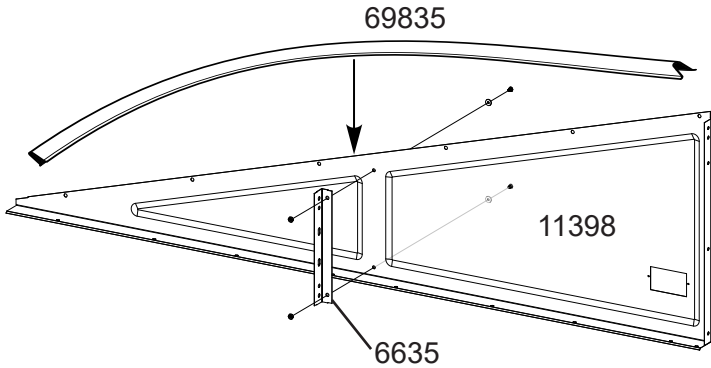
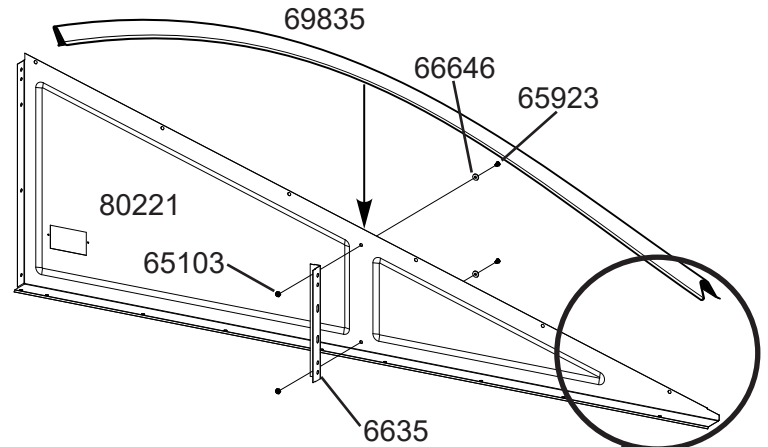
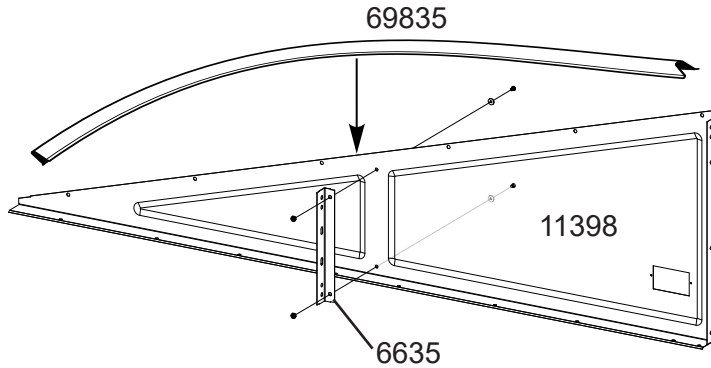
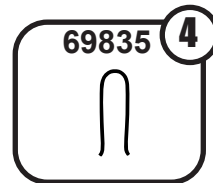
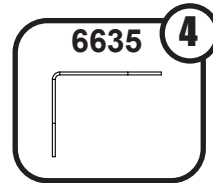
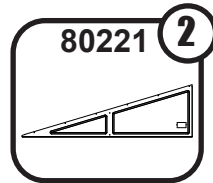
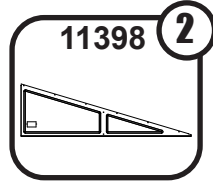
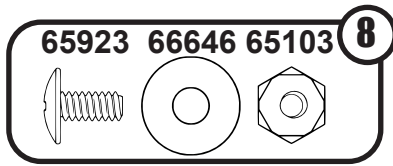

CAUTION:

To avoid mishap on the sharp edge the edge trim must remain in place on the top edge of the gable until right and left roof panels are in place.

PRUDENCE:

Pour éviter les accidents sur l'arête coupante de la garniture de bord, cette garniture doit rester en place sur le bord supérieur du pignon jusqu'à ce que les panneaux de toit droit et gauche soient en place.

ADVERTENCIA:

Para evitar un accidente en el borde filoso, el recuadro del borde debe quedar en su lugar en el borde superior del frontón hasta que los paneles izquierdo y derecho están colocados.

VORSICHT:

Um Unfälle zu vermeiden, sollte die scharfe Kante der Randleiste auf der oberen Kante des Giebels verbleiben, bis die rechten und linken Dachpaneelen angebracht sind.

10: GABLES

PIGNON
GABLETE GIEBEL

EN,FR,SP,GE-33MC

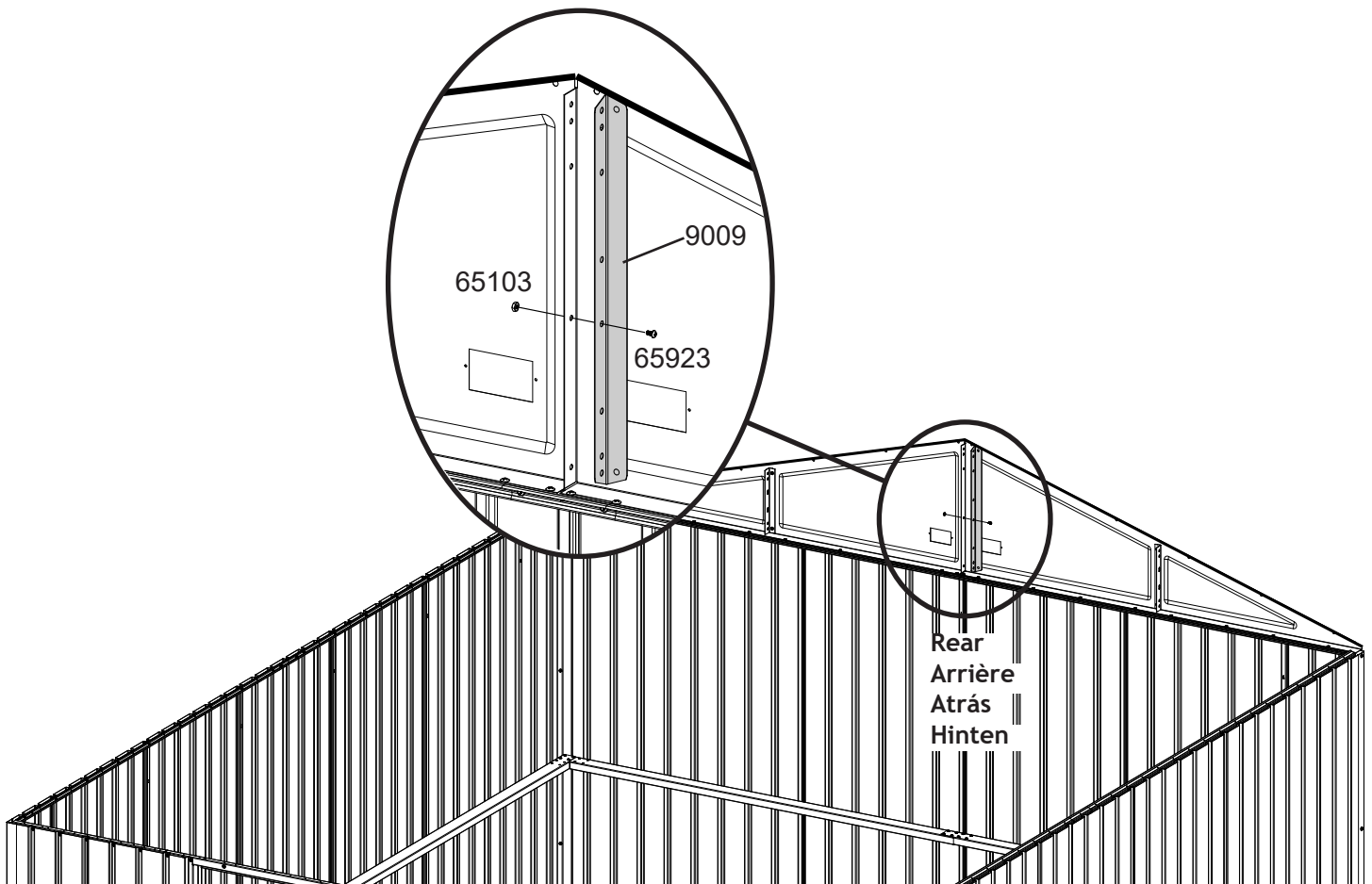
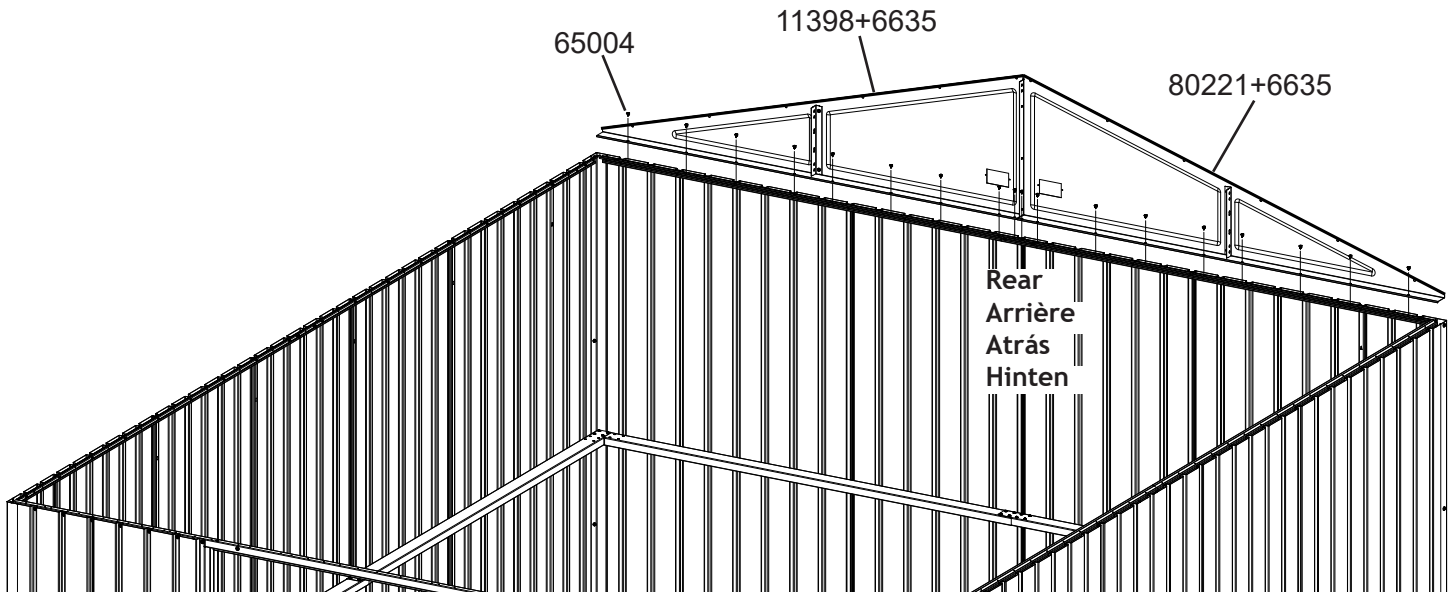
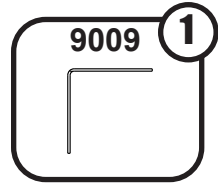
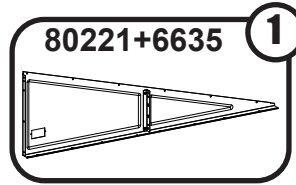
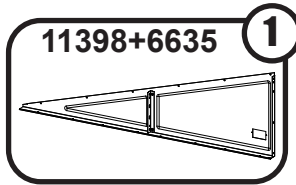
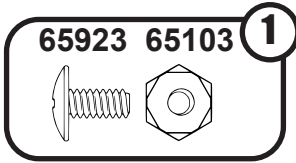
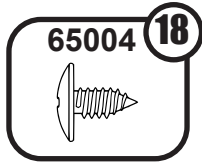

10: GABLES

PIGNON
GABLETE GIEBEL

EN,FR,SP,GE-34MC

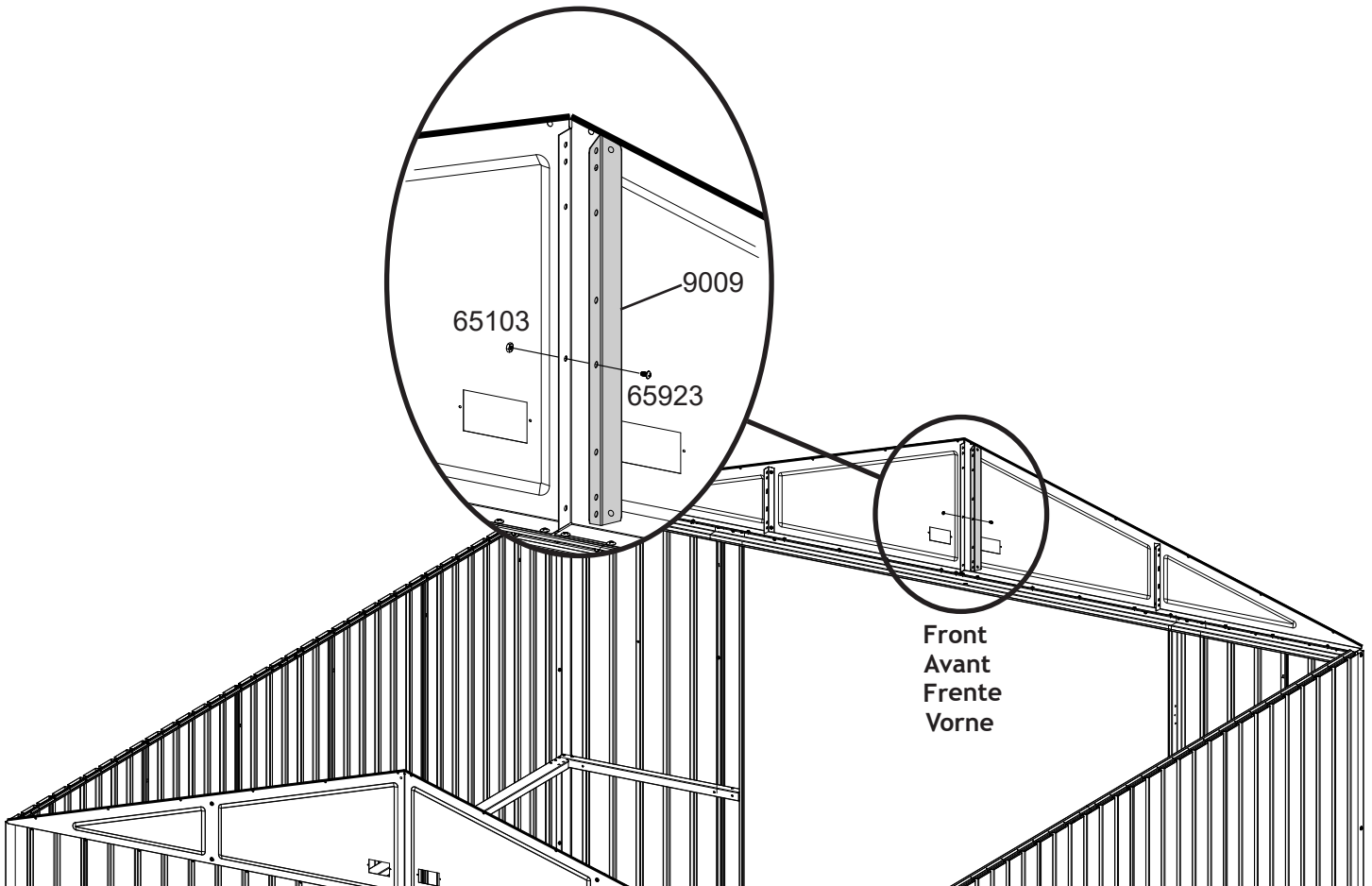
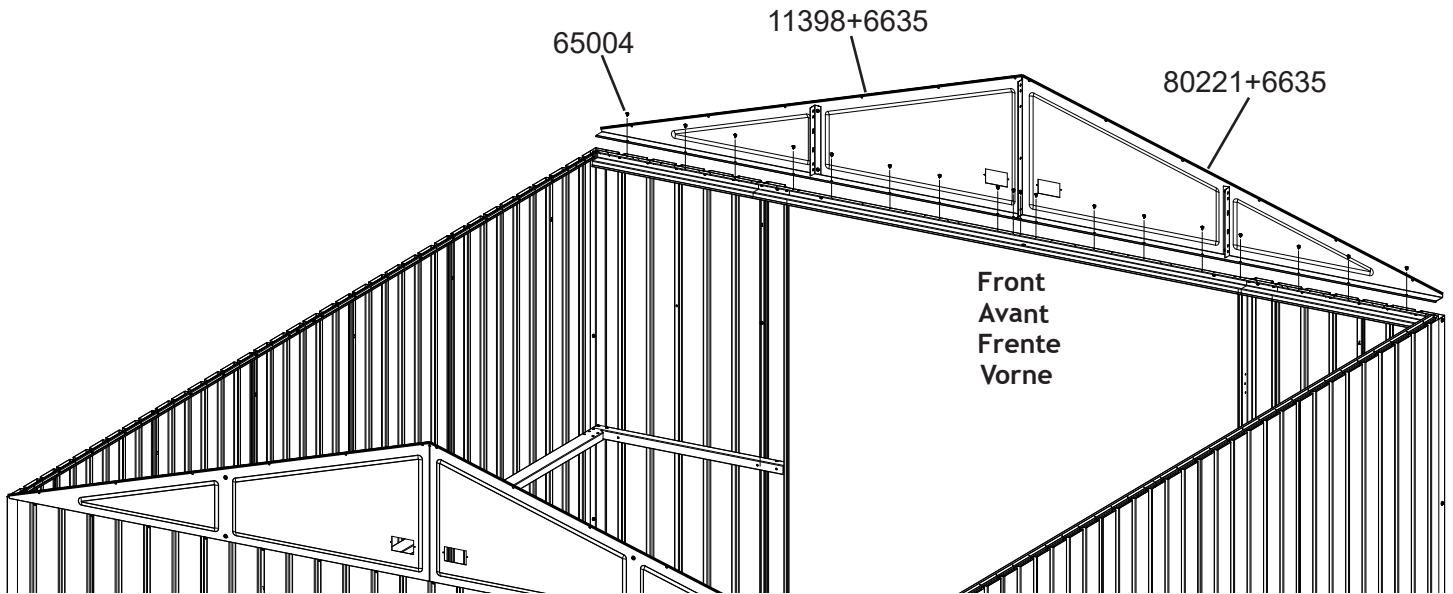
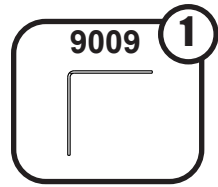
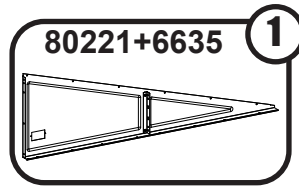
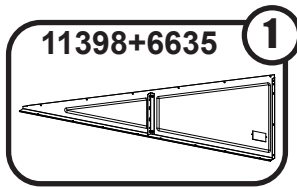
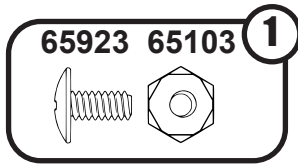
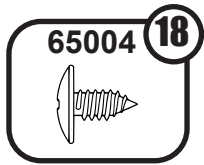

11: ROOF BEAMS

POUTRE DE TOIT
VIGA DEL TECHO DACHTRÄGER

EN,FR,SP,GE-35MC

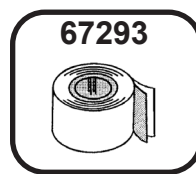
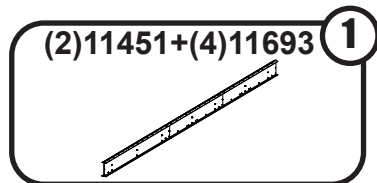
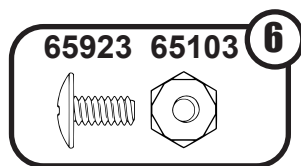

Top View of Gables
Vue de dessus du pignon
Vista superior de gabletes
Draufsicht auf die Giebel

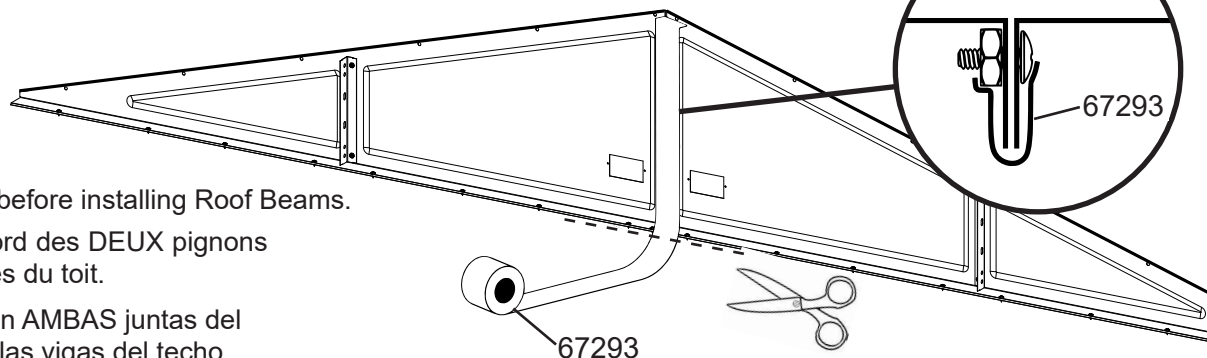

Tape BOTH Gable joints before installing Roof Beams.

Couvrir de ruban le raccord des DEUX pignons avant de poser les poutres du toit.

Coloque cinta adhesiva en AMBAS juntas del gablete antes de instalar las vigas del techo.

Kleben Sie BEIDE Giebelverbindungen zusammen, bevor Sie die Dachbalken montieren.

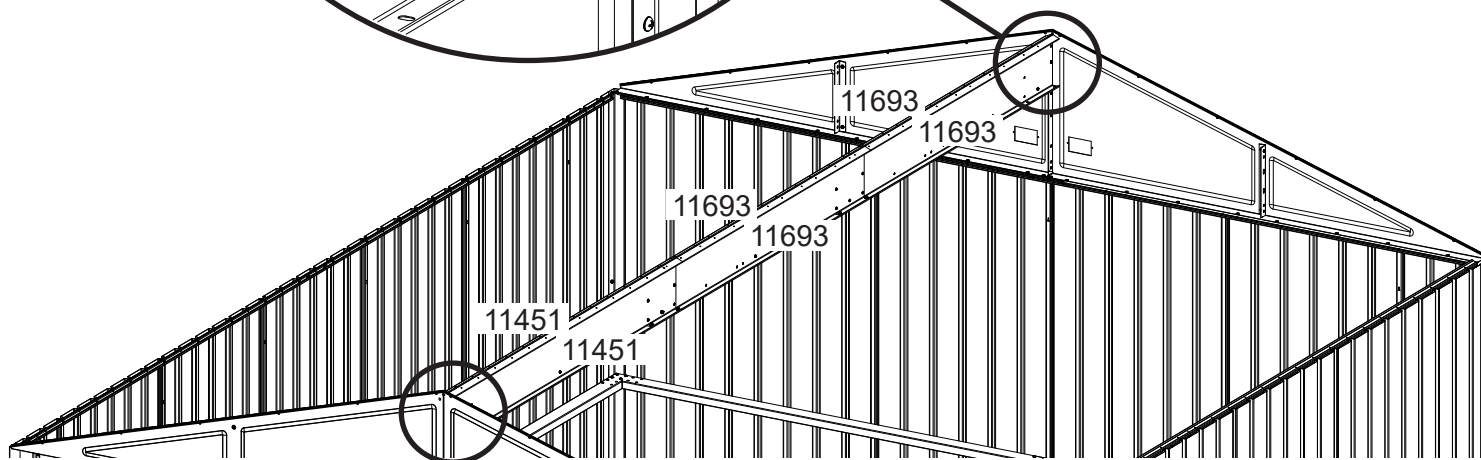
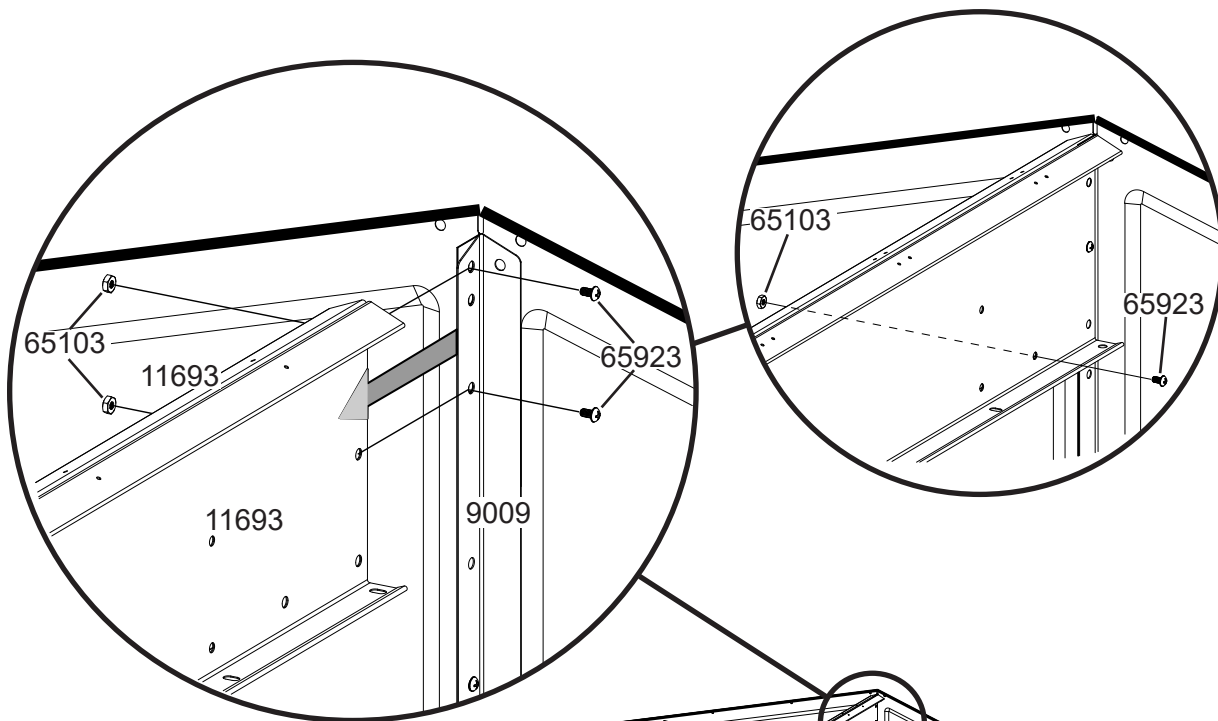

11: ROOF BEAMS

POUTRE DE TOIT
VIGA DEL TECHO DACHTRÄGER

EN,FR,SP,GE-36MC

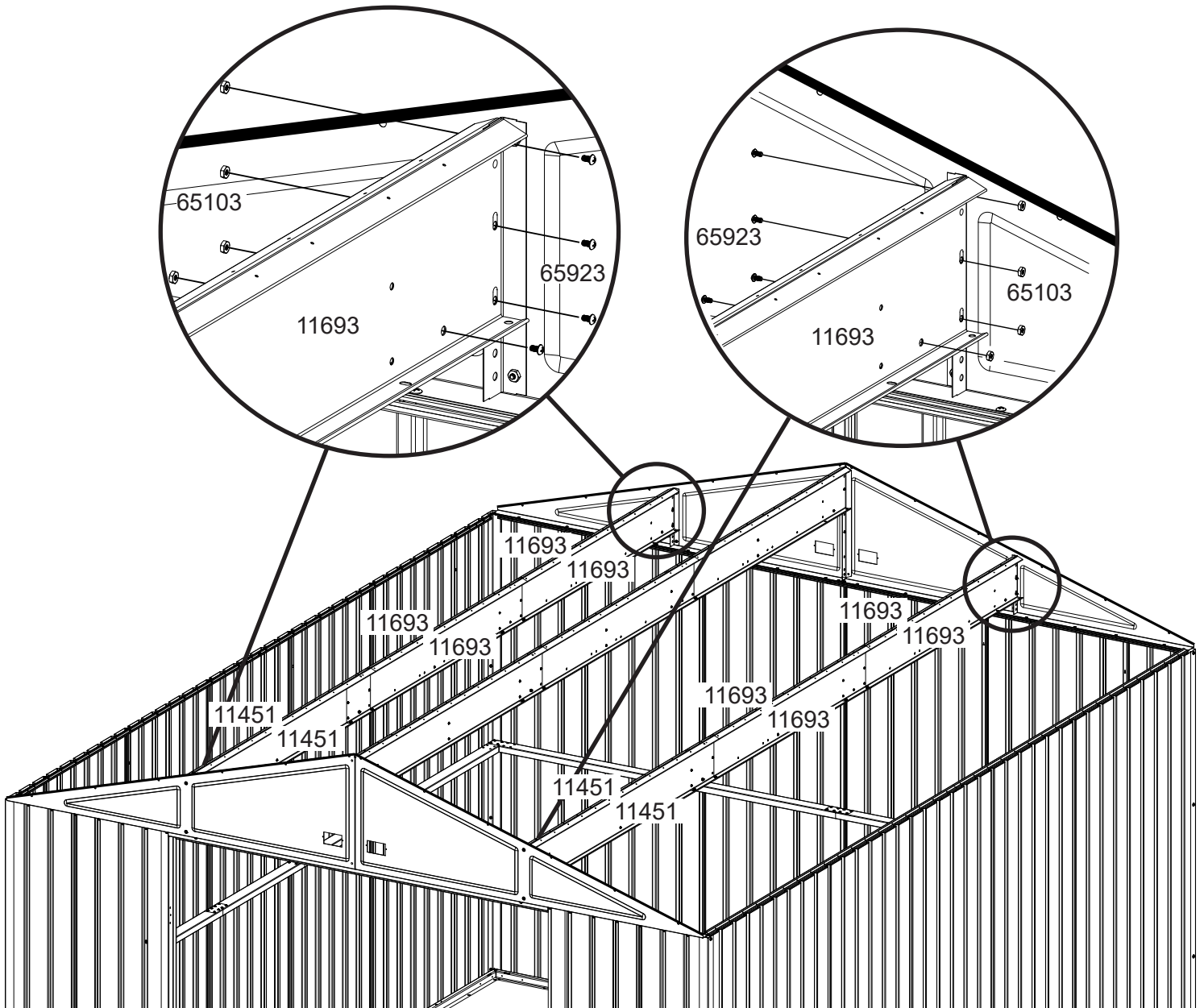
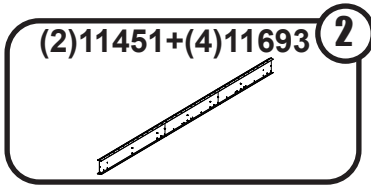
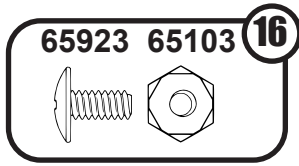

12: ROOF BEAM BRACE

CONTREFICHE DE POUTRE DE TOIT
ABRAZADERA DE LA VIGA DEL TECHO

EN,FR,SP,GE-37MC

DACHTRÄGER VERSTÄRKUNG

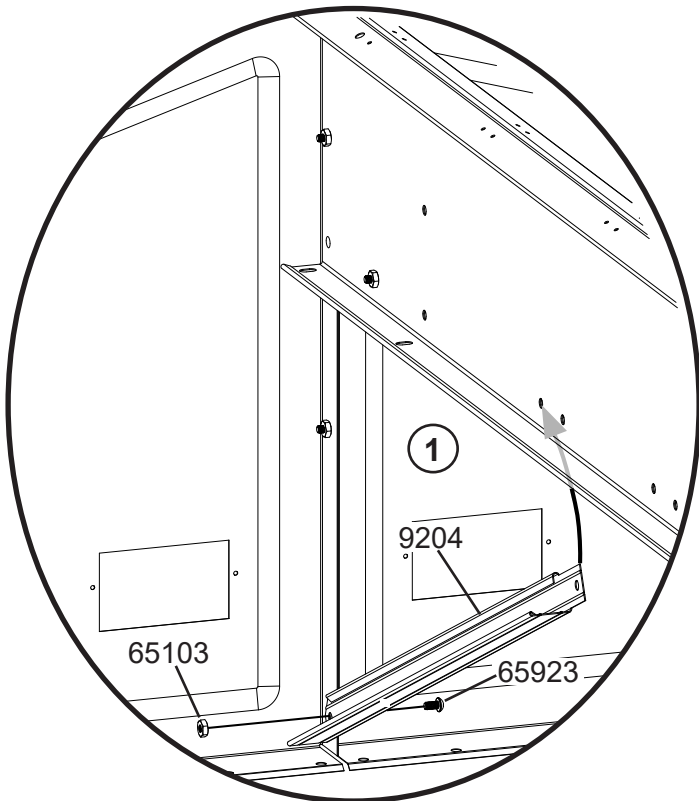
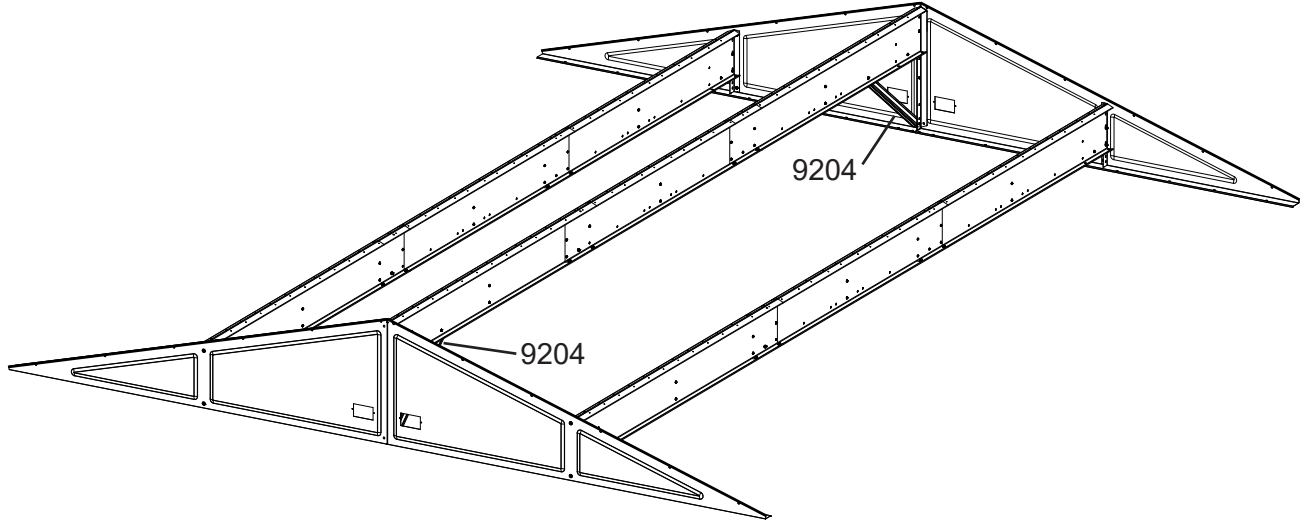
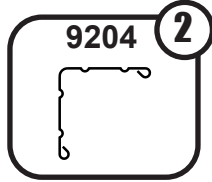
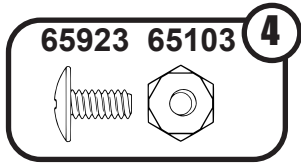

X2

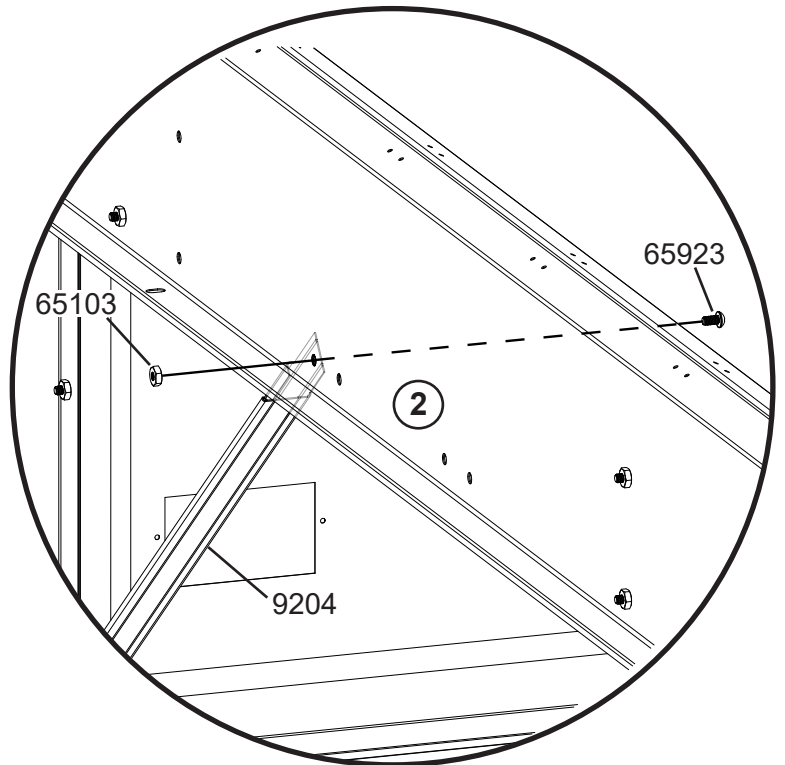

X2

13: ROOF PANELS

PANNEAU DE TOIT
 PANEL DEL TECHO DACHBLECH

EN,FR,SP,GE-38MC

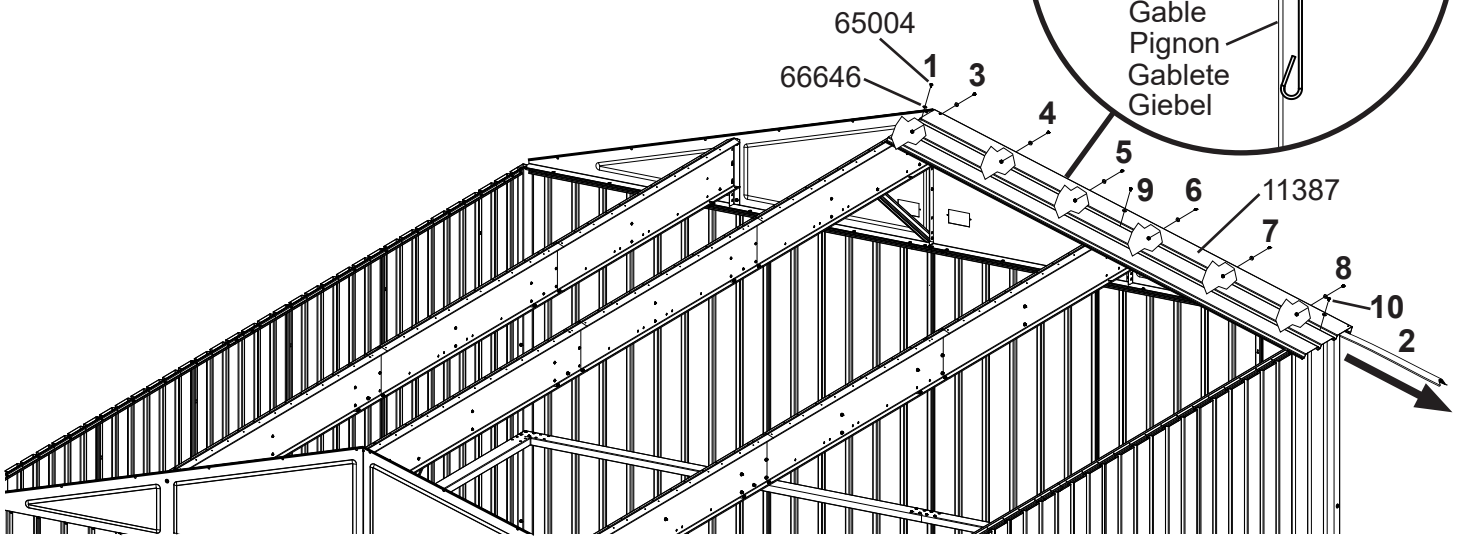
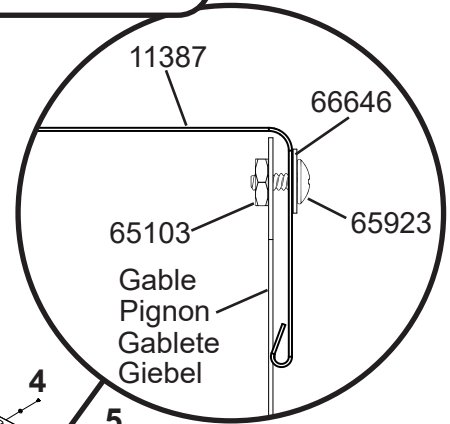
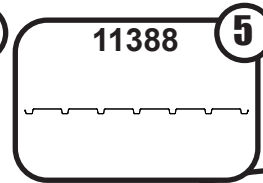
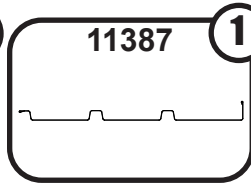
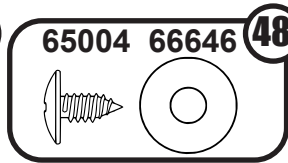
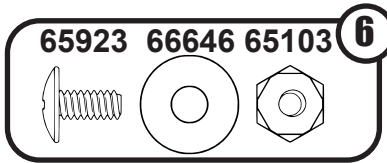

Front Frente
 Avant Vorne

ALWAYS COVER THE ARROW
 TOUJOURS COUVRIR LA FLÈCHE
 DEBE CUBRIRSE SIEMPRE LA FLECHA
 IMMER DEN PFEIL ABDECKEN

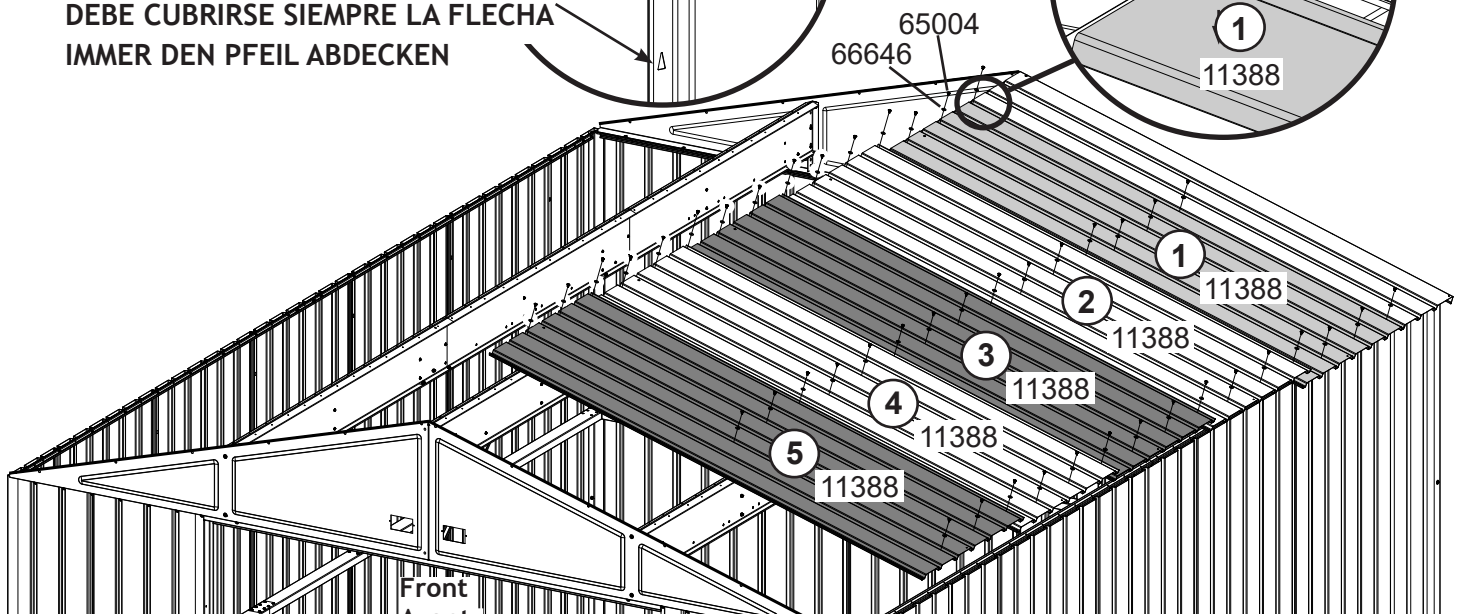
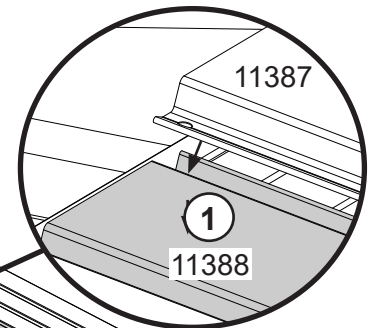
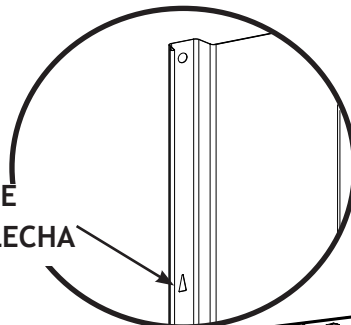

Front
 Avant
 Frente
 Vorne

13: ROOF PANELS

PANNEAU DE TOIT
 PANEL DEL TECHO DACHBLECH

EN,FR,SP,GE-39MC

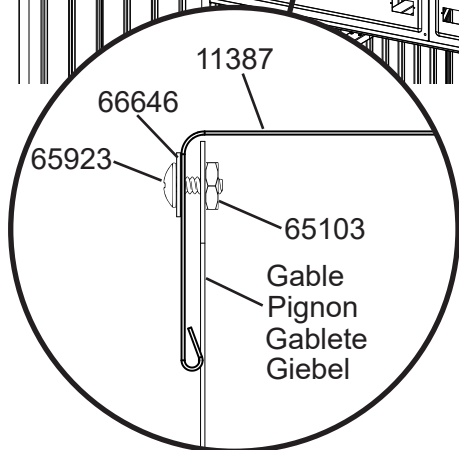
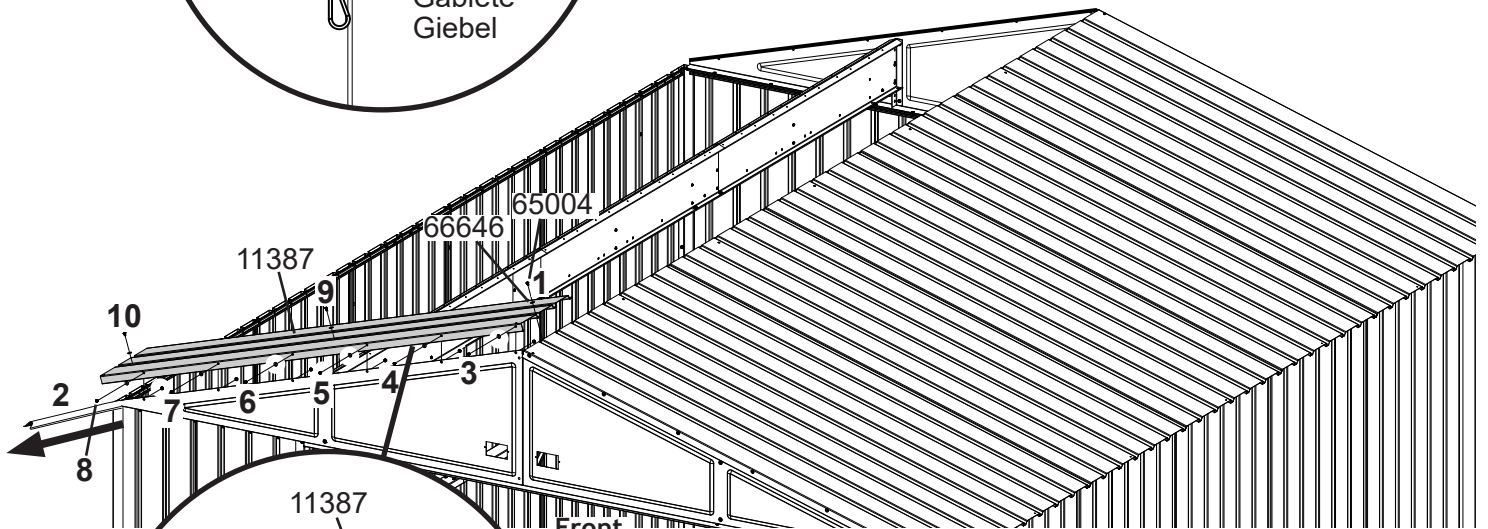
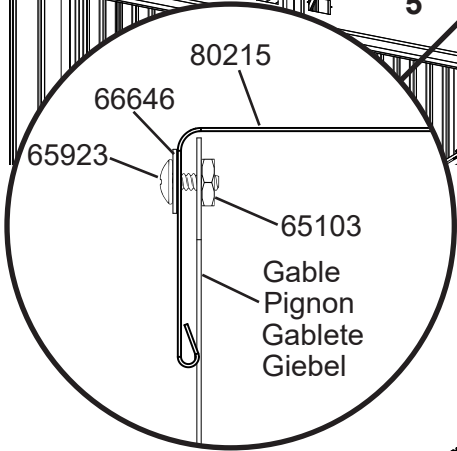
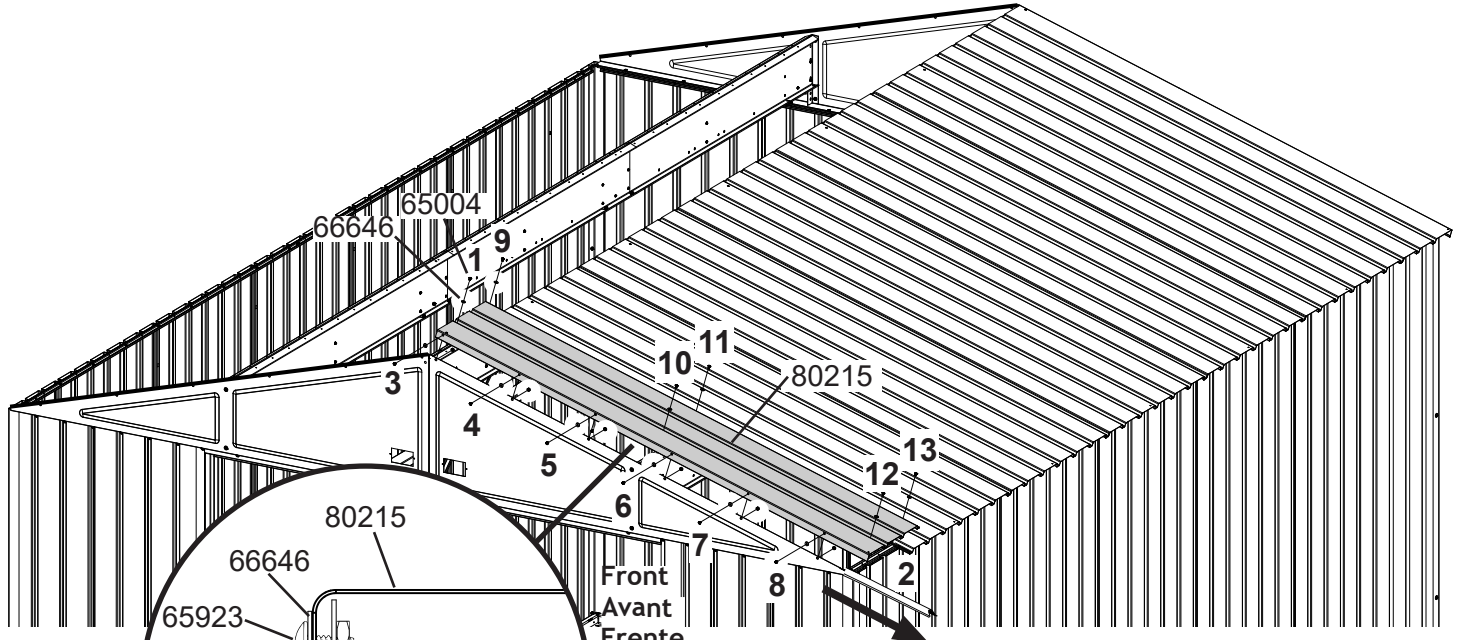
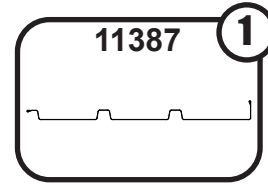
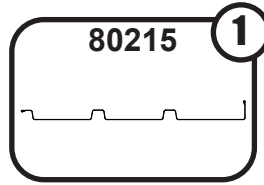
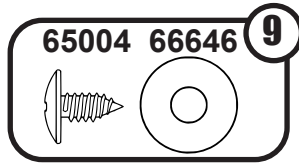
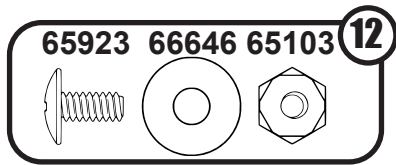

13: ROOF PANELS

PANNEAU DE TOIT
 PANEL DEL TECHO DACHBLECH

EN,FR,SP,GE-40MC

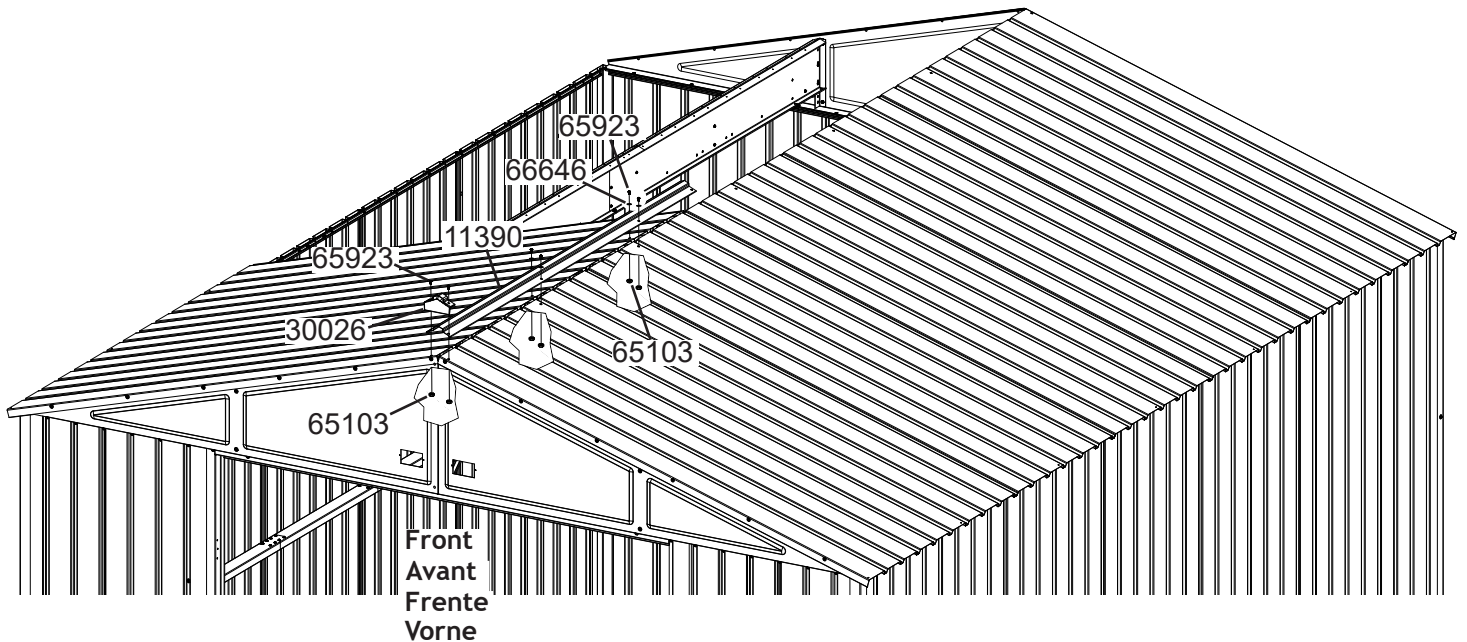
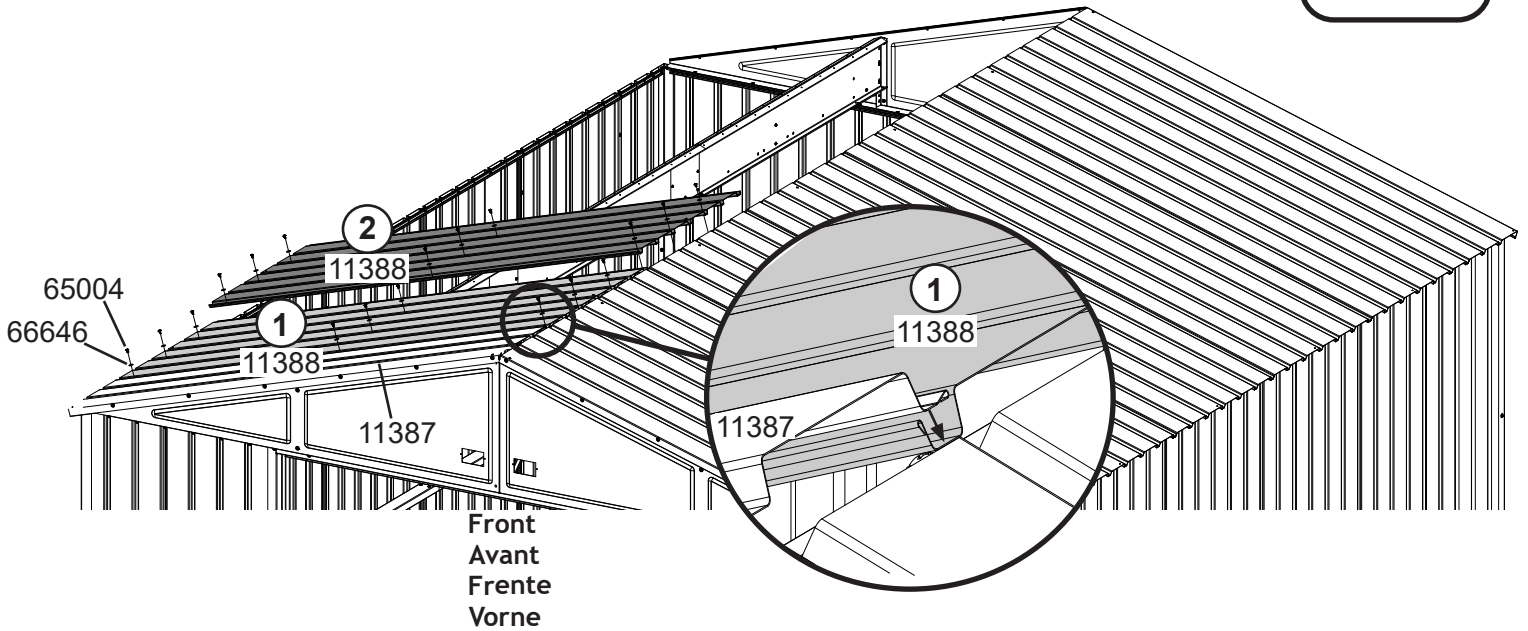
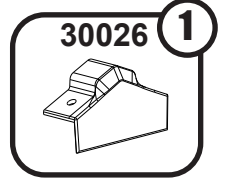
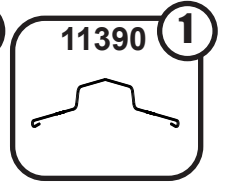
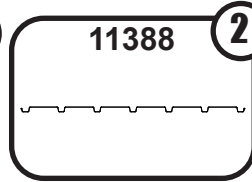
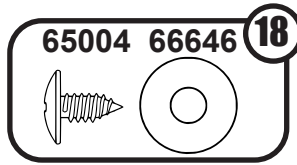
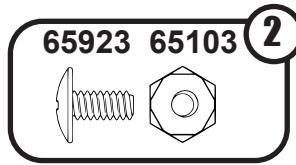
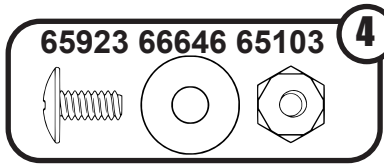

13: ROOF PANELS

PANNEAU DE TOIT
PANEL DEL TECHO DACHBLECH

EN,FR,SP,GE-41MC

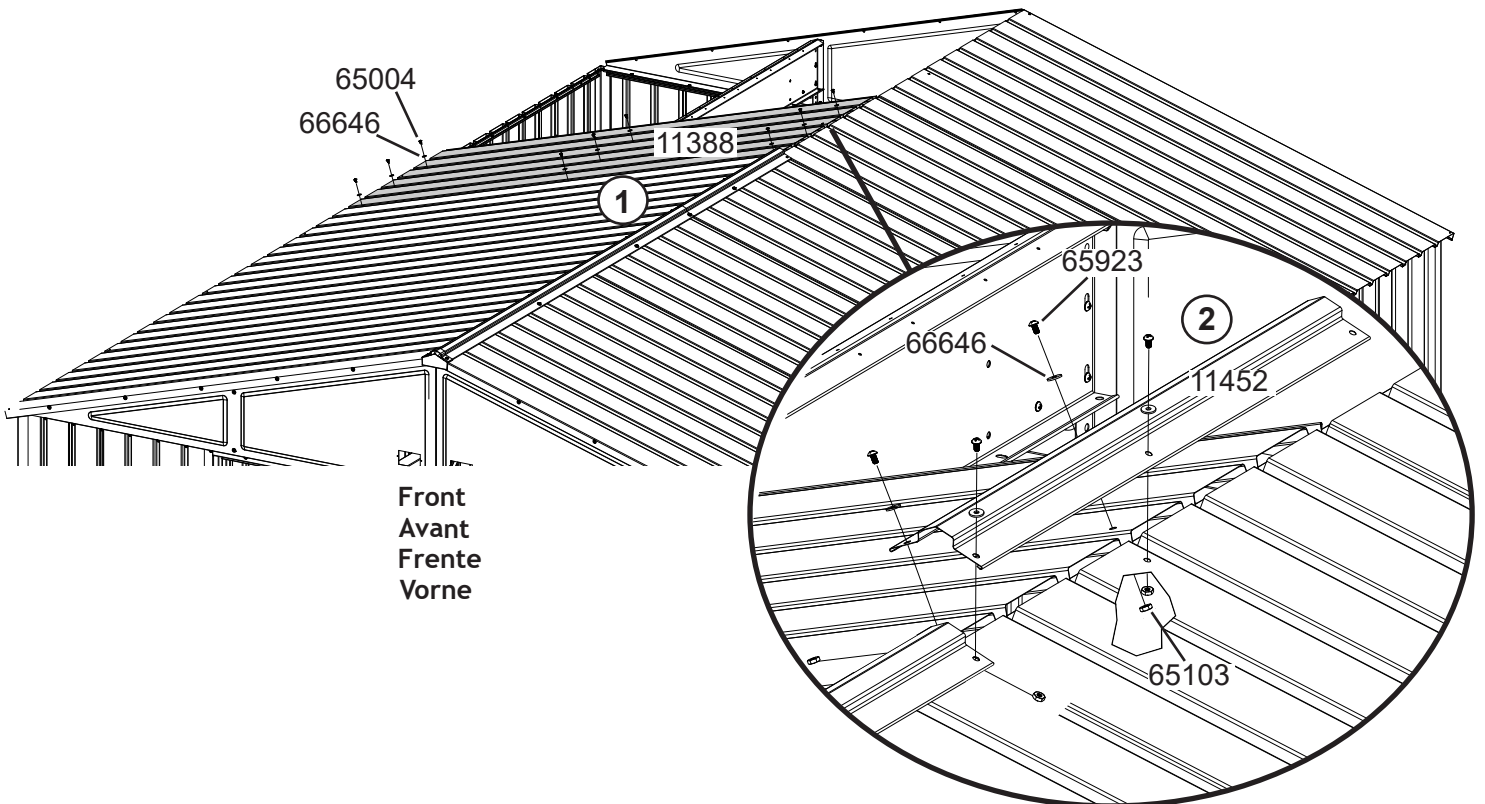
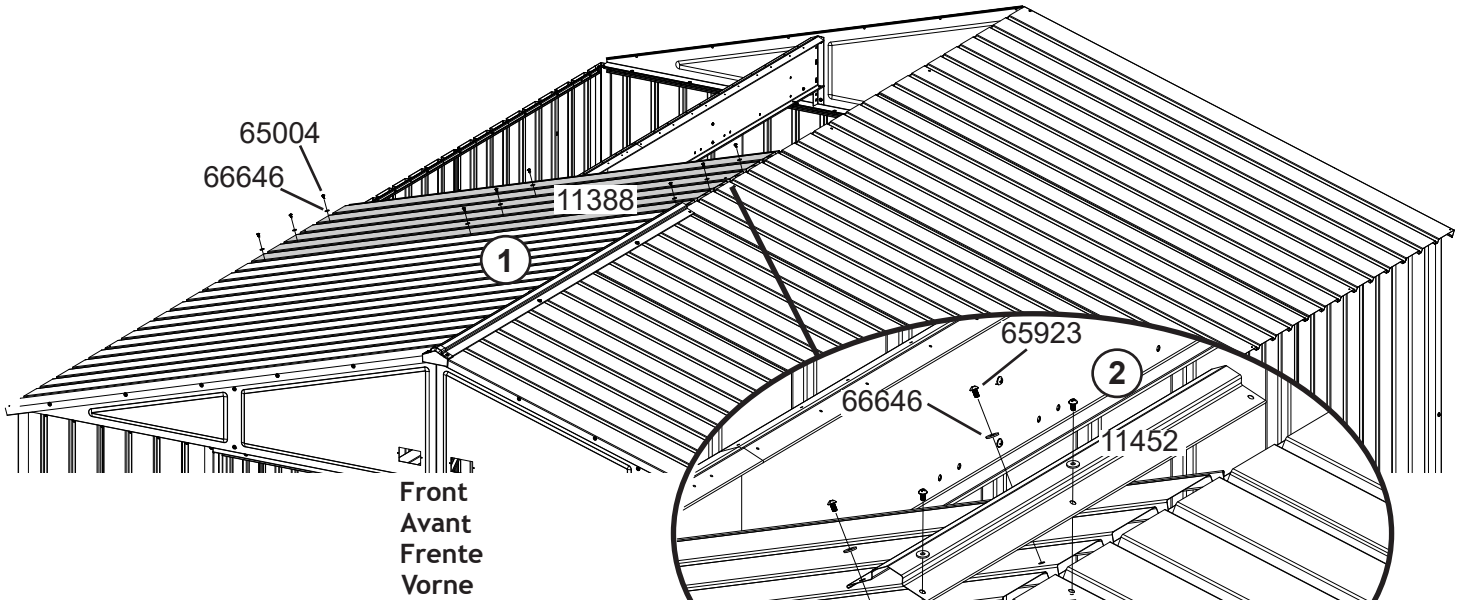
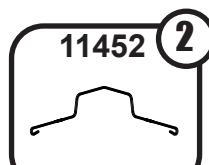
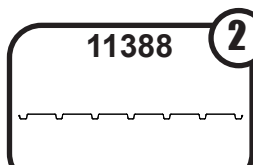
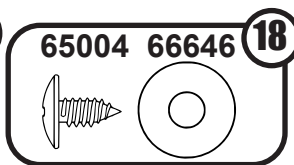
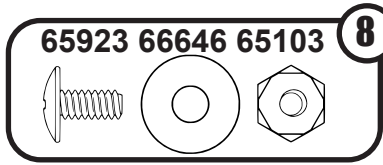

13: ROOF PANELS

PANNEAU DE TOIT
PANEL DEL TECHO DACHBLECH

EN,FR,SP,GE-42MC

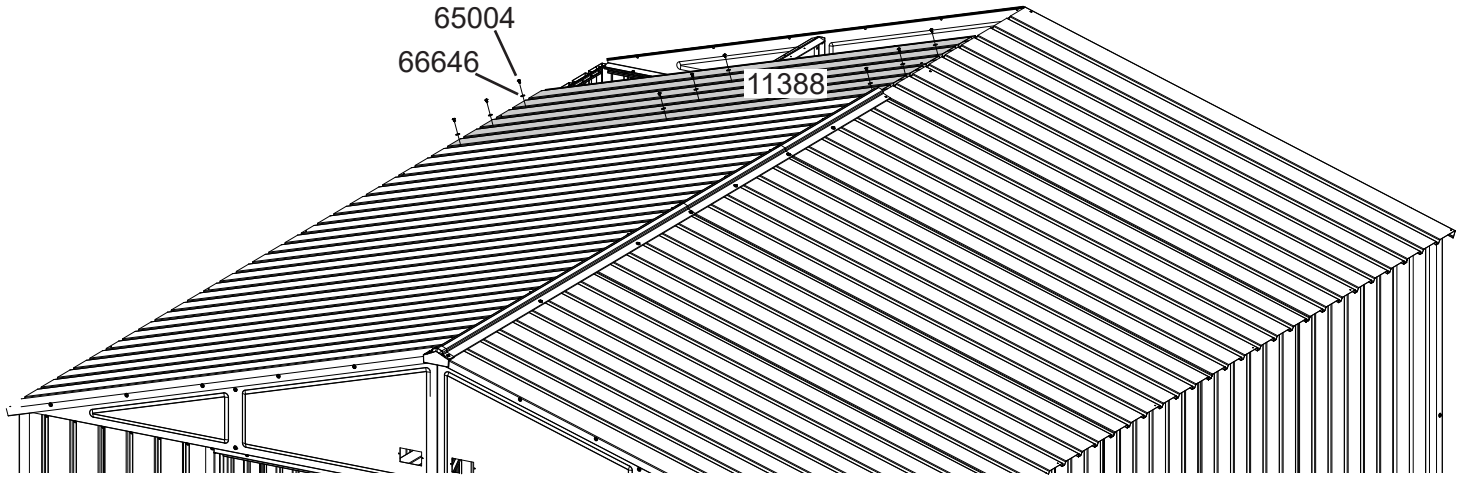
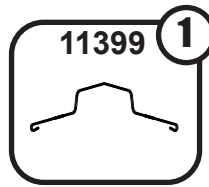
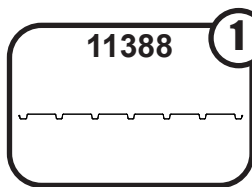
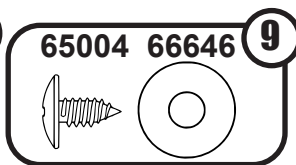
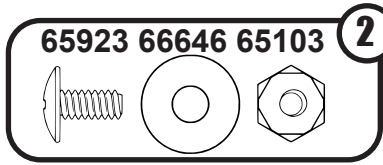

Front
Avant
Frente
Vorne

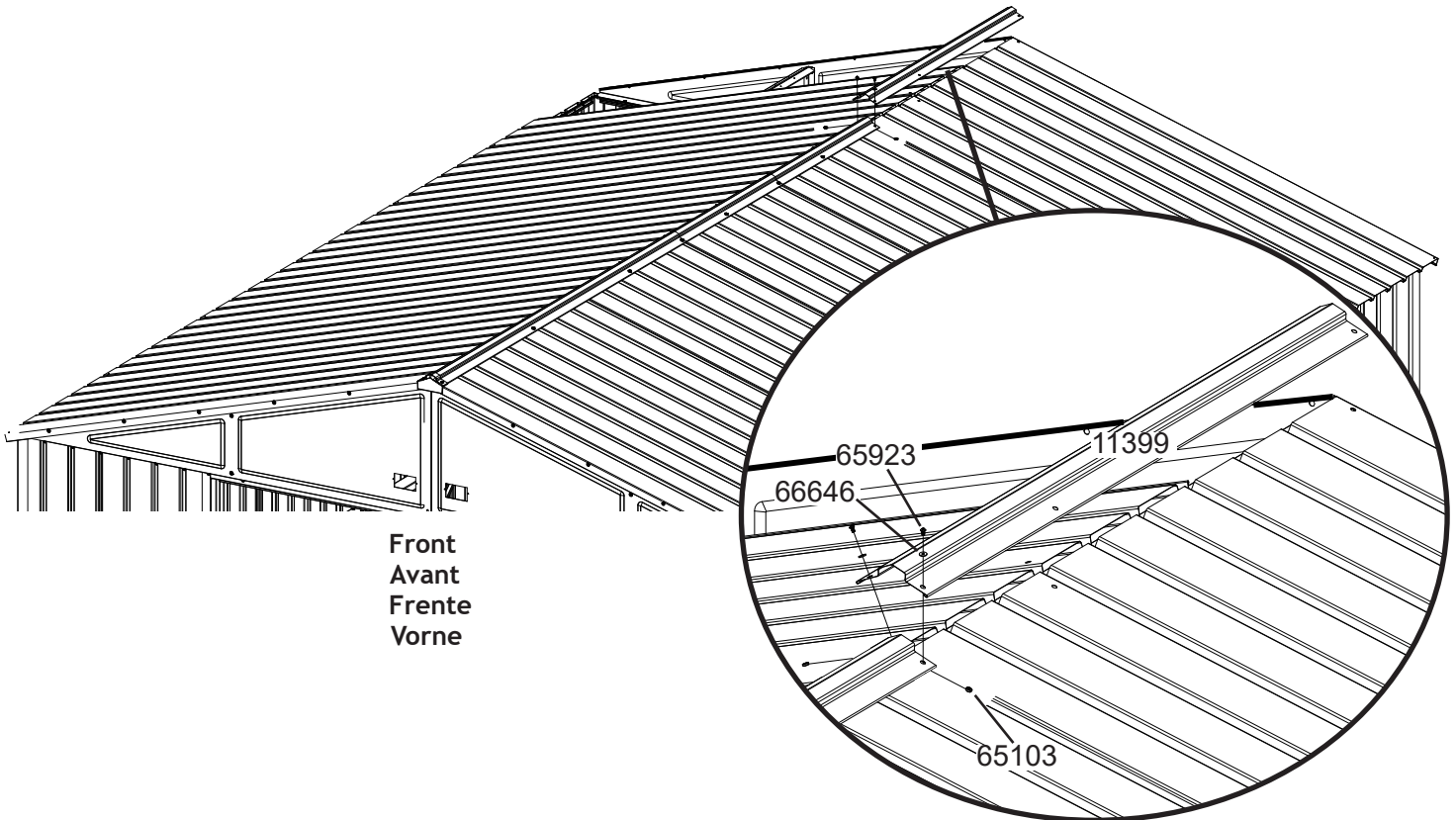

Front
Avant
Frente
Vorne

13: ROOF PANELS

PANNEAU DE TOIT
 PANEL DEL TECHO DACHBLECH

EN,FR,SP,GE-43MC

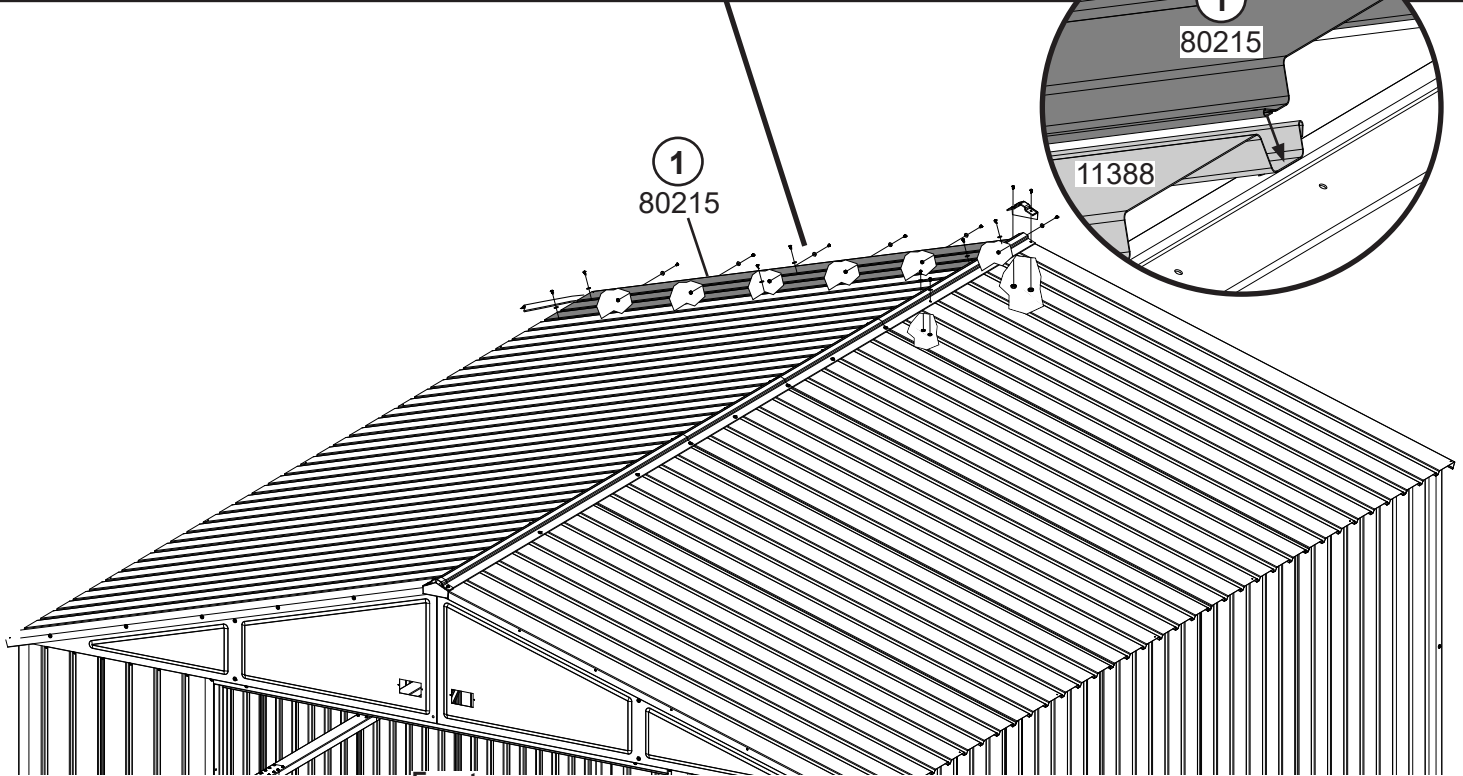
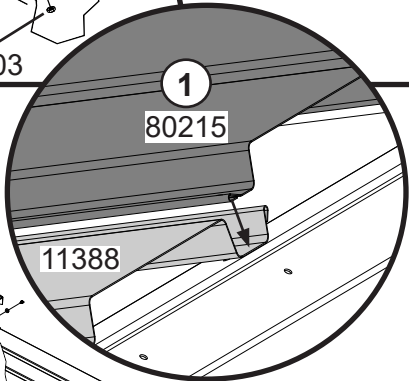
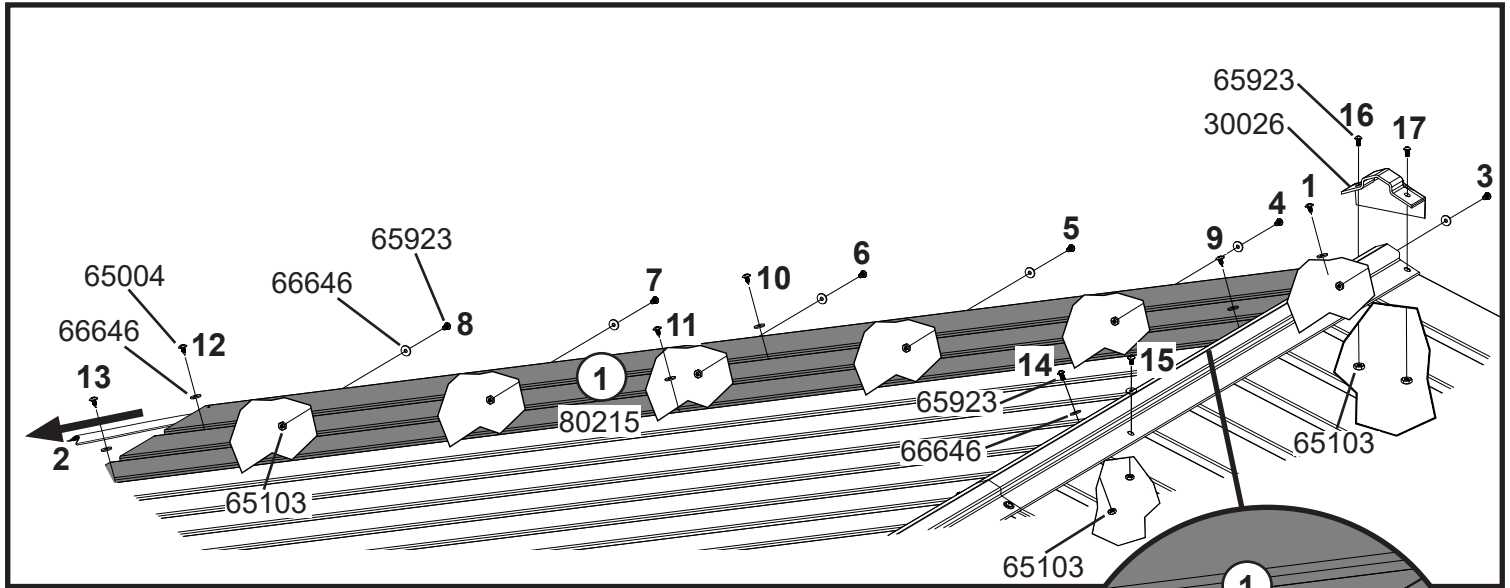
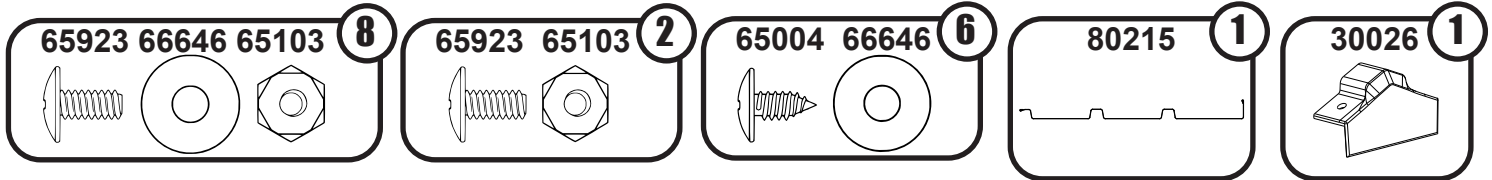

Front
 Avant
 Frente
 Vorne

14: ROOF TRIM

GARNITURE DE TOIT
CONTRAMARCO DEL TECHO DACHABSCHLUSSLEISTE

EN,FR,SP,GE-44MC

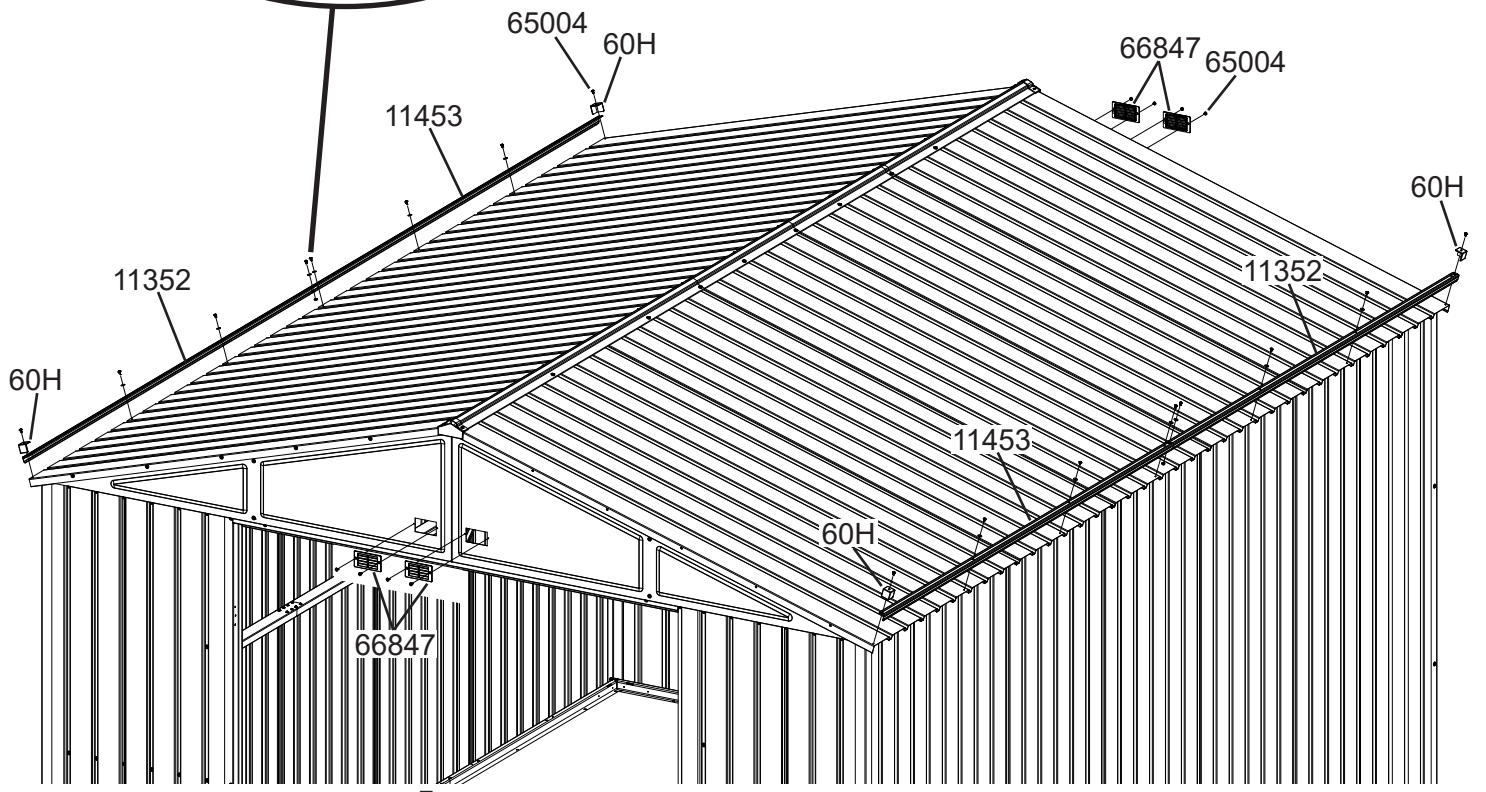
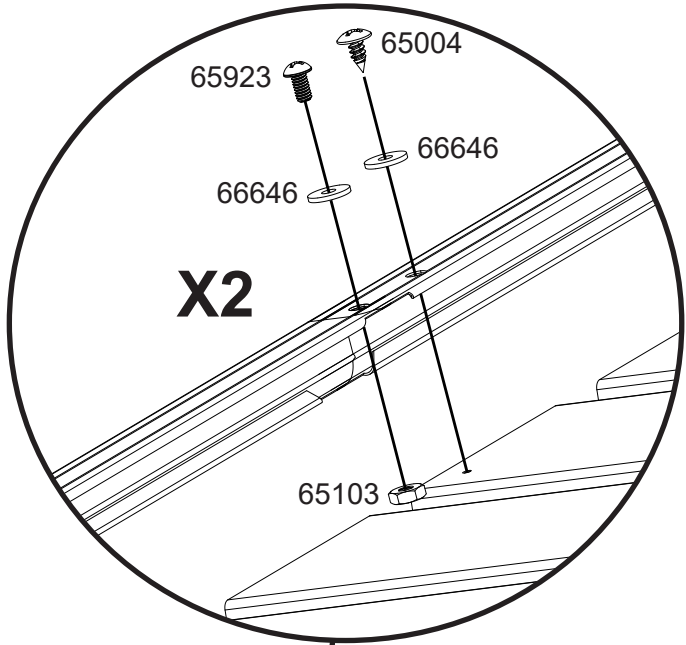
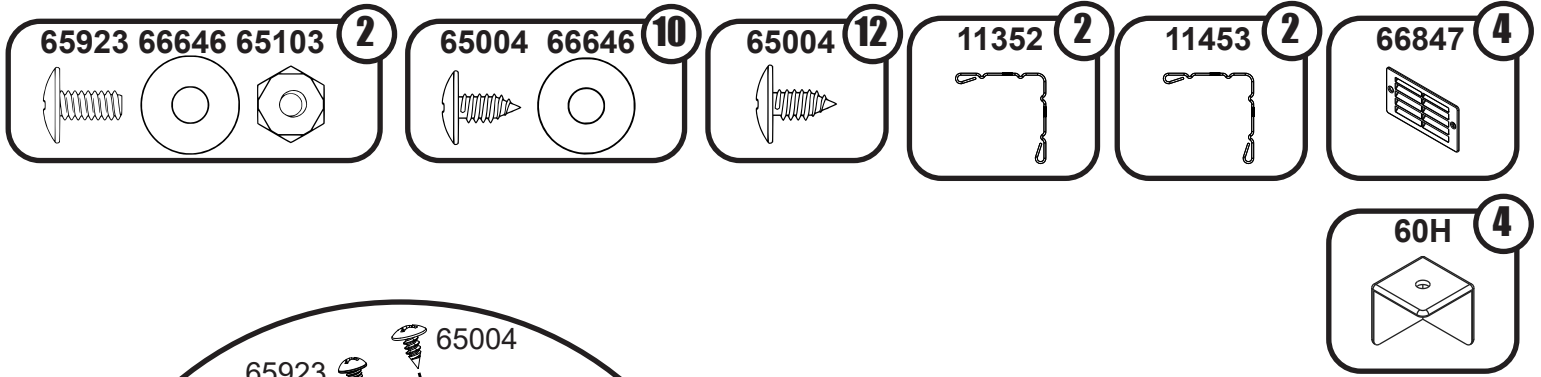

Front
Avant
Frente
Vorne

15: DOOR ASSEMBLY *PORTE ASSEMBLÉE* *ENSAMBLAJE DE LA PUERTA MONTAGE DER TÜRE*

43HU

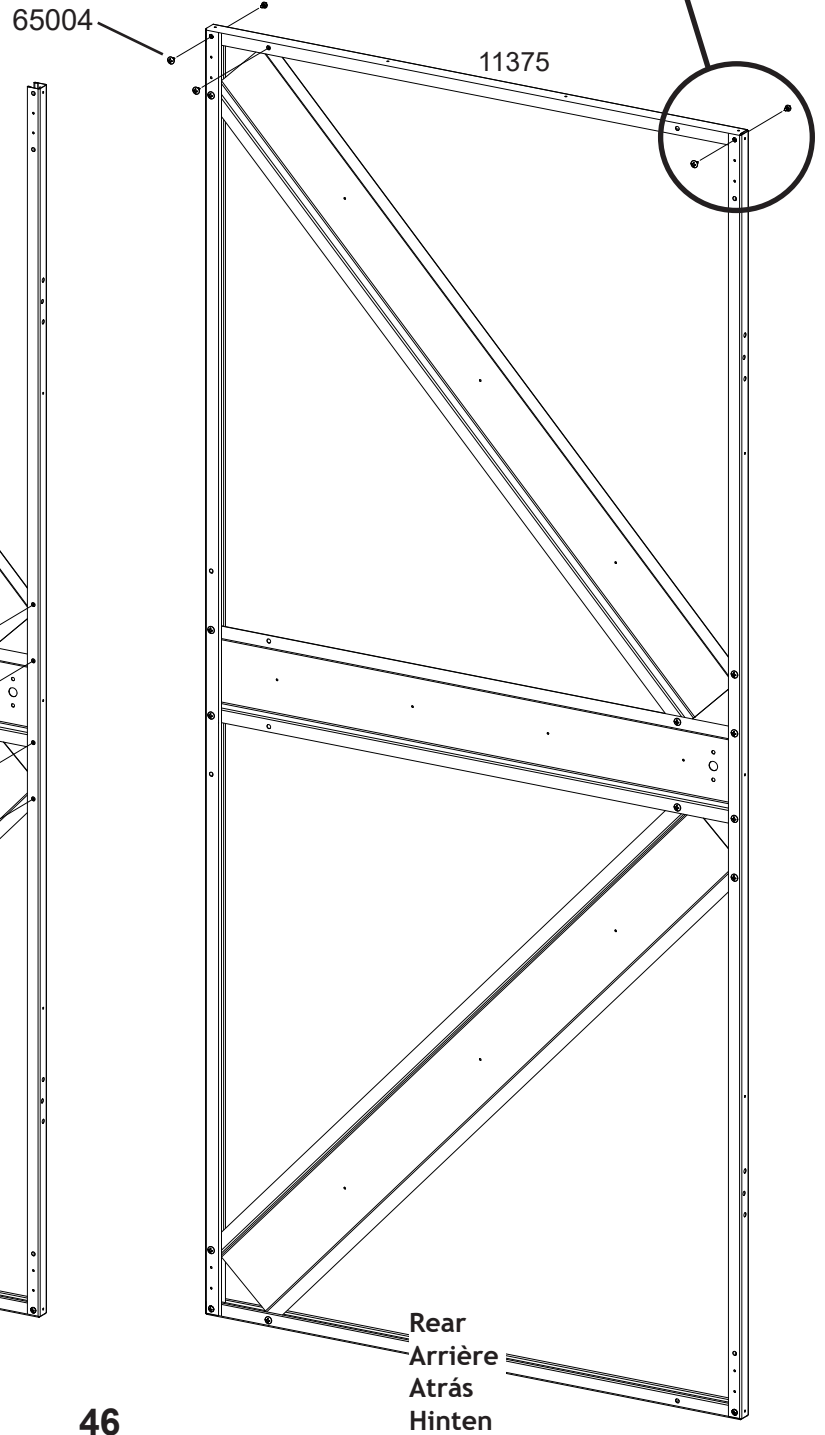
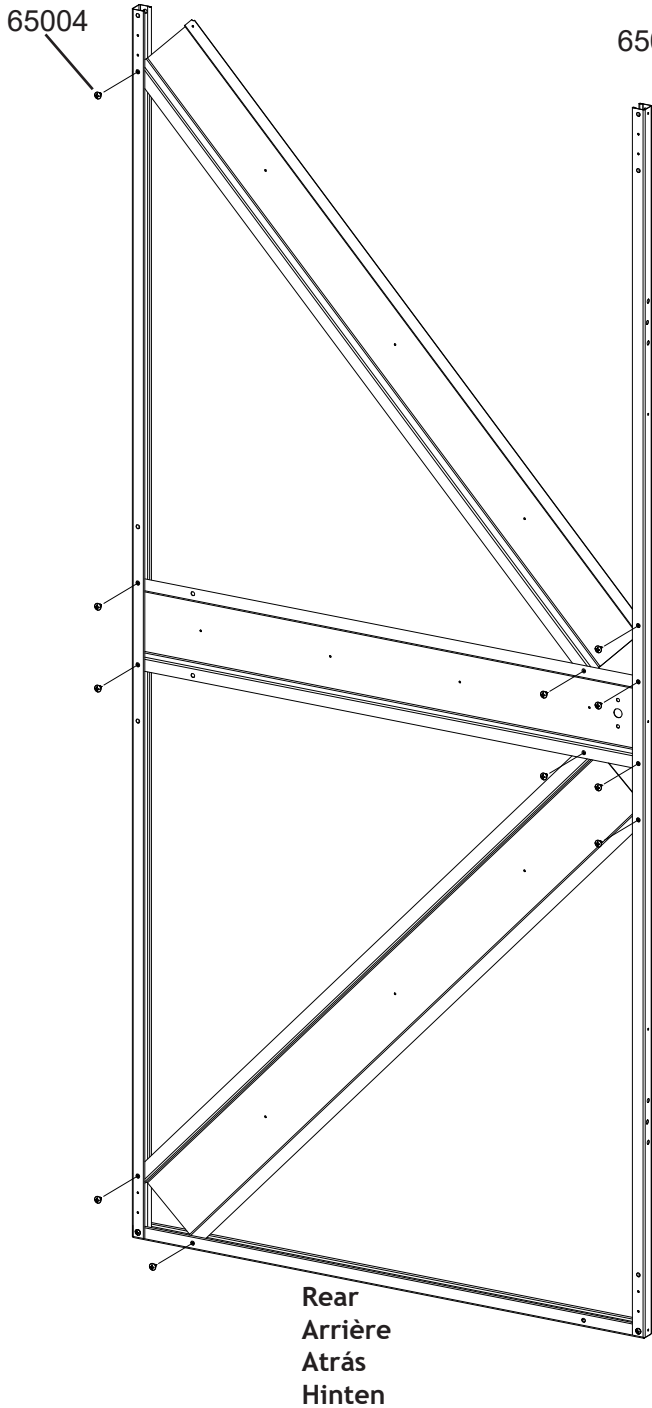
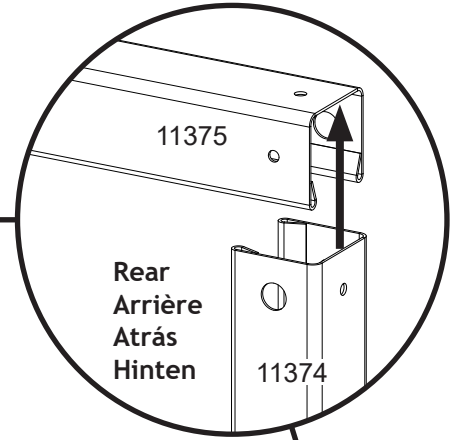
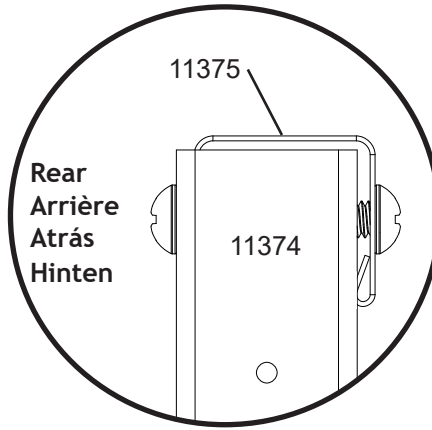
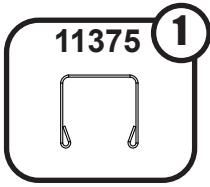
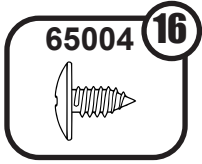

15: DOOR ASSEMBLY *PORTE ASSEMBLÉE* *ENSAMBLAJE DE LA PUERTA MONTAGE DER TÜRE*

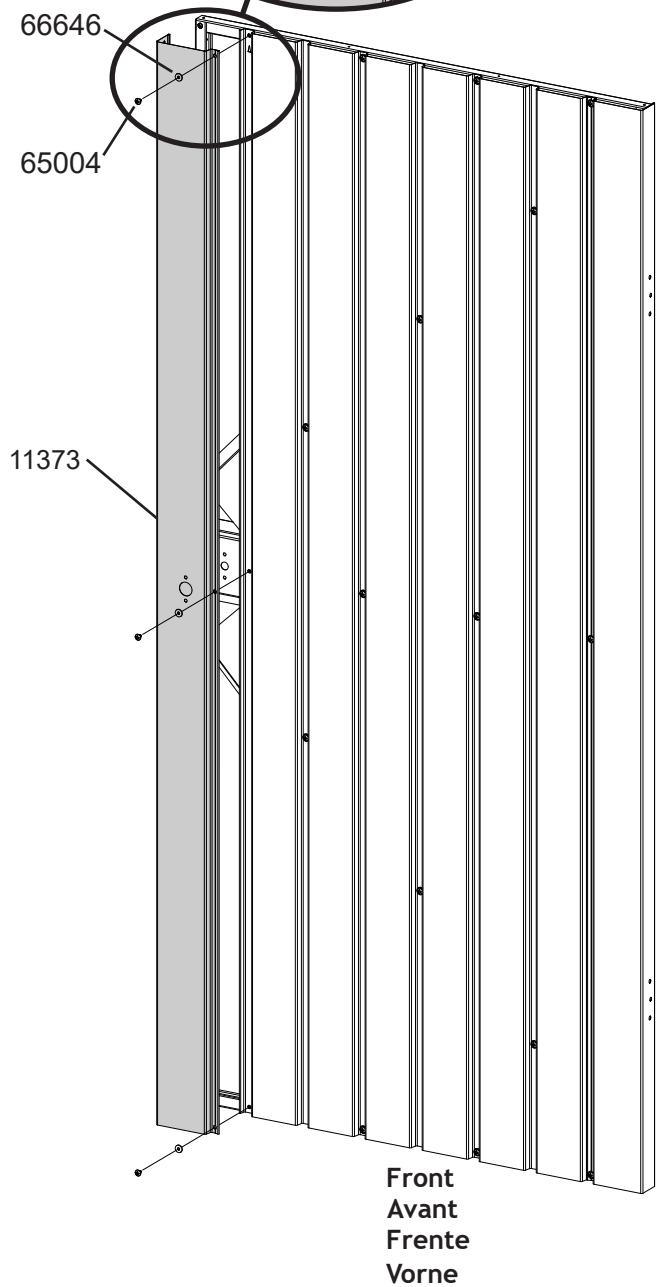
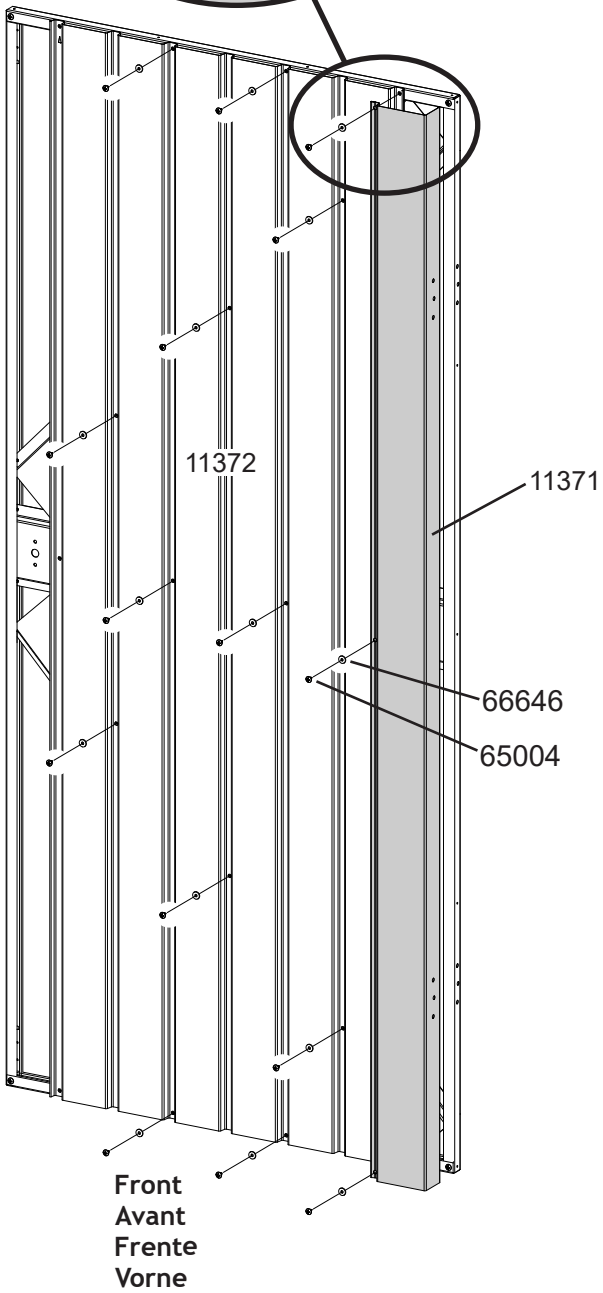
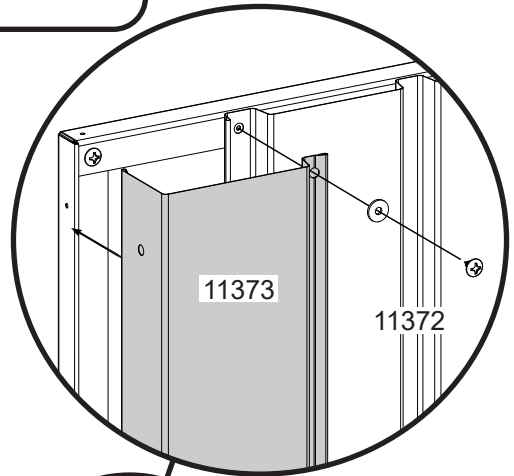
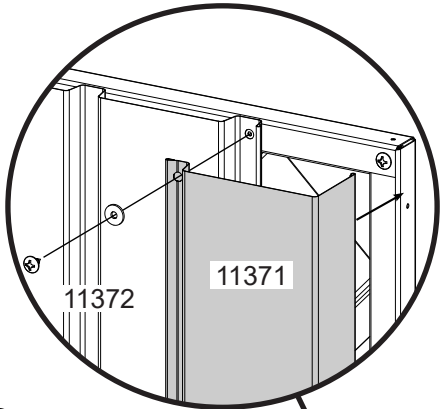
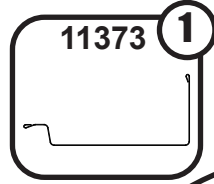
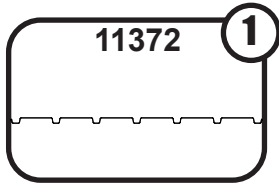
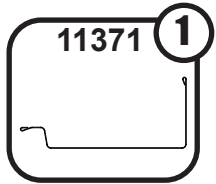
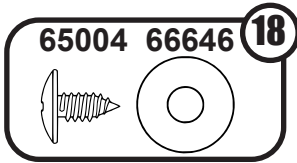

15: DOOR ASSEMBLY *PORTE ASSEMBLÉE* *ENSAMBLAJE DE LA PUERTA MONTAGE DER TÜRE*

45HUb

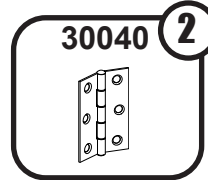
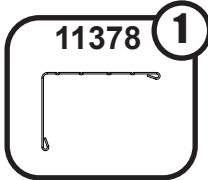
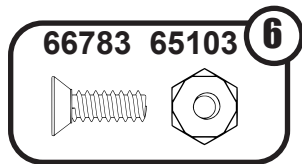
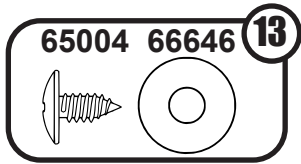

Right Door Assembly
Ensemble de porte droite
Ensamblaje de la puerta derecha
Montage der rechten Tür

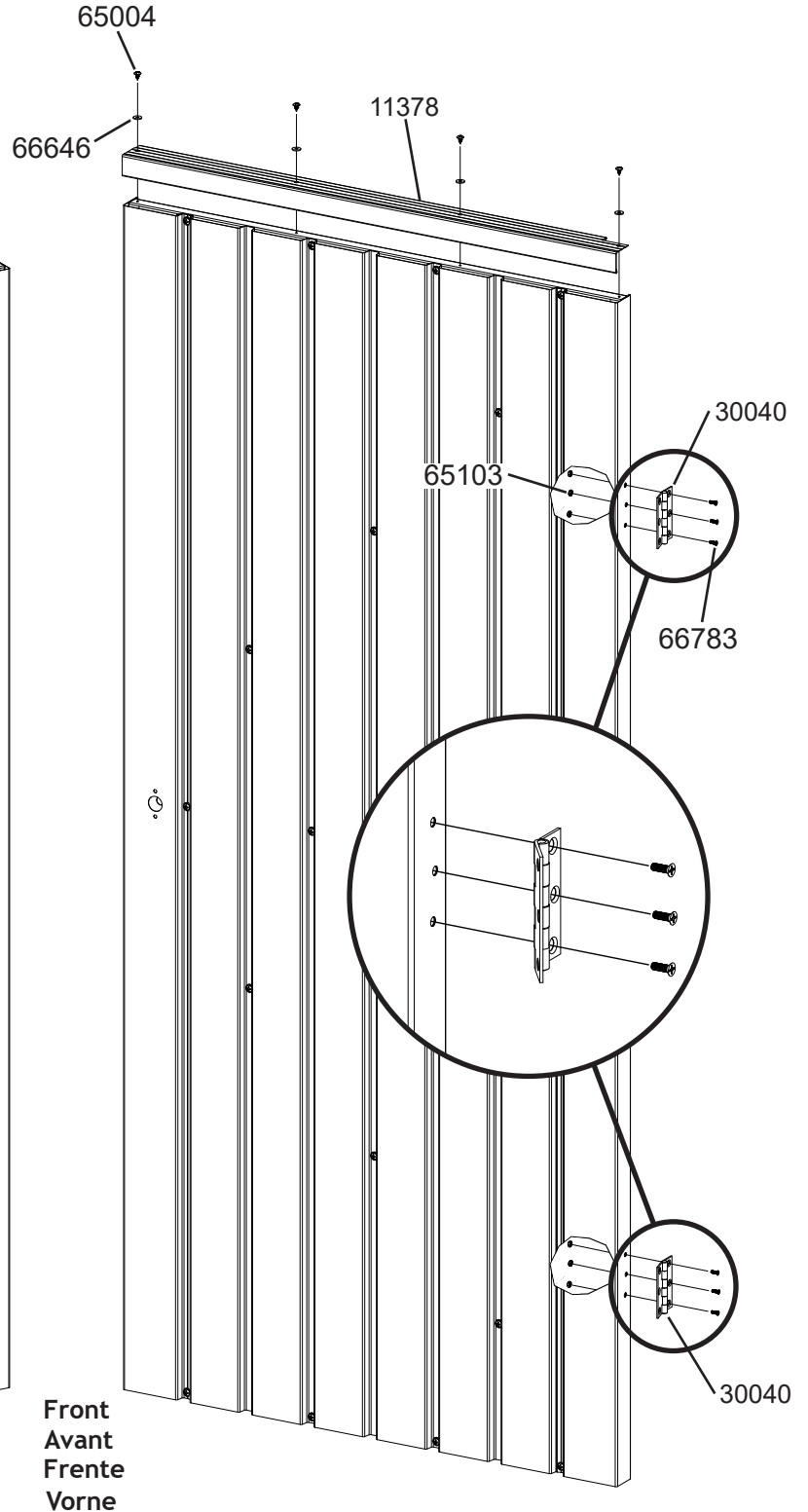
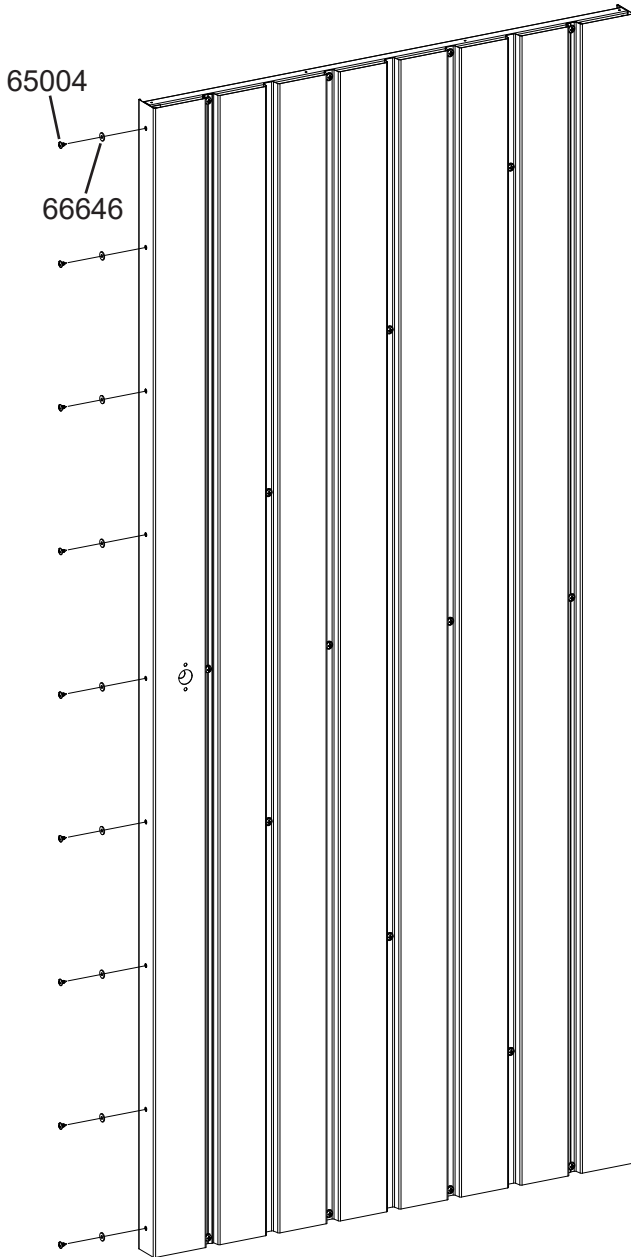

15: DOOR ASSEMBLY *PORTE ASSEMBLÉE* *ENSAMBLAJE DE LA PUERTA MONTAGE DER TÜRE*

47HU

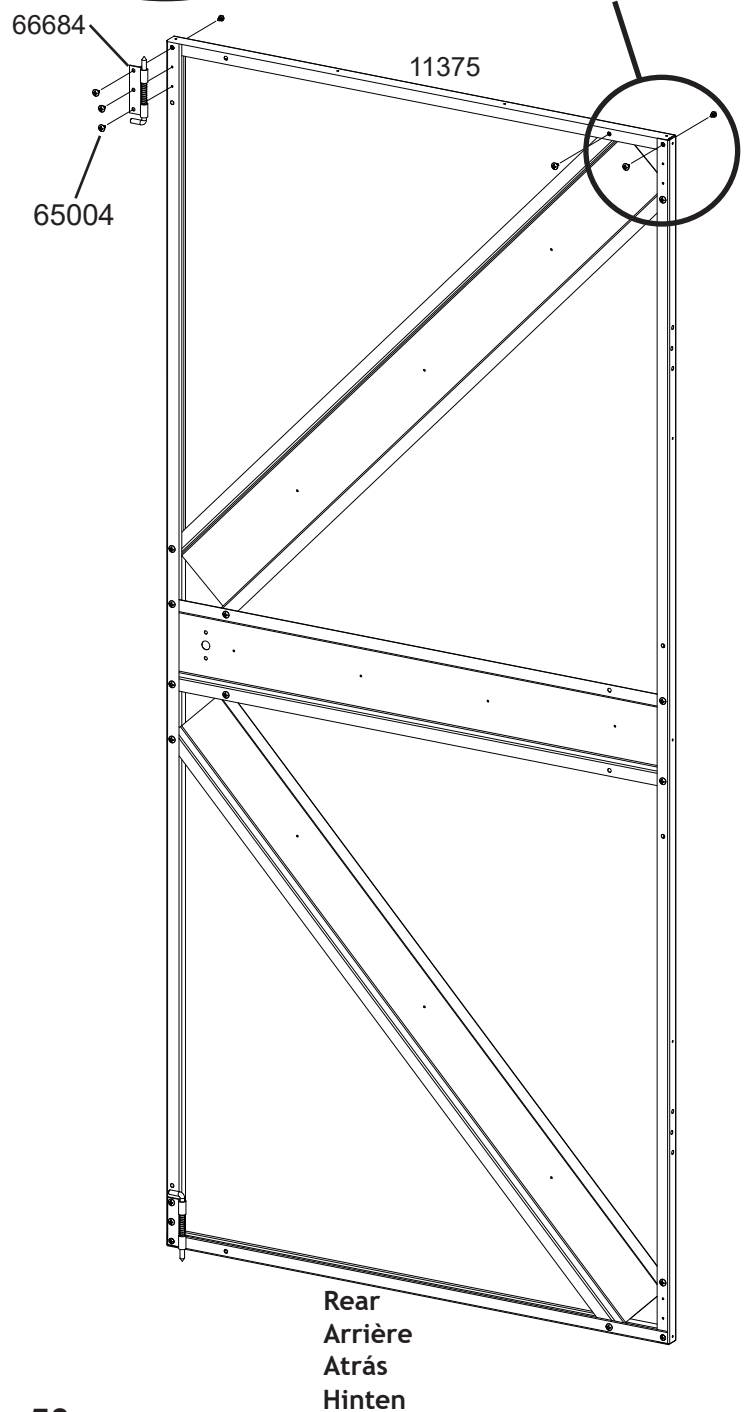
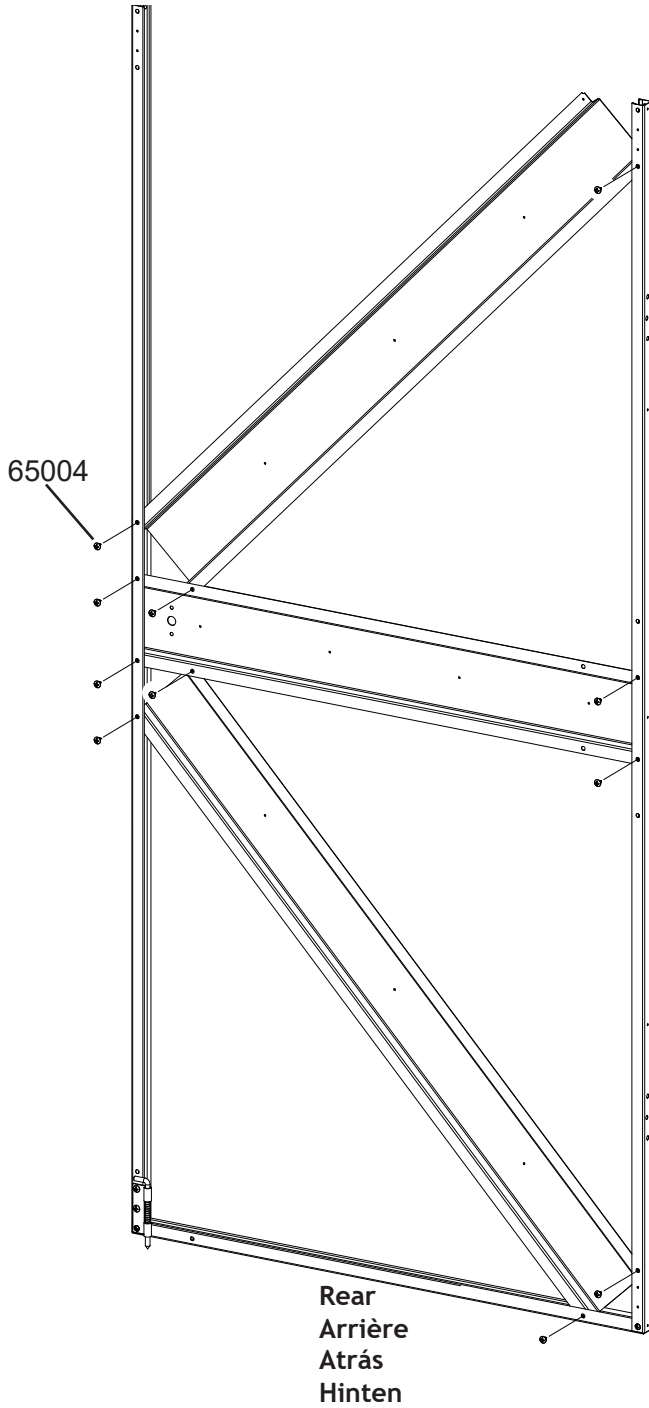
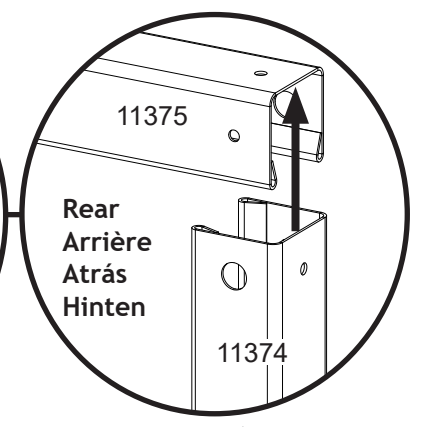
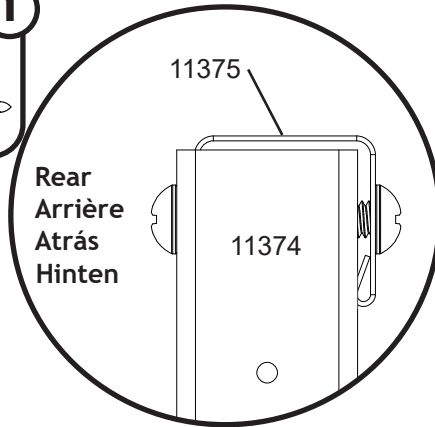
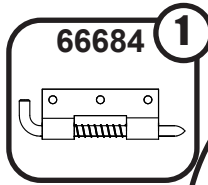
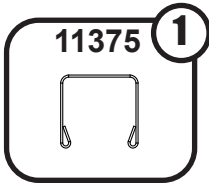
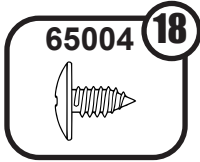

15: DOOR ASSEMBLY *PORTE ASSEMBLÉE* *ENSAMBLAJE DE LA PUERTA MONTAGE DER TÜRE*

48HUa

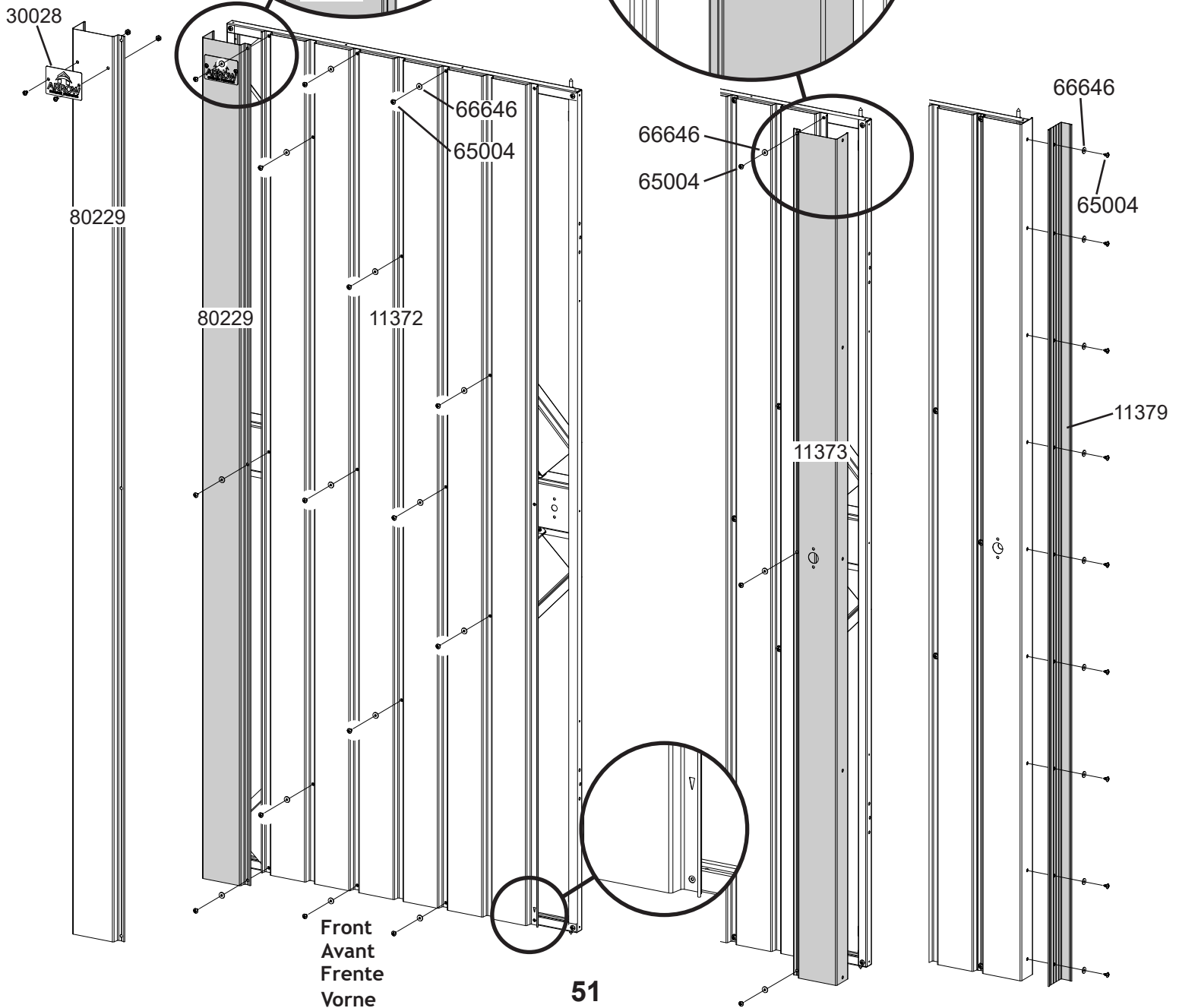
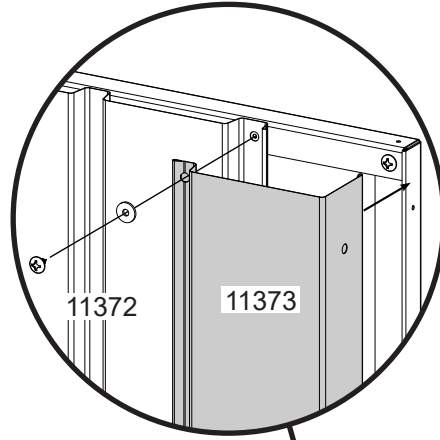
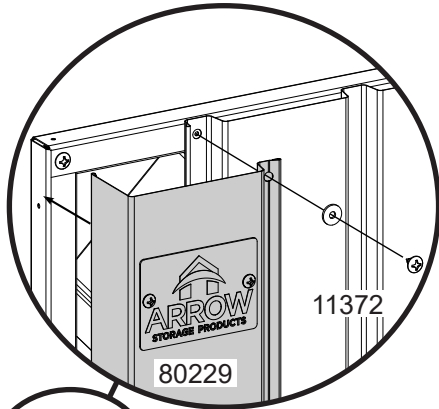
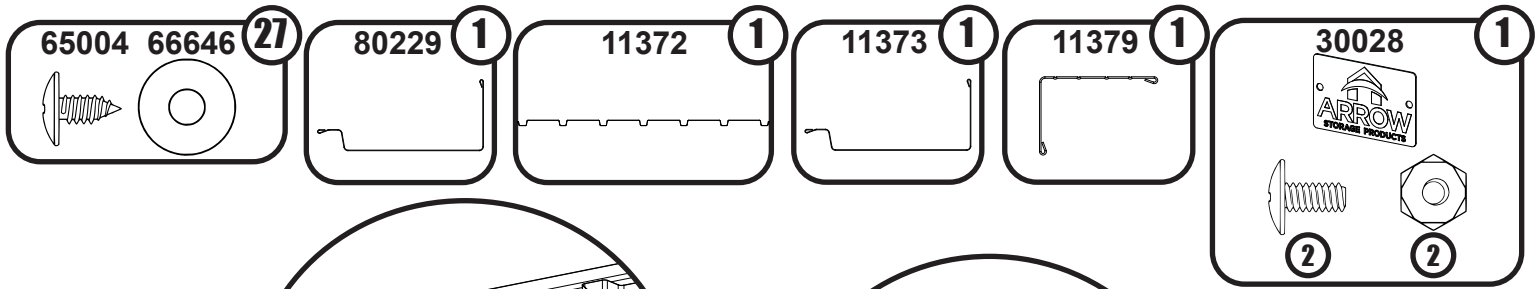

15: DOOR ASSEMBLY *PORTE ASSEMBLÉE* *ENSAMBLAJE DE LA PUERTA MONTAGE DER TÜR*

49HUb

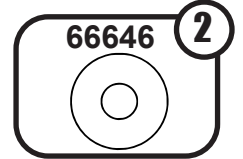
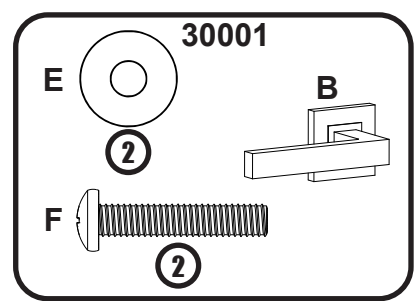
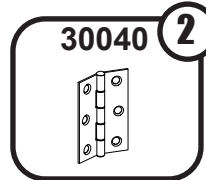
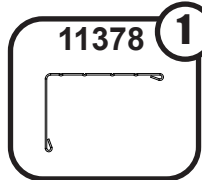
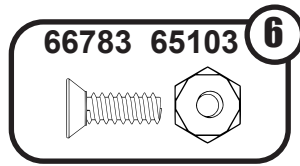
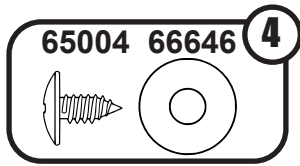

Left Door Assembly

Ensemble de porte gauche

Ensamblaje de la puerta izquierdo

Montage der linken Tür

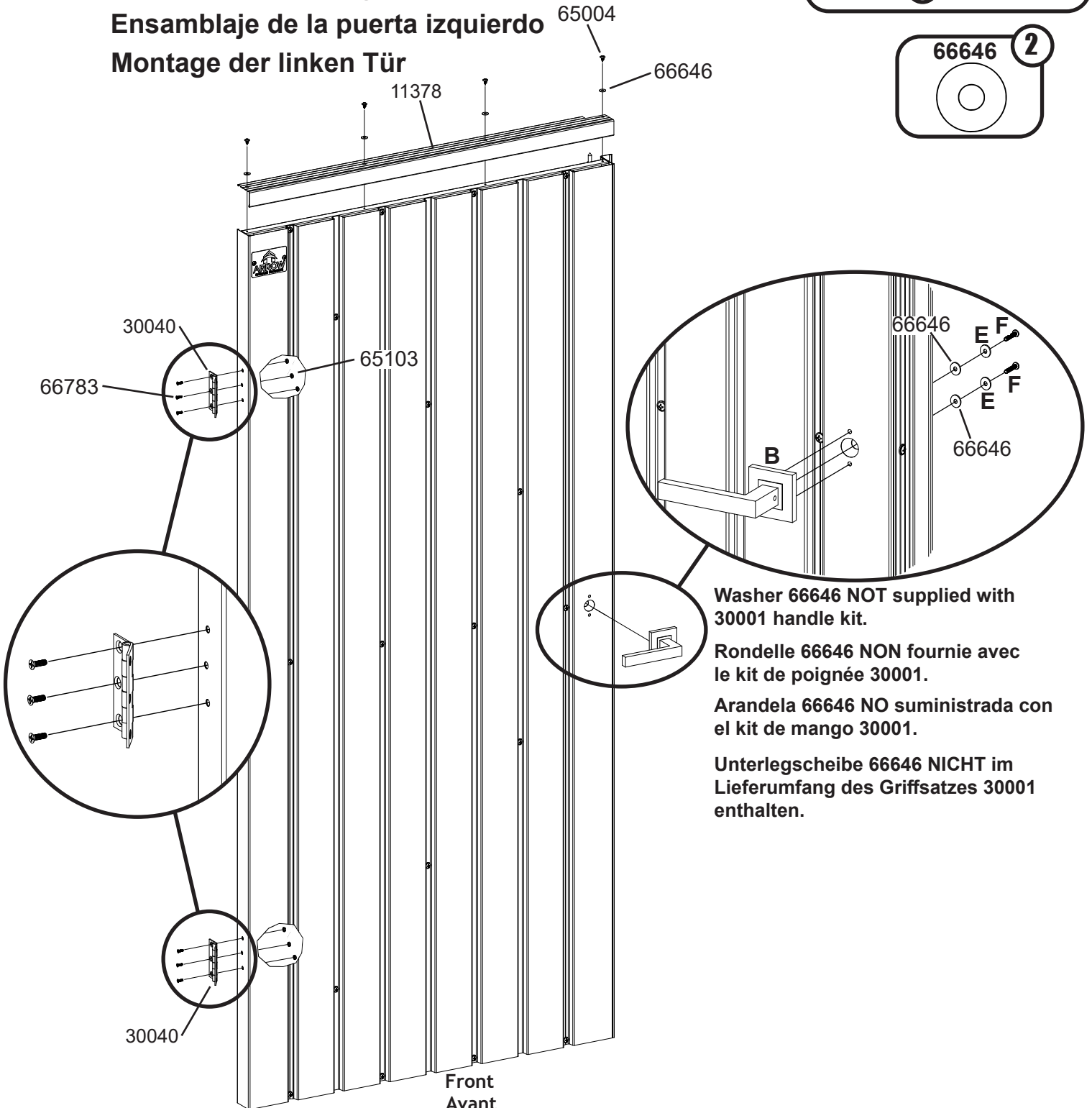

Washer 66646 NOT supplied with 30001 handle kit.

Rondelle 66646 NON fournie avec le kit de poignée 30001.

Arandela 66646 NO suministrada con el kit de mango 30001.

Unterlegscheibe 66646 NICHT im Lieferumfang des Griffsatzes 30001 enthalten.

Front
Avant
Frente
Vorne

15: DOOR ASSEMBLY

PORTE ASSEMBLÉE

ENSAMBLAJE DE LA PUERTA MONTAGE DER TÜR

EN,FR,SP,GE-53Mca

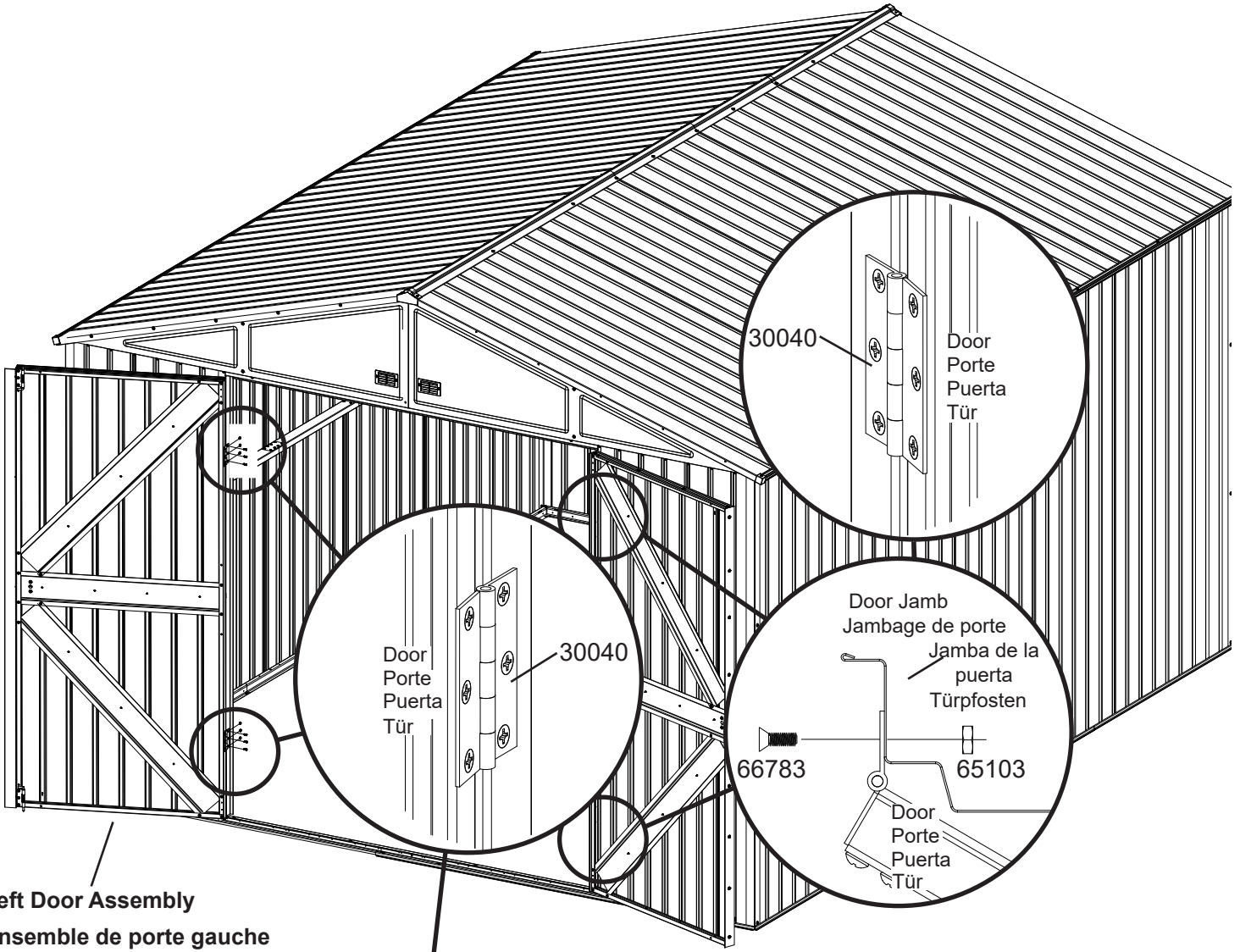
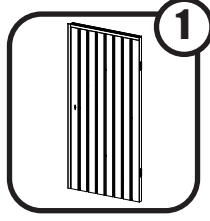
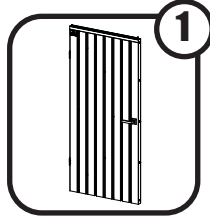
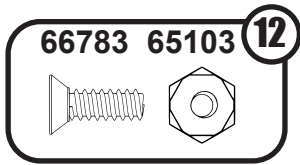

Left Door Assembly
Ensemble de porte gauche
Ensamblaje de la puerta izquierdo
Montage der linken Tür

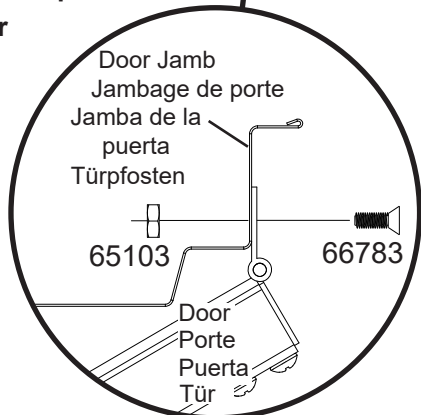

Right Door Assembly
Ensemble de porte droite
Ensamblaje de la puerta derecha
Montage der rechten Tür

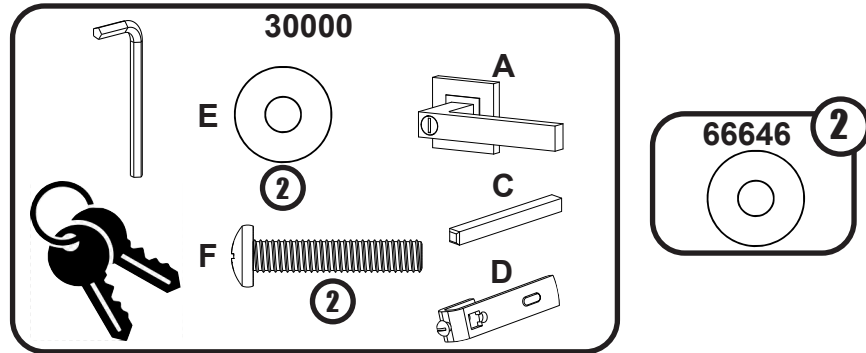

Right Door Assembly
Ensemble de porte droite
Ensamblaje de la puerta derecha
Montage der rechten Tür

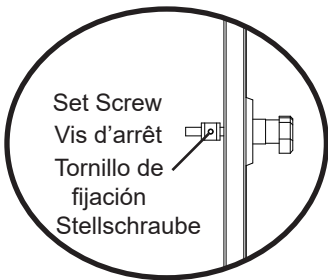
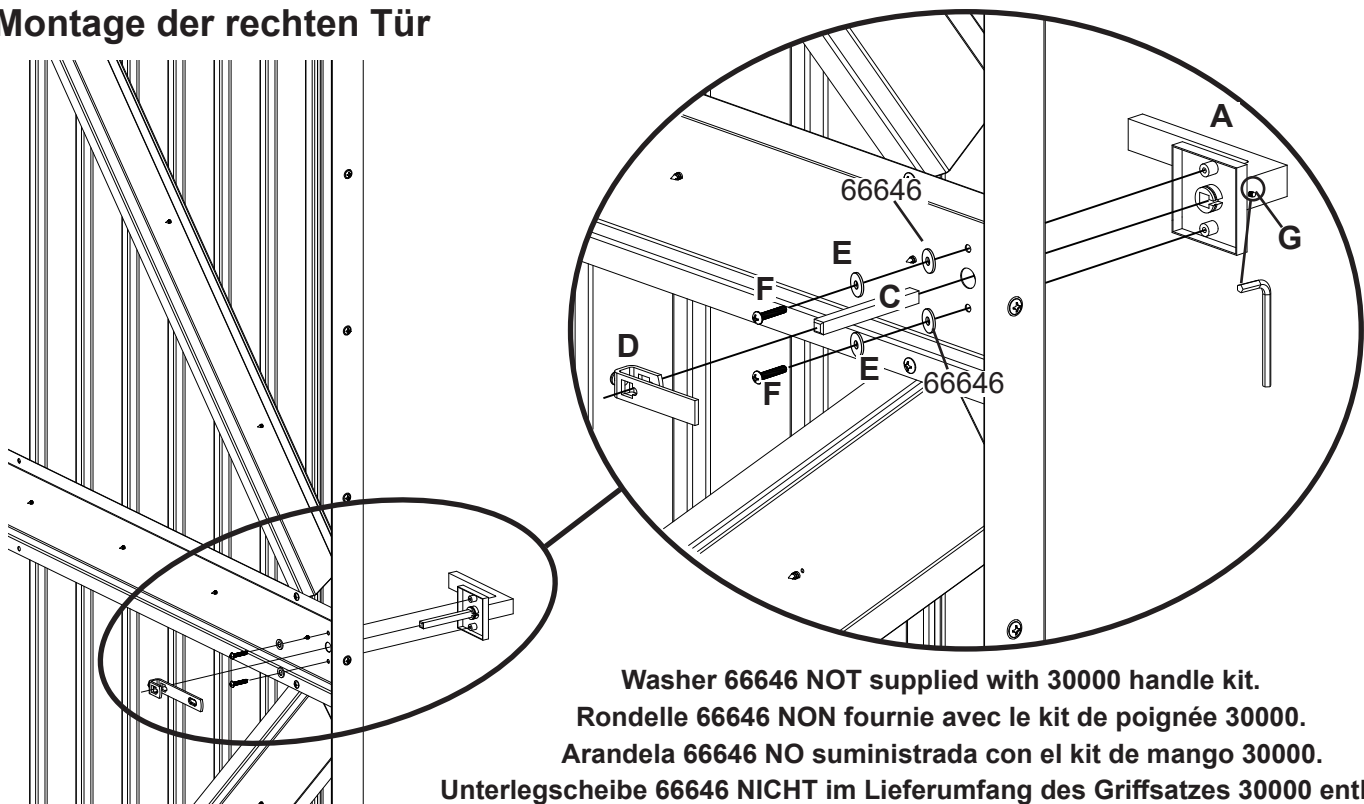

Close doors. Adjust so that latch engages behind door jamb, then tighten set screw. The unit is locked. Turn key and remove.

Ajuster de manière à ce que le loquet s'enclenche derrière la Jambage porte puis serrer la vis d'arrêt.

Cierre la puerta. Ajuste de manera que el cerrojo se enganche detrás de la Jamb de la puerta, luego apriete el juego de tornillos. La unidad está trancada. Voltee la llave y la retira.

Schließen Sie die Türen. Nehmen Sie Anpassungen vor, sodass die Verriegelung hinter der linken Tür einrastet, dann ziehen Sie die Stellschraube fest. Die Einheit ist abgeschlossen. Drehen Sie den Schlüssel um und ziehen Sie ihn heraus.

*** IMPORTANT ***

- *If you have swing doors, they must hang and swing level before anchoring building.*
- *Anchor your building at this time. Use appropriate 1/4"(6mm) X 1 1/2"(38,1mm) length hardware.*
- *Please take a moment to ensure that the building is installed in accordance with these instructions and with all applicable regulations.*
- *The entire floor frame MUST be securely anchored once the building is erected.*

*** IMPORTANT ***

- *Si l'abri comporte des portes battantes, vérifier qu'elles sont accrochées de niveau et pivotent librement avant d'ancrer l'ouvrage.*
- *Ancrez votre bâtiment en ce moment. Utilisez une longueur appropriée de 1/4 po (6 mm) X 1 1/2 po (38,1 mm) Matériel.*
- *Veiller à bien s'assurer que l'abri est installé conformément aux présentes instructions et à toute la réglementation en vigueur.*
- *Le cadre de plancher entier doit IMPÉRATIVEMENT être solidement ancré une fois que l'abri est assemblé.*

*** IMPORTANTE ***

- *Si tiene puertas vaivén, estas deben colgar y moverse en forma pareja antes de sujetar el cobertizo.*
- *Ancle su edificio en este momento. Use una herramienta apropiada de 1/4 "(6 mm) X 1 1/2" (38,1 mm) de longitud.*
- *Dedique unos minutos a asegurarse de que la estructura está instalada de acuerdo con estas instrucciones y con las reglamentaciones vigentes.*
- *Se DEBE anclar todo el tirante del piso cuando la estructura está erguida.*

WICHTIG

- *Wenn Sie Schwingtüren haben, müssen diese sauber hängen und schwingen, bevor der Schuppen verankert wird.*
- *Verankern Sie Ihr Gebäude zu diesem Zeitpunkt. Verwenden Sie angemessene Teile der Länge 1/4"(6mm) X 1 1/2" (38,1mm).*
- *Bitte überprüfen Sie noch einmal, ob der Schuppen im Einklang mit dieser Anleitung und mit allen geltenden Vorschriften aufgestellt wurde.*
- *Nach Aufstellung des Geräteschuppens MUSS der gesamte Bodenrahmen sicher verankert werden.*

