

Gas Log Splitter

Operator's Manual



MODEL NUMBER

- | | | | |
|----------------------------------|-----------------------------------|----------------------------------|-----------------------------------|
| <input type="checkbox"/> H6028FB | <input type="checkbox"/> H6028FB0 | <input type="checkbox"/> H6028BR | <input type="checkbox"/> H6028BR0 |
| <input type="checkbox"/> H6033FB | <input type="checkbox"/> H6033FB0 | <input type="checkbox"/> H6033BR | <input type="checkbox"/> H6033BR0 |
| <input type="checkbox"/> H6038FB | <input type="checkbox"/> H6038FB0 | <input type="checkbox"/> H6038BR | <input type="checkbox"/> H6038BR0 |

SERIAL NUMBER

PURCHASE DATE

Both model number and serial number may be found on the main label. You should record both of them in a safe place for future use.

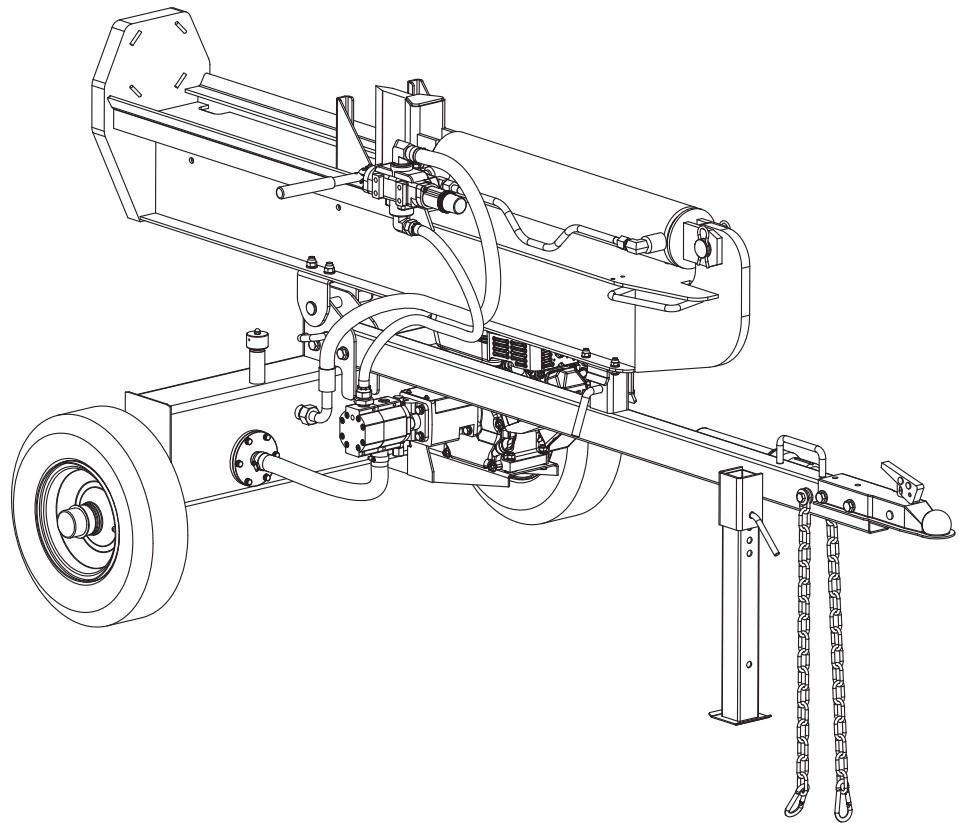

FOR YOUR SAFETY

READ AND UNDERSTAND THE ENTIRE MANUAL BEFORE OPERATING MACHINE

Your new FULL BOAR® gas log splitter offers quality construction, and is easy and safe to operate. Expect professional quality, and is easy and safe to operate. With proper use and care, it is designed to give you many years of dependable service.

Prepare to experience the durability to take on any job – with the ease, portability, and convenience of clean, gas splitting!

Discover the FULL BOAR Advantage

At FULL BOAR, we understand that land ownership definitely has its privileges, but it also comes with a great deal of responsibility. When duty calls and you need to respond, will you have what it takes to tame the great outdoors?

When looking for outdoor power equipment (OPE) to get the job done right, at the right price, FULL BOAR delivers the perfect combination of performance and practicality. FULL BOAR has a solution that's right for you.

MAX Performance, MAX Value, MAX Support

- ✓ Backed by decades of proven manufacturing expertise
- ✓ Enhanced design features come standard
- ✓ Engineered for the best user experience
- ✓ Quality metal parts are used instead of plastic
- ✓ A robust warranty supports all products
- ✓ Budget-friendly prices make it practical



Up for the job? FULL BOAR is.

TABLE OF CONTENTS

Introduction	1
Specifications	4
Symbols	6
Safety	7
Unpacking the Container	11
Contents Supplied	12
Assembly	14

Know Your Machine	26
Operation	28
Transporting	32
Maintenance	33
Storage	34
Troubleshooting	35
Parts Diagram	36

⚠ WARNING *Carefully read through this entire operator's manual before using your new unit. Pay attention to all cautions and warnings.*

This unit is a gasoline engine driven hydraulic log splitter. It is designed to split wood logs for use as firewood for a stove or fireplace. This log splitter will only split logs lengthwise with the grain.

ENGINE MANUAL

The **Engine Manufacturer** is responsible for all engine-related issues with regards to performance, power rating, specifications, warranty and service. Please refer to the **Engine Manufacturer's** owner/operator's manual, packed separately with your unit, for more information.

EMISSION CONTROL SYSTEM

This equipment or its engine may include exhaust and evaporative emission control system components required to meet U.S. Environmental Protection Agency (EPA) and/or California Air Resources Board (CARB) regulations. Tampering with emission controls and components by unauthorized personnel may result in severe fines or penalties. Emission controls and components can only be adjusted by an authorized engine manufacturer's service center.

CALIFORNIA PROPOSITION 65 WARNING

Engine exhaust, some of its constituents and certain product components contain or emit chemicals known to the state of California to cause cancer and birth defects or other reproductive harm. [For more information, go to www.P65Warnings.ca.gov.](http://www.P65Warnings.ca.gov)

ENVIRONMENTAL



Recycle unwanted materials instead of disposing of them as waste. All tools, hoses, and packaging should be resorted, taken to the local recycling center and disposed of in an environmentally safe way.

MODEL AND SERIAL NUMBERS

Record the model and serial number as well as date and place of purchase for future reference. Have this information available when ordering parts or optional accessories and when making technical or warranty inquiries.

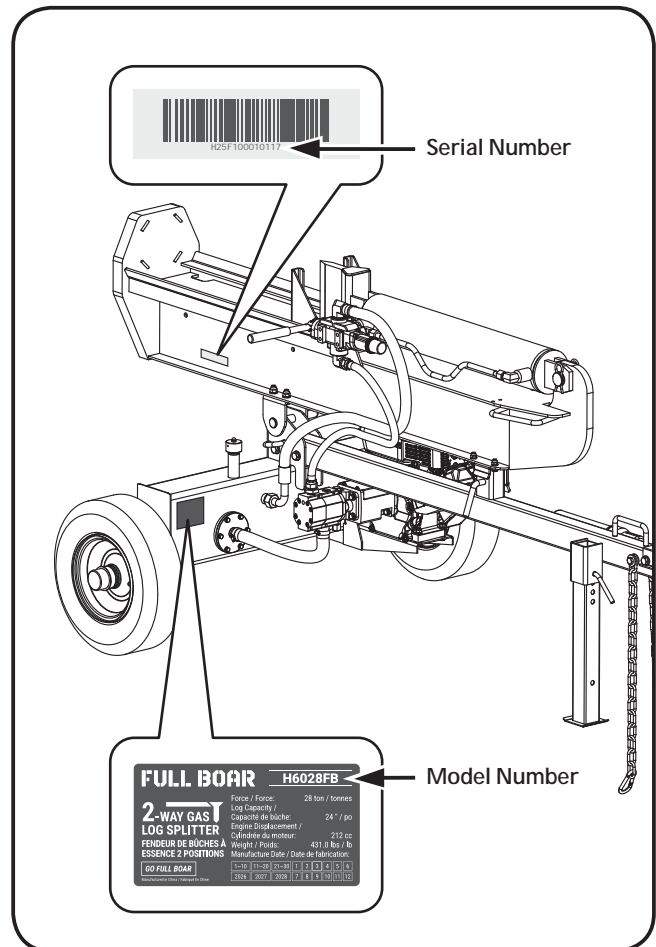

DISCLAIMER

Manufacturer reserves the right to discontinue, change, and improve its products at any time without notice or obligation to the purchaser. The descriptions and specifications contained in this manual were in effect at printing. Equipment described within this manual may be optional. Some illustrations may not be applicable to your unit.

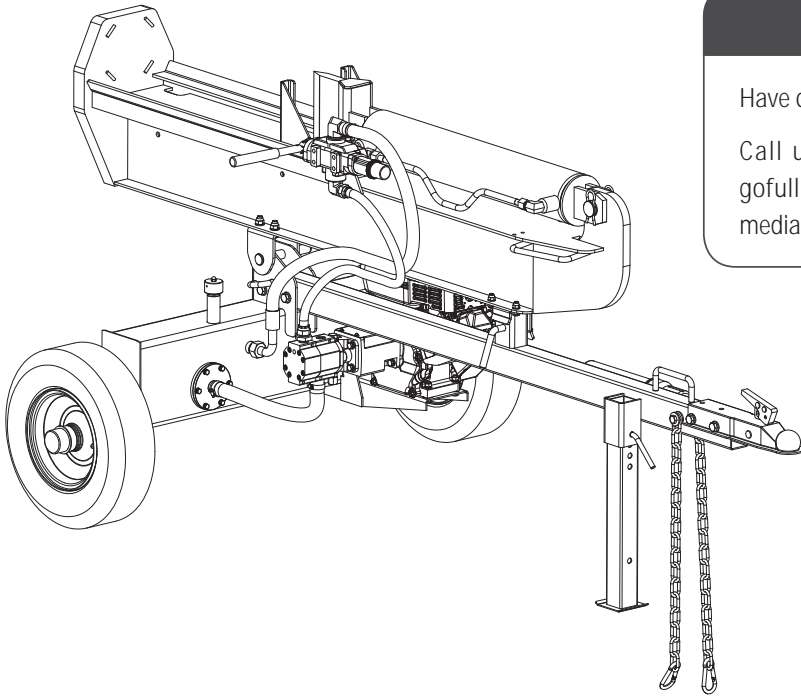

SUPPORT

Have questions about your FULLBOAR equipment?

Call us at (888) 533-2999, email us at Support@gofullboar.com, or contact us via your favorite social media site.

SPECIFICATIONS

Model #	H6028FB	H6028FBO	H6033FB	H6033FBO	H6038FB	H6038FBO
Splitting Force*	28 ton		33 ton		38 ton	
Log Capacity	24"					
Engine	Full Boar		Full Boar		Full Boar	
Displacement	212 cc		223 cc		306 cc	
Gross Torque	8.8 ft-lb / 2800rpm		9.7 ft-lb / 3000rpm		13.6 ft-lb / 3000rpm	
Fuel Capacity	0.95 Gallon		0.95 Gallon		1.58 Gallon	
Engine Oil Capacity	0.63 qts		0.63 qts		1.16 qts	
Starting System	Recoil					
Control Valve	Auto Return with Adjustable Detent					
Pump Size	14 GPM		14 GPM		17 GPM	
Hydraulic Cylinder Bore	4"		4.5"		5"	
Hydraulic Cylinder Stroke	22.75"		22.75"		22.75"	
Hydraulic Rod Diameter	1.75"		1.75"		2"	
Cylinder Cycle Time*	10.9 seconds		14.3 seconds		13.8 seconds	
Hydraulic Capacity	6.4 Gallon		6.9 Gallon		8.5 Gallon	
Hydraulic Oil Required to Fill	5.0 Gallon		5.3 Gallon		6.4 Gallon	
Hydraulic Oil Included	Included (for model H6028FBO, H6033FBO, H6038FBO only) Not Included (for model H6028FB, H6033FB, H6038FB only)					
Replacement Filters	Buit-in, Sealed, Return Filter, Suction Screen					
Beam	Heavy duty H-shape formed construction					
Wedge Size	7"					
Wedge Style	2-way					
Rear Wheels	4.80-8, DOT Approved 16" O.D. Road Tires					
Hitch Coupler	2" Ball with Safety Chains					
Safety Chains	Standard					
Max Towing Speed	45 mph					
Hitch Handle	Standard					
Horizontal/Vertical Splitting	Standard					
Open Operating Zone	Standard					
Log Table	Sold Separately					
Log Lift Table Attachment	Sold Separately					
Weight (lbs)	431.0 lbs	468.5 lbs	472.5 lbs	512.5 lbs	514.3 lbs	562.8 lbs
Dimensions (L × W × H) Inches	89.5" × 48" × 37"					

* Splitting force and cycle times may vary depending on mechanical and environmental conditions.

Model #	H6028BR	H6028BRO	H6033BR	H6033BRO	H6038BR	H6038BRO
Splitting Force*	28 ton		33 ton		38 ton	
Log Capacity	24"					
Engine	Briggs & Stratton, CR950		Briggs & Stratton, CR950		Briggs & Stratton, 1450	
Displacement	208 cc		208 cc		306 cc	
Gross Torque	9.5 ft-lb		9.5 ft-lb		14.7 ft-lb	
Fuel Capacity	0.80 Gallon		0.80 Gallon		1.40 Gallon	
Engine Oil Capacity	0.63 qts		0.63 qts		1.16 qts	
Starting System	Recoil					
Control Valve	Auto Return with Adjustable Detent					
Pump Size	14 GPM		14 GPM		17 GPM	
Hydraulic Cylinder Bore	4"		4.5"		5"	
Hydraulic Cylinder Stroke	22.75"		22.75"		22.75"	
Hydraulic Rod Diameter	1.75"		1.75"		2"	
Cylinder Cycle Time*	10.9 seconds		14.3 seconds		13.8 seconds	
Hydraulic Capacity	6.4 Gallon		6.9 Gallon		8.5 Gallon	
Hydraulic Oil Required to Fill	5.0 Gallon		5.3 Gallon		6.4 Gallon	
Hydraulic Oil Included	Included (for model H6028BRO, H6033BRO, H6038BRO only) Not Included (for model H6028BR, H6033BR, H6038BR only)					
Replacement Filters	Buit-in, Sealed, Return Filter, Suction Screen					
Beam	Heavy duty H-shape formed formed construction					
Wedge Size	7"					
Wedge Style	2-way					
Rear Wheels	4.80-8, DOT Approved 16" O.D. Road Tires					
Hitch Coupler	2" Ball with Safety Chains					
Safety Chains	Standard					
Max Towing Speed	45 mph					
Hitch Handle	Standard					
Horizontal/Vertical Splitting	Standard					
Open Operating Zone	Standard					
Log Table	Sold Separately					
Log Lift Table Attachment	Sold Separately					
Weight (lbs)	432.0 lbs	469.5 lbs	474.0 lbs	514.0 lbs	516.0 lbs	565.0 lbs
Dimensions (L x W x H) Inches	89.5" x 48" x 37"					

* Splitting force and cycle times may vary depending on mechanical and environmental conditions.

SYMBOLS

The rating plate on your machine may show symbols. These represent important information about the product or instructions on its use.

- 

Indicates a potential personal injury hazard.
- 

Read these instructions carefully.
- 

Wear eye protection.
- 

Wear hearing protection.
- 

Wear protective gloves.
- 

Wear safety footwear.
- 

Do not remove or tamper with the protection and safety devices.
- 

Don't stand or sit on the log splitter.
- 

Operate the log splitter on level surfaces. Stay off slopes and slippery surfaces.
- 

Do not touch parts that are hot from operation. Serious burns may result.
- 

No smoking, sparks, or flames.
- 

Properly dispose of waste oil!
- 

Keep children and bystanders off and away.
- 

Be sure the engine's switch is off before transporting the machine or performing any maintenance.
- 

Keep hands and fingers away from all pinch points.
- 

Never remove partially split wood from the wedge with your hands. Fingers may become trapped between the split wood.
- 

Keep hands away from moving parts. Moving parts can crush or cut.
- 

Keep feet away from moving parts. Moving parts can crush or cut.
- 

Keep hands away from the log stripper.
- 

Keep your hands away from the wedge and the cylinder, and away from any space in between.
- 

Always keep body and hands away from pin holes or nozzles that eject hydraulic fluid under pressure. Escaping hydraulic fluid can puncture skin and cause blood poisoning.
- 

Thrown objects.
- 

Check and fill hydraulic oil.
- 

Follow the direction indicated to use the control lever.
- 

For logs that are not cut square, the longest portion of the log should be rotated down and the most square end placed toward the end plate.
- 

Do not transport with objects on the machine.
- 

MAX. TOWING SPEED OF
VITESSE MAX. DE REMORQUAGE :
45 MPH

Maximum towing speed of 45 mph.

LOG LIFT TABLE ATTACHMENT (SOLD SEPARATELY)



Read and follow the lift table assembly steps and operating instructions in owner's manual.

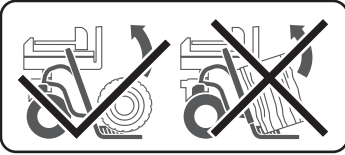

Wrong direction of the log may cause roll and fall when rise.

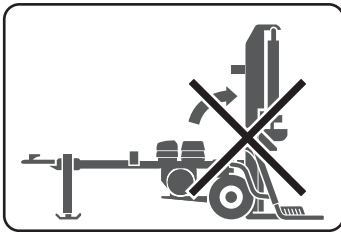

Vertical operating position is prohibited when the log lift table attachment is attached.

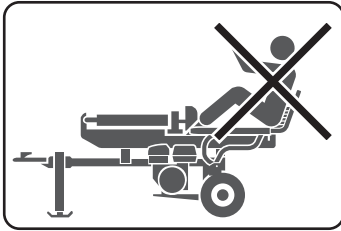

Do not sit on the log lift table.

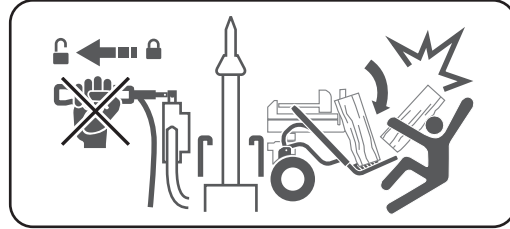

When the wedge is extended and not fully return back, do not pull the control lever outwards, otherwise the log lift table attachment may suddenly drop down, risks of falling the log, damage and injury.

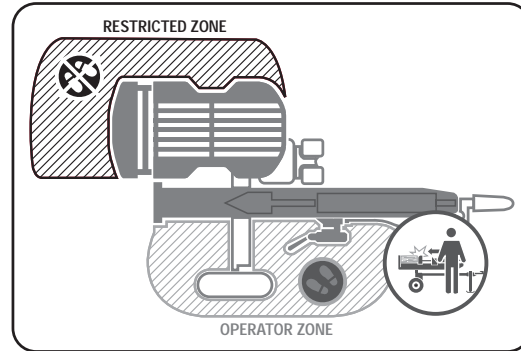

Always keep bystanders away at least 10 feet (3m) from this machine. Only one person should operate the log splitter and load the logs.

When the wedge or log lift table is moving, anybody including operator is prohibited to stand in the restricted zone.

SAFETY

SIGNAL SAFETY WORDS DEFINITION

The definitions below give the level of severity for each signal word.



DANGER

This symbol is used to indicate a hazardous situation which, if not avoided, will result in serious injury or death.



CAUTION

This symbol indicates a hazard, which, if not avoided, may result in minor injury, moderate injury, or property damage.



WARNING

This symbol points out safety instructions. Read and follow all instructions before attempting to operate this product. Failure to comply with these instructions could result in serious injury or death.



NOTE

This information makes the product easier to use.

GENERAL SAFETY RULES

UNDERSTAND YOUR MACHINE

Read this manual and labels affixed to the machine to understand its limitations and potential hazards.

Be thoroughly familiar with the controls and their proper operation. Know how to stop the machine and disengage the controls quickly.

Make sure to read and understand all the instructions and safety precautions as outlined in the **Engine Manufacturer's** manual packed separately with your unit. Do not attempt to operate the machine until you fully understand how to properly operate and maintain the engine and how to avoid accidental injuries and/or property damage.

If the unit is to be used by someone other than original purchaser or loaned, rented, or sold, always provide this manual and any needed safety training before operation. The user can prevent and is responsible for accidents or injuries that may occur to themselves, other people, and property.

Do not force the machine. Use the correct machine for your application. The correct machine will do the job more efficiently and safer at the rate it was designed.

PERSONAL SAFETY

Do not permit children to operate this machine at any time.

Keep children, pets, and other people not using the unit away from the work area. Be alert and shut off unit if anyone enters work area. Keep children under the watchful care of a responsible adult.

Do not operate the machine while under the influence of drugs, alcohol, or any medication that could affect your ability to use it properly.

Dress properly. Wear heavy long pants, boots, and gloves. Do not wear loose clothing, short pants, or jewelry of any kind. Secure long hair so it is above shoulder level. Keep your hair, clothing, and gloves away from moving parts. Loose clothes, jewelry, or long hair can be caught in moving parts.

Protect eyes, face, and head from objects that may be thrown from the unit. Always wear safety goggles or safety glasses with side shields when operating.

Wear appropriate hearing protection.

Always keep hands and feet away from all moving parts during operation. Moving parts can cut or crush body parts.

Always keep hands and feet away from all pinch points.

Do not touch parts that might be hot from operation. Allow parts to cool before attempting to maintain, adjust, or service.

Stay alert, watch what you are doing, and use common sense when operating the machine.

Do not overreach. Do not operate the machine while barefoot or when wearing sandals or similar lightweight footwear. Wear protective footwear that will protect your feet and improve your footing on slippery surfaces. Keep proper footing and balance at all times. This enables better control of the machine in unexpected situations.

INSPECT YOUR MACHINE

Check your machine before starting it. Keep guards in place and in working order. Make sure all nuts, bolts, etc., are securely tightened.

Never operate the machine when it is in need of repair or is in poor mechanical condition. Replace damaged, missing, or failed parts before using it. Check for fuel leaks. Keep the machine in safe working condition.

Do not use the machine if the engine's switch does not turn it on or off. Any gasoline powered machine that can't be controlled with the engine switch is dangerous and must be replaced.

Regularly check to see that keys and adjusting wrenches are removed from the machine area before starting it. A wrench or a key that is left attached to a rotating part of the machine may result in personal injury.

Avoid accidental starting. Be sure the engine's switch is off before transporting the machine or performing any maintenance or service on the unit. Transporting or performing maintenance or service on a machine with its switch on invites accidents.

If the machine should start to vibrate abnormally, stop the engine (motor) and check immediately for the cause. Vibration is generally a warning sign of trouble.

ENGINE SAFETY

This machine is equipped with an internal combustion engine. Do not use on or near any unimproved, forest covered, or brush covered land unless the exhaust system is equipped with a spark arrester meeting applicable local, state, or federal laws.

In the state of California, a spark arrester is required by law. Other states have similar laws. A spark arrester, if used, must be maintained in effective working order by the operator.

Never start or run the engine inside a closed area. The exhaust fumes are dangerous, containing carbon monoxide, an odorless and deadly gas. Operate this unit only in a well-ventilated outdoor area.

Do not tamper with the engine to run it at excessive speeds. The maximum engine speed is preset by the manufacturer and is within safety limits. See engine manual.

Keep a Class B fire extinguisher on hand when operating this log splitter in dry areas as a precautionary measure.

FUEL SAFETY

Fuel is highly flammable, and its vapors can explode if ignited. Take precautions when using to reduce the chance of serious personal injury.

When refilling or draining the fuel tank, use an approved fuel storage container while in a clean, well-ventilated outdoor area. Do not smoke, or allow sparks, open flames, or other sources of ignition near the area while adding fuel or operating the unit. Never fill the fuel tank indoors.

Keep grounded conductive objects, such as tools, away from exposed, live electrical parts and connections to avoid sparking or arcing. These events could ignite fumes or vapors.

Always stop the engine and allow it to cool before filling the fuel tank. Never remove the cap of the fuel tank or add fuel while the engine is running or when the engine is hot. Do not operate the machine with known leaks in the fuel system.

Loosen the fuel tank cap slowly to relieve any pressure in the tank.

Never overfill the fuel tank. Fill the tank to no more than 1/2" below the bottom of the filler neck to provide space for expansion as the heat of the engine can cause fuel to expand.

Replace all fuel tank and container caps securely and wipe up spilled fuel. Never operate the unit without the fuel cap securely in place.

Avoid creating a source of ignition for spilled fuel. If fuel is spilled, do not attempt to start the engine but move the machine away from the area of spillage and avoid creating any source of ignition until fuel vapors have dissipated.

When fuel is spilled on yourself or your clothes, wash your skin and change clothes immediately.

Store fuel in containers specifically designed and approved for this purpose.

Store fuel in a cool, well-ventilated area, safely away from sparks, open flames, or other sources of ignition.

Never store fuel or a machine with fuel in the tank inside a building where fumes may reach a spark, open flame, or any other source of ignition, such as a water heater, furnace, or clothes dryer. Allow the engine to cool before storing in any enclosure.

HYDRAULIC SYSTEM SAFETY

The hydraulic system of the machine requires careful inspection along with the mechanical parts. Be sure to replace frayed, kinked, cracked, or otherwise damaged hydraulic hoses or hydraulic components.

Hydraulic fluid can result in severe burns. Fluid in the hydraulic system can penetrate skin and result in serious injury or death. Be sure to stop the engine and relieve hydraulic pressure before doing any work on hydraulic parts.

Keep body and hands away from pin holes or nozzles that expel hydraulic fluid when under pressure. Use paper or cardboard, not hands, to search for leaks.

Ensure all hydraulic fluid connections are tight and all hydraulic hoses and lines are in good condition before applying pressure to the system.

Do not remove the cap from the hydraulic tank or reservoir while the machine is running. The tank could contain hot oil under pressure, which could result in serious injury.

Do not adjust the pressure setting on the hydraulic pump or valve.

If injured by escaping fluid, no matter how small the wound is, see a doctor at once. A typical injection injury may be a small wound that does not look serious. However, severe infection or reaction can result if proper medical treatment is not administered immediately by a doctor who is familiar with injection injuries.

SPECIFIC SAFETY RULES

PREPARATION OF THE LOG

Both ends of the log should be cut as square as possible to prevent the log from rotating out of the splitter during operation.

Never split logs greater than the specified log capacity.

Do not operate the log splitter on icy, wet, muddy, or slippery ground. Only operate your log splitter on level ground.



DANGER

Operating on a slope could cause the log splitter to roll over or logs to fall off the equipment, which could result in injury.

Do not move the log splitter over hilly or uneven terrain without a tow vehicle or adequate help.

Keep the work area free of clutter. Remove split wood from around the log splitter immediately after each use to avoid potential tripping.

OPERATOR ZONE

This unit is designed to be operated by one person located in the operator zone as shown in the following diagrams.

Operate the unit only when standing in the operator zone.

Always stop the unit and allow moving parts to stop before leaving operation zone. Do not leave a running unit unattended.

**WARNING**

Many accidents occur when more than one person operates the log splitter.

The adult who loads and stabilizes the log must be the person who operates the control handle.

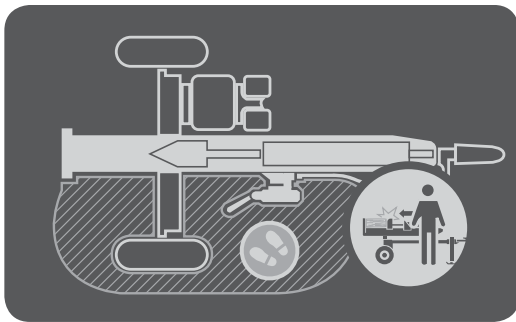
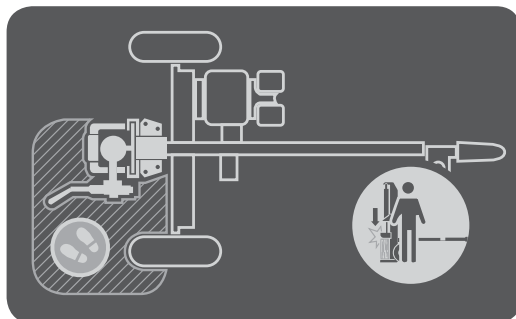
HORIZONTAL OPERATING POSITION**VERTICAL OPERATING POSITION****WARNING**

Vertical operating position is prohibited when the log lift table attachment is attached.

MACHINE USE AND CARE

Never operate the machine without good visibility or light.

Never attempt to split wood across the grain. The log splitter was not designed for cross-grain splitting.

Always block the front and back of both wheels to prevent unintended movement.

Hold the bark side of the logs when loading or positioning, never the ends. Never place your hands or any part of your body between a log and any part of the log splitter.

Do not straddle or step over the log splitter during operation.

Do not reach or bend over the log splitter to pick up a log.

When stabilizing a log with the left hand, remove your hand when the wedge contacts the log or serious injury may occur.

Never attempt to split more than one log at a time.

Do not attempt to load your log splitter when the ram or wedge is in motion.

Use your hand to operate the control lever on the valve. Do not use your foot, a rope, or any extension device.

Do not move the log splitter while the engine is running.

TOWING SAFETY

Check all local and state regulations regarding towing, licensing, and lights before towing your log splitter.

Before towing the log splitter, check tires for excessive wear, cuts, or damage. Check for proper tire inflation. Add air as required. Do not over inflate tires. Serious injury can result if tires explode.

Check before towing to make sure the log splitter is correctly and securely attached to the towing vehicle and the safety chains are secured to the hitch or bumper of the vehicle with enough slack to allow turning. Always use a class I, 2" ball with this log splitter.

Make sure the coupler is tight before towing and after towing 50 miles.

Never transport cargo on the log splitter.

Never allow anyone to ride or sit on the log splitter.

Always stop the engine, lock the beam in the horizontal position, and close the fuel shut-off valve when transporting the unit.

Use extra care when towing the log splitter. Do not exceed 45 mph. Towing the log splitter at a speed greater than 45 mph could result in loss of control, damage to the equipment, serious injury, or death.

Avoid sharp turns and steep angles. Avoid large holes or ditches when towing the equipment. Always be careful when backing up with your log splitter when towing; it could jackknife. Use caution when backing up; a spotter outside the vehicle is highly recommended. Disconnect the log splitter from the towing vehicle before operating it.

UNPACKING THE CONTAINER

Use the screwdriver and hammer to open all the side locks. Remove all the plywood plates. Remove all the loose parts on the bottom pallets. Use scissors or a knife to cut all the straps. (See *Figure 1a*)

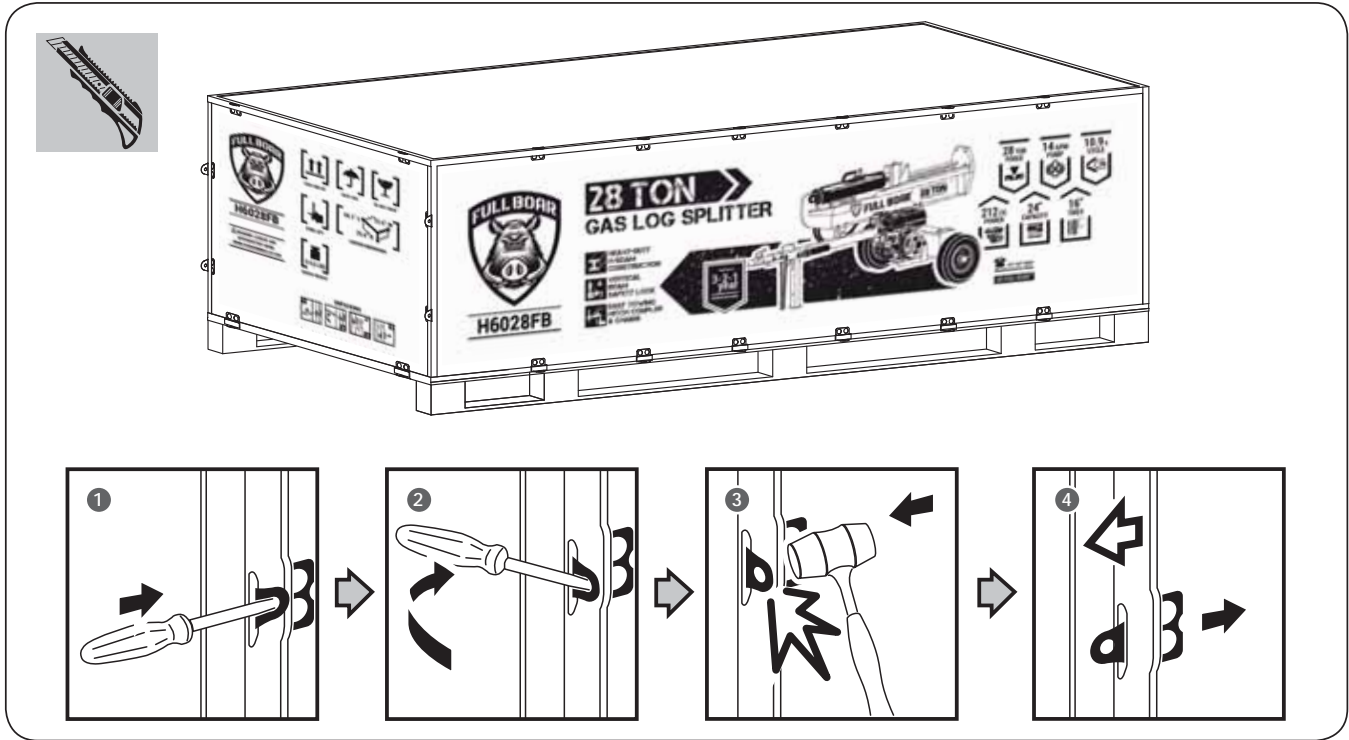

Figure 1a

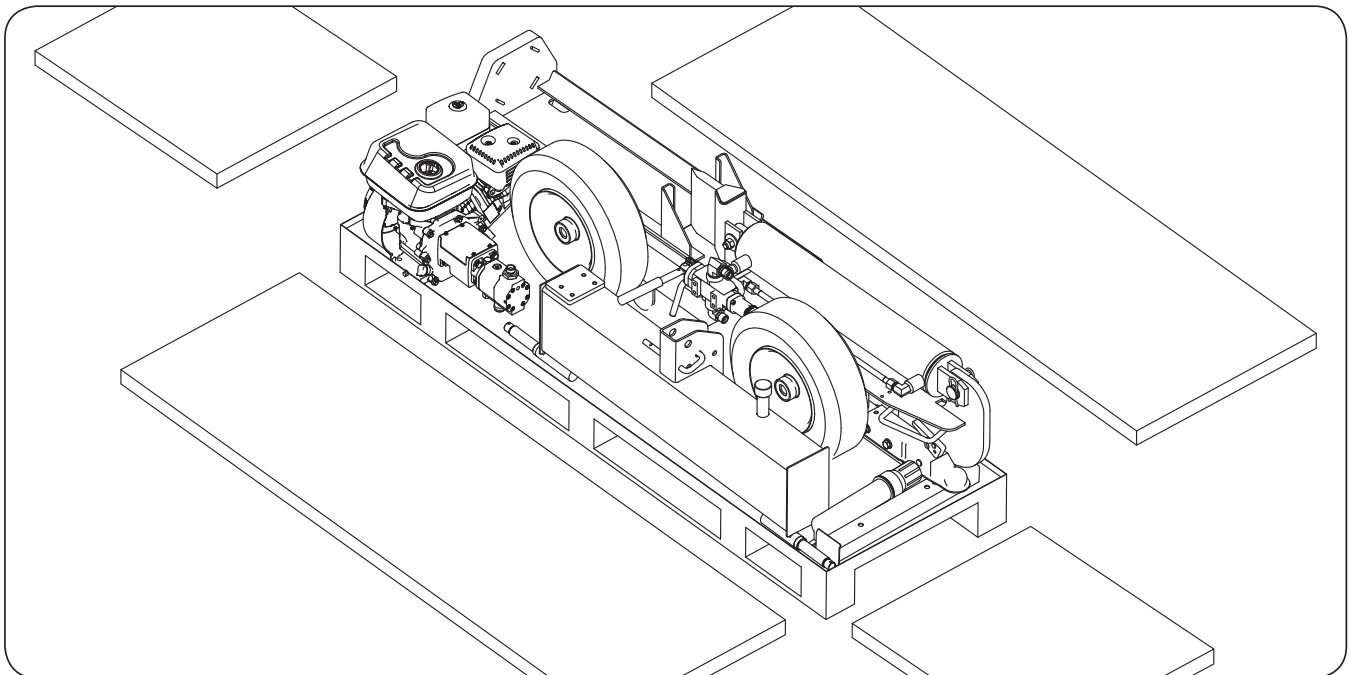

Figure 1b

CONTENTS SUPPLIED







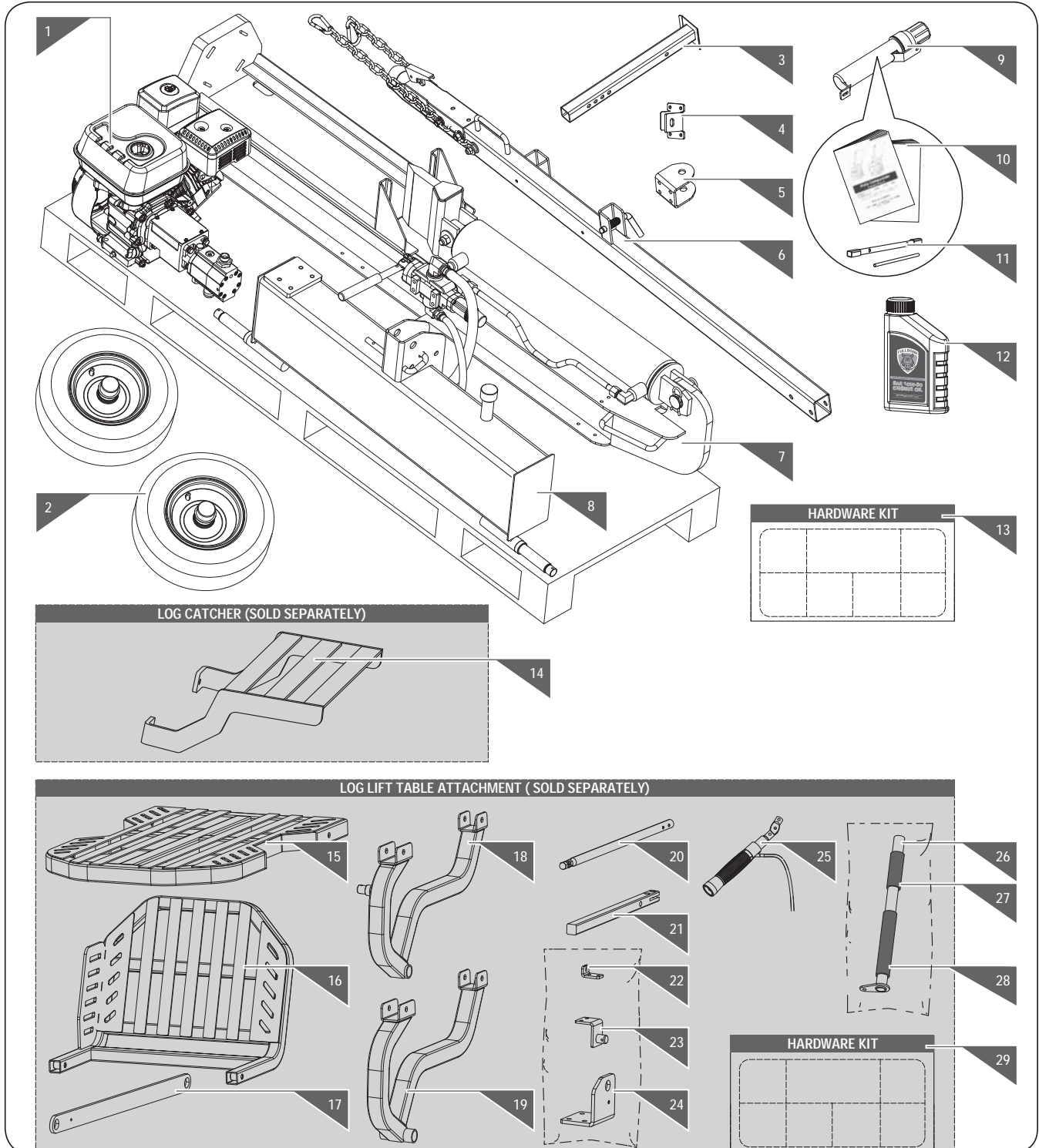





Your FULLBOAR log splitter comes partially assembled and contains the following:

! CAUTION

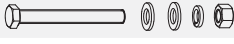
Heavy lifting required. Some of the components in these assembly instructions are heavy and can't be lifted by one person safely. Please plan to assemble this product when another person can be available to help.

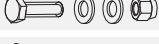

1. Engine
2. Wheels
3. Support Leg
4. Beam Lock Bracket
5. Pivot Bracket
6. Tow Bar
7. Beam with Cylinder
8. Reservoir
9. Manual Tube
10. Operator's Manual and Engine Manual
11. Tools for Spark plug Assembly
12. Engine Oil
13. Hardware Kit, Including:

	M22	× 1	1
	4 × 50	× 1	
		× 1	
	M22	× 1	2
	4 × 50	× 1	
		× 1	
	M12 × 85	× 2	3
	Bridge Pin	× 1	4
	Latch Pin	× 1	
	M8 × 25	× 4	5
	M10 × 30	× 4	
	20 × 145	× 1	6
	Bridge Pin	× 1	

FOR H6028FB / H6028FBO / H6028BR / H6028BRO / H6033FB / H6033FBO / H6033BR / H6033BRO ONLY

	M8 × 40	× 4	7
---	---------	-----	---

FOR H6038FB / H6038FBO / H6038BR / H6038BRO ONLY

	M10 × 45	× 4	7
---	----------	-----	---

	M8 × 20	× 2	8
---	---------	-----	---











LOG CATCHER (SOLD SEPARATELY)

14. Log Catcher

	M10 × 30	× 2	1
--	----------	-----	---

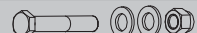
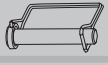
LOG LIFT TABLE ATTACHMENT (SOLD SEPARATELY)

15. Log lift table attachment-main table
16. Log lift table attachment-side table
17. Swing Arm
18. Support Leg (left)
19. Support Leg (right)
20. Ejector Rod
21. Slide-rail
22. Cable Fixing Plate
23. Bending Plate
24. Connecting Plate
25. Log lift table handle (shorter)
26. Rotating Shaft
27. Short Bushing
28. Long Bushing
29. Hardware Kit, Including:

	M6 × 20	× 2	1
	M6 × 25	× 2	2
		× 1	3
	M6 × 20	× 1	
	M8 × 16	× 2	4
	M10 × 20	× 4	5
	M10 × 70	× 3	6
	10 × 60	× 2	
	M8 × 20	× 1	7
	25 × 20 × 8	× 2	8
	φ 20	× 2	
	5 × 35	× 2	

ASSEMBLY

This log splitter was partially assembled at the factory. To assemble your machine follow the below instructions.

PREPARATION

1. Remove the engine from the pallet. (Remove the two bolts and nuts, See *Figure 2a.*)

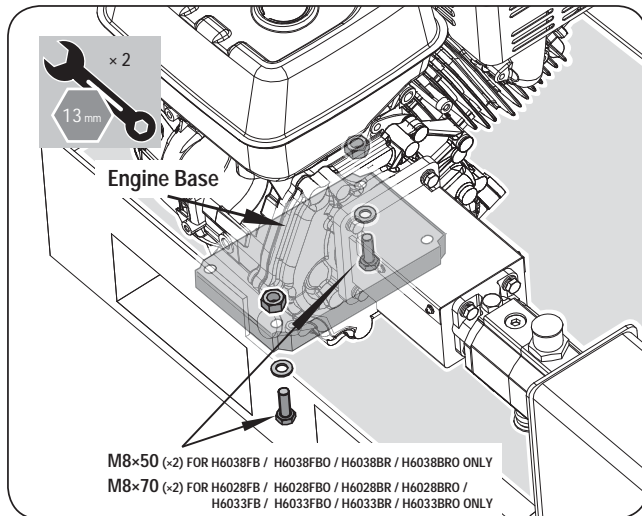

Figure 2a

2. Remove the Beam from the pallet. (Remove the two bolts and nuts, See *Figure 2b.*)

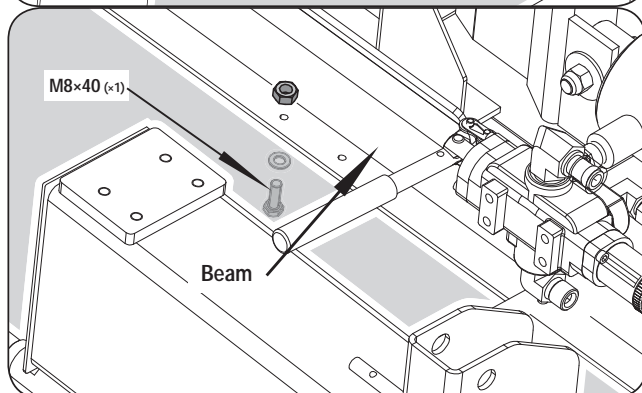
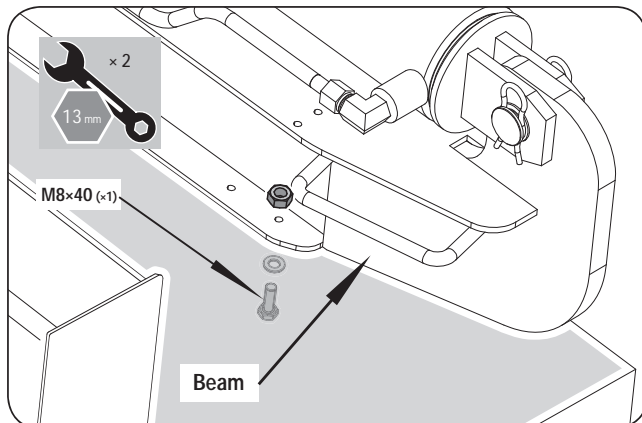

Figure 2b

WHEELS

1. Remove the anti-dust sleeves from the wheels. Take the roller bearings from the wheels and set aside for later use. (See *Figure 3a.*)

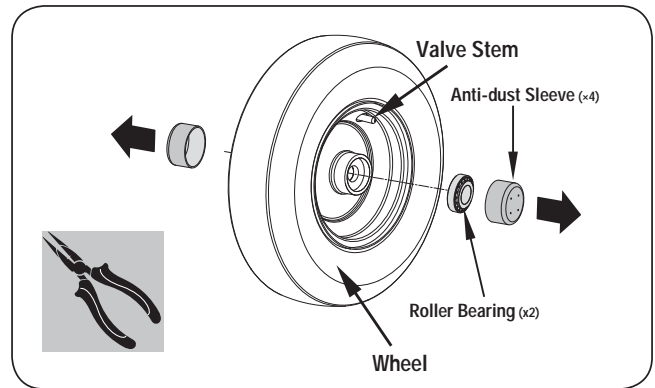

Figure 3a

2. Move the reservoir and let the side wheel axle outside of the pallet. (See *Figure 3b.*)

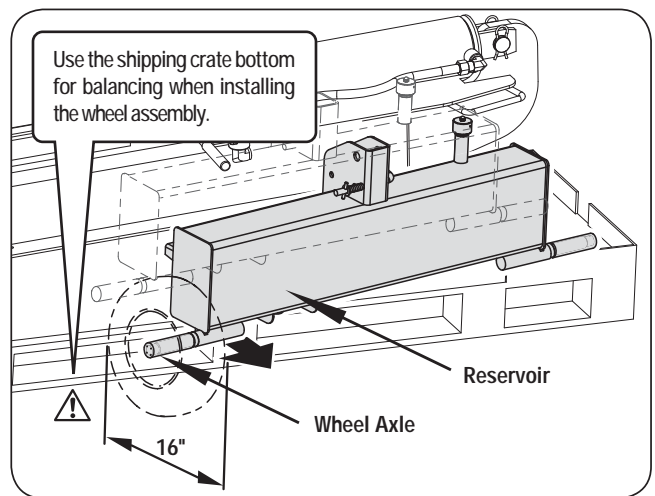

Figure 3b

3. Remove the two anti-dust sleeves from the wheel axle. (See *Figure 3c.*)

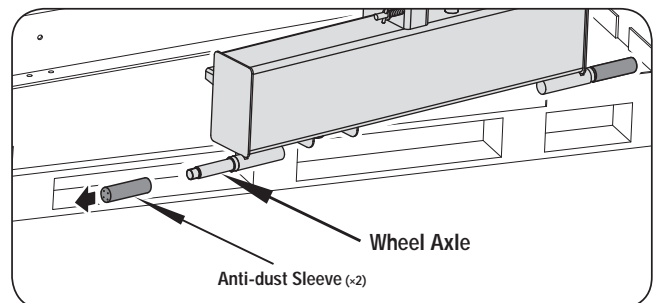

Figure 3c

- Slide the wheel with the valve stem facing out to the wheel axle and the roller bearing, then put the wheel washer against the bearing. Use a 32mm socket to tighten the axle nut completely. (See **Figure 3d**)

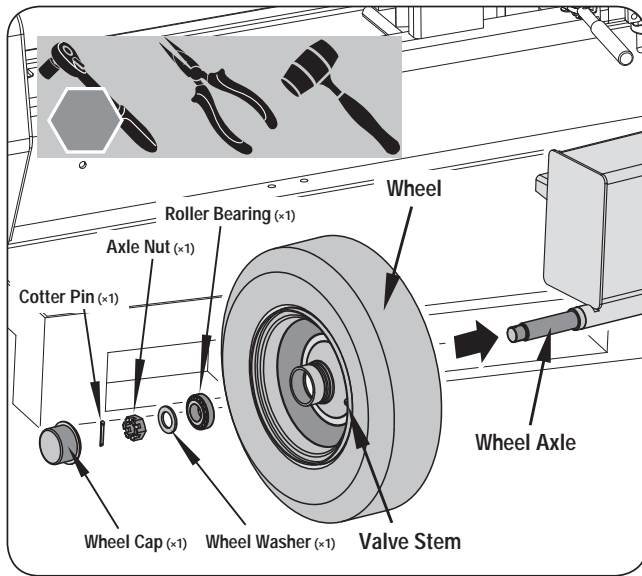

Figure 3d

	M22	x 1	1
	4 x 50	x 1	
		x 1	

- Spin the wheel clockwise or counterclock wise to ensure proper bearing seating.
- Turn the wheel with your fingers. If it feels too tight, loosen the axle nut slightly until the wheel turns smoothly.
- Insert the cotter pin through the hole in the axle. Bend open and spread the prongs in opposite directions so the axle nut will not come off (make sure the tire spins freely).

CAUTION *Installation of the cotter pin is important and required. Failure to install the cotter pin can result in loss of wheel retention. Always assemble using a new cotter pin. Do not reuse.*

- Place the wheel cap into the wheel cap installer, align it against the wheel hub, and use a soft-faced hammer to tap the installer lightly until the wheel cap is fully seated on the wheel hub. Then remove the installer.

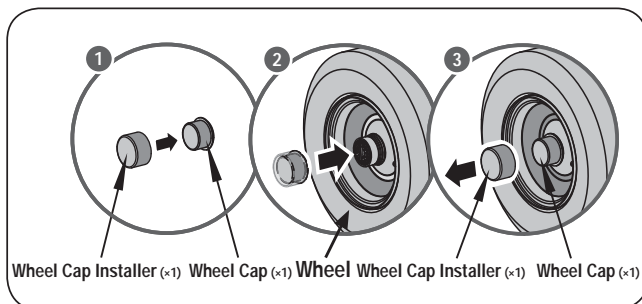

- Move the reservoir and let the other side wheel axle outside of the pallet. (See **Figure 3e**)

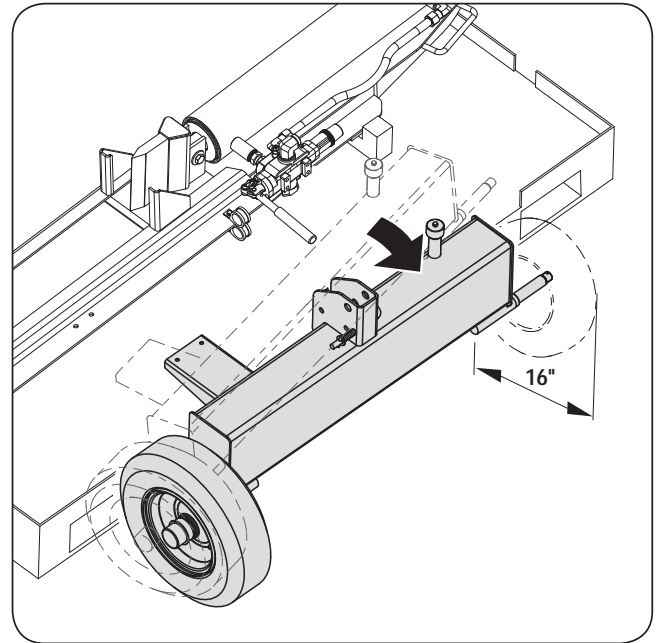

Figure 3e

- Follow the same procedure to assemble the other wheel (follow steps 4 – 8 under wheel assembly.) (See **Figure 3f**)

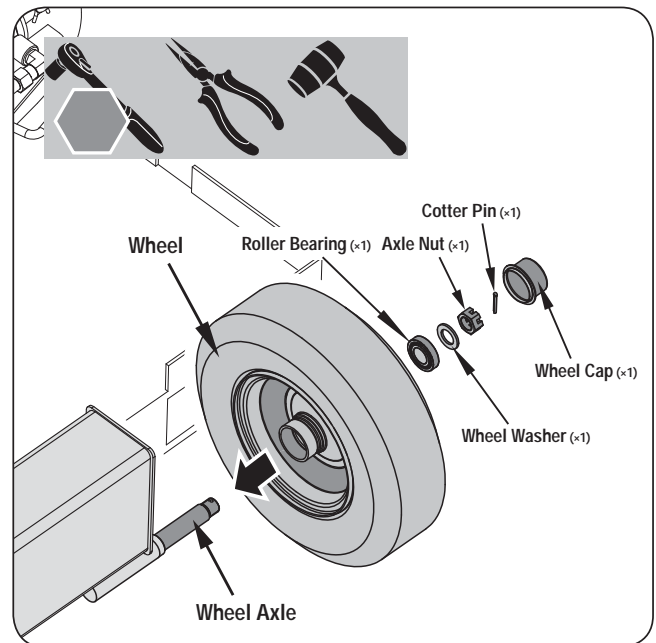

Figure 3f

	M22	x 1	2
	4 x 50	x 1	
		x 1	

BEAM

1. Hold and pull the beam outside the pallet. (See *Figure 4, Illustration 1.*)
2. Slowly lift the top of the beam and stand the beam on the end plate in the vertical position. (See *Figure 4, Illustration 2.*)

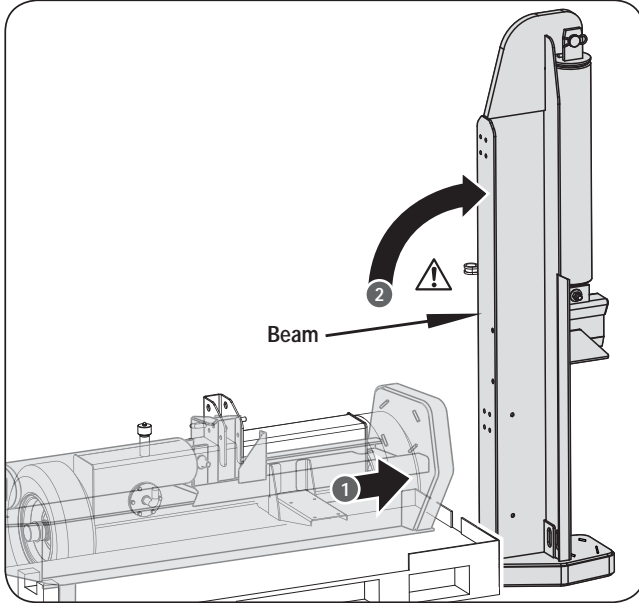

Figure 4

⚠ WARNING After the beam and cylinder assembly is in the vertical position, a helper is needed to prevent the beam from tipping over until it is secured on the hydraulic tank assembly with the lock pin.

The beam assembly is heavy and has a small foot print. When in the vertical position, the beam may fall, causing damage to the machine and could result in personal injury.

TOW BAR

Insert the tow bar into the tank pivot mount. Align the holes in the tow bar with the holes in the tank pivot mount. Connect and tighten the tow bar to the tank by using the M12×85 bolts, flat washers, spring washer, and nuts. (See *Figure 5.*)

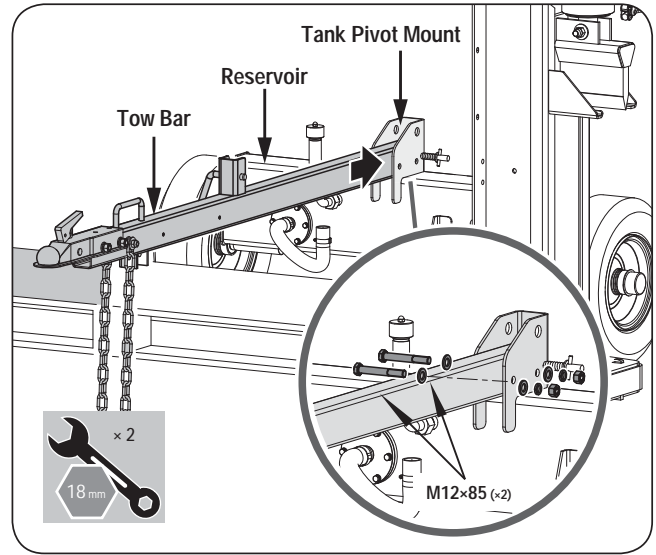



Figure 5

	M12 × 85	× 2	3
---	----------	-----	----------

SUPPORT LEG

Lift the tow bar slightly. Fix the support leg with tow bar by a latch pin and a bridge pin. Remove the bottom pallet. (See *Figure 6.*)

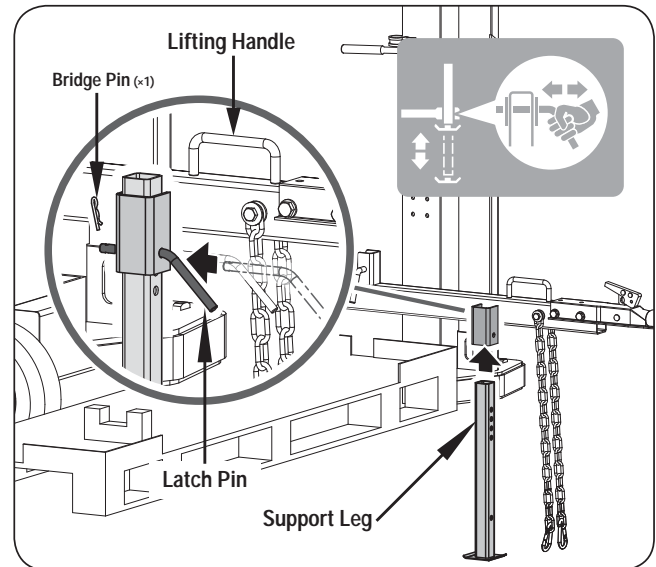



Figure 6

	Bridge Pin	× 1	4
	Latch Pin	× 1	

PIVOT BRACKET

1. Install the beam lock bracket to the beam by using the M8x25 bolts, spring washers, and flat washers. (See *Figure 7, illustration 1.*)
2. Align the holes in the pivot bracket with the holes on the beam and insert and tighten bolts, spring washers, and flat washers. (See *Figure 7, illustration 2.*)



DANGER

The beam can be very heavy and dangerous if that it tips over and may cause personal injury.

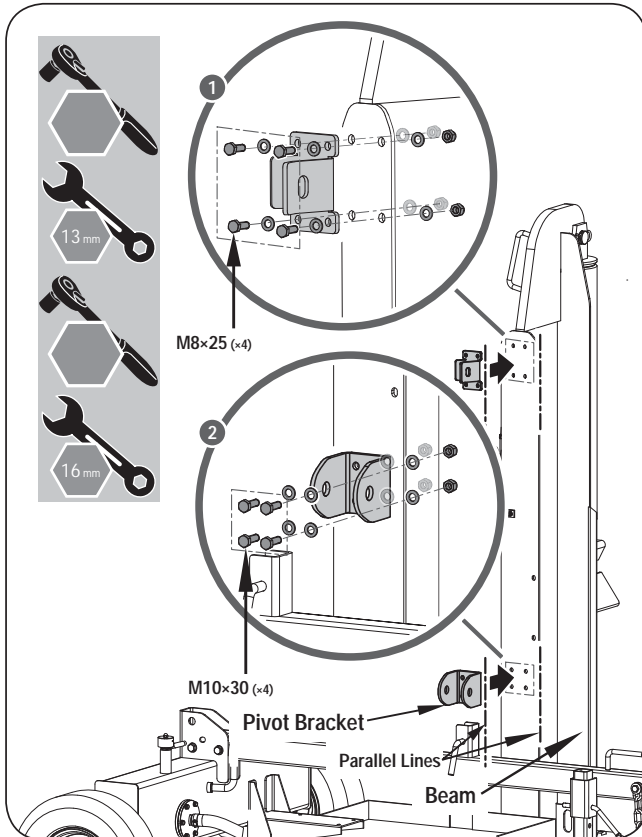

Figure 7

	M8 x 25	x 4	5
	M10 x 30	x 4	

BEAM TO RESERVOIR

1. Make sure a helper holds on to the beam to keep it from falling. Reposition the beam and reservoir so the back of the tank is facing the vertical beam as shown in *Figure 8a*.

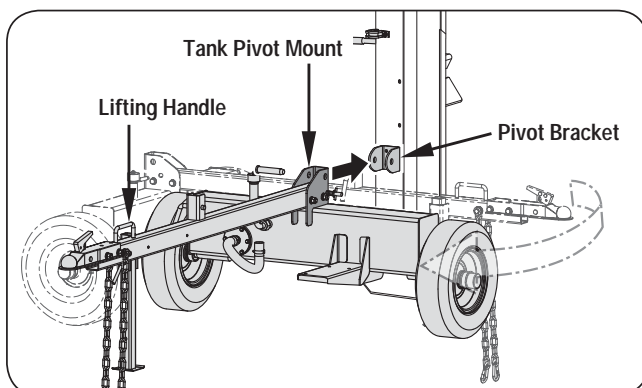

Figure 8a

2. Align the pivot bracket on the beam assembly to the pivot mount on the tank weldment and insert the beam pivot pin and washer. (See *Figure 8b*.)
3. Insert the bridge pin through the hole in the beam pivot pin.

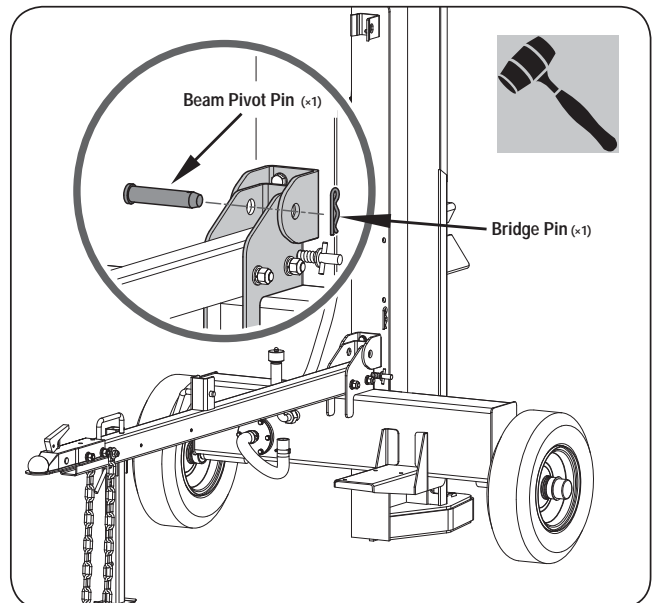

Figure 8b

	20 x 145	x 1	6
	Bridge Pin	x 1	

4. Pull the lock pin and rotate the lever to hold the beam. (See *Figure 8c*.)

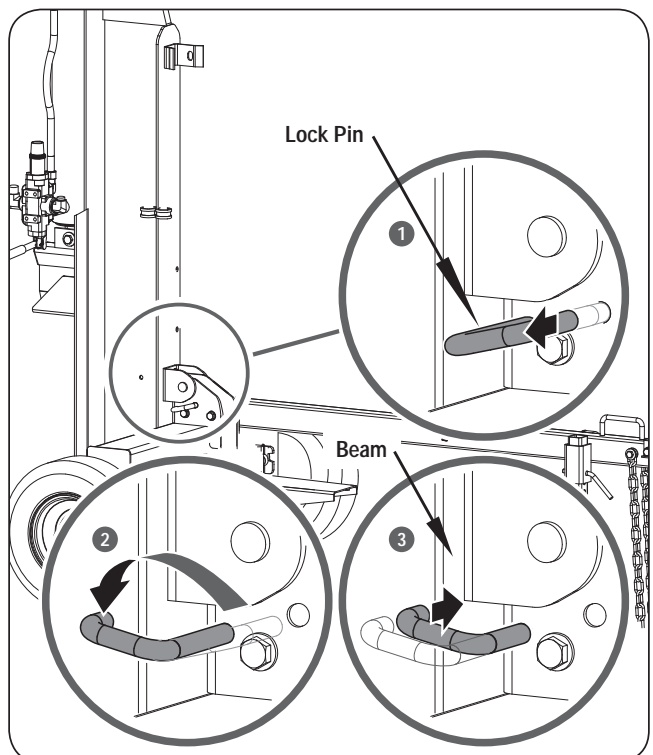

Figure 8c

ENGINE

1. Attach the engine to the engine mount plate on the reservoir by using bolts, flat washers, spring washers and nuts. (See *Figure 9a.*)

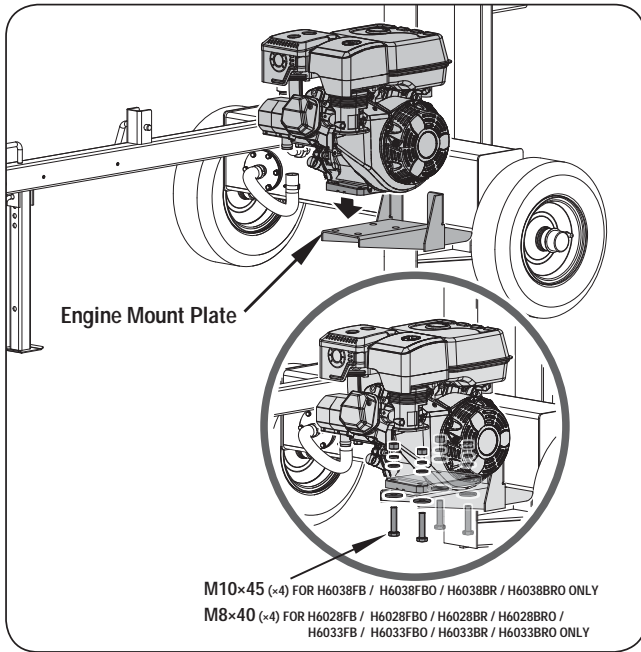
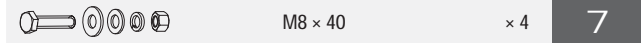

Figure 9a

FOR H6028FB / H6028FBO /
H6028BR / H6028BRO /
H6033FB / H6033FBO /
H6033BR / H6033BRO ONLY



M8 × 40

× 4

7

FOR H6038FB / H6038FBO /
H6038BR / H6038BRO ONLY

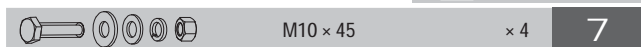

M10 × 45

× 4

7

3. Pull out the lock pin back to the home position. (See *Figure 9b.*)
4. Hold the lifting handle and slowly lower the beam. It will lock automatically. Double check to make sure the lock pin is locked onto the beam.

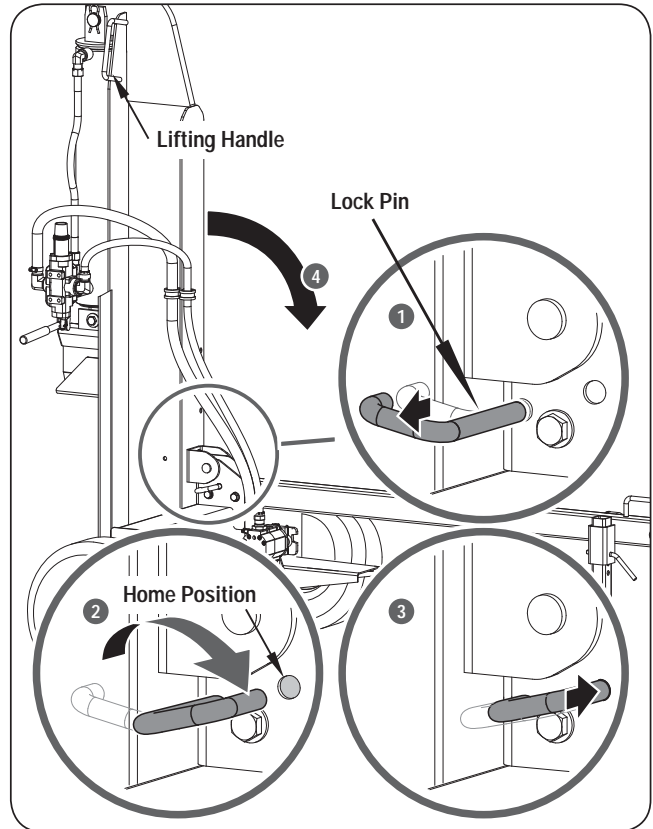

Figure 9b

! DANGER

Do not let the beam suddenly drop. Keep hands and fingers clear of pinch or crush points at all times.

5. Remove the anti-dust cap and anti-dust plugs from the pump and the Reservoir. (See *Figure 9c.*)

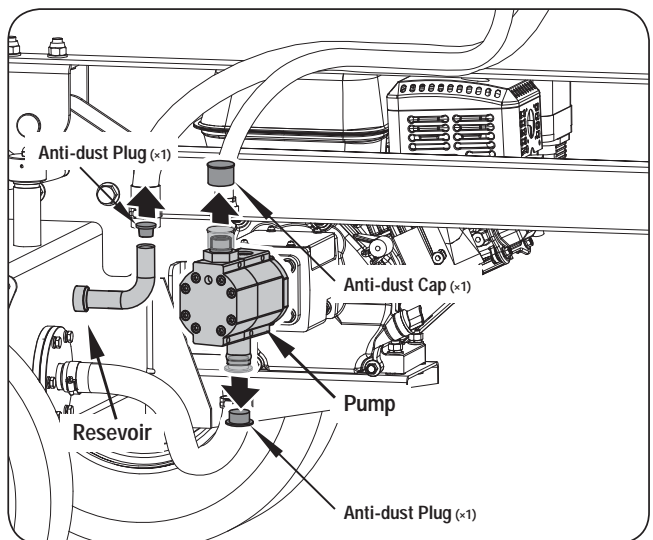

Figure 9c

- Remove the anti-dust plugs from the high pressure supply hose, suction hose and hydraulic return hose. (See *Figure 9d*.)

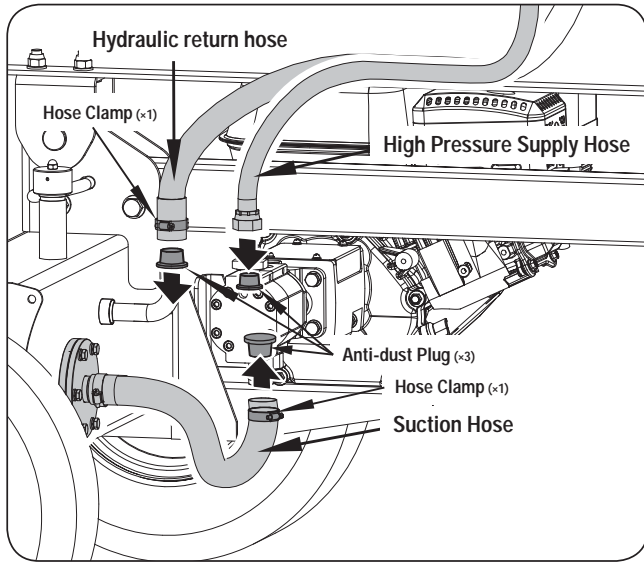

Figure 9d

- Suction Hose coming from the bottom of reservoir, Loosen the hose clamp on the end of this hose, then connect the hose to the fitting on the bottom of the pump. Tighten the hose clamp. (See *Figure 9e*.)
- Loosen the hose clamp on the end of the hydraulic return hose, then connect the hose to the fitting of the reservoir. Tighten the hose clamp.
- High pressure supply hose coming from the bottom of valve, screw the open end of this hose onto the outlet connector on the top of the pump.

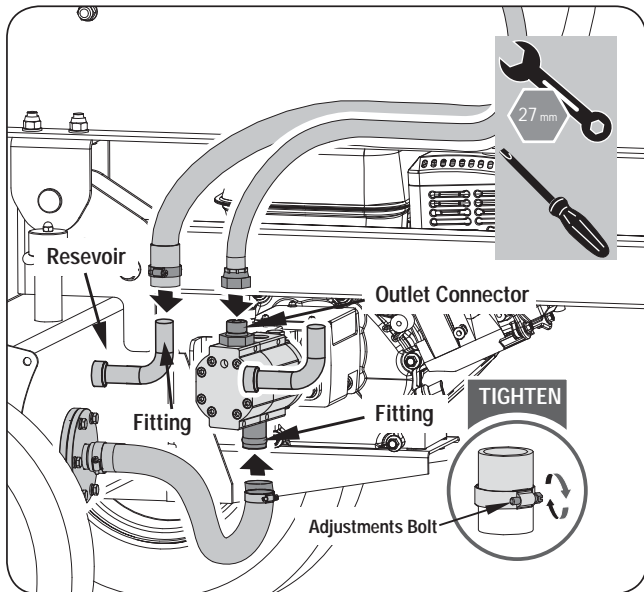

Figure 9e

MANUAL TUBE

- Remove the cap from the manual tube. Align the holes in the manual tube with the holes in the tow bar. Insert and tighten bolts and washers. (See *Figure 10*.)
- Reattach the cap.

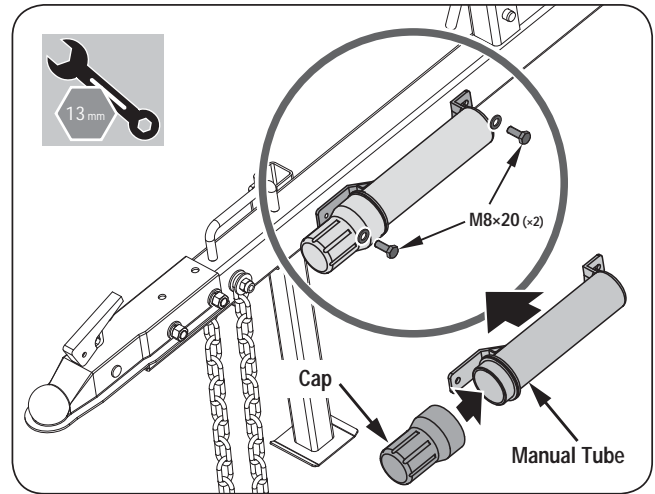



Figure 10

	M8 x 20	x 2	8
---	---------	-----	----------

Log Catcher (Sold Separately)

Align the holes on the log catcher mounts to the holes on the beam. Insert M10x30 bolts, then secure with flat washers and nuts. (See *Figure 11*.)

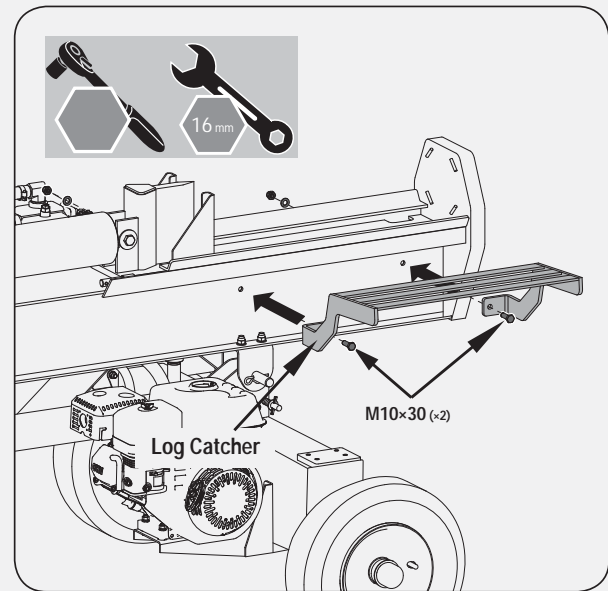



Figure 11

	M10 x 30	x 2	1
---	----------	-----	----------

NOTE

Log Catcher can be installed on either side of the beam.

Log Lift Table Attachment (Sold Separately)

Preparation

1. Remove the bolt, washers and nut, which connect the wedge with the cylinder. (See **Figure 12a.**) Keep the removed hardware set aside for later use.

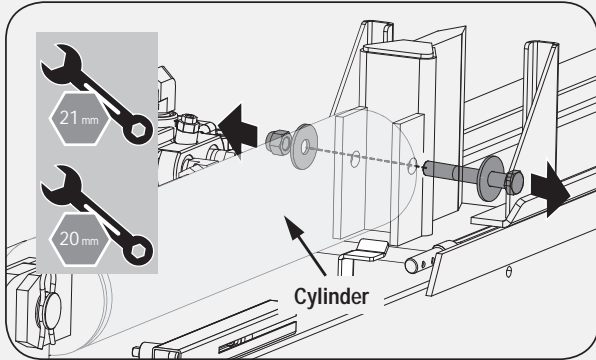

Figure 12a

2. Push the wedge forward until the wedge completely crosses the log stripper. (See **Figure 12b.**)

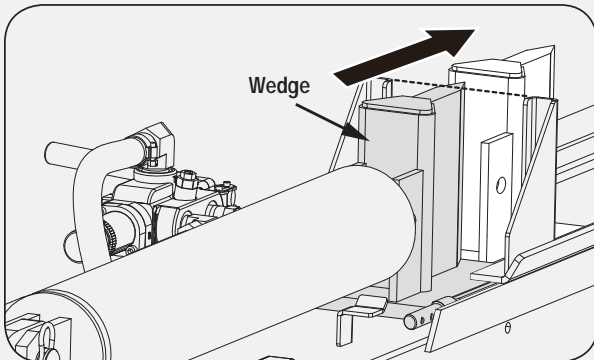

Figure 12b

3. Place a wooden block with a height of about 5.9" under the cylinder, make ensure the stability of the cylinder and wooden block. (See **Figure 12c.**)

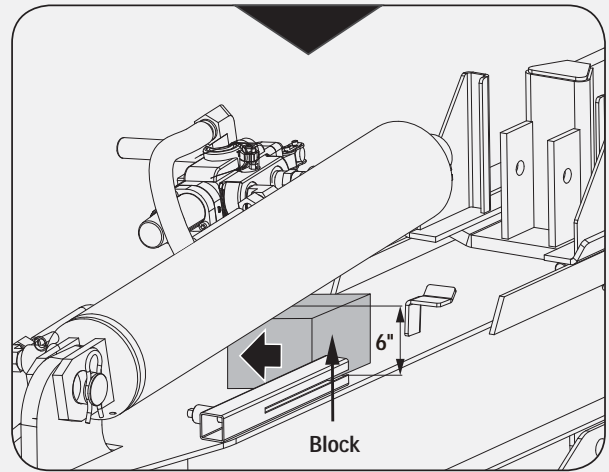
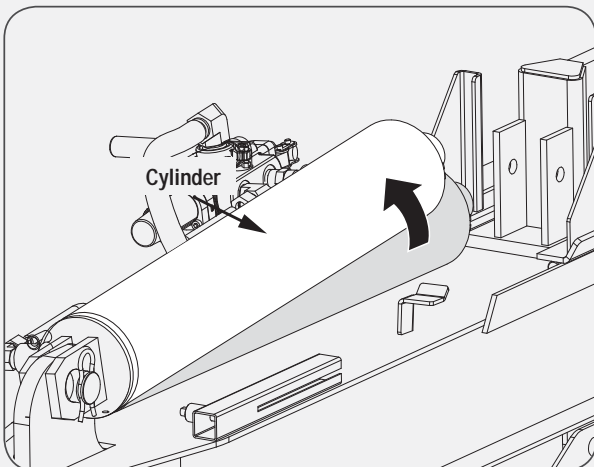

Figure 12c

Ejector Rod Assembly

1. Let the ejector rod go through the fixed guide rail. Align the holes in the front end of the ejector rod with the holes in the wedge side-shaft. (See **Figure 13, illustration 1.**)
2. Fasten the ejector rod with the wedge side-shaft. (See **Figure 13, illustration 2.**)

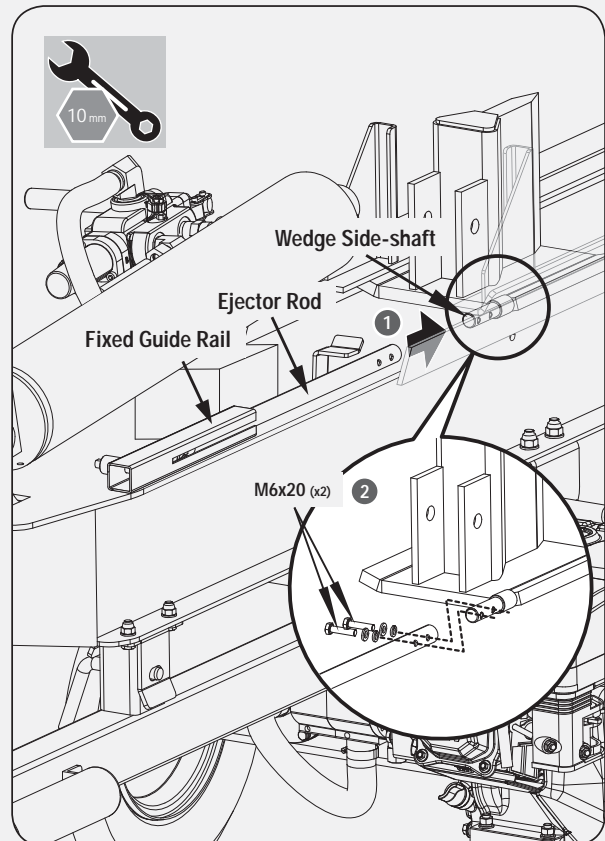

Figure 13



M6 x 20

x 2

1

Cable Fixing Plate and Cable Assembly

1. Install the cable fixing plate, paying attention to keeping the fixing plate hole in line with the center of the side spring pin. (See **Figure 14a.**)

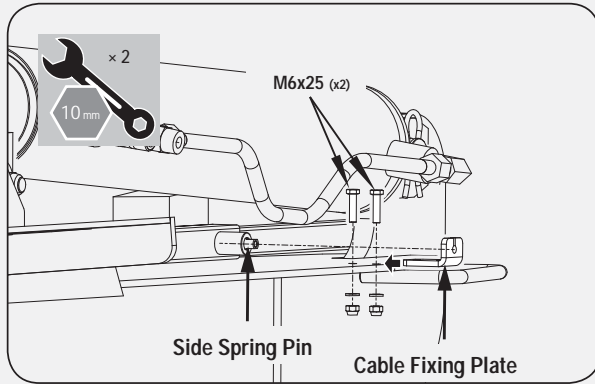

Figure 14a



2. Screw the straight end of the cable into the side spring pin hole. (See **Figure 14b, illustration 1.**) Pass the cable between the lower two adjusting nuts through the middle hole of the cable fixing plate. (See **Figure 14b, illustration 2.**) By adjusting the three adjusting nuts, make sure the cable between the side spring pin and the cable fixing plate is just straightened. (See **Figure 14b, illustration 3.**)

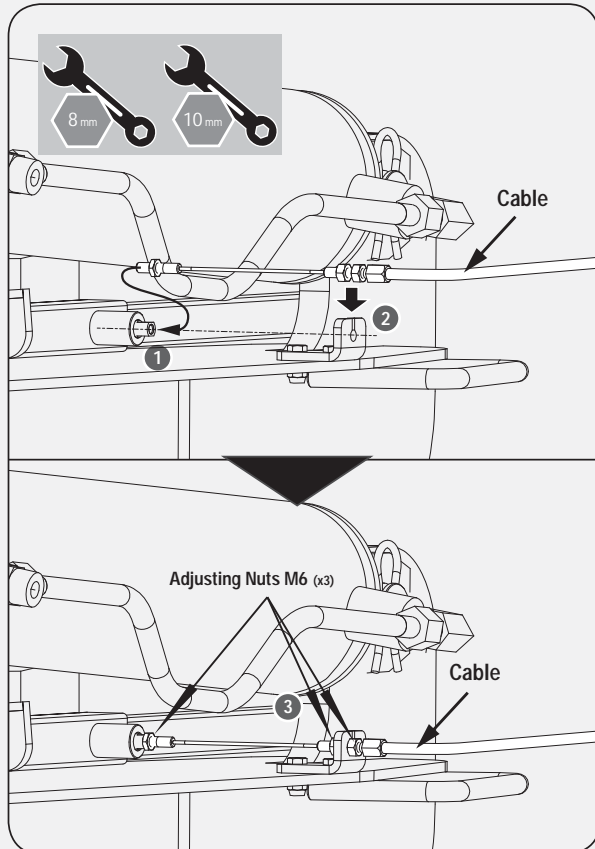

Figure 14b

Handle and Cable Assembly

1. Disassemble the original long control lever (See **Figure 15, illustration 1.**), assemble the shorter log lift table control lever instead with the same hardware parts (See **Figure 15, illustration 2.**)

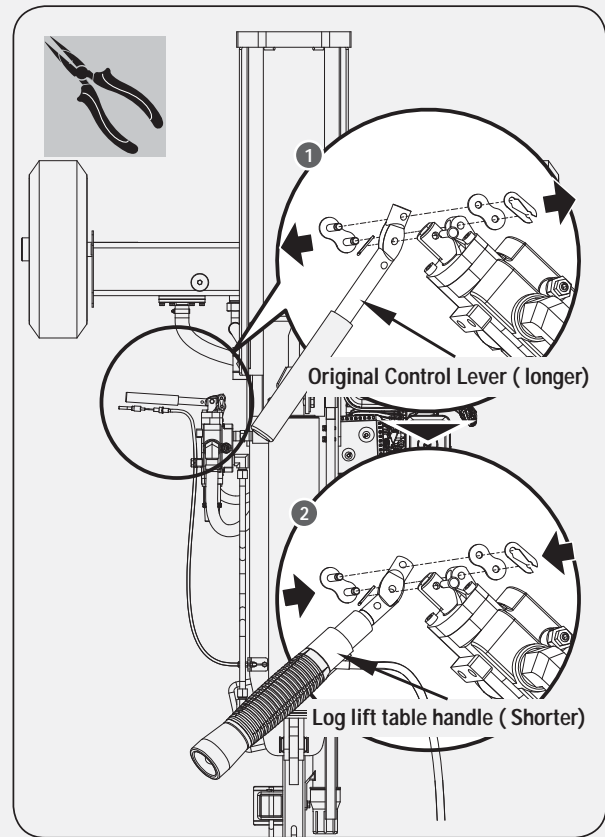

Figure 15

Cable Holder and Cable Assembly

1. Secure the cable onto the bottom of the beam via cable holder. (See **Figure 16.**)

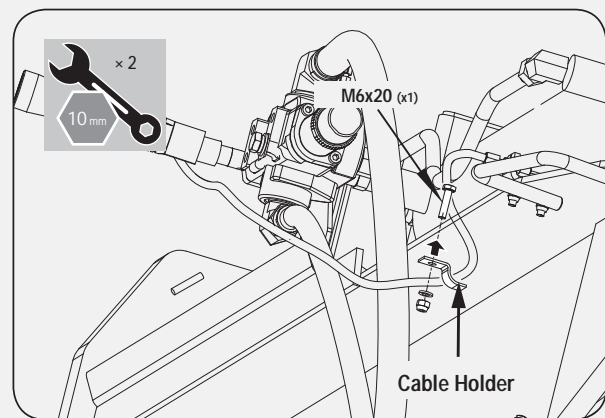
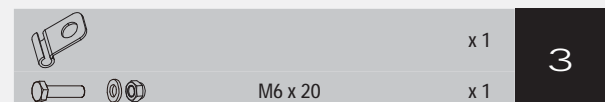

Figure 16



Slide-rail Assembly

1. Pull out the side spring pin and insert the slide-rail through the fixed guide rail until the two bolt holes on the slide-rail are fully exposed. (See *Figure 17a.*)

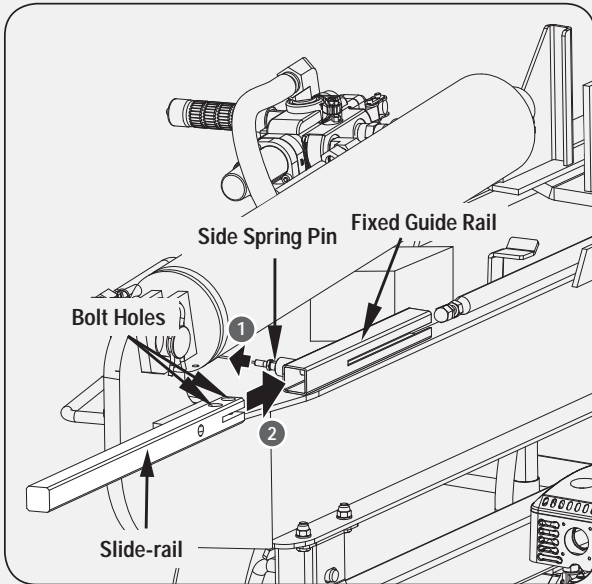

Figure 17a

2. Insert the bending plate into the U-shaped narrow slot of the slide-rail, align the two holes on the bending plate with the two holes on the slide-rail, and then tighten them with M8x16 bolts. (See *Figure 17b.*)

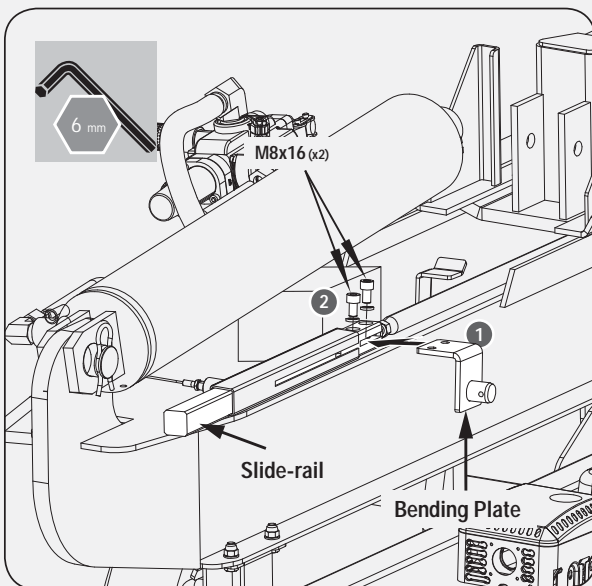



Figure 17b

 M8 x 16 × 2 **4**

Connect wedge and cylinder

1. Remove the wooden block under the cylinder. (See *Figure 18a.*)

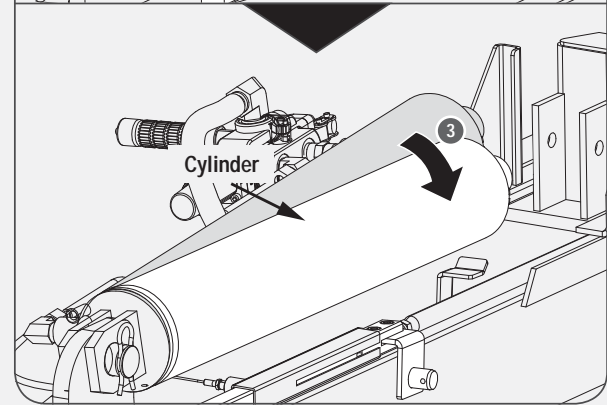
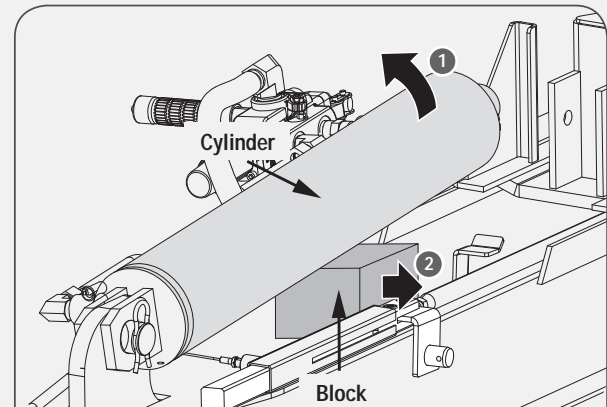

Figure 18a

2. Pull the wedge back. (See *Figure 18b.*)

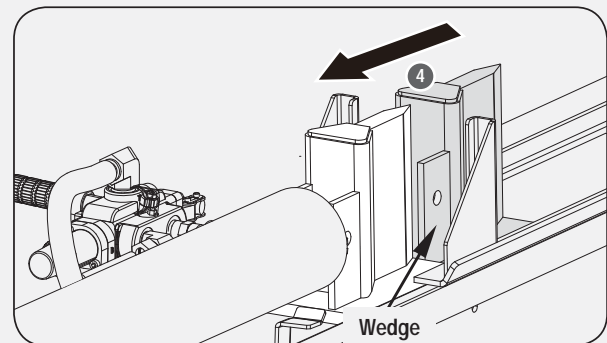

Figure 18b

3. Assemble the wedge and cylinder. (See *Figure 18c.*)

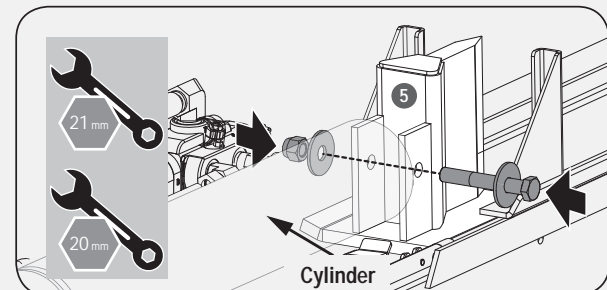

Figure 18c

Connecting Plate Assembly

1. Assemble the connecting plate onto the tank, taking care to ensure the correct bending direction of the plate. (See *Figure 19*.)

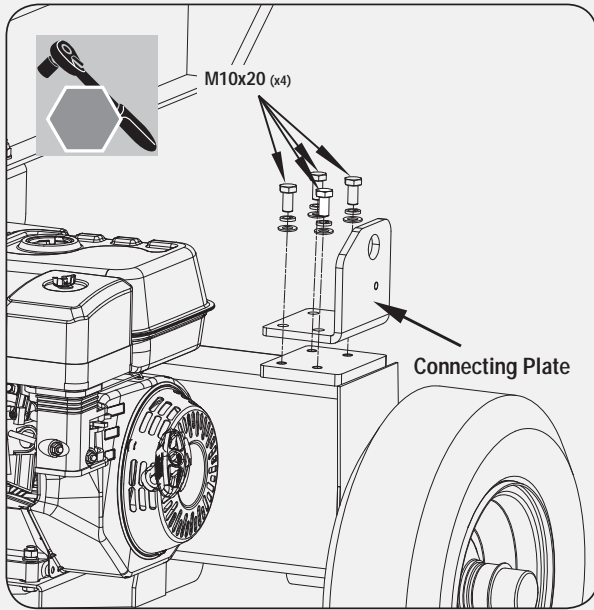

Figure 19

	M10 x 20	x 4	5
--	----------	-----	----------

Main Table & Side Table Assembly

1. Assemble the side table and the main table together to ensure that the hole positions at the connection are aligned. (See *Figure 20a, illustration 1*.)

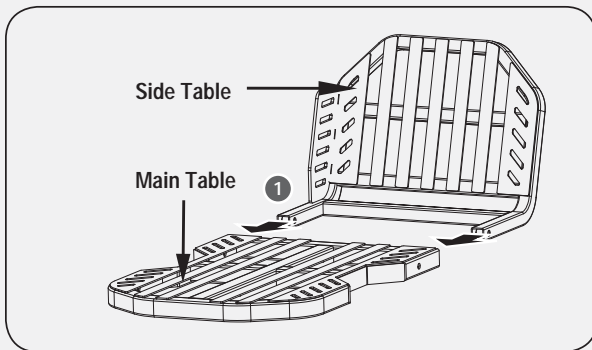

Figure 20a

2. Use a D type pin to insert the right connection hole between the main table and the side table. (See *Figure 20b, illustration 2*.)
3. Align the front hole of the left support leg with the left connecting hole between the main table and the side table, and fix them with a D type pin. At the same time, align the rear hole of the left leg with the left hole at the bottom of the main table and then fasten with M10x70 long bolts, washers and nuts. (See *Figure 20b, illustration 3*.)

4. Assemble the right support leg with the main table. Tighten with bolts, washers and nuts. (See *Figure 20b, illustration 4*.)

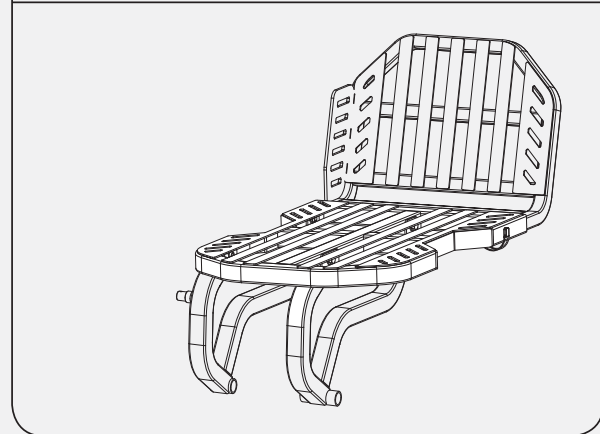
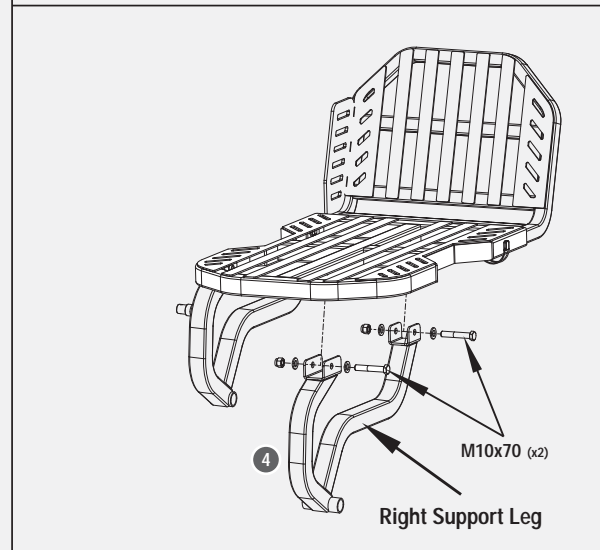
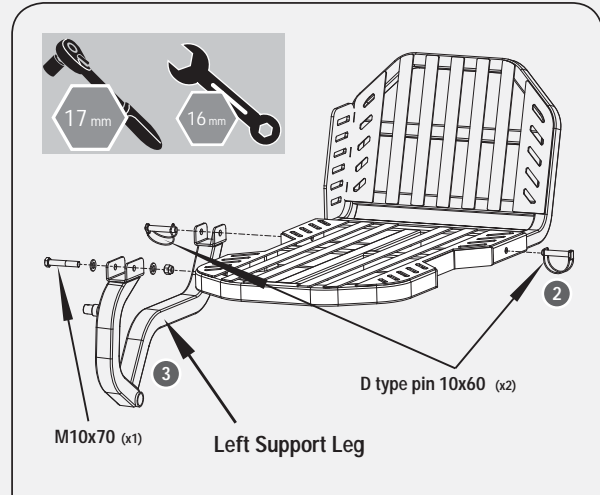

Figure 20b

	M10 x 70	x 3	6
	10 x 60	x 2	

Log Lift Table Attachment Assembly

1. Remove the long bushing and short bushing from the rotating shaft before assembly. (See **Figure 21a**.)

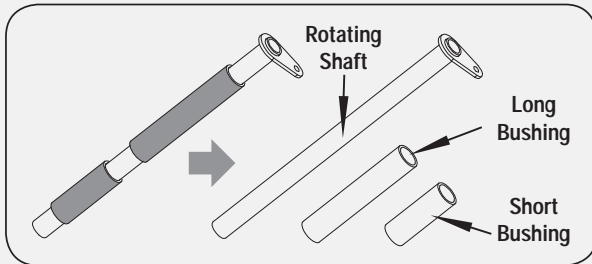

Figure 21a

2. Pass the rotating shaft through the connecting plate, right support leg, long bushing, left support leg, and short bushing in sequence, and finally, wrap it outside the beam pivot pin, then fix it on the connecting plate with M8x20 bolts and washers. (See **Figure 21b**.)

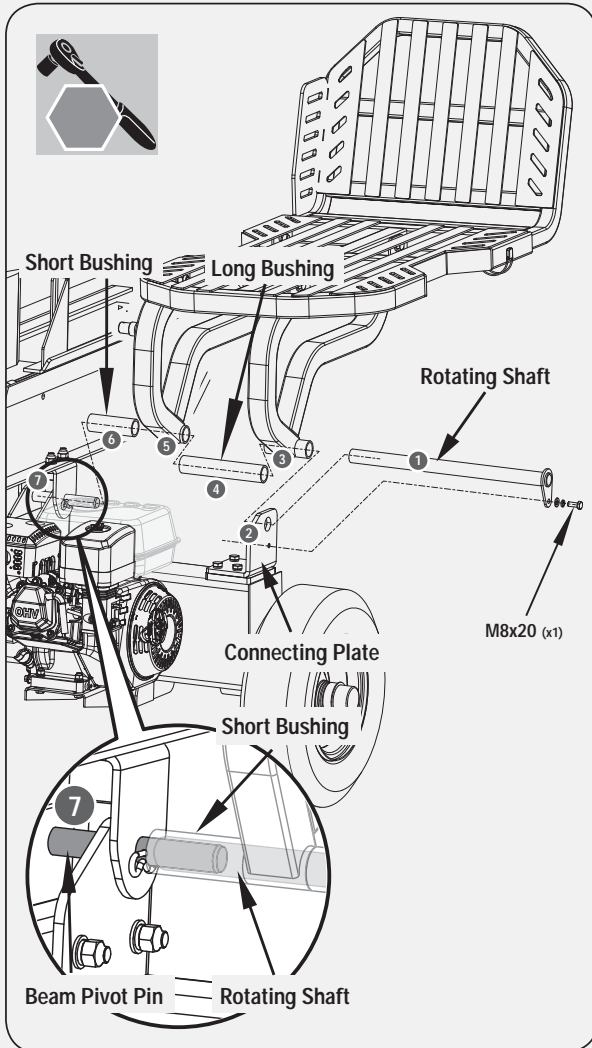

Figure 21b

	M8 x 20	x 1	7
--	---------	-----	----------

Swing Arm Assembly

1. The front hole of the swing arm is fixed to the short shaft on the side of the left leg with bushing, washer and cotter pin. and the rear hole of the swing arm is fixed on the short shaft on the inside of the bending plate. The inner side is fixed with a bushing, a washer and a cotter pin. (See **Figure 22**.)

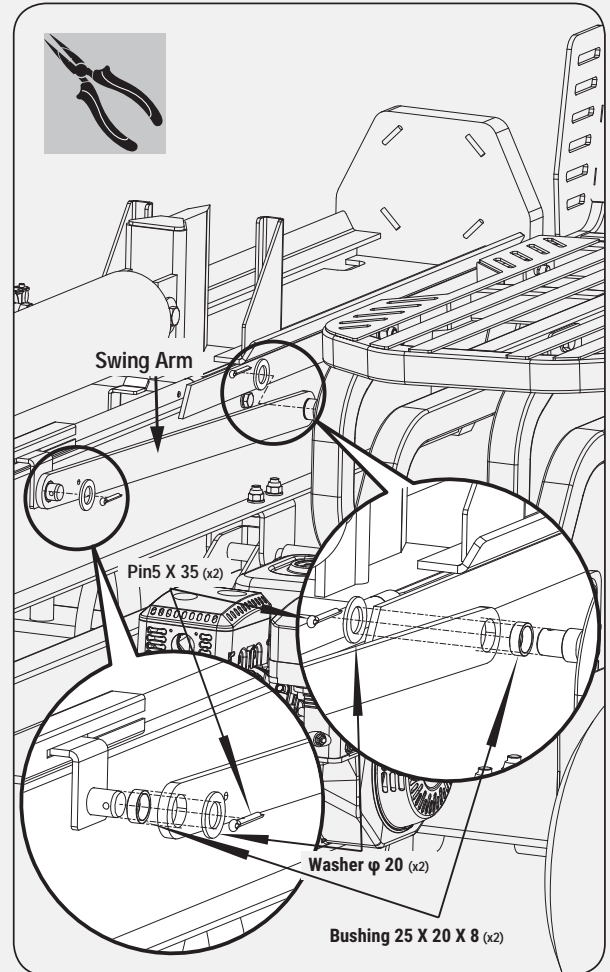

Figure 22

	25 x 20 x 8	x 2	8
	φ 20	x 2	
	5 x 35	x 2	

Log Lift Table Attachment Height Adjustment

1. Loosen the lock nut, adjust the table angle adjustment bolt backward to increase the length of the ejector rod, and the table tilts upward; On the contrary, adjust the table angle adjustment bolt forward to shorten the length of the ejector rod, and the table will tilt down. When the height of the table and beam is aligned, lock the nut tightly. (See *Figure 23.*)

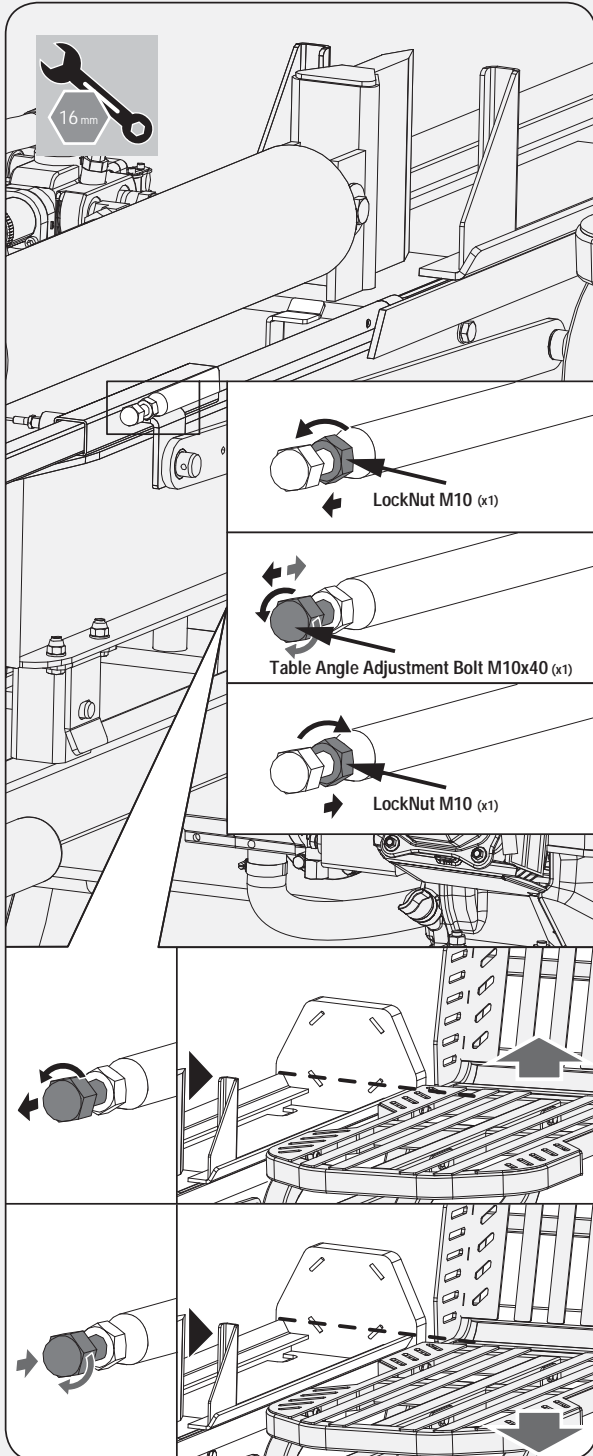
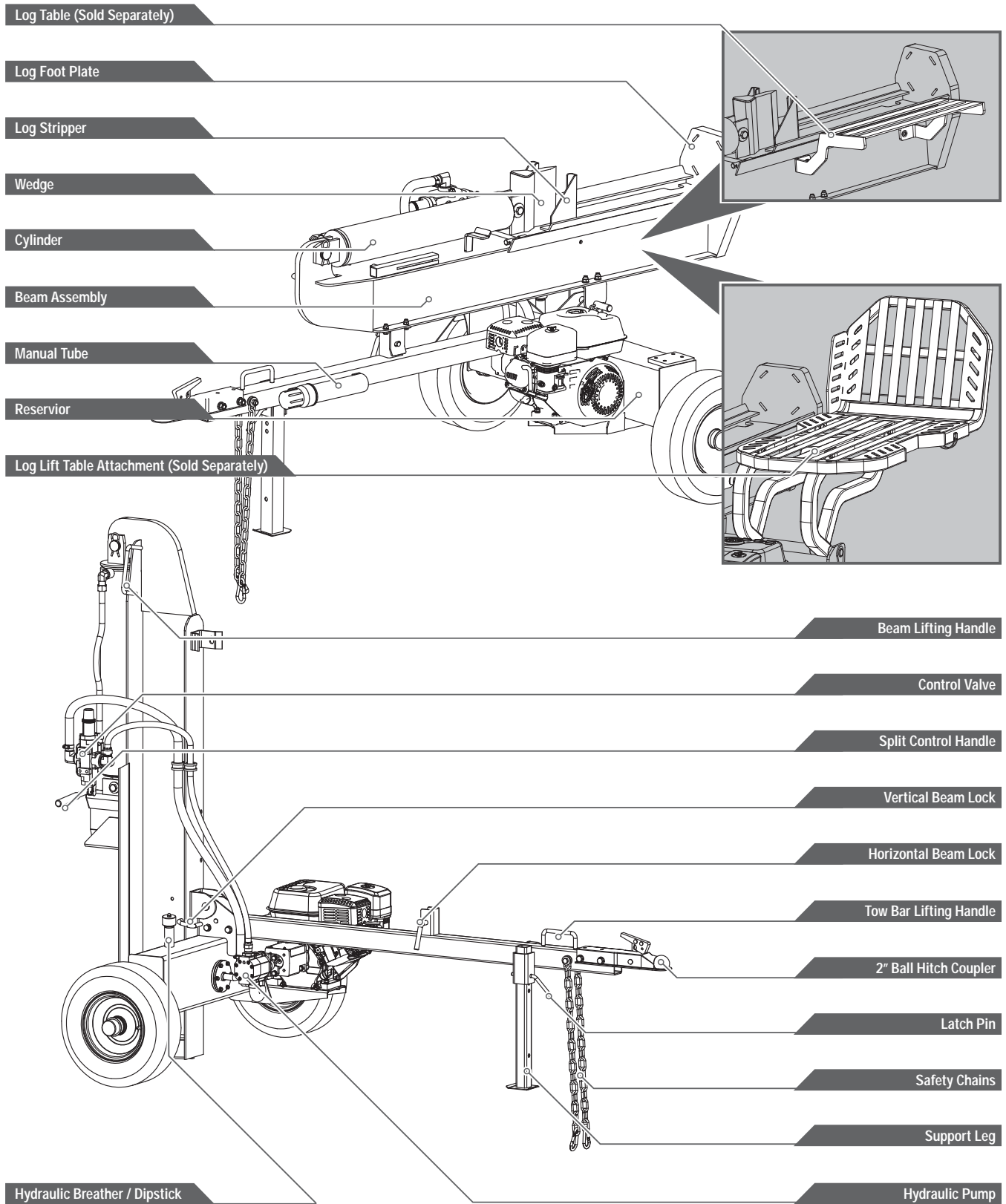
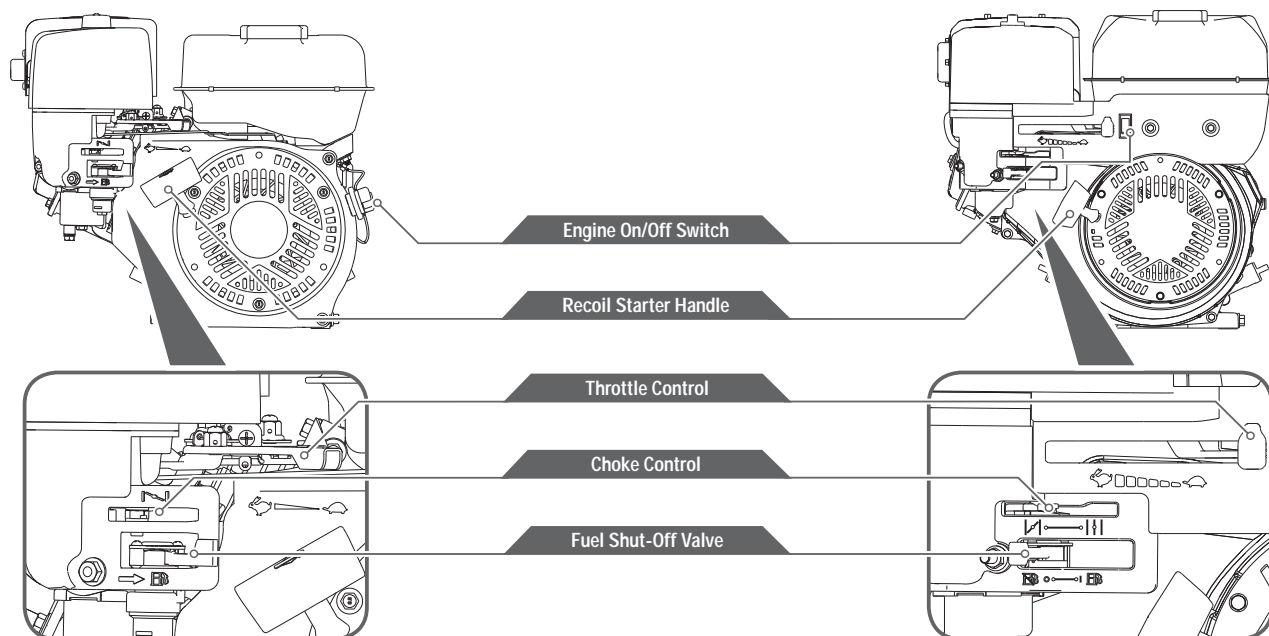

Figure 23

KNOW YOUR MACHINE

FEATURES AND CONTROLS





SPLIT CONTROL HANDLE

- » The control handle is used to move the wedge up and down to split logs. The control handle has three positions: Forward, Neutral, and Reverse. See the “operation” section for instruction.

MANUAL TUBE

- » Keep manuals safely in the tube.

BEAM LOCK BRACKET

- » The beam lock bracket is used to secure the beam in the horizontal position.

LIFTING HANDLE

- » The lifting handle is included for easy transition from horizontal to vertical.

2" BALL HITCH COUPLER

- » The coupler hitch is at the end of the tow bar and attaches to a tow ball for transportation purposes.

LOG STRIPPER

- » The log stripper is designed to remove any partially split wood from the wedge. This may occur while splitting large diameter wood or freshly cut wood.

BEAM ASSEMBLY

- » The U-beam structural design is significantly stronger than a typical I-beam design.

LOG TABLE (Sold Separately)

- » A log table/platform can be mounted on the log cradle directly.

LOG LIFT TABLE ATTACHMENT (Sold Separately)

- » The log lift table attachment can be mounted on the beam. Easily lift the log from the ground to a position flush with the beam.

ENGINE ON/OFF SWITCH

- » The engine switch has two positions. OFF - engine will not start or run. ON - engine will start and run.

RECOIL STARTER HANDLE

- » The handle is used to start the engine.

FUEL SHUT-OFF VALVE

- » The fuel shut – off has two position. CLOSED (🔒) - use this position to service, transport, or store the unit.
- » OPEN (🔓) - use this position to run the unit.

CHOKE CONTROL

- » The choke control is used to choke the carburetor and assist in starting the engine. The choke control slides between the CHOKE CLOSED | and CHOKE OPEN | positions.

THROTTLE CONTROL

- » The throttle control regulates the speed of the engine and will shut off the engine when it is moved to the STOP position. The throttle control moves between FAST 🐇, SLOW 🐢, and STOP positions.

OPERATION

! DANGER

Many accidents occur when more than one person operates the log splitter. If a helper is assisting in loading logs to be split, never operate the controls until the helper is clear of the area.

! WARNING

The engine is shipped without oil. Do not start the engine before adding oil.

ADD OIL TO ENGINE

1. Make sure the log splitter is on a flat, level surface.
2. Remove the oil fill cap/dipstick to add oil.
3. Using a funnel, add oil up to the FULL mark on the dipstick. (See engine manual for oil capacity, oil recommendation, and location of fill cap.)

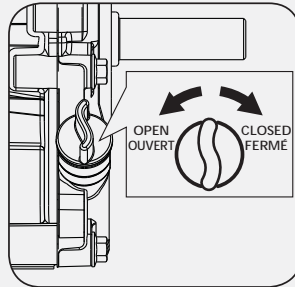

! CAUTION

DO NOT OVERFILL. Check engine oil level daily and add as needed.

ADD GASOLINE TO ENGINE

! DANGER

Gasoline is highly flammable and explosive. You can be burned or seriously injured when handling fuel. Use extreme care when handling gasoline.

! DANGER

Fill the fuel tank outdoors, never indoors. Gasoline vapors can ignite if they collect inside an enclosure. Explosion can result.

1. The engine must be off and allowed to cool at least two minutes before adding fuel.
2. Remove the fuel filler cap and fill the tank. (See engine manual for fuel capacity, fuel recommendation, and location of fuel cap.)

! WARNING

IMPORTANT: DO NOT OVERFILL! This equipment and/or its engine may include evaporative emissions control system components, required to meet EPA and/or CARB regulations, that will only function properly when the fuel tank has been filled to the recommended level. Overfilling may cause permanent damage to evaporative emissions control system components. Filling to the recommended level ensures a vapor gap required to allow for fuel expansion.

! WARNING

IMPORTANT: DO NOT OVERFILL! Pay close attention while filling the fuel tank to ensure that the recommended fuel level inside the tank is not exceeded. Use a portable gasoline container with an appropriately sized dispensing spout when filling the tank. Do not use a funnel or other device that obstructs the view of the tank filling process.

3. Reinstall the fuel cap and tighten. Always clean up spilled fuel.

ADD HYDRAULIC OIL TO OIL TANK

(FOR H6028FB / H6028BR / H6033FB / H6033BR / H6038FB / H6038BR ONLY)

1. Make sure the log splitter is on a flat, level surface.
2. Remove the oil dipstick from the oil tank.

! WARNING

Never remove the hydraulic oil dipstick when the engine is running or hot. Hot oil can escape causing severe burns. Allow the log splitter to cool completely before removing the hydraulic oil dipstick.

3. The recommended hydraulic oil type:
10W AW32
ASLE H-150
ISO 32

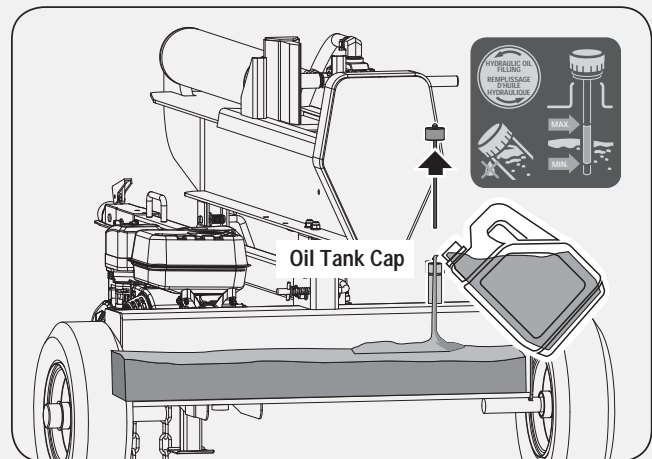

Figure 24

4. Make sure the hydraulic oil level reaches the upper line of the dipstick.

! CAUTION

Completely install the dipstick when checking oil level.

5. Start the engine and use the control valve handle to extend and retract the wedge five times to remove air from the high pressure lines.
6. With the wedge retracted and engine off, check the oil level again. Fill if necessary.
7. Cycle the cylinder again until it has a constant speed. This indicates that all air has been expelled.

STARTING ENGINE

1. Make sure the control lever is in the neutral position.

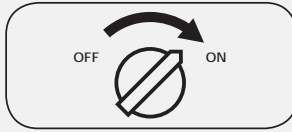

2. Move the engine switch to the ON position.

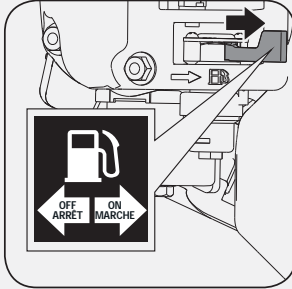

3. Open the fuel shut-off valve.

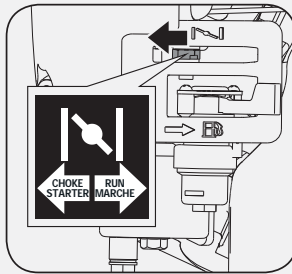

4. Move the choke lever to the CLOSED position.

» If the engine is hot, closing the choke is not necessary.

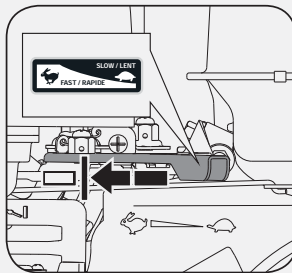

5. Move the throttle lever slightly to the FAST speed.

6. Pull the recoil starter until engine compression has become difficult to pull. Let the recoil return to the home position, then pull quickly to start the engine. Repeat steps as needed. Fully open the choke and set the throttle to the FAST position, before operating the unit.

! WARNING Rapid retraction of the starter cord (kickback) will pull your hand and arm toward the engine faster than you can let go. Broken bones, fractures, bruises, or sprains could result.

STOP ENGINE

Return the cylinder to fully retracted position or home position. Move the Throttle lever to SLOW (←). Move the engine switch to OFF. Close the fuel shut-off valve (⊘).

! WARNING Sudden stopping at a high speed under a heavy load is not recommended. Engine damage may result.

SPLIT CONTROL HANDLE

Forward position – Move the lever in this direction to extend the cylinder toward the spinner foot plate. Keep pressure on the lever until the log splits. The lever does not lock in this position. Release as soon as the log is split or the cylinder is fully extended. (See *Figure 25a* and *Figure 25b*.)

! WARNING Never operate through the relief valve for more than 5 seconds.

» The splitter wedge is designed to reach the full extension before contacting the foot plate.

» To extend the life of the hydraulic cylinder, avoid “bottoming out” the wedge plate to the foot piece. To conform with industry safety recommendations, the wedge stops 1.5 inches from the end of the stroke.

! DANGER Cracks in logs can close quickly and pinch fingers. Keep fingers away from any cracks that open in partially split logs.

Neutral position – In this position the cylinder does not move even though the engine is running.

Reverse position – Move the lever in this position to retract the cylinder. Push the lever fully in this direction to lock it return mode. The lever will automatically return to the neutral position once the cylinder fully retracts.

! DANGER Keep hands and fingers away from the splitter wedge and log stripper during cylinder retraction.

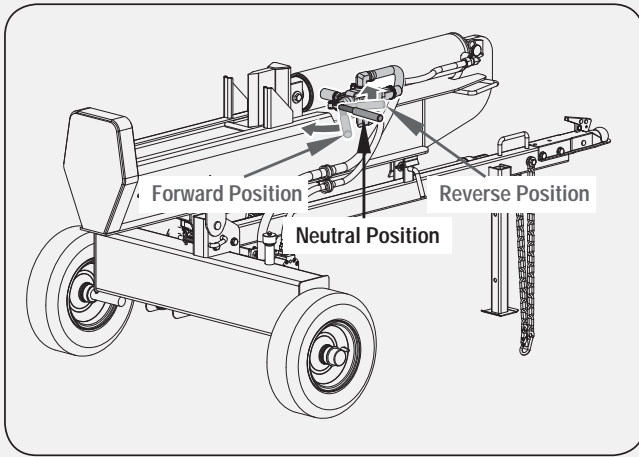

Figure 25a

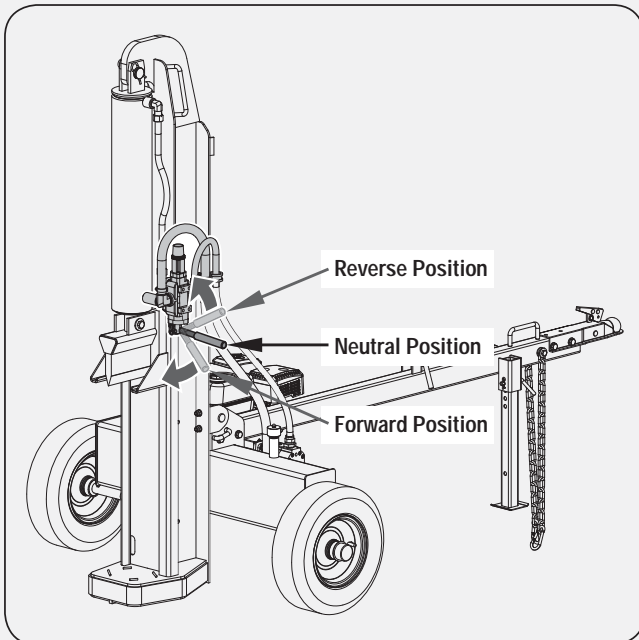

Figure 25b

STUCK LOG PROCEDURE

If a log does not split completely and becomes stuck on the wedge, never attempt to remove it by modifying the splitter or adding attachments to the splitter.

Move the control lever to the Reverse position and allow the cylinder to retract until the stuck log contacts the stripper plates. Continue to retract the cylinder until the log is dislodged from the wedge.



DANGER

Do not use the unit if the stripper plates are bent or damaged. Bent or damaged stripper plates must be repaired or replaced before use.

CONVERSION BETWEEN HORIZONTAL SPLITTING POSITION AND VERTICAL SPLITTING POSITION

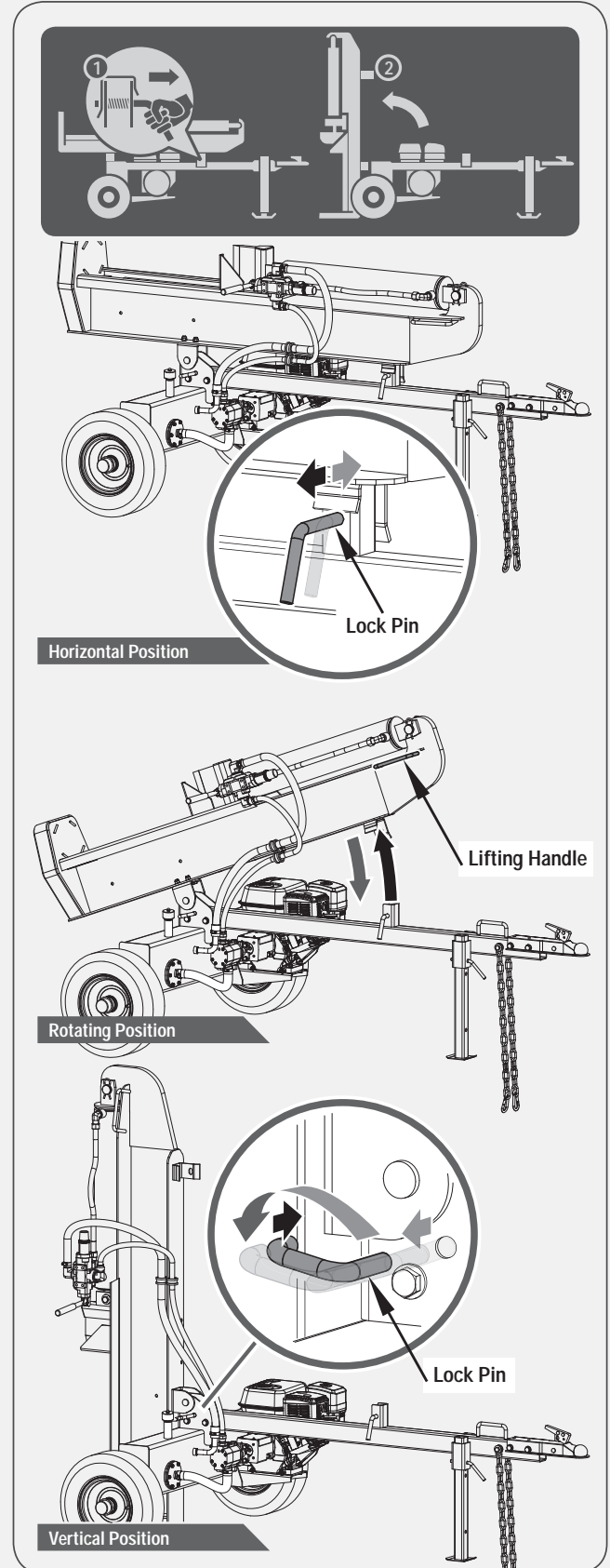

Figure 26

Log Lift Table Attachment Operation (Sold Separately)

1. When the log lift table attachment is flush with the beam, pull the control lever of the control valve outward while pushing it forward. then the wedge moves forward, and at the same time, the log lift table attachment will go downward. (See *Figure 27a.*)

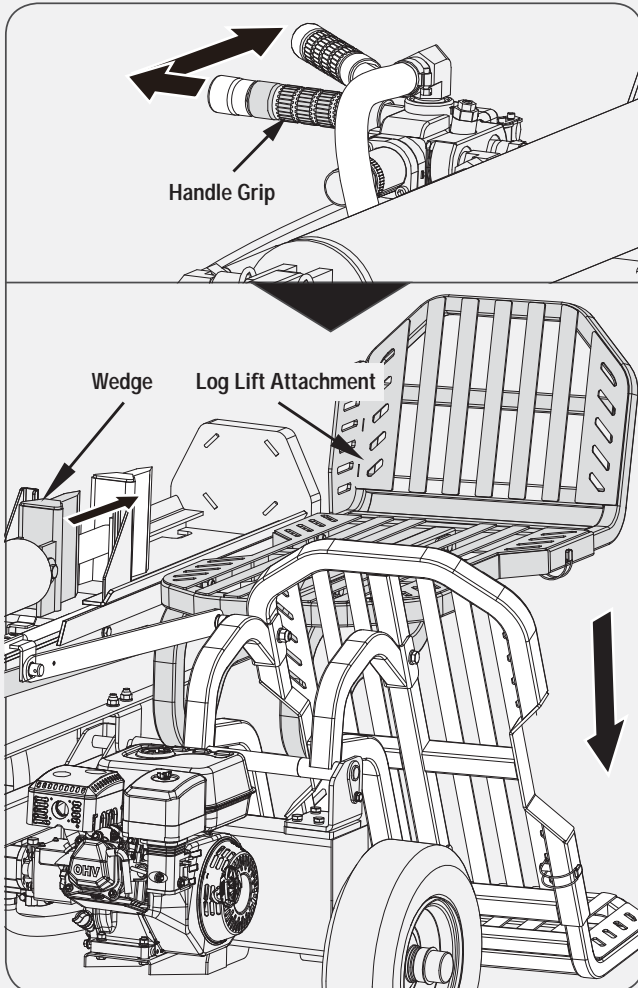
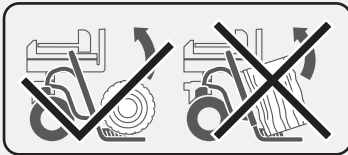

Figure 27a

2. Make sure wedge and log lift table stop moving, load the log on the table.



3. Give the control lever a backward thrust, wait until the wedge starts to move, release the control lever, and then the log lift table attachment starts to rise. (See *Figure 27b.*)

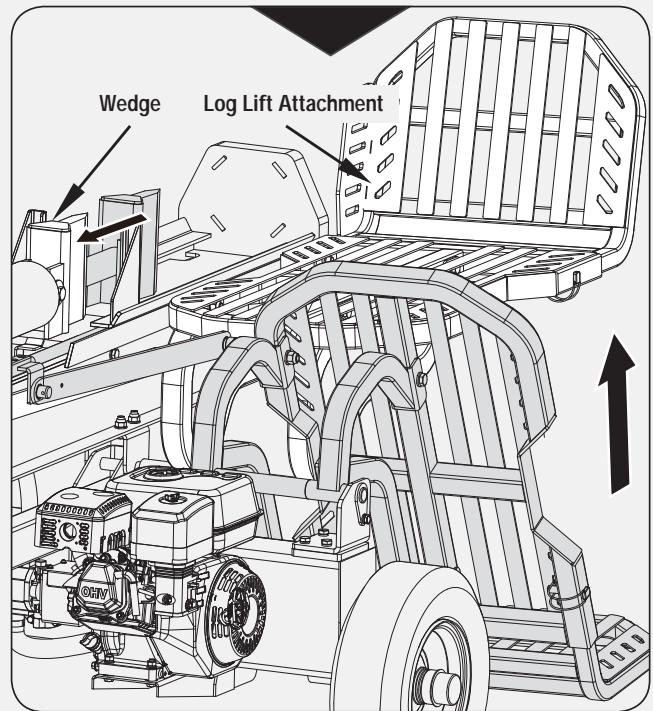
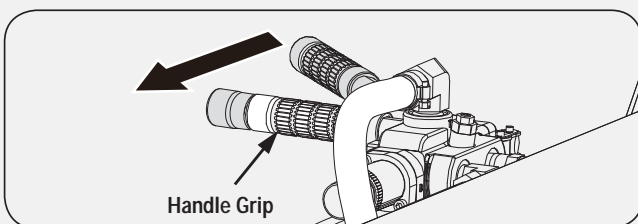

Figure 27b

4. Move the log from log table to the beam.
5. Push the control lever forward, the wedge will go forward to split the log. Give the control lever a backward thrust, then release the lever, the wedge will go back to the start position.

⚠ WARNING When the wedge is extended and not fully return back, it is prohibited to pull the control lever outwards, otherwise the lift log table attachment may suddenly drop, causing unexpected risks such as falling logo and so on. (See *Figure 28.*)

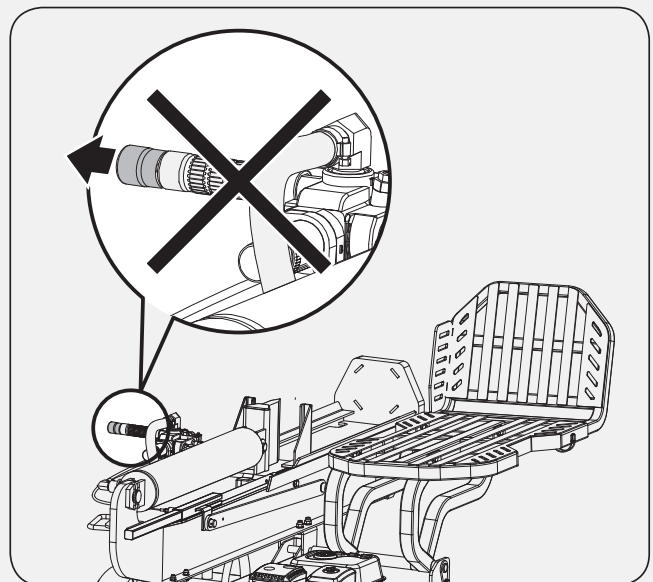

Figure 28

6. Repeat the operate from Step 1-5 to complete the log lifting and splitting again.

TRANSPORTING

MOVING BY HANDS

! DANGER *The log splitter is heavy. It can crush and cause serious injury if it rolls out of control or tips over.*

Follow the instructions below for safely moving the log splitter.

1. Make sure the log splitter is locked in the horizontal position with latch rod before moving.

! DANGER *Make sure the log splitter engine is off. Never move the log splitter with its engine running.*

2. Turn the fuel shut-off valve to the OFF position. This prevents carburetor flooding and reduces the chance of fuel leakage. Refer to the engine manual for fuel valve location.
3. Lock the support leg in the DOWN position before you move the log splitter.
4. Move the log splitter by hand to desired work site.

! WARNING *Do not move the log splitter up or down hills by hand.*

! DANGER *Never allow anyone to sit or ride on the log splitter.*

! WARNING *Never transport cargo or wood on the log splitter.*

TOWING BY VEHICLE

1. Turn the fuel shut-off valve off. This prevents fuel from flooding the engine.

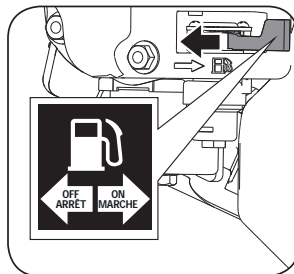

2. Check the tires to ensure they are fully inflated to 30 PSI for proper functionality.

! WARNING *Do not overinflate tires. Serious injury can occur if tire explodes.*

! WARNING *When seating a bead after repair, do not exceed 30 PSI. Pressures higher than 30 PSI can cause the tire and wheel to rupture and explode.*

3. Make sure hitch is in good working order.
4. Check safety chains. Two safety chains must be used while towing. Cross safety chains under the coupler, allowing only enough slack for vehicle turns.
5. Pull out the lock lever and put the support leg in the UP position, then release the lever and make sure the leg is secured.

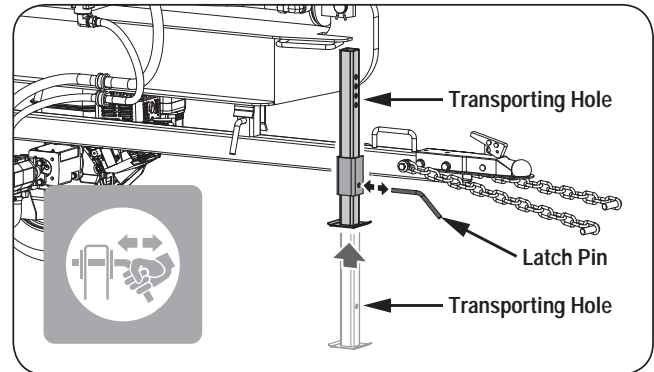

Figure 29

6. Tow the log splitter carefully to desired work site.

! CAUTION *Be aware of the added length of the splitter.*

! DANGER *Never tow this log splitter over 45 mph. Faster speeds may result in loss of control.*

! DANGER *Drive slowly and take extra caution when traveling over rough terrain.*

! DANGER *If towing on a public road, make sure to comply with all local, state, and federal towing requirements. It is the sole responsibility of the purchaser to obtain licensing, trailer lights, safety chains, or signage as needed to comply.*

! WARNING *Turn off the towing vehicle before leaving the splitter unattended.*

7. Lock the support leg in the DOWN position and disconnect from vehicle.

! DANGER *Never operate the log splitter while it is attached to the vehicle.*

MAINTENANCE

Inspect and maintain the log splitter before each use. If the log splitter has been used previously, it must be inspected and maintained before each subsequent use.

Always shut off the engine and relieve system pressure before inspecting, cleaning, adjusting, or repairing the splitter. Relieve system pressure by moving the split control lever back and forth several times.

Remove debris from the engine, muffler, and moving parts. Debris on a hot engine can be a fire hazard. Clean debris and chaff from the engine cylinder head, cylinder head fins, blower housing rotating screen, and muffler areas.

! DANGER Avoid contact with hot muffler.

! CAUTION Debris on moving parts can cause excess wear. Clear debris from the slide beam, wedge, and end plate.

OIL DRAINING

Use a drain pan to aid in the removal of all used oil and particles.

Remove oil drain plug to drain oil from the hydraulic transmission system. Examine oil for metal chips as a precaution to future problems.

After oil has been completely drained from the machine, reinstall drain plug.

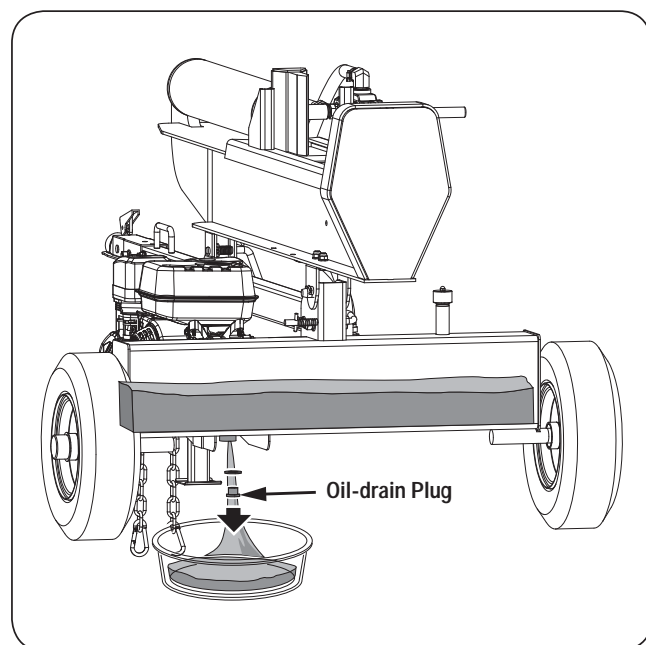

Figure 30

ADD HYDRAULIC OIL TO OIL TANK

1. Make sure the log splitter is on a flat, level surface.
2. Remove the oil dipstick from the oil tank.

! WARNING Never remove the hydraulic oil dipstick when the engine is running or hot. Hot oil can escape causing severe burns. Allow the log splitter to cool completely before removing the hydraulic oil dipstick.

3. The recommended hydraulic oil type:
10W AW32
ASLE H-150
ISO 32

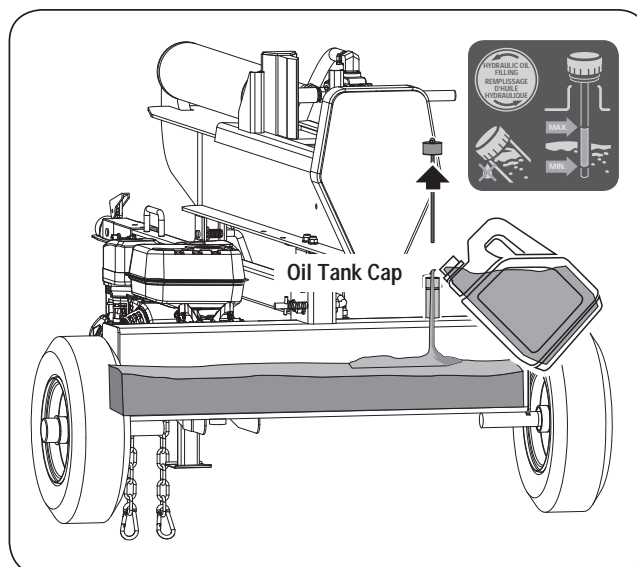

Figure 31

4. Make sure the hydraulic oil level reaches the upper line of the dipstick.

! CAUTION Completely install the dipstick when checking oil level.

5. Start the engine and use the control valve handle to extend and retract the wedge five times to remove air from the high pressure lines.
6. With the wedge retracted and engine off, check the oil level again. Fill if necessary.
7. Cycle the cylinder again until it has a constant speed. This indicates that all air has been expelled.

STORAGE

Follow the instructions below for storing your log splitter between uses.

1. Retract the wedge completely to keep the rod protected from corrosion.
2. Allow the machine to cool 5 minutes before storing.
3. Clear the debris from the beam, wedge, and end plate. Use a damp cloth to clear exterior surfaces of the engine and log splitter. Use a soft bristle brush to remove excess dirt and oil. Use an air compressor (25 PSI) to clear dirt and small debris. Wipe the beam, wedge, and all metal parts with an oil rag to prevent corrosion.

 **WARNING** *Never spray the engine or log splitter with a pressure washer. Water can contaminate the fuel system and can enter the engine and damage the engine.*

4. Refer to the engine manual for proper engine storage instructions.

 **DANGER** *Gasoline can become stale when stored over 30 days. Stale fuel can cause acid and gum deposits that form in the fuel system or on carburetor parts. For engine fuel that is stored less than 30 days, add a fuel stabilizer to keep the fuel fresh. Turn the fuel valve lever to the off position. If fuel is stored over 30 days, then drain the fuel tank as stated in the engine manual.*

 **DANGER** *Always drain fuel from the tank in an outdoor, well-ventilated area.*

Stay away from sources of heat, flame, or sparks while handling fuel.

Clean up fuel spills immediately.

5. Store the log splitter in a location away from corrosive materials, sources of heat, open flames, sparks, or pilot lights.

 **DANGER** *Never store the log splitter inside where there is a source of heat or an open flame, spark, or pilot light, such as a water heater, space heater, furnace, clothes dryer, or other gas appliance. EVEN IF the log splitter's fuel tank is empty, residual gasoline vapors could ignite.*

Never store the log splitter near fertilizer or any other corrosive material.

6. Store gasoline in a cool, dry place in a UL listed tightly sealed container.

 **DANGER** *Gasoline vapors can ignite if they collect inside an enclosure and explosion can result.*

TROUBLESHOOTING

Problem	Cause	Remedy
Wedge movement is slow or erratic	<ol style="list-style-type: none"> 1. Air in the hydraulic oil system 2. Debris lodged in beam guides 3. Low hydraulic oil 	<ol style="list-style-type: none"> 1. Purge air by extending and retracting the wedge several times until motion is smooth 2. Clear debris from beam 3. Check oil level and add as needed
Oil leak from cylinder	<ol style="list-style-type: none"> 1. Faulty cylinder rod seal 2. Scored or bent cylinder rod 3. Loose hydraulic fitting 4. Faulty combination washer seal on cylinder hydraulic fitting 	<ol style="list-style-type: none"> 1. Contact customer service 2. Contact customer service 3. Tighten hydraulic fitting 4. Contact customer service
Oil leak from hose connection	Loose hose clamp or hydraulic fitting	Tighten hose clamp or hydraulic fitting
Wedge will not extend or retract	<ol style="list-style-type: none"> 1. Faulty control valve 2. Faulty hydraulic pump 3. Low hydraulic oil 	<ol style="list-style-type: none"> 1. Contact customer service 2. Contact customer service 3. Check oil level and add as needed
Wedge does not auto-return	<ol style="list-style-type: none"> 1. Low hydraulic oil 2. Faulty control valve 	<ol style="list-style-type: none"> 1. Check oil level and add as needed 2. Contact customer service
Excessive bouncing while towing	Underinflated	Inflate tires to proper pressure
Control valve handle does not return to neutral when released from forward position	<ol style="list-style-type: none"> 1. Hydraulic oil too cold 2. Hydraulic oil too thick 3. Hydraulic oil contaminated 4. Faulty control valve 	<ol style="list-style-type: none"> 1. Warm up engine 2. Replace hydraulic fluid 3. Replace hydraulic fluid 4. Contact customer service
Engine will not start	<ol style="list-style-type: none"> 1. Engine switch in OFF position 2. Fuel shut-off valve in OFF position 3. Fuel tank empty 4. Spark plug disconnected 5. Faulty spark plug 6. Choke lever in wrong position 7. Faulty engine 	<ol style="list-style-type: none"> 1. Move switch to ON position 2. Move valve to ON position 3. Fill fuel tank with fuel 4. Connect spark plug 5. Replace spark plug 6. Adjust choke lever position 7. Contact customer service

PARTS DIAGRAM

H6028FB / H6028FB0 / H6028BR / H6028BR0

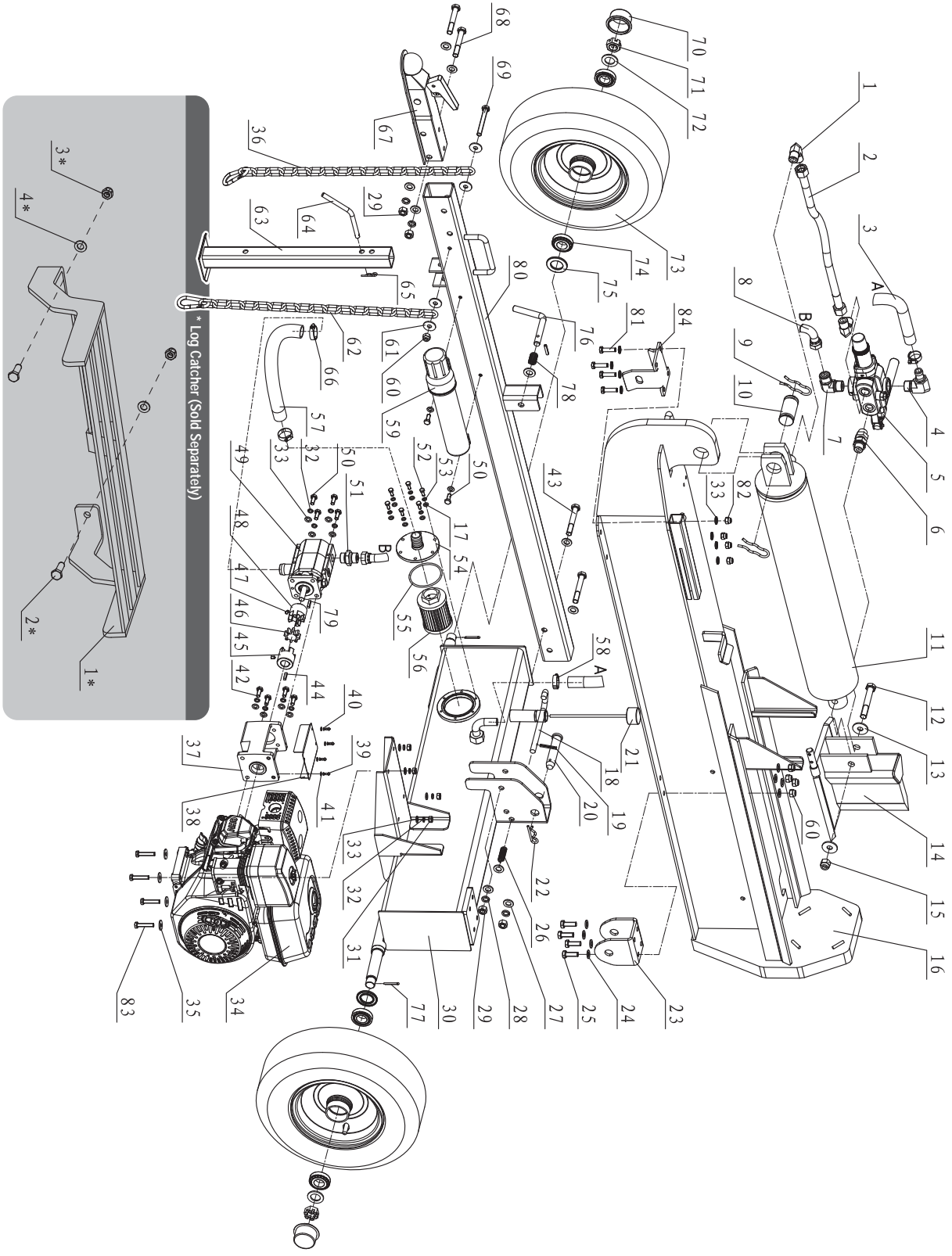

H6033FB / H6033FBO / H6033BR / H6033BRO

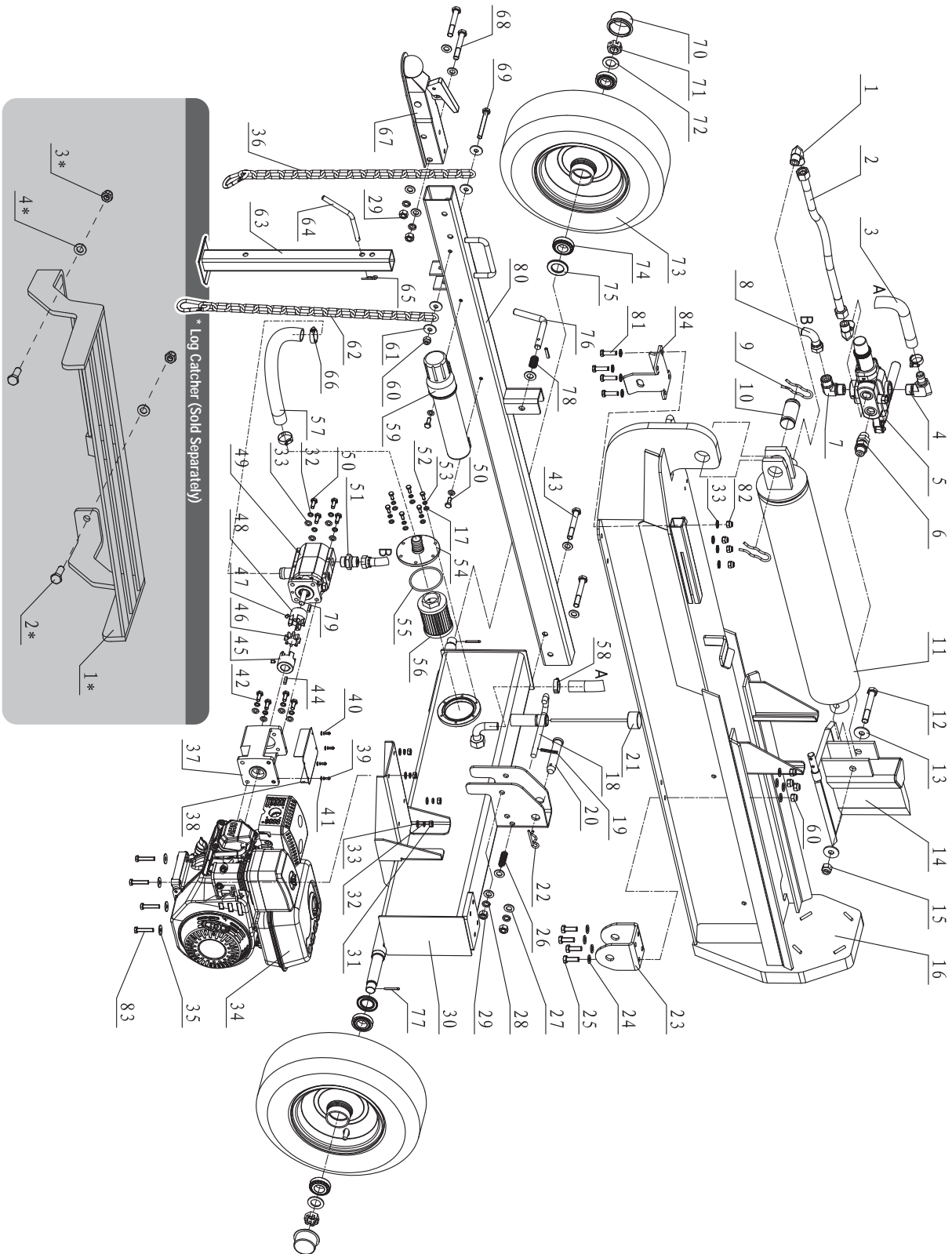

* Log Catcher (Sold Separately)

**H6028FB/H6028FBO/H6028BR/H6028BRO/
H6033FB/H6033FBO/H6033BR/H6033BRO PARTS LIST**

No.	Description	Qty	No.	Description	Qty	No.	Description	Qty
1	Right-Angle Fitting 1/2"	2	37	Pump Bracket	1	70	Dust Cap	2
2	Welded Hose	1	38	Cover of Pump Bracket	1	71	Axle Nut M22	2
3	Low Pressure Return Hose	1	39	Screw M4×8	4	72	Wheel Washer 22	2
4	Right-Angle Fitting 1	1	40	Spring Washer 4	4	73	Tire	2
5	Control Valve	1	41	Washer 4	4	74	Bearing	4
6	Valve Straight Fitting 1/2"	1	42	Bolt M8×25 only for H6028FB/ H6028FBO/H6033FB/H6033FBO	4	75	Anti-Dust Washer	2
7	Right-Angle Fitting 1	1		Bolt 5/16-24 UNF only for H6028BR/H6028BRO/ H6033BR/H6033BRO		76	Latch Rod 1	1
8	High Pressure Supply Hose	1	43	BoltM12×85	2	77	Cotter Pin 4×50	2
9	Latch Rod 2	2	44	Key 3/16×30	1	78	Spring2	1
10	Beam Pivot Pin	1	45	Gear Pump Connector Right	1	79	Key 3×25	1
11	Cylinder	1	46	Elastic Spider Block	1	80	Bracket Weldment	1
12	Bolt M14×85	1	47	Bolt M6×8	4	81	Bolt M8×25	4
13	Washer 14	3	48	Gear Pump Connector Left	1	82	Nut M8	4
14	Wedge	1	49	Gear Pump	1	83	Bolt M8×40	4
15	Locknut M14	1	50	Bolt M8×20	6	84	Beam Lock Bracket	1
16	Beam Weldment	1	51	Outlet connector of Pump	1			
17	Washer 6	6	52	Bolt M6×16	6			
18	Beam Pivot Pin	1	53	Washer 6	6			
19	Pin 6×40	2	54	Flange of filter	1			
20	Beam Pivot Pin	1	55	O-Ring D81×3.1	1			
21	Dipstick	1	56	Return oil filter	1			
22	Bridge Pin φ 4	1	57	Suction Hose	1			
23	Pivot Bracket	1	58	Clamp18-32	2			
24	Washer 10	8	59	Manual Tube	1			
25	Bolt M10×30	4	60	Nut M10	5			
26	Spring1	1	61	Flat Washer 10	4			
27	Flat Washer 12	9	62	Safety Chain	2			
28	Spring Washer 12	4	63	Support leg Weldment	1			
29	Nut M12	4	64	Latch Rod 2	1			
30	Tank Assembly	1	65	Bridge Pin φ 3	1			
31	Nut M8	4	66	Clamp25-38	2			
32	Spring Washer 8	12	67	2" Ball Coupler Hitch	1			
33	Washer 8	22	68	Bolt M12×80	2			
34	Engine	1	69	Bolt M10×85	1			
35	Washer 8 GB/T96	4						
36	Safety Clasp	2						

LOG CATCHER (SOLD SEPARATELY)

No.	Description	Qty
1*	Log Catcher	1
2*	Bolt M10×30	2
3*	Nut M10	2
4*	Flat Washer 10	2

H6038FB / H6038FB0 / H6038BR / H6038BR0

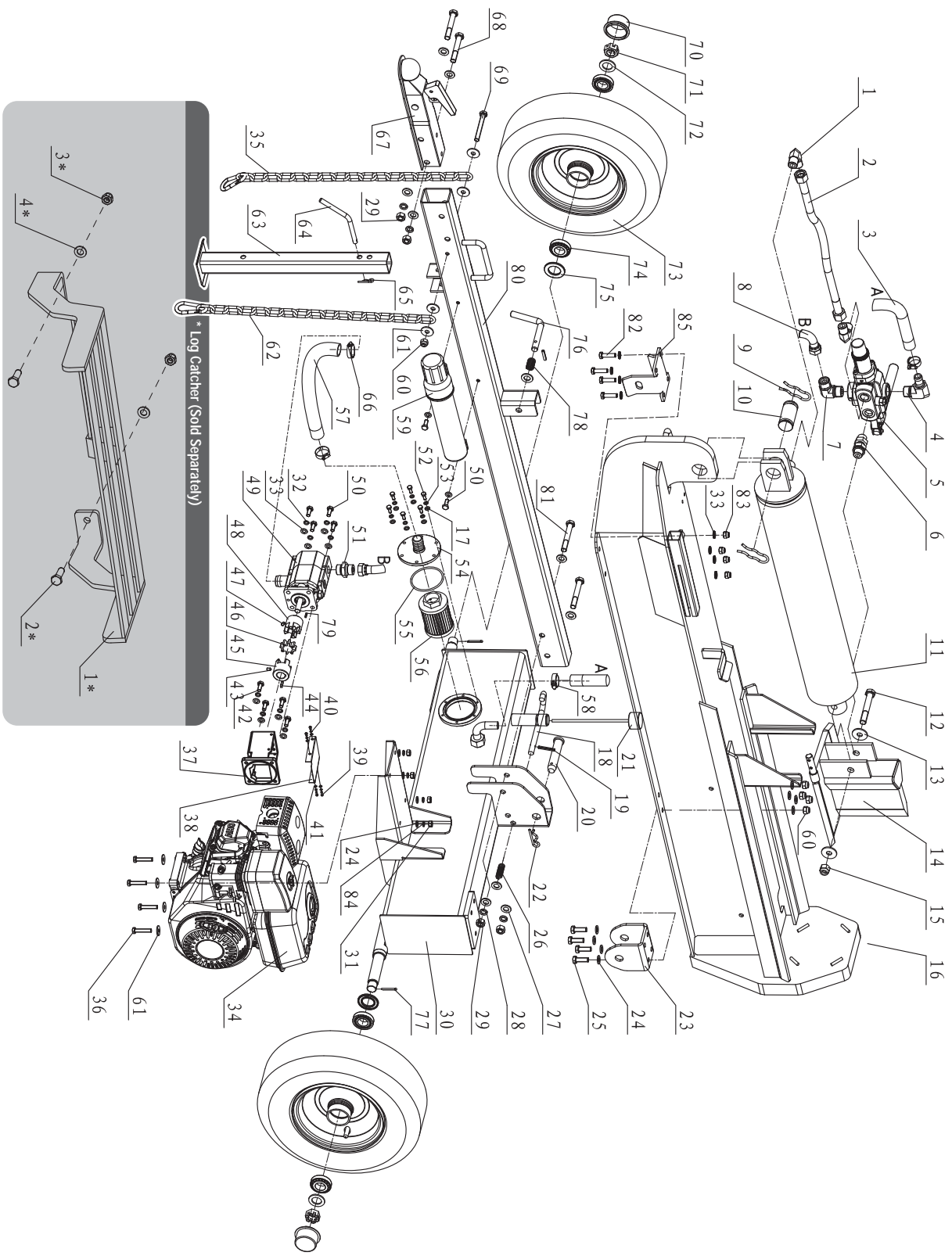

H6038FB/H6038FBO/H6038BR/H6038BRO PARTS LIST

No.	Description	Qty	No.	Description	Qty	No.	Description	Qty
1	Right-Angle Fitting 1/2"	2	37	Pump Bracket	1	71	Axle Nut M22	2
2	Welded Hose	1	38	Cover of Pump Bracket	1	72	Wheel Washer 22	2
3	Low Pressure Return Hose	1	39	Screw M5×10	4	73	Tire	2
4	Right-Angle Fitting 1	1	40	Spring Washer 5	4	74	Bearing	4
5	Control Valve	1	41	Washer 5	4	75	Anti-Dust Washer	2
6	Valve Straight Fitting 1/2"	1	42	Bolt M8×25 only for H6038FB/H6038FBO	4	76	Latch Rod 1	1
7	Right-Angle Fitting 1	1		Bolt 5/16-24 UNF only for H6038BR/H6038BRO		77	Cotter Pin 4×50	2
8	High Pressure Supply Hose	1	43	Bolt M8×10	2	78	Spring2	1
9	Latch Rod 2	2	44	Key 1/4×50	1	79	Key 3×25	1
10	Beam Pivot Pin	1	45	Gear Pump Connector Right	1	80	Bracket Weldment	1
11	Cylinder	1	46	Elastic Spider Block	1	81	Bolt M12×85	2
12	Bolt M14×85	1	47	Bolt M6×8	2	82	Bolt M8×25	4
13	Washer 14	3	48	Gear Pump Connector Left	1	83	Nut M8	4
14	Wedge	1	49	Gear Pump	1	84	Spring Washer 10	4
15	Locknut M14	1	50	Bolt M8×20	6	85	Beam Lock Bracket	1
16	Beam Weldment	1	51	Outlet connector of Pump	1			
17	Washer 6	6	52	Bolt M6×16	6			
18	Beam Pivot Pin	1	53	Washer 6	6			
19	Pin 6×40	2	54	Flange of filter	1			
20	Beam Pivot Pin	1	55	O-Ring D81×3.1	1			
21	Dipstick	1	56	Return oil filter	1			
22	Bridge Pin ϕ 4	1	57	Suction Hose	1			
23	Pivot Bracket	1	58	Clamp18-32	2			
24	Washer 10	12	59	Manual Tube	1			
25	Bolt M10×30	4	60	Nut M10	5			
26	Spring1	1	61	Flat Washer 10	8			
27	Flat Washer 12	9	62	Safety Chain	2			
28	Spring Washer 12	4	63	Support leg Weldment	1			
29	Nut M12	4	64	Latch Rod 2	1			
30	Tank Assembly	1	65	Bridge Pin ϕ 3	1			
31	Nut M10	4	66	Clamp25-38	2			
32	Spring Washer 8	8	67	2" Ball Coupler Hitch	1			
33	Washer 8	16	68	Bolt M12×80	2			
34	Engine	1	69	Bolt M10×85	1			
35	Safety Clasp	2	70	Dust Cap	2			
36	Bolt M10×45	4						

LOG CATCHER (SOLD SEPARATELY)

No.	Description	Qty
1*	Log Catcher	1
2*	Bolt M10×30	2
3*	Nut M10	2
4*	Flat Washer 10	2

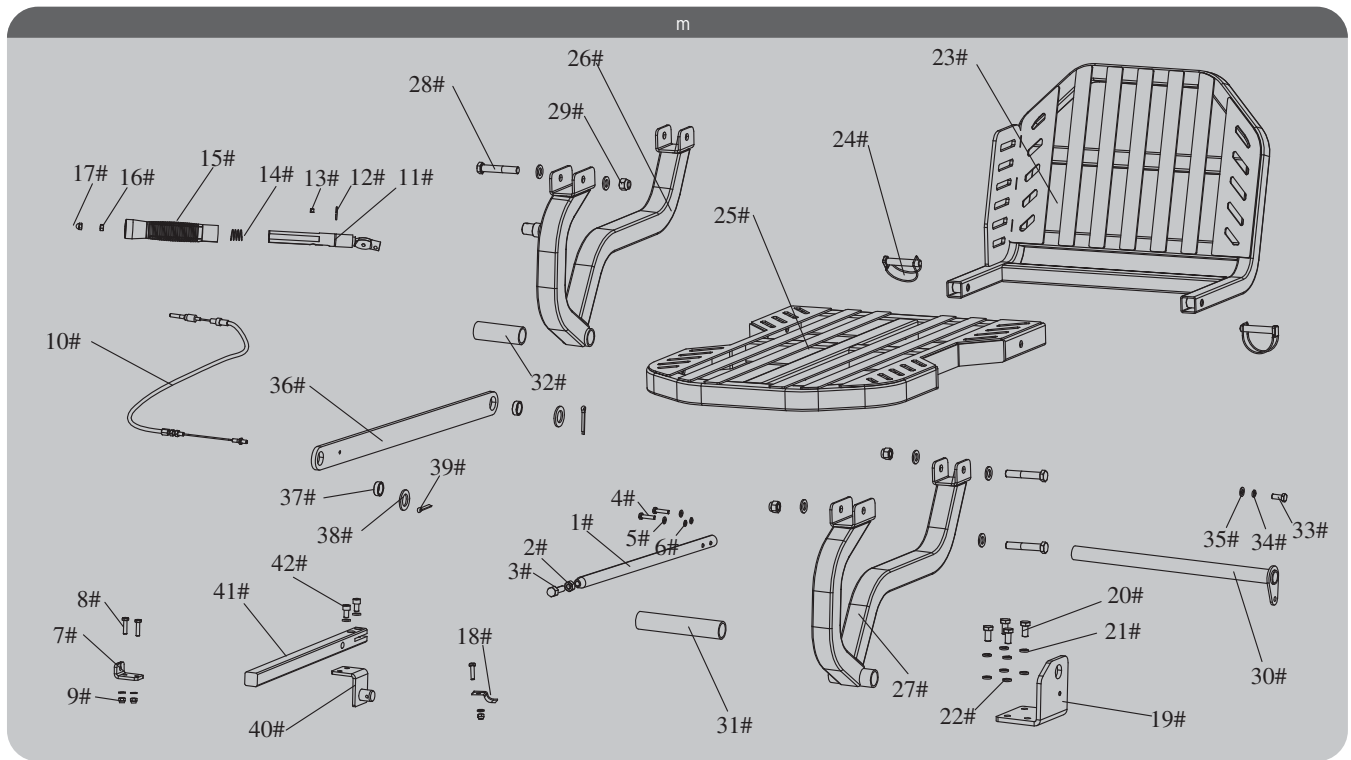

LOG LIFT TABLE ATTACHMENT (SOLD SEPARATELY) PARTS LIST

No.	Description	Qty
1#	Ejector Rod	1
2#	Nut M10	1
3#	Round Head Bolt M10x40	1
4#	Bolt M6x20	3
5#	Flat Washer 6	5
6#	Spring Washer 6	2
7#	Cable Fixing Plate	1
8#	Bolt M6x25	2
9#	Nut M6	3
10#	Cable	1
11#	Handle	1
12#	Circlips 20	1
13#	Hexagon Socket Set Screw M6x10	1
14#	Spring	1
15#	Handle Grip	1
16#	Nut M6	1
17#	Round Head Nut M6	1
18#	Cable Holder	1
19#	Connecting Plate	1
20#	Bolt M10x20	4

No.	Description	Qty
21#	Spring Washer 10	4
22#	Flat Washer 10	10
23#	Log Lift Table Attachment-side Table	1
24#	D type Pin 10x60	2
25#	Log Lift Table Attachment-main Table	1
26#	Support Leg-left	1
27#	Support Leg-right	1
28#	Bolt M10x70	3
29#	Nut M10	3
30#	Rotating Shaft	1
31#	Long Bushing	1
32#	Short Bushing	1
33#	Bolt M8x20	1
34#	Spring Washer 8	3
35#	Flat Washer 8	1
36#	Swing Arm	1
37#	Bushing 25x20x8	2
38#	Flat Washer 20	2
39#	Cotter Pin 5x35	2
40#	Bending Plate	1
41#	Slide-rail	1
42#	Hex Socket Head Cap Screw M8x16	2



GO FULL BOAR