

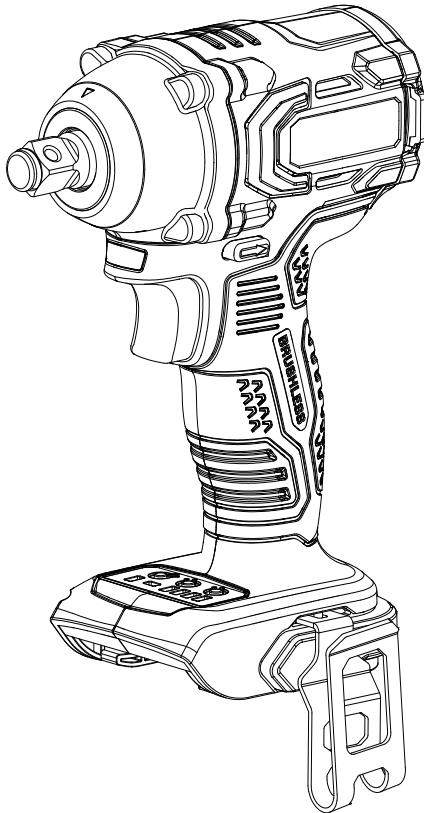

IMPACT WRENCH

Operator's manual
Model: PDWX2-M2
PDWX2-M2-0



For customer support, please call 1-800-261-3981 or send email to:
senix.service@yat.com
SAVE THIS MANUAL FOR FUTURE REFERENCE.

ORIGINAL INSTRUCTIONS

TABLE OF CONTENTS

SAFETY & INTERNATIONAL SYMBOLS	22
SAFETY INSTRUCTIONS.....	23
KNOW YOUR UNIT.....	30
SPECIFICATIONS.....	31
ASSEMBLY.....	32
OPERATION.....	34
MAINTENANCE.....	37
TROUBLESHOOTING.....	38
WARRANTY.....	40

SAFETY & INTERNATIONAL SYMBOLS

Explanation of safety & international symbols describes safety and international symbols and pictographs that may appear on this product. Read the operator's manual for complete safety, assembly, operating and maintenance and repair information.



Caution / Warning.



Use and store the battery within an temperature below 122°F (50°C).



To reduce the risk of injury, user must read instruction manual.



Do not disassemble, crush, heat above 212°F (100°C); Never expose the battery to microwaves or high pressures.



Wear eye protection.



Keep bystanders a safe distance away from the work area.



Wear a dust mask.



Indoor use only. Only use battery charger indoors.



Wear safety footwear.



Wear protective gloves.



Do not dispose of battery packs in rivers or immerse in water.



Do not dispose of battery packs in fire. They will explode and cause injury.

SAFETY INSTRUCTIONS

GENERAL POWER TOOL SAFETY WARNINGS

⚠ WARNING!

Read all safety warnings, instructions, illustrations and specifications, provided with this power tool. Failure to follow all instructions listed below may result in electric shock, fire and/or serious injury.

Save all warnings and instructions for future reference.

The term "power tool" in the warnings refers to your mains-operated (corded) power tool or battery-operated (cordless) power tool.

1) Work Area Safety

- Keep work area clean and well lit.** Cluttered or dark areas invite accidents.
- Do not operate power tools in explosive atmospheres, such as in the presence of flammable liquids, gases or dust.** Power tools create sparks which may ignite the dust or fumes.
- Keep children and bystanders away while operating a power**

tool. Distractions can cause you to lose control.

2) Electrical Safety

- Power tool plugs must match the outlet. Never modify the plug in any way. Do not use any adapter plugs with earthed (grounded) power tools.** Unmodified plugs and matching outlets will reduce risk of electric shock.
- Avoid body contact with earthed or grounded surfaces, such as pipes, radiators, ranges and refrigerators.** There is an increased risk of electric shock if your body is earthed or grounded.
- Do not expose power tools to rain or wet conditions.** Water entering a power tool will increase the risk of electric shock.
- Do not abuse the cord. Never use the cord for carrying, pulling or unplugging the power tool. Keep cord away from heat, oil, sharp edges or moving parts.** Damaged or entangled cords increase the risk of electric shock.

- e) **When operating a power tool outdoors, use an extension cord suitable for outdoor use.** Use of a cord suitable for outdoor use reduces the risk of electric shock.
- f) **If operating a power tool in a damp location is unavoidable, use a residual current device (RCD) protected supply.** Use of an RCD reduces the risk of electric shock.

3) Personal Safety

- a) **Stay alert, watch what you are doing and use common sense when operating a power tool. Do not use a power tool while you are tired or under the influence of drugs, alcohol or medication.** A moment of inattention while operating power tools may result in serious personal injury.
- b) **Use personal protective equipment. Always wear eye protection.** Protective equipment such as a dust mask, non-skid safety shoes, hard hat or hearing protection used for appropriate conditions will reduce personal injuries.
- c) **Prevent unintentional starting. Ensure the switch is in the off-**

position before connecting to power source and/or battery pack, picking up or carrying the tool. Carrying power tools with your finger on the switch or energising power tools that have the switch on invites accidents.

- d) **Remove any adjusting key or wrench before turning the power tool on.** A wrench or a key left attached to a rotating part of the power tool may result in personal injury.
- e) **Do not overreach. Keep proper footing and balance at all times.** This enables better control of the power tool in unexpected situations.
- f) **Dress properly. Do not wear loose clothing or jewellery. Keep your hair and clothing away from moving parts.** Loose clothes, jewellery or long hair can be caught in moving parts.
- g) **If devices are provided for the connection of dust extraction and collection facilities, ensure these are connected and properly used.** Use of dust collection can reduce dust-related hazards.
- h) **Do not let familiarity gained from frequent use of tools**

allow you to become complacent and ignore tool safety principles. A careless action can cause severe injury within a fraction of a second.

4) Power Tool Use And Care

- a) **Do not force the power tool. Use the correct power tool for your application.** The correct power tool will do the job better and safer at the rate for which it was designed.
- b) **Do not use the power tool if the switch does not turn it on and off.** Any power tool that cannot be controlled with the switch is dangerous and must be repaired.
- c) **Disconnect the plug from the power source and/or remove the battery pack, if detachable, from the power tool before making any adjustments, changing accessories, or storing power tools.** Such preventive safety measures reduce the risk of starting the power tool accidentally.
- d) **Store idle power tools out of the reach of children and do not allow persons unfamiliar with the power tool or these instructions to operate the**

power tool. Power tools are dangerous in the hands of untrained users.

- e) **Maintain power tools and accessories. Check for misalignment or binding of moving parts, breakage of parts and any other condition that may affect the power tool's operation. If damaged, have the power tool repaired before use.** Many accidents are caused by poorly maintained power tools.
- f) **Keep cutting tools sharp and clean.** Properly maintained cutting tools with sharp cutting edges are less likely to bind and are easier to control.
- g) **Use the power tool, accessories and tool bits etc. in accordance with these instructions, taking into account the working conditions and the work to be performed.** Use of the power tool for operations different from those intended could result in a hazardous situation.
- h) **Keep handles and grasping surfaces dry, clean and free from oil and grease.** Slippery handles and grasping surfaces do not allow for safe handling

and control of the tool in unexpected situations.

5) Battery Tool Use And Care

- a) **Recharge only with the charger specified by the manufacturer.** A charger that is suitable for one type of battery pack may create a risk of fire when used with another battery pack.
- b) **Use power tools only with specifically designated battery packs.** Use of any other battery packs may create a risk of injury and fire.
- c) **When battery pack is not in use, keep it away from other metal objects, like paper clips, coins, keys, nails, screws or other small metal objects, that can make a connection from one terminal to another.** Shorting the battery terminals together may cause burns or a fire.
- d) **Under abusive conditions, liquid may be ejected from the battery; avoid contact. If contact accidentally occurs, flush with water. If liquid contacts eyes, additionally seek medical help.** Liquid ejected from the battery may

cause irritation or burns.

- e) **Do not use a battery pack or tool that is damaged or modified.** Damaged or modified batteries may exhibit unpredictable behaviour resulting in fire, explosion or risk of injury.
 - f) **Do not expose a battery pack or tool to fire or excessive temperature.** Exposure to fire or temperature above 266°F(130°C) may cause explosion.
 - g) **Follow all charging instructions and do not charge the battery pack or tool outside the temperature range specified in the instructions.** Charging improperly or at temperatures outside the specified range may damage the battery and increase the risk of fire.
- ## 6) Service
- a) **Have your power tool serviced by a qualified repair person using only identical replacement parts.** This will ensure that the safety of the power tool is maintained.
 - b) **Never service damaged battery packs.** Service of

battery packs should only be performed by the manufacturer or authorized service providers.

SAFETY WARNINGS FOR IMPACT WRENCH

- a) Hold power tool by insulated gripping surfaces, when performing an operation where the fastener may contact hidden wiring. Fasteners contacting a “live” wire may make exposed metal parts of the power tool “live” and could give the operator an electric shock.
- b) Wear ear protectors when impact drilling. Exposure to noise can cause hearing loss.
- c) Use only sockets and other accessories specifically designed for use on impact wrenches and drivers. Other sockets and accessories might shatter or break causing injury.
- d) Always use common sense and be cautious when using tools. It is not possible to anticipate every situation that could result in a dangerous outcome. Do not use this tool if you do not understand these operating instructions or you feel the work is beyond your capability.
- e) Maintain labels and nameplates.

These carry important information. If unreadable or missing, contact the service facility for a free replacement.

SAFETY WARNING FOR BATTERY PACK AND BATTERY CHARGER

- Recharge only with the charger specified by the manufacturer. A charger that is suitable for one type of battery pack may create a risk of fire when used with another battery pack.
- Use appliances only with specifically designated battery packs. Use of any other battery packs may create a risk of injury and fire.

WARNING!

Only use following batteries: B20X2/ B25X2/B40X2/B50X2.

- When battery pack is not in use, keep it away from other metal objects, like paper clips, coins, keys, nails, screws or other small metal objects, that can make a connection from one terminal to another. Shorting the battery terminals together may cause burns or a fire.
- Under abusive conditions, liquid may be ejected from the

battery; avoid contact. If contact accidentally occurs, flush with water. If liquid contacts eyes, additionally seek medical help. Liquid ejected from the battery may cause irritation or burns.

(This advice is considered correct for conventional NiMh, NiCd, lead acid and lithium-ion cell types. If this advice is incorrect for a cell design that differs from these, then the correct advice may be substituted.)

- Do not use a battery pack or appliance that is damaged or modified. Damaged or modified batteries may exhibit unpredictable behavior resulting in fire, explosion or risk of injury.
- Do not expose a battery pack or appliance to fire or excessive temperature. Exposure to fire or temperature above 266°F(130°C) may cause explosion.
- Follow all charging instructions and do not charge the battery pack or appliance outside of the temperature range specified in the instructions. Charging improperly or at temperatures outside of the specified range may damage the battery and

increase the risk of fire.

- Do not modify or attempt to repair the appliance or the battery pack (as applicable) except as indicated in the instructions for use and care.

VIBRATION + NOISE REDUCTION

To reduce the impact of noise and vibration emission, limit the time of operation, use low-vibration and low-noise operating modes as well as wear personal protective equipment. Take the following points into account to minimise the vibration and noise exposure risks.

- Only use the product as intended by its design and these instructions.
- Ensure that the product is in good condition and well maintained.
- Use correct attachments for the product and ensure they are in good condition.
- Keep tight grip on the handles/ grip surface.
- Maintain this product in accordance with these instructions and keep it well lubricated (where appropriate).
- Plan your work schedule to spread any high vibration tool use across a longer period of

time.

EMERGENCY

Familiarize yourself with the use of this product by means of this instruction manual. Memorize the safety directions and follow them to the letter. This will help to prevent risks and hazards.

- Always be alert when using this product, so that you can recognize and handle risks early. Fast intervention can prevent serious injury and damage to property.
- Switch off the product and remove the battery pack if there are malfunctions. Have the product checked by a qualified professional and repaired, if necessary, before you operate it again.

INTENDED USE

This impact wrench is intended for tightening or loosening bolts and nuts. Do not use it for other purposes.

KNOW YOUR UNIT

APPLICATIONS

Model: PDWX2-M2

As a cordless impact wrench:
Tightening or loosening bolt or nut.

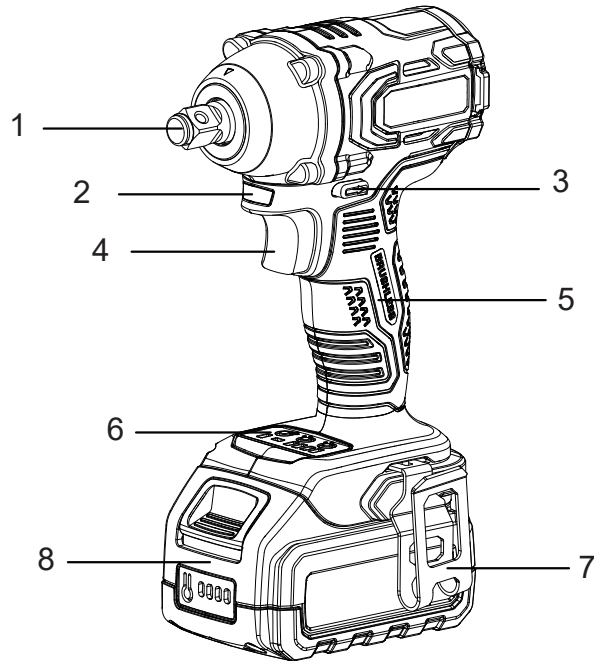



- | | |
|---------------------------|-----------------------|
| 1. Anvil | 5. Overmold Grip Area |
| 2. Work Light | 6. Control Panel |
| 3. Forward/Reverse Switch | 7. Belt Clip |
| 4. Variable Speed Trigger | 8. Battery Pack** |

NOTE:

**The lithium ion battery and charger are not included with PDWX2-M2-0.

*20V Max battery, maximum initial battery voltage (measured without a workload) is 20 volts.
The nominal voltage is 18.

SPECIFICATIONS

Model	PDWX2-M2			
Input voltage	18 V  (20 V Max)			
No Load Speed	0-1000/1800/1600/3200 rpm			
No Load IPM	0-1800/2600/3400/4000 ipm			
No Load Current	≤6.0A			
Average Operation Current	35-40 A			
Max Tightening Torque	245 ft./lbs. (330 Nm)			
Max Loosening Torque	365 ft./lbs. (580 Nm)			
Weight (without battery)	2.65 lb (1.2 kg)			
Battery model	B20X2	B25X2	B40X2	B50X2
Rated voltage	18 V  (20 V Max)			
Rated capacity	2.0 Ah	2.5 Ah	4.0 Ah	5.0 Ah
Weight	0.89 lbs (405 g)	0.89 lbs (405 g)	1.49 lbs (675 g)	1.49 lbs (675 g)
Charger model	CHX2		CHQX2	
Rated input	100 V - 240 V ~ 50 / 60 Hz			
Rated output	21 V, 2 A		21 V, 4 A	
Charging time (for 2.0 Ah battery)	65±5 min		35±5 min	
Charging time (for 2.5 Ah battery)	85±5 min		45±5 min	
Charging time (for 4.0 Ah battery)	135±5 min		65±5 min	
Charging time (for 5.0 Ah battery)	160±5 min		85±5 min	
Protection class (for charger)	 / II			
Weight	0.80 lbs (365 g)		0.91 lbs (415 g)	

ASSEMBLY

1. Unpack all parts and lay them on a flat, stable surface:
2. Remove all packing materials and shipping devices, if applicable.
3. The scope of delivery varies depending on the country and purchased variant:
Model of PDWX2-M2
 - Impact wrench x1
 - Belt clip x1
 - Screw x1
 - Battery pack x1
 - Charger x1
 - Instruction manual x1
4. If you find that parts are missing or show damage do not use the product but contact your dealer. Using an incomplete or damaged product represents a hazard to people and property.
5. Ensure that you have all the accessories and tools needed for assembly and operation. This also includes suitable personal protective equipment.

NOTE:

PDWX2-M2 includes the charger and the battery pack.
PDWX2-M2-0 does not include the charger and the battery pack.

WARNING:

Wear protective gloves for this assembly work and always lay the product on a flat and stable surface while assembling.

 Follow the assembly instructions step-by-step and use the pictures provided as a visual guide to easily assemble the product!

 Do not insert the battery pack before the power tool is completely assembled or adjusted!

BELT CLIP

Secure the belt clip on the tool by a screw.

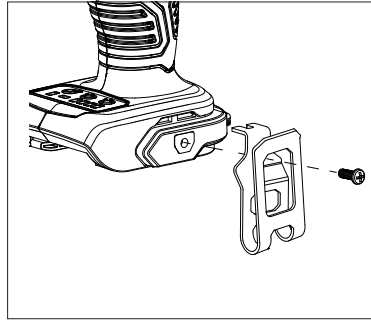

SOCKET



WARNING:

Only use accessories specifically recommended for this tool. An improper sized socket may cause hazard.
Always remove battery pack before changing or removing accessories.

To attach:

Align the accessory with the anvil and push it to the end.

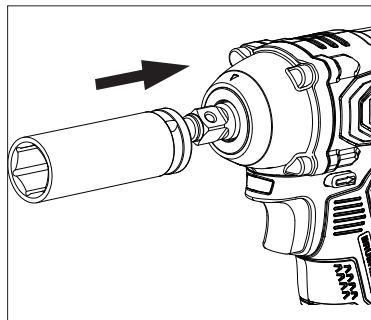

To remove:

Pull the accessory off the anvil.

BATTERY PACK



NOTE:

Prior to installation, lock the variable speed trigger by trigger lock to avoid unintentional start.

To install:

Align and slide the battery pack to the docking port of the tool until it is locked in place.

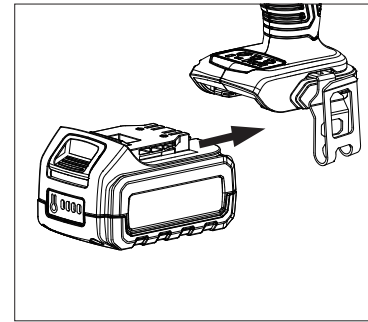

To remove:

Press the rail lock release button on battery pack and slide the battery pack out.

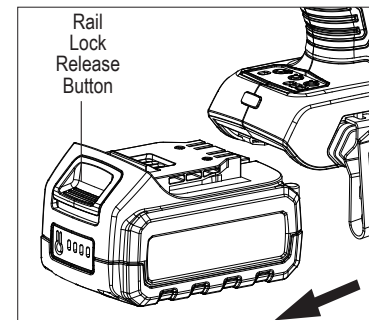

OPERATION



WARNING:

Always wear eye, hearing, hand protection to reduce the risk of injury when operating the tool. Keep all parts of your body away from the rotating bit.

ROTATION DIRECTION

The tool is designed to loosen or tighten bolts/nut. That depends on the rotation direction of spindle determined by the forward/reverse switch.



WARNING:

Do not change rotation direction while the product is running. Wait for a complete stop before performing setting.

Mode	Application
Forward	Tightening bolts.
Backward	Loosening bolts.
Center Lock	Lock the switch trigger.

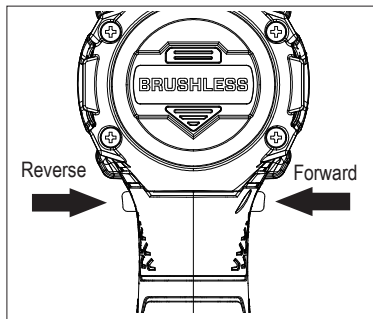

SPEED

A suitable working speed will ease your operation. Adjust to a desired speed in advance by pressing the speed control button.



WARNING:

To avoid damage to the product, only press the speed button when the power tool is completely stop.

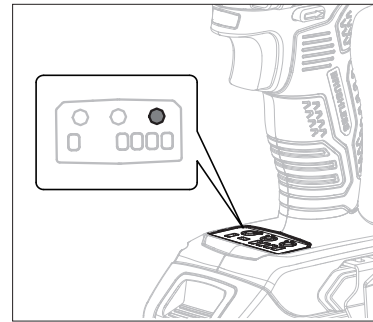

REVERSAL AUTO STOP

A fully loosened bolt is likely to fall off if you keep the variable speed trigger depressed under the reverse rotation mode.

Activate the reversal auto stop function, and the spindle will stop automatically after bolt/nut gets enough loosened even if the trigger continues to be engaged.

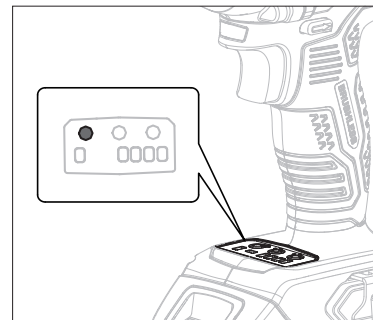

WORK LIGHT

This product is designed with a light for working in dim areas. Turn on the light and adjust brightness by pressing the button on the control panel. It shuts down automatically after product stops.

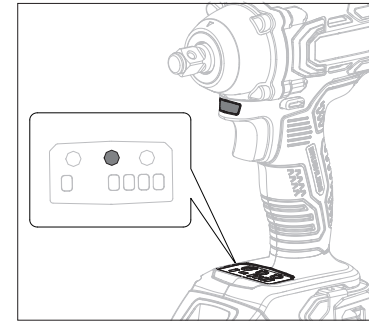

SWITCHING ON/OFF

1. Push the forward/reverse switch to left or right.
2. Press the trigger to start the product.
3. Release the trigger to stop the product.



NOTE:

Always lock the variable speed trigger before storage and any time not in use.

HOW TO CHARGE THE BATTERY PACK



WARNING:

This Lithium-Ion battery pack is shipped partially charged. Fully charge the battery pack before using it for the first time.



NOTE:

Charge batteries at a ambient temperature of 32°F - 104°F (0°C - 40°C).

1. Charge the Lithium-Ion battery pack only with the correct charger.
2. Connect the charger to a power supply, the light indicator of the charger turns red.
3. Align the raised ribs of the battery pack with the slot in the charger.
4. Insert the battery pack into the charger, the light indicator of the charger turns green and it flashes.
5. The charger will communicate with the battery pack to evaluate the condition of the battery pack.
6. The battery is fully charged when its four capacity indicators are illuminated. Disconnect the power supply from the charger. Remove battery pack from the charger.

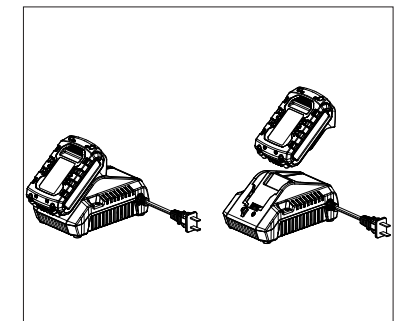

CAPACITY INDICATOR

Press the capacity indicator button on the battery pack to check whether it needs to charge.

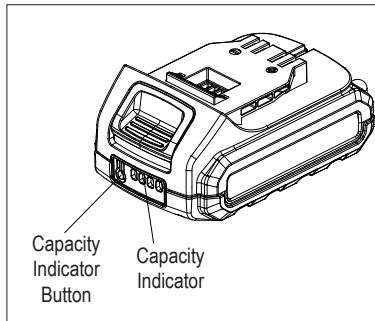

Lights			Remaining Capacity
Fully Lit	Off	Blinking	
			75% - 100%
			50% - 75%
			25% - 50%
			5% - 25%
			< 5% (need to be charged)



WARNING:

Four battery capacity indicators blinking in sequence may indicate a potential malfunction with the unit.

OVERHEAT PROTECTION

When the tool/battery is overheated, the tool stops automatically. In this situation, let the power tool/battery cool before turning the tool on again.

OVERDISCHARGE PROTECTION

When the battery capacity is not enough, the tool stops automatically. In this case, remove the battery from the tool and charge the battery.

IMPACTING TECHNIQUES

The longer a bolt, screw, or nut is impacted, the tighter it will become. To help prevent damaging the fasteners or workpieces, avoid excessive impacting. Be particularly careful when impacting smaller fasteners because they require less impacting to reach optimum torque.

Practice with various fasteners, noting the length of time required to reach the desired torque. Check the tightness with a hand-torque wrench. If the fasteners are too tight, reduce the impacting time. If they are not tight enough, increase the impacting time.

Oil, dirt, rust or other matter on the threads or under the head of the fastener affects the degree of tightness.

The torque required to loosen a fastener averages 75% to 80% of the tightening torque, depending on the condition of the contacting surfaces.

On light gasket jobs, run each fastener down to a relatively light torque and use a hand torque wrench for final tightening.

MAINTENANCE



WARNING:

Only perform cleaning and maintenance work according to these instructions! All further works must be performed by a qualified specialist!



WARNING:

TO PREVENT SERIOUS INJURY FROM ACCIDENTAL OPERATION: Make sure the trigger is locked and battery pack is removed before performing any procedure in this section. TO PREVENT SERIOUS INJURY FROM TOOL FAILURE: Do not use damaged equipments. If abnormal noise or vibration occurs, have the problem corrected before further use.

There are no user-serviceable parts in your power tool. If any of following condition are found, stop using it and send it to the authorized service center for repair.

- leaking, swollen, or cracked battery pack
- loose hardware
- misalignment or binding of accessories.
- cracked or broken parts.
- any other condition that may affect its safe operation.

CLEANING

1. Clean dust and debris from air vents.
2. Keep handle clean, dry and free of oil or grease.
3. Wipe up the anvil to ensure its smooth running.
4. Remove stubborn dirt from housing with high pressure air (max. 3 bar).
5. Never immerse your tool in liquid or allow a liquid to flow inside them.



NOTE:

Do not use chemical, alkaline, abrasive or other aggressive detergents or disinfectants to clean this product as they might be harmful to its surfaces.

TRANSPORTATION

1. Only carry by its handle.
2. Protect from any heavy impact or strong vibrations which may occur during transportation in vehicles.
3. Secure to prevent it from slipping or falling over.

STORAGE

1. Clean thoroughly as described above.
2. Store in a dark, dry, frost-free and well-ventilated area that is inaccessible to children. The ideal storage temperature is between 50°F - 86°F (10°C - 30°C).
3. Use original package for storage or cover with a suitable cloth to protect it against dust.



NOTE:

To prolong battery life, store the battery pack separately from the tool in a 30%-50% charged condition. It's recommended to have your battery pack charged at least every 6 months.

DISPOSAL

Waste product should not be disposed of with household waste. Please recycle where facilities exist. Check with your local authority or retailer for recycling advice.

Users should clean up the chips generated during operation to protect environment.



Electrical products should not be discarded with household products. Used electrical products must be collected separately and disposed of at collection points provided for this purpose. Talk with your local authorities or dealer for advice on recycling.

TROUBLESHOOTING

Suspected malfunctions are often due to causes that the users can fix themselves. Therefore, check the product using this section. In most cases the problem can be solved quickly.

PROBLEM	POSSIBLE CAUSE	SOLUTION
Product does not start	Forward/reverse switch at center locking position	Push forward/reverse switch to proper side
	Battery pack not properly attached	Attach properly
	Battery pack discharged	Charge the battery pack
Product does not reach full power	Battery pack capacity too low	Charge the battery pack
	Battery pack reaches its life cycle	Replace with new battery pack
Unsatisfactory result	Socket is damaged	Replace with new one
	Socket not suitable for intended operation	Use proper one

WARRANTY

SENIX TOOLS LIMITED WARRANTY

FOR FIVE YEARS from the date of purchase, this product is warranted against defects in material or workmanship. A defective product will be repaired or replaced free of charge. (**THREE YEARS** for the battery and the charger). For further detail on warranty coverage and warranty repair information, visit www.senix.com, call **1-800-261-3981**, or email us at senix.service@yat.com

- This warranty does not cover part failure due to normal wear or tool abuse.
- This warranty does not apply to accessories or damage caused where repairs have been made or attempted by others.
- This warranty does not cover the cost of transporting the product for warranty.
- The warranty is void if the product has been used for commercial, professional, or rental service purposes.
- The warranty applies to the original retail purchaser and is not transferable
- Proof of purchase is required.

THIS WARRANTY IS GIVEN IN LIEU OF ALL OTHERS, INCLUDING THE IMPLIED WARRANTY OF MERCHANTABILITY AND FITNESS FOR A PARTICULAR PURPOSE, AND EXCLUDES ALL INCIDENTAL OR CONSEQUENTIAL DAMAGE. Some states do not allow limitations on how long an implied warranty lasts or the exclusion or limitation of incidental or consequential damages, so these limitations may not apply to you. This warranty gives you specific legal rights and you may have other rights which vary in certain states or provinces.

NOTE: Battery warranty voided if the battery pack is tampered with in any way. SENIX is not responsible for any injury caused by tampering and may prosecute warranty fraud to the fullest extent permitted by law.

90-DAY MONEY-BACK GUARANTEE. If you are not completely satisfied with the performance of your SENIX Power Tool for any reason, you can return it within 90 days from the date of purchase with a receipt for a full refund.

Latin America: This warranty does not apply to products sold in Latin America. For products sold in Latin America, see the country-specific warranty information contained in the packaging, call the retailer from which it was purchased, or visit the website for warranty information.

Free warning label replacement: If your warning labels become illegible or are missing, call **1-800-261-3981** for a free replacement.

REGISTER ONLINE - www.senixtools.com/pages/product-registration

Thank you for your purchase! Register your product now for:

Warranty Service: Registering your product will help you obtain more efficient warranty service in case of a problem with your product.

Confirmation of Ownership: In case of an insurance loss, such as fire, flood, or theft, your ownership registration will serve as proof of purchase.

For your safety: Registering your product will allow us to contact you in the unlikely event a safety notification is required under the Federal Consumer Safety Act.



YAT USA INC. 10506 Bryton Corporate Center Dr, #500 Huntersville, NC 28078
For customer support, please call 1-800-261-3981 or email us at senix.service@yat.com