

# DEWALT®



Instruction Manual

**DXWP61374**

**DXWP61379**

**DXWP61774**

**DXWP61779**

**Aluminum Submersible Utility Pump**



**[www.DEWALT.com](http://www.DEWALT.com)**

**If you have questions or comments, contact us.**

**1-855-222-3841**

**[customer.service@pedrollo-usa.com](mailto:customer.service@pedrollo-usa.com)**



Index	
Content	Page #
Components	2
Safety Guidelines	3
Description	4
Specifications	4
Installation	5
Operation	5
Maintenance	6
Troubleshooting	6
Performance	7
Parts	8
Notes	9-10
Warranty	11

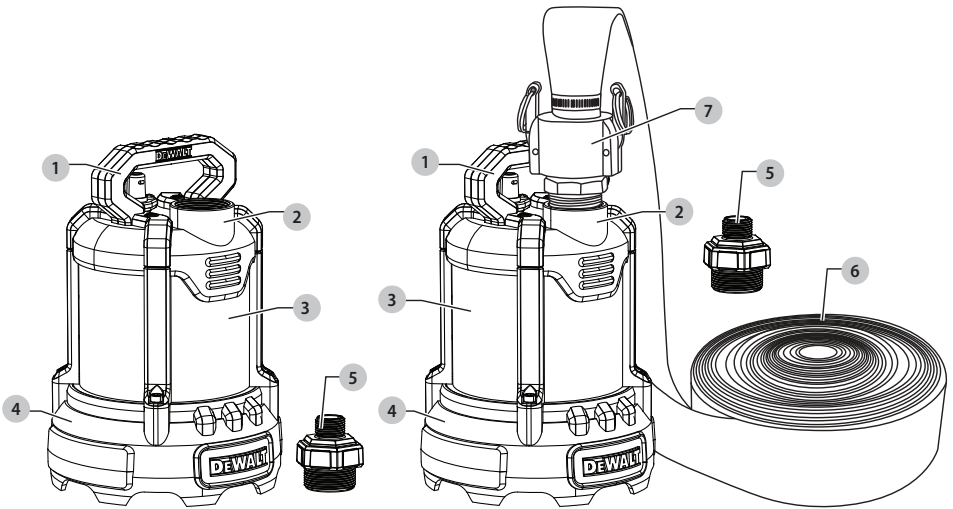

### Components

- 1 Handle
- 2 1-1/2 in. (38.1mm) NPT Discharge
- 3 Motor
- 4 Base
- 5 3/4 in. (19.05mm) GHT Adapter
- 6 Industrial Hose
- 7 Camlock Fittings



## Safety Guidelines

Carefully read, understand and follow all safety instructions in this manual. Retain this manual for future reference



This is the safety alert symbol. When you see this symbol, look for one of the following signal words.

## Important

Read these warnings carefully. Know the application and limitations of this pump. Failure to follow these warnings could result in serious bodily injury and/or property damage.

**⚠ DANGER:** Indicates a hazardous situation which, if not avoided, **will** result in **death or serious injury**.

**⚠ WARNING:** Indicates a hazardous situation which, if not avoided, **could** result in **death or serious injury**.

**⚠ CAUTION:** Indicates a hazardous situation which, if not avoided, **could** result in **minor or moderate injury**.

**⚠ NOTICE:** Indicates to address practices **not related to personal injury**.

### ⚠ WARNING RISK OF ELECTRICAL SHOCK:

Disconnect and lockout power supply before removing existing pump or installing or servicing this pump.

**⚠ WARNING RISK OF ELECTRICAL SHOCK:** This pump is supplied with a grounding conductor and grounding type attachment plug. To reduce the risk of electric shock, connect only to a properly grounded GFCI receptacle.

**⚠ WARNING RISK OF ELECTRICAL SHOCK:** Connect only to a receptacle that is adequately rated for the voltage and amperage of this pump.

**⚠ WARNING:** The installation of this pump must be in accordance with the National Electric Code (NEC), Uniform Plumbing Code (UPC), International Plumbing Code (IPC) as well as all applicable local codes and ordinances.

**⚠ WARNING:** Do not install this pump in any location classified as hazardous by the National Electrical Code, ANSI/NFPA70.

**⚠ DANGER:** Do not use this pump to pump corrosive, flammable or explosive fluids such as gasoline, kerosene, etc. Do not use this pump in flammable or explosive environments. The pump has been investigated for use with water only.

**⚠ WARNING RISK OF ELECTRICAL SHOCK:** This pump has not been investigated for use in swimming pool or marine areas.

**⚠ WARNING RISK OF ELECTRICAL SHOCK:** Do not use the power cord to handle, carry, or lower the pump. The cord may pull apart exposing bare wires which could cause a fire or electrical shock. Use the handle supplied with the pump for installing and removing.

**⚠ WARNING:** Do not expose the pump to freezing temperatures. Discharge lines exposed to freezing temperatures should be positioned with a downward slope to prevent freezing.

**⚠ WARNING:** All wiring and electrical connections must be performed by a qualified electrician.

**⚠ WARNING:** Make certain that the electrical outlet is within the reach of the power supply cord. **DO NOT USE AN EXTENSION CORD.**

**⚠ WARNING:** Do not run the pump dry. This pump relies on water for lubrication and cooling. Running the pump dry can cause the pump to overheat and risks the possibility of burns to anyone that handles the pump. Running the pump dry will void the warranty.

**⚠ WARNING:** Do not use this pump for potable/drinking water. Use only in applications for which the pump is designed.

**⚠ WARNING:** According to the state of California (Prop 65), this product contains chemicals known to the state of California to cause cancer and birth defects or other reproductive harm.

**⚠ WARNING: DO NOT UNDER ANY CIRCUMSTANCES REMOVE THE GROUND PIN.** The 3-prong plug must be inserted into a mating 3-prong grounded receptacle. If the installation does not have such a receptacle, it must be changed to the proper type, wired and grounded in accordance with the National Electrical Code and all applicable local codes and ordinances.

**⚠ WARNING:** This pump is not intended to pump water softener discharge (brine) or condensate high efficiency appliances. These liquids are corrosive and could cause damage to the pump and will void the warranty.

**⚠ CAUTION:** If a flexible discharge hose is used, make sure the pump is secured to prevent movement.

**⚠ WARNING:** Keep hands clear of suction and discharge openings. To prevent injury, never insert fingers into pump while it is plugged in.

**⚠ WARNING:** Do not handle this pump with wet hands or while standing on wet or damp surfaces or in water.

**⚠ CAUTION:** This pump motor is equipped with an automatic resetting thermal protector and may restart unexpectedly.

**⚠ NOTICE:** This pump is not designed as a waterfall, pond or fountain pump. Use of this pump for waterfalls, ponds or fountains will void the warranty.

## Description

This non-automatic submersible utility pump is designed to remove water from flooded basements, window wells, stock tanks, etc. The permanent split capacitor motor is oil cooled and hermetically sealed for cooler operation. The pump comes equipped with a 3-prong grounding type power cord.

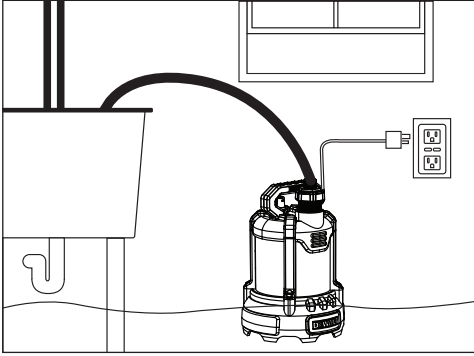

Shown using DeWALT® garden hose adapter (included) with standard garden hose (not included)

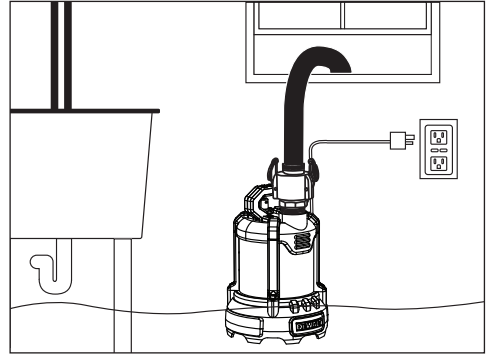

Shown using DeWALT® Industrial Hose with Camlock Fittings (included in "kit" models only)

## Specifications

	<b>DXWP61374</b>	<b>DXWP61379</b>	<b>DXWP61774</b>	<b>DXWP61779</b>
Hose Kit	Not Included	Included	Not Included	Included
Garden Hose Adapter	Included	Included	Included	Included
HP	1/3	1/3	3/4	3/4
Volts	115 Volt AC	115 Volt AC	115 Volt AC	115 Volt AC
Amps	5	5	9.1	9.1
Hz	60	60	60	60
Phase	1	1	1	1
Discharge Size	1-1/2 in. (38.1mm) NPT	1-1/2 in. (38.1mm) NPT	1-1/2 in. (38.1mm) NPT	1-1/2 in. (38.1mm) NPT
Adapter Size	3/4 in. (19.05mm) GHT	3/4 in. (19.05mm) GHT	3/4 in. (19.05mm) GHT	3/4 in. (19.05mm) GHT
Max. Solids Handling	3/8 in. (9.53mm)	3/8 in. (9.53mm)	3/8 in. (9.53mm)	3/8 in. (9.53mm)
Liquid Temp. Range	35°F - 120°F (1.7°C - 48.9°C)	35°F - 120°F (1.7°C - 48.9°C)	35°F - 120°F (1.7°C - 48.9°C)	35°F - 120°F (1.7°C - 48.9°C)
Cord Length	20 ft. (6.1m)	20 ft. (6.1m)	20 ft. (6.1m)	20 ft. (6.1m)
Pump Construction	Aluminum	Aluminum	Aluminum	Aluminum
Impeller	Thermoplastic	Thermoplastic	Thermoplastic	Thermoplastic
Motor Shaft	Stainless Steel	Stainless Steel	Stainless Steel	Stainless Steel
Shaft Seal	Carbon/Ceramic/ Stainless Steel	Carbon/Ceramic/ Stainless Steel	Carbon/Ceramic/ Stainless Steel	Carbon/Ceramic/ Stainless Steel
Fasteners	Stainless Steel	Stainless Steel	Stainless Steel	Stainless Steel
Max Vertical Lift	35 ft. (10.7m)	35 ft. (10.7m)	41 ft. (12.5m)	41 ft. (12.5m)
Max. PSI	15.2	15.2	17.8	17.8

## Installation

**⚠ WARNING:** Always disconnect the power source before attempting to install, service or perform maintenance on the pump. Failure to do so may result in fatal electrical shock. Always disconnect the power source before servicing pump.

**⚠ NOTICE:** Your pump is designed and built to give you reliable performance and long life. It will pump water for years when properly installed in the right environment.

**⚠ NOTICE:** A qualified electrician must perform all wiring.

### Assembly DXWP61374 and DXWP61774

- Garden Hose:** Thread the 3/4 in. (19.05mm) garden hose adapter into the pump discharge. Attach a garden hose (sold separately) to the garden hose adapter. Extend the hose, making sure there are no kinks or tight bends. NOTE: To keep friction loss as low as possible, do not use a hose that is smaller than 1/2 in. (12.7mm) inside diameter.
- Other Hose\* or Pipe\*:** Attach hose and fittings as required (sold separately) directly into the discharge. Extend the hose making sure there are no kinks or tight bends. NOTE: To keep friction loss as low as possible, do not use a hose that is smaller than 1/2 in. (12.7mm) inside diameter.

### Assembly DXWP61379 and DXWP61779

- Industrial Hose:** Thread the male camlock adapter (included) into the pump discharge. Connect the female camlock fitting (with hose, included) to the male adapter and secure. Extend the hose, making sure there are no kinks or tight bends in the hose.
- Garden Hose:** Thread the 3/4 in. (19.05mm) garden hose adapter into the pump discharge. Attach a garden hose (sold separately) to the garden hose adapter. Extend the hose, making sure there are no kinks or tight bends. NOTE: To keep friction loss as low as possible, do not use a hose that is smaller than 1/2 in. (12.7mm) inside diameter.
- Other Hose\* or Pipe\*:** Attach hose and fittings as required (sold separately) directly into the discharge. Extend the hose making sure there are no kinks or tight bends. NOTE: To keep friction loss as low as possible, do not use a hose that is smaller than 1/2 in. (12.7mm) inside diameter.

## Installation

- Install the pump on a hard level surface in the water. If necessary, place bricks or patio blocks under the pump to raise it off the bottom. Do not place the pump directly in mud, sand or silt.

## Operation

- Connect the power cord to a 115 volt AC grounded GFCI receptacle.

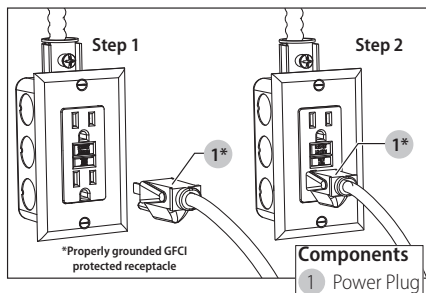

- The pump requires approximately 2 in. (50.8 mm) of water to prime. Once primed the pump will drain down to approximately 1/2 in. (12.7 mm) of the surface.
- The pump will continuously operate until disconnected from power. Do not let the pump run dry. The pump relies on water for lubrication and cooling. Operating the pump without water may cause the motor to overheat or cause damage to internal components. It may also shorten the life of the pump.
- The pump motor is thermally protected. It is not recommended for pumping liquids over 120°F (48.9°C). The thermal overload protector will automatically shut down the pump in an overheat/overload situation. The motor will reset itself once it cools. This device is designed as a safety device and should not be relied upon to operate the pump. The thermal overload will fail after repeated use.

## Maintenance

**⚠ WARNING: Risk of electric shock.** Always disconnect the power supply before attempting to install, service or perform maintenance on the pump.

**⚠ WARNING:** All repairs must be made by a qualified technician.

**⚠ CAUTION:** This submersible pump contains oil which may become pressurized and hot under normal operating conditions – allow the pump to cool for 2-3 hours before servicing.

1. The pump motor is hermetically sealed in the housing and does not require any service. Disassembly of the motor housing or modification of the power cord voids the warranty.
2. Periodically check the intake for obstructions. Clean if necessary.
3. Inspect the power cord for signs of damage or wear. Do not operate the pump if the cord is damaged or worn.
4. Clean off any accumulated sediment or debris to keep pump in optimal operating condition.

## Troubleshooting

Problem	Possible Causes	How To Correct
If the pump does not start or run	Pump is not plugged in, switch or breaker is off	Plug pump in or turn on switch/breaker
	Check for blown fuses or tripped circuit breakers or tripped GFCI outlets	Replace fuse, reset circuit breaker, reset GFCI outlet
	Motor thermal protector tripped	Allow pump to cool. Pump will automatically reset
If the pump runs but moves little or no water	Clogged intake	Remove clog or obstruction
	Clogged discharge hose/pipe	Remove clog or obstruction
	Impeller obstructed	Remove obstruction/debris
	Frozen discharge hose/pipe	Allow hose/pipe to thaw
	Low line voltage	Check wire size and increase if necessary
	Worn, damaged or clogged pump parts	Inspect for wear, damage or clog and clean or replace if necessary
Discharge height exceeds pump capacity	See performance chart for pump limitations	

## Performance

Height and/or piping restriction will reduce the pump output performance. It is recommended to use the same size or larger pipe as the pump discharge for optimum performance.

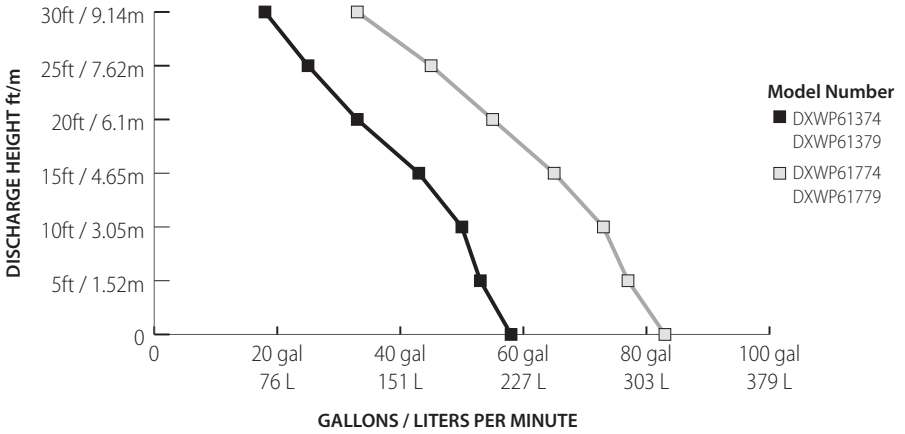

### Gallons Per Minute @ Discharge Height

Model	0 ft.	5 ft.	10 ft.	15 ft.	20 ft.	25 ft.	30 ft.	35 ft.	Max Lift
DXWP61374 DXWP61379	60	53	50	43	33	25	18	2	35 ft.
DXWP61774 DXWP61779	83	77	73	65	55	45	33	8	41 ft.

### Liters Per Minute @ Discharge Height

Model	0 m	1.52 m	3.05 m	4.65 m	6.1 m	7.62 m	9.14 m	10.6 m	Max Lift
DXWP61374 DXWP61379	227	201	189	163	125	95	68	8	10.7 m
DXWP61774 DXWP61779	314	291	276	246	208	170	125	95	12.5 m

# Replacement Parts

For parts, contact customer support at 855-222-3841 or customer.service@pedrollo-usa.com.

Utility Pump			
Reference	Description	DXWP61374	DXWP61774
1	Handle	ADW100000	ADW100000
2	Power Cord	F81130030	F81130030
3	Shaft Seal	T00900035/6	T00900035/6
4	Impeller	981040227	981040225
5	Adapter	G81200151	G81200151
*	Motor	NA	NA

\*If motor fails, replace entire pump.

Utility Pump Kit			
Reference	Description	DXWP61379	DXWP61779
1	Handle	ADW100000	ADW100000
2	Power Cord	F81130030	F81130030
3	Shaft Seal	T00900035/6	T00900035/6
4	Impeller	981040227	981040225
5	Adapter	G81200151	G81200151
*	Motor	NA	NA
6	Hose Clamp	C30010061	C30010061
7	Camlock Fitting (female)	G81200051	G81200051
8	Camlock Fitting (male)	G81200050	G81200050
9	25 ft. (7.62m) Industrial Discharge Hose	G81200188	G81200188

\*If motor fails, replace entire pump.

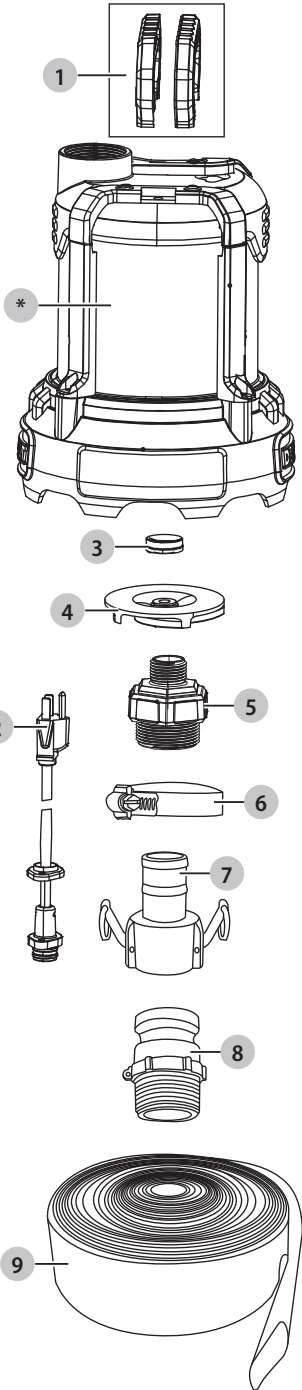

\*Not available for replacement





## Limited Warranty:

Manufacturer warrants the products specified in this warranty to be free from defects in material or workmanship for ten (10) years from date of purchase. During the time period and subject to the terms and conditions, manufacturer will repair or replace to the original user or consumer any portion of this product which proves to be defective due to materials or workmanship. At all times, manufacturer shall have and possess the sole right and option to determine whether to repair or replace defective equipment, parts or components. Manufacturer has the option to inspect any product returned under warranty to confirm that the warranty applies before repair or replacement under warranty is approved. This warranty sets forth manufacturer's sole obligation and purchaser's exclusive remedy for defective product. For warranty consideration, call **855-222-3841**

**or customer.service@pedrollo-usa.com.**

### Warranty Period:

If, within the duration of product use by the original user, this product proves to be defective due to materials or workmanship, the product shall be repaired or replaced at the manufacturer's option, subject to the terms and conditions set forth in this warranty statement. Proof of purchase is required for warranty consideration. In the absence of suitable proof of the purchase date, the effective period of this warranty is 12 months from the product's date of manufacture. If a warranty replacement pump is provided to the customer, the warranty of the replacement pump will be subject to the original purchase date of the original pump.

### Labor, ETC, Costs:

The manufacturer shall IN NO EVENT be responsible or liable for the cost of field labor or other charges incurred by any customer in removing and/or affixing any product, part, or component thereof.

### Product Improvements:

The manufacturer reserves the right to change or improve its products or any portions thereof without being obligated to provide such a change or improvement for units sold and/or shipped prior to such change or improvement.

### General Terms and Conditions:

This warranty shall not apply to damage due to acts of God, normal wear and tear, normal maintenance services and the parts used in connection with such service, lightning or conditions beyond the control of the manufacturer, nor shall it apply to products which, in the sole judgment of the manufacturer, have been subject to negligence, abuse, accident, misapplication, tampering, alteration; nor due to improper installation, operation, maintenance or storage; nor to excess of recommended maximums as set forth in the instructions.

## General Terms and Conditions - Cont:

Warranty will be VOID if any of the following conditions are found:

1. Product is used for purposes other than those for which it was designed and manufactured. Pump has been used for pumping liquids above 120°F (48.9°C).
2. Product is not installed in accordance with applicable codes, ordinances, and good trade practices.
3. Product is connected to voltage other than indicated on nameplate or labels.
4. Pump has been exposed to but not limited to the following: sand, gravel, cement, grease, plaster, mud, tar, oil, gasoline, solvents or other abrasive or corrosive substances.
5. Pump has been allowed to operate dry (liquid supply cut off).

### Disclaimer:

Any oral statements about the product made by the seller, the manufacturer, the representatives, or any other parties do not constitute warranties, shall not be relied upon by the user, and are not part of the contract for sale. Seller's and the manufacturer's only obligation, and buyer's only remedy, shall be the replacement and/or repair by the manufacturer of the product as described above. **NEITHER SELLER NOR THE MANUFACTURER SHALL BE LIABLE FOR ANY INJURY, LOSS OR DAMAGE, DIRECT, INCIDENTAL OR CONSEQUENTIAL (INCLUDING, BUT NOT LIMITED TO, INCIDENTAL OR CONSEQUENTIAL DAMAGES FOR LOST PROFITS, LOST SALES, INJURY TO PERSON OR PROPERTY, OR ANY OTHER INCIDENTAL OR CONSEQUENTIAL LOSS), ARISING OUT OF THE USE OR THE INABILITY TO USE THE PRODUCT, AND THE USER AGREES THAT NO OTHER REMEDY SHALL BE AVAILABLE TO IT.** Before using, the user shall determine the suitability of the product for their intended use, and user assumes all risk and liability whatsoever in connection therewith.

**THE WARRANTY AND REMEDY DESCRIBED IN THIS LIMITED WARRANTY IS AN EXCLUSIVE WARRANTY AND REMEDY AND IS IN LIEU OF ANY OTHER WARRANTY OR REMEDY, EXPRESSED OR IMPLIED, WHICH OTHER WARRANTIES AND REMEDIES ARE HEREBY EXPRESSLY EXCLUDED, INCLUDING BUT NOT LIMITED TO ANY IMPLIED WARRANTY OF MERCHANTABILITY OR FITNESS FOR A PARTICULAR PURPOSE, TO THE EXTENT EITHER APPLIES TO A PRODUCT SHALL BE LIMITED IN DURATION TO THE PERIODS OF THE EXPRESSED WARRANTIES GIVEN ABOVE.**

Some states and countries do not allow the exclusion or limitations on how long an implied warranty lasts or the exclusion or limitation of incidental or consequential damages, so the above exclusion or limitations may not apply to you. This warranty gives you specific legal rights, and you may also have other rights which vary from state to state.



**Dedicated Customer Support**

**855-222-3841**

customer.service@pedrollo-usa.com

Live customer support available 7 days a week.

**Manufactured under license by:**

**Pedrollo Group Inc.**

**45 Maryland Ave East**

**St. Paul, Minnesota 55117**

© 2022 DEWALT.

DEWALT®, GUARANTEED TOUGH® and the yellow/black color scheme are trademarks for DEWALT power tools, outdoor equipment, accessories, anchors and concrete adhesives and are used under license.

Product may differ from that pictured. Does not affect function.