

# CAT TOWER ASSEMBLY MANUAL

SKU# 2236143

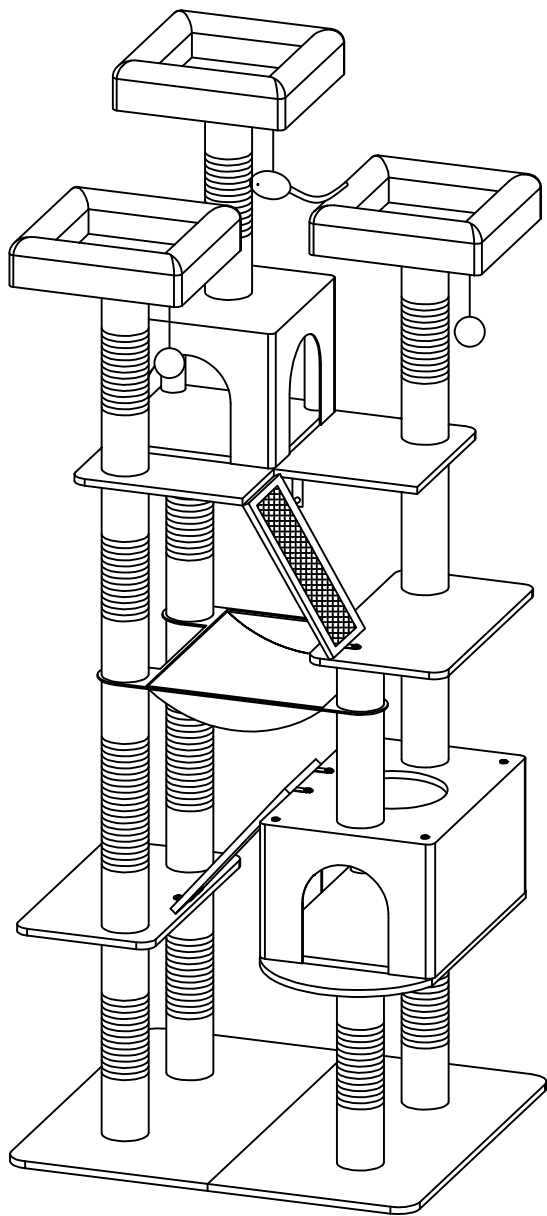









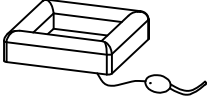
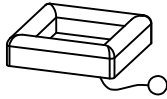
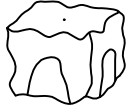

Tools required for assembly (not included)

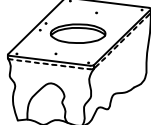

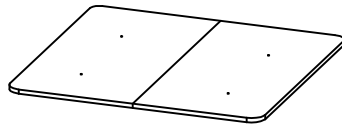
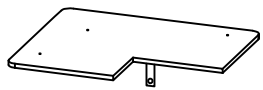
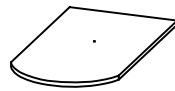



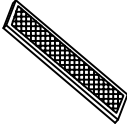











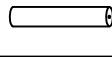

(included)

Distributed by: TRACTOR SUPPLY COMPANY  
5401 VIRGINIA WAY, BRENTWOOD, TN 37027  
For customer support, call: 1-888-376-9601  
[www.TractorSupply.com](http://www.TractorSupply.com)  
MADE IN CAMBODIA

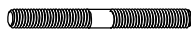
## PARTS LIST

Part#	Description	Drawing	Qty.
1	Square bed with a mouse		1
2	Square bed with a ball		2
3	Square cave cover		1
4	Top board of square cave		1
5	Bottom board of square cave		1
6	Rectangle cave		1
7	Bottom board of rectangle cave		1
8	Bottom plate		1
9	Lying plate,top,padded		1
10	Board		1
11	Lying plate,padded,left		1
12	Lying plate,padded,right		1
13	Scratching board, upper,11.2"(28.5cm) length		1
14	Scratching board, lower,13.6"(34.5cm) length		1
15	Hammock		1

## PARTS LIST

Part#	Description	Drawing	Qty.
16	Post, 17.7"(45cm)		2
17	Post with spacer bolt, 13.8"(35cm)		5
18	Post, 13.8"(35cm)		2
19	Post with spacer bolt, 12.2"(31cm)		1
20	Post, 12.2"(31cm)		1
21	Post, 8.3"(21cm)		3
22	Post with spacer bolt, 3.3"(8.5cm)		1
23	Post, 3.3"(8.5cm)		1
24	Post, 8.3"(21cm)		8
25	Flathead screw, M8*40mm		23+1
26	Flathead screw, M8*28mm		2
27	Flathead screw, M8*15mm		12+1
28	Thread rod, M8*80mm		9+1
29	Tapping screw, M4*48mm		1
30	Wall plug		1
31	Connecting bracket		6
32	Washer Ø35mm		1
33	Allen key		1

**Step 1**

- Attach the lying plates(#9 & #12) and posts(#17 #20 #19 #21 #22 #23) with thread rod,M8\*80mm(#28).

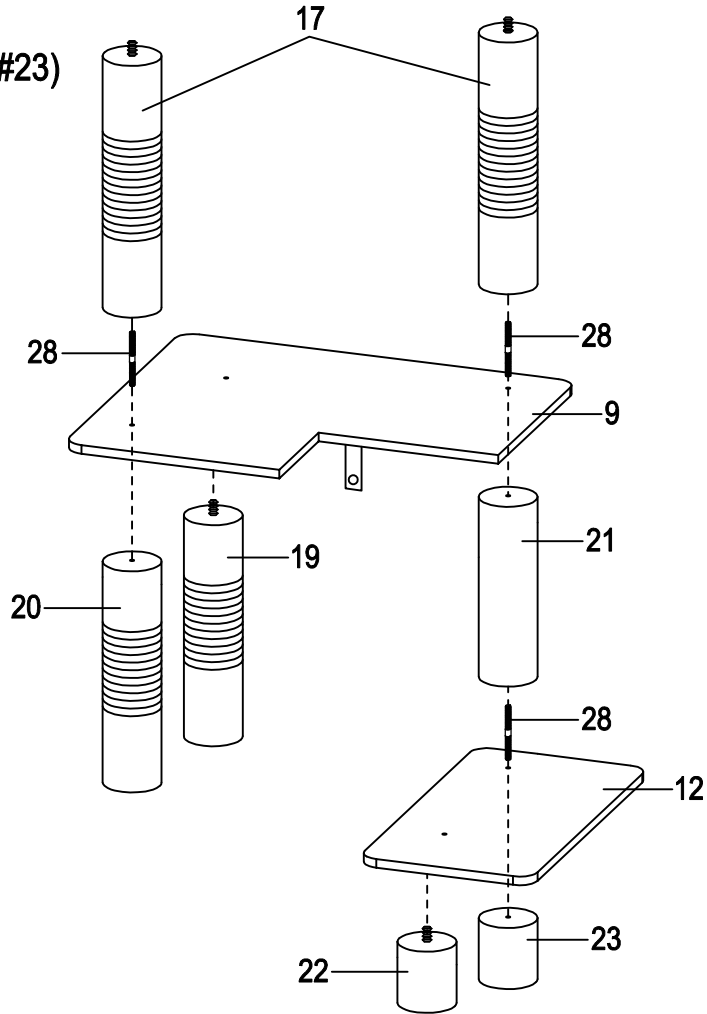

**Step 2**

- Assemble upper scratching board 11.2"(28.5cm) length(#13) with connecting bracket(#31) and flathead screw,M8\*15mm(#27).

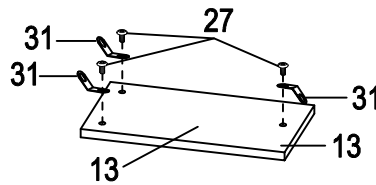

**Step 3**

- Attach upper scratching board 11.2"(28.5cm) length(#13) to the lying plates(#9 & #12) with flathead screw,M8\*15mm(#27).

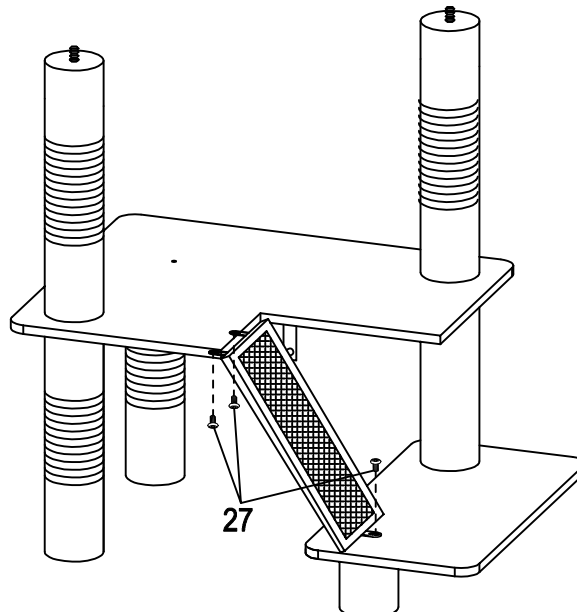

**Step 4**

- Assemble hammock(#15) and lower posts(#16 & #21) with thread rod, M8\*80mm(#28).

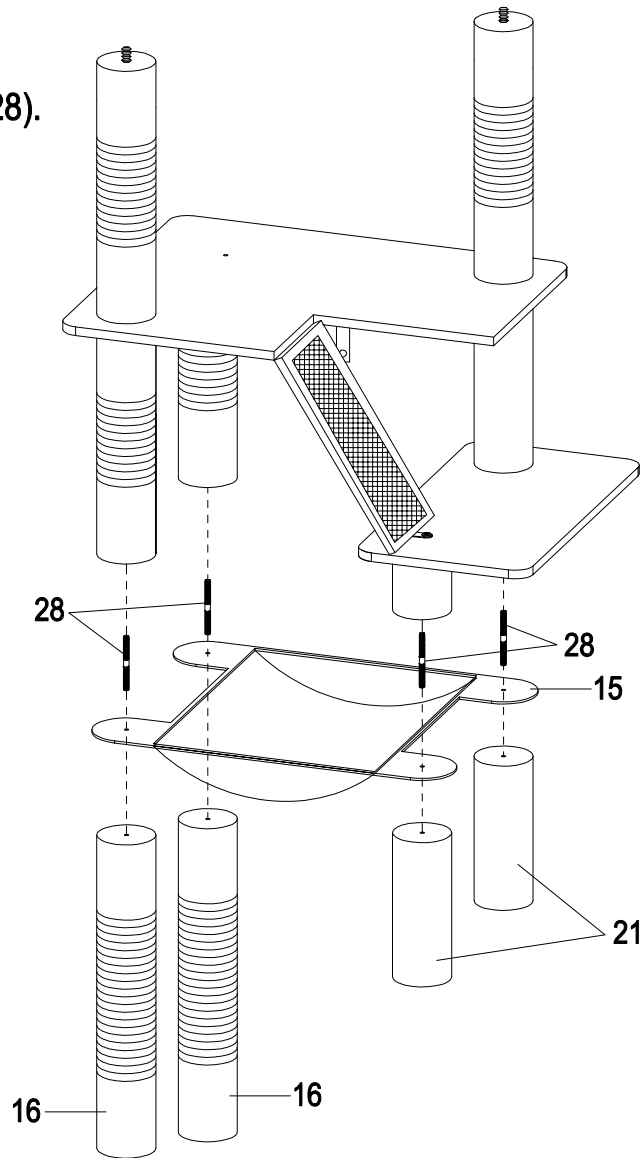
**Step 5**

- Assemble the rectangle cave(#6) & bottom board(#7) and posts(#24) with flathead screw. Make sure the edge of cover is well under bottom board(#7).

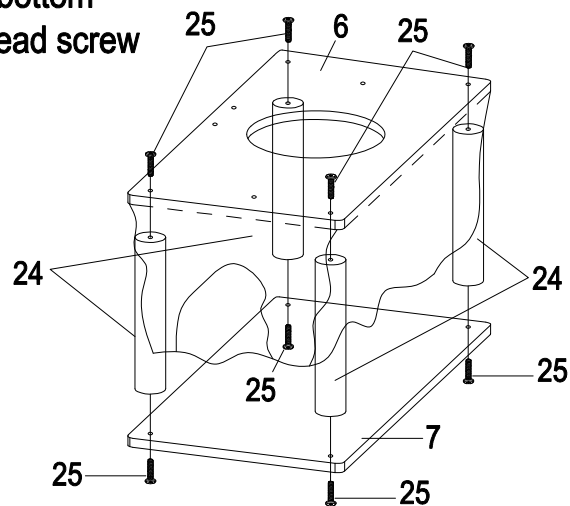

**Step 6**

- Attach the rectangle cave with flathead screw, M8\*40mm(#25).

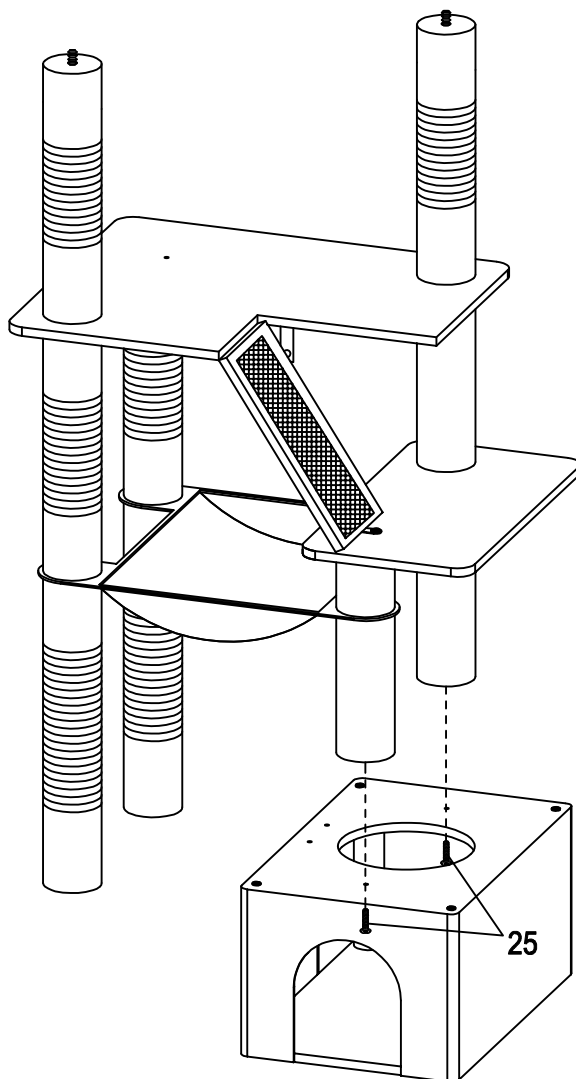
**Step 7**

- Assemble lower scratching board 13.6"(34.5cm) length(#14) with connecting bracket(#31) and flathead screw, M8\*15mm(#27).

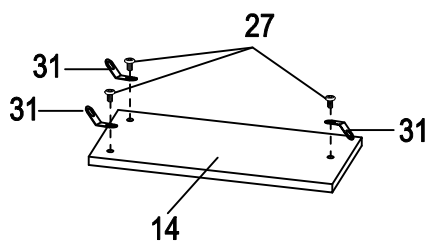

**Step 8**

- Assemble boards(#11 & #10) and posts(#18 & #17) with thread rod,M8\*80mm(#28) and flathead screw,M8\*28mm(#26). Attach the assembled units to the bottom plate(#8) with flathead screw,M8\*40mm(#25).

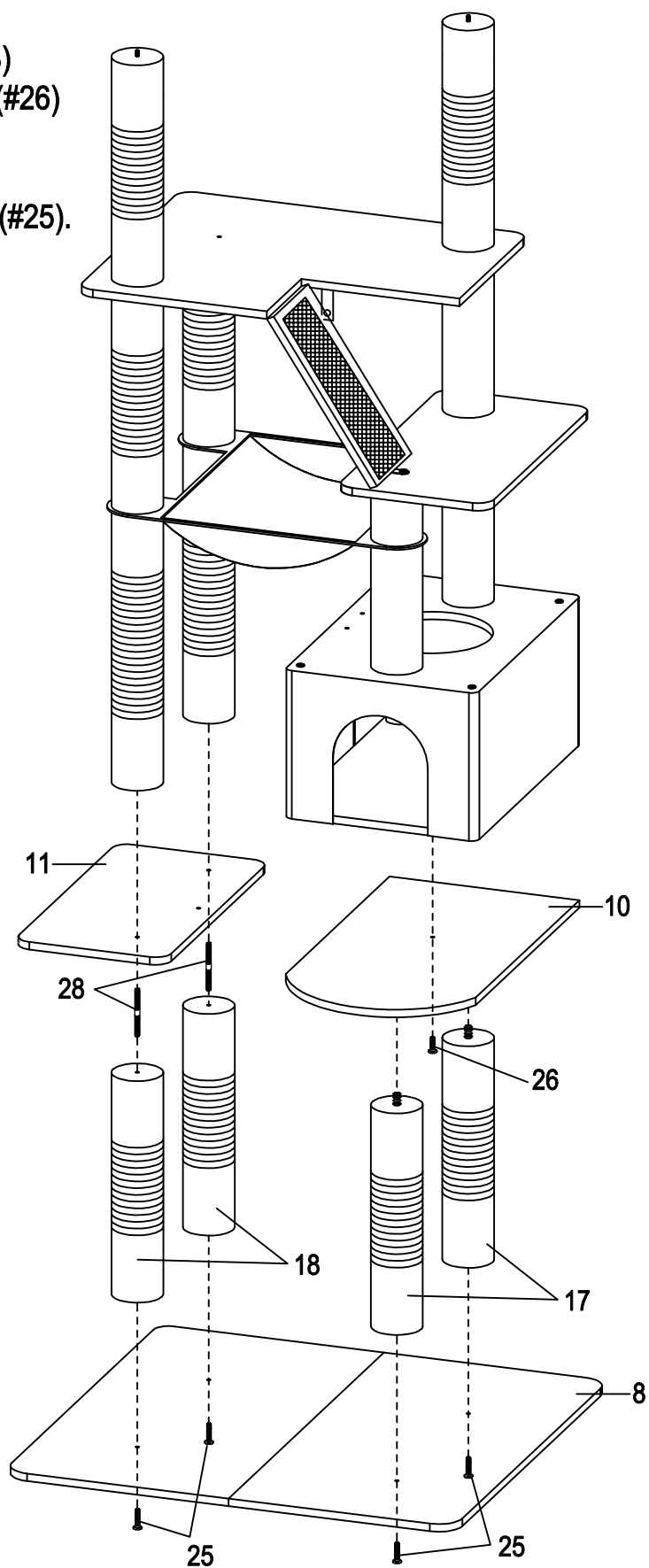

**Step 9**

- Attach lower scratching board 13.6"(34.5cm) length(#14) to the lying plates(#11) and rectangle cave with flathead screw, M8\*15mm(#27).

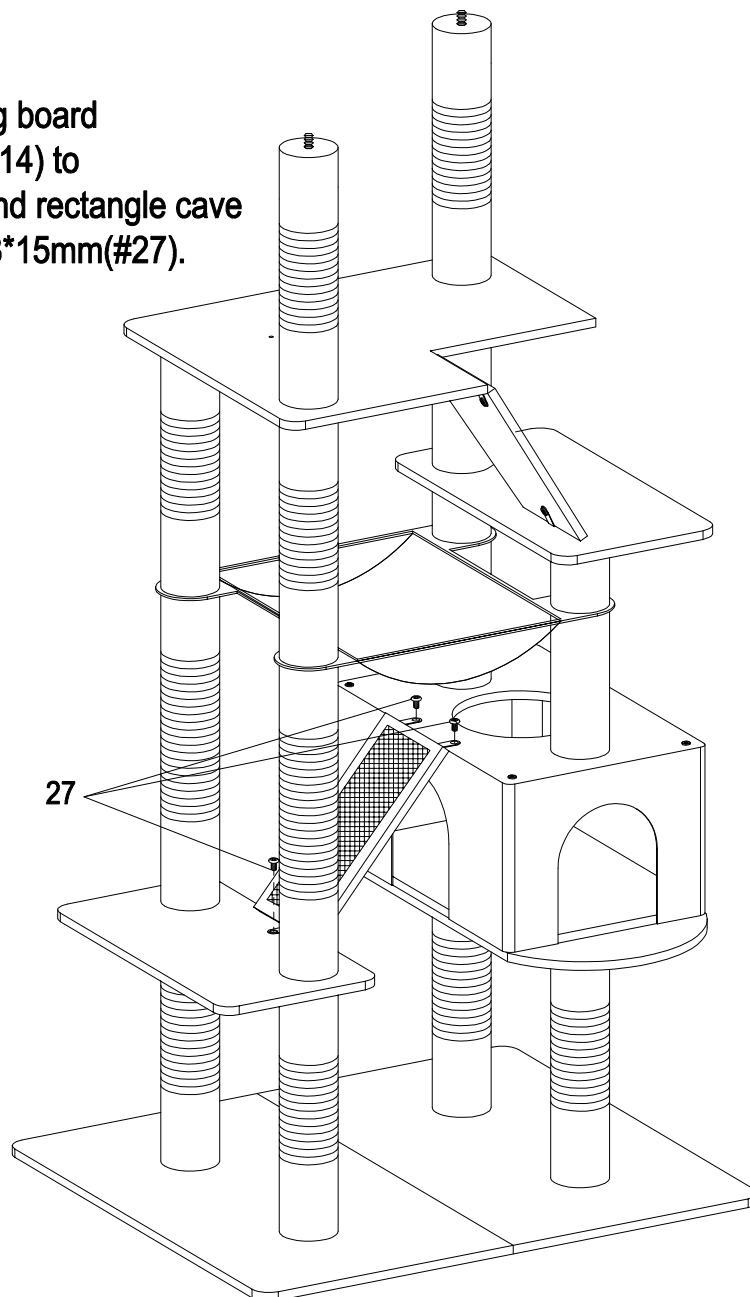
**Step 10**

- Assemble the boards(#4 & #5) with posts(#24) and square cave cover(#3) with flathead screw, M8\*40mm(#25). Make sure the edge of cover is well under bottom board(#7).

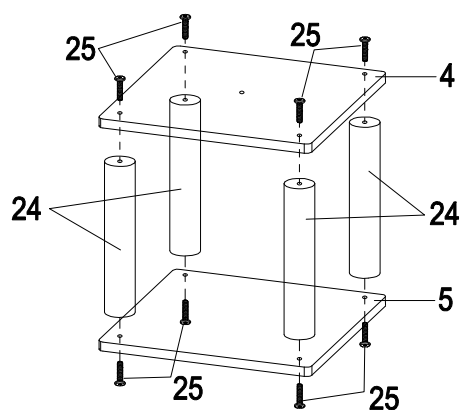
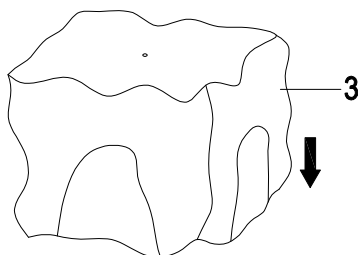

**Step 11**

- Attach the square cave to the lying plates(#9) with flathead screw, M8\*28mm(#26), and assemble square beds(#1 & #2) and posts(#17) with washer(#32) and flathead screw, M8\*40mm(#25).

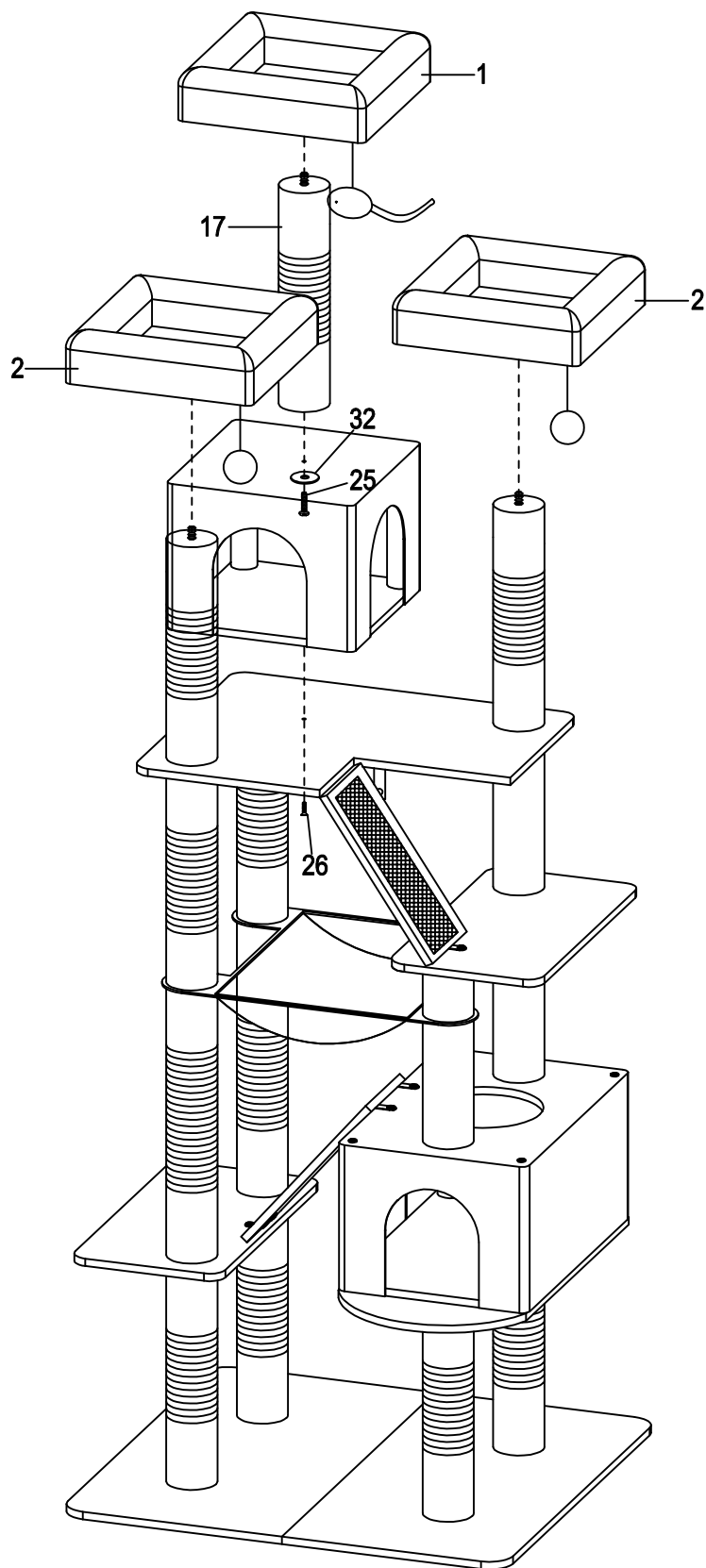

**Step 12**

- Attach this product to the wall with wall plug(#30) and tapping rod,M4\*48mm(#29). Before you drill a hole in the wall, make sure there are no pipes or electric cables in the place you want to drill.

