

INSTRUCTION MANUAL

GUT02

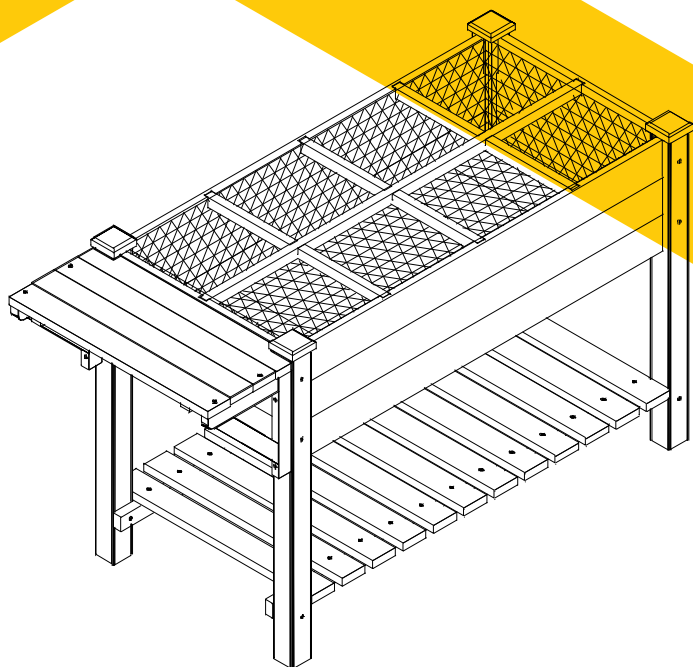

aivituvin

www.aivituvin.com



NOTICE

Please retain these instructions for future reference.

- Firmly secure all bolts,screws and knobs before use.
- Reconfirm that all bolts,screws,and knobs are secure every 90 days.
- Fasten screws loosely during initial assembly. Do not fully tighten screws until the item is completely assembled.
- Do not use or store this item in the proximity of open flame or flammable/combustible chemicals.
- Be aware that some parts are heavy and have sharp edges.
- Be aware that moving parts can injure,crush and cut.
- If any parts are missing,broken,damaged,or worn,stop using this product until repairs are made and/or factory replacement parts are installed.
- Do not use this item in a way inconsistent with the manufacturer' s instructions as this could void the product warranty.

TOOLS REQUIRED



PHILLIPS
SCREWDRIVER

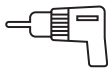

DRILL
(RECOMMENDED)



2PERSON
ASSEMBLY



APPROXIMATELY
30MIN. ASSEMBLY

HARDWARE

M6.0x90mm SCREW
4PCS spare



P1

M3.5x60mm SCREW
20PCS+1 spare

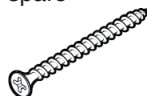

P2

M3.5x35mm SCREW
36PCS+1spare



P3

PARTS

Leg A
2 PCS

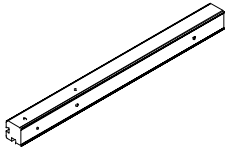

A

Leg B
2 PCS

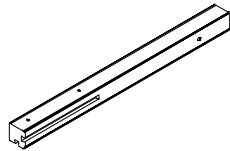

B

Short panel
4 PCS

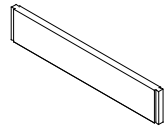

C

Short panel with slot
2 PCS

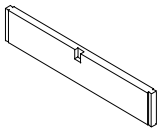

D

Long panel with slot
2 PCS

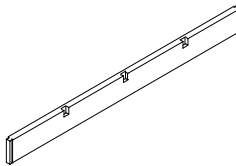

E

Long panel-Second level
2 PCS

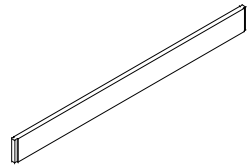

F

Long panel-Bottom level
2 PCS

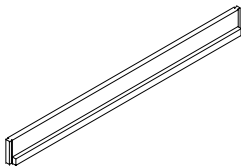

G

Bottom panel H
1 PC

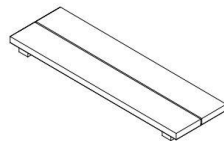

H

Bottom panel I
2 PCS

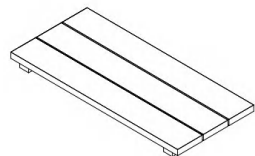

I

PARTS

Bottom panel J
2 PCS

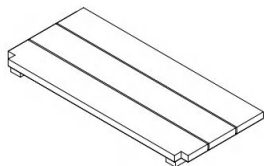

J

Supporting panel K
2 PCS

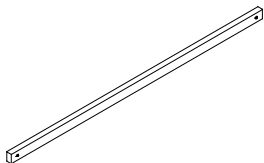

K

Base panel
12 PCS

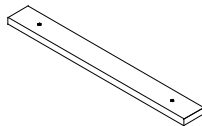

L

Supporting for side table
2 PCS

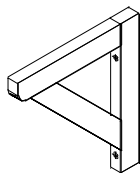

M

Side table panel
1 PC

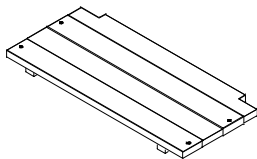

N

Divider O
3 PCS

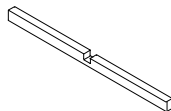

O

Divider P
1 PC

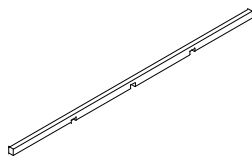

P

Leg end
4 PCS

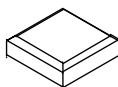

Q

Inner lining
1 PC

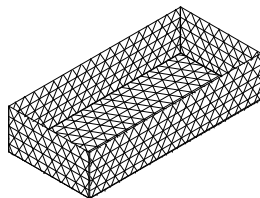

R

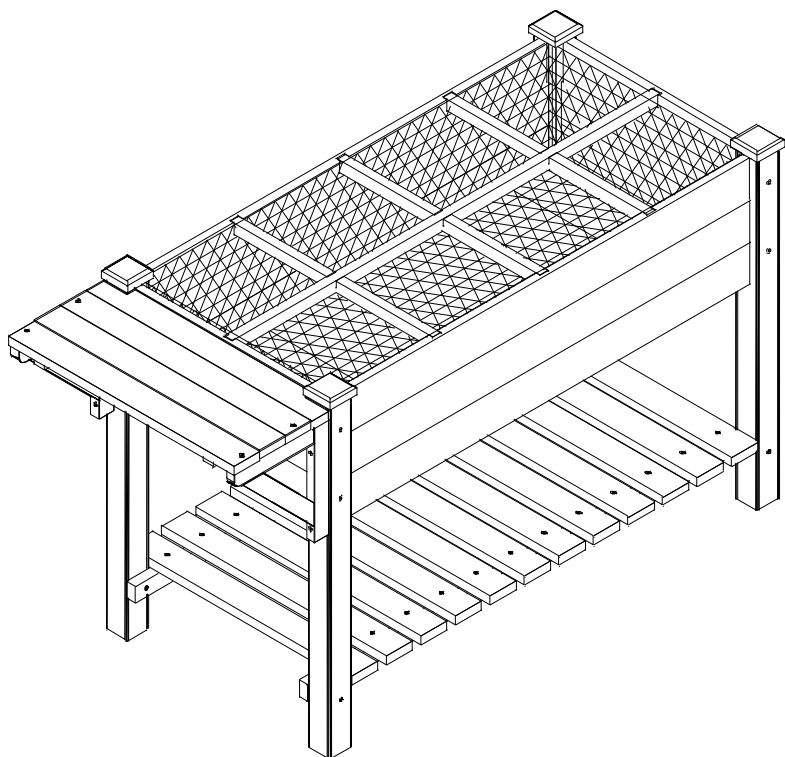

PRODUCT ASSEMBLY //

01

Slide two Part C and one Part D short panels into Part A & Part B legs
Secure panels with P2X4.

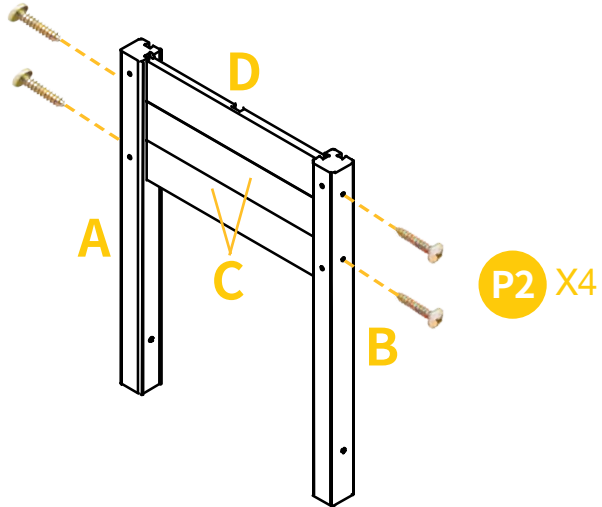

02

Repeat to build another set of legs.

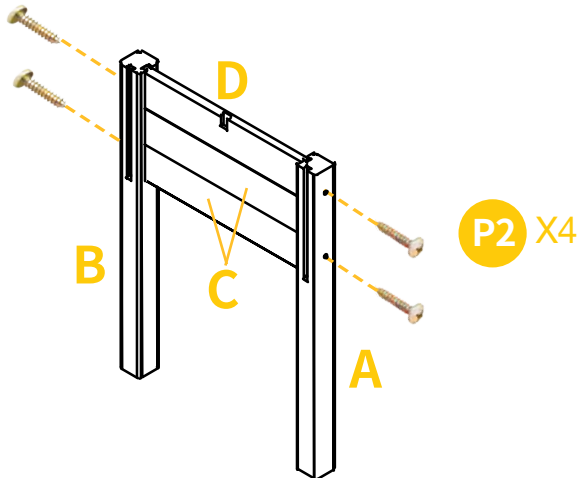

PRODUCT ASSEMBLY //

- 03** Slide a Part G, Part F, Part E orderly into the legs. Secure panels with P2X4.

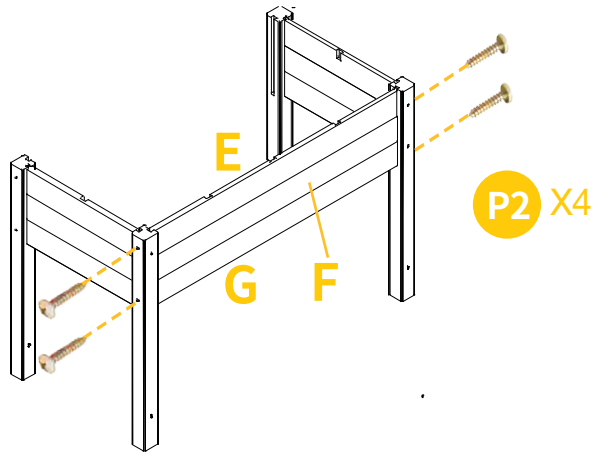

- 04** Repeat on the other side.

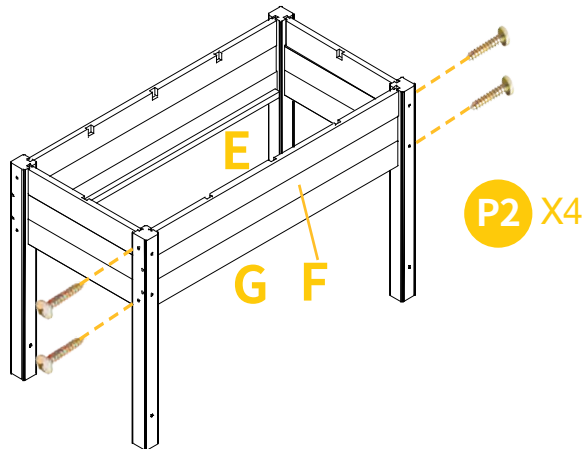

PRODUCT ASSEMBLY //

05

Insert two Part J and one Part H, two Part I bottom panels.

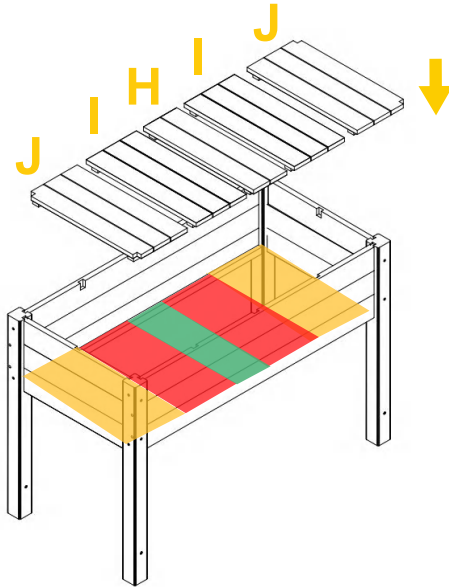

06

Attach Part K to legs with bolt P1X2

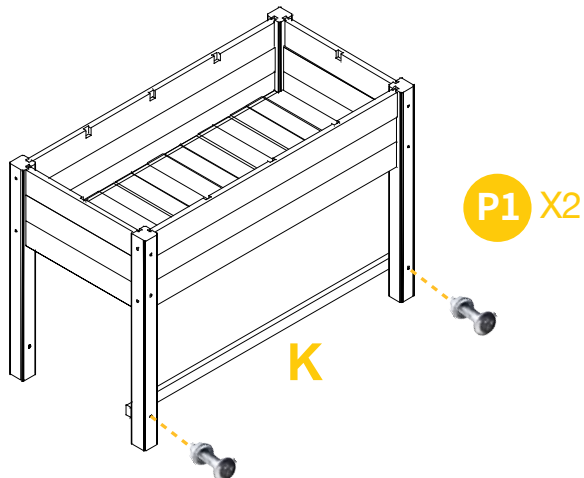

PRODUCT ASSEMBLY //

07 Repeat on the other side.

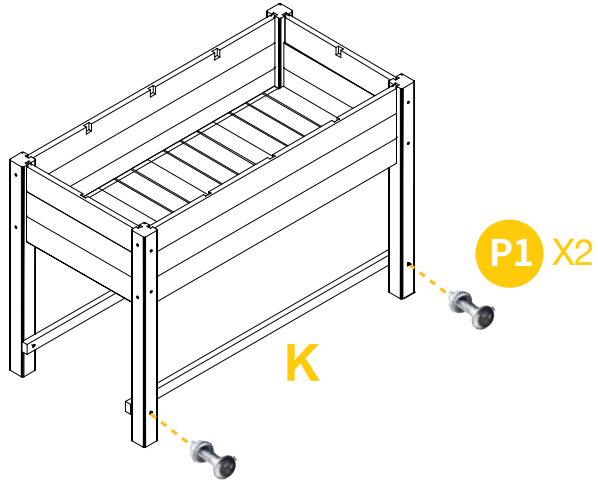

08 Attach Part L to Part K with P3X12.

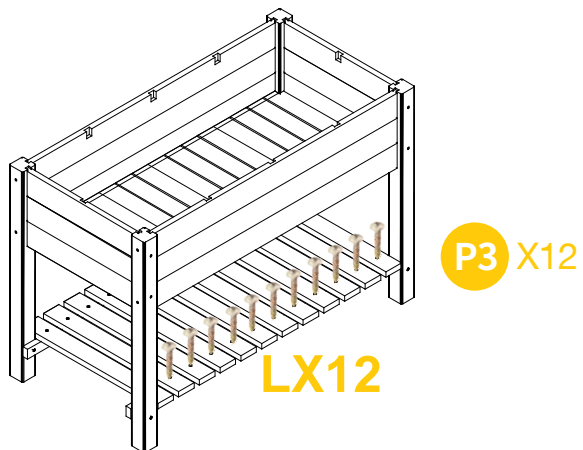

PRODUCT ASSEMBLY //

09

Screw P3X12 on the other side.

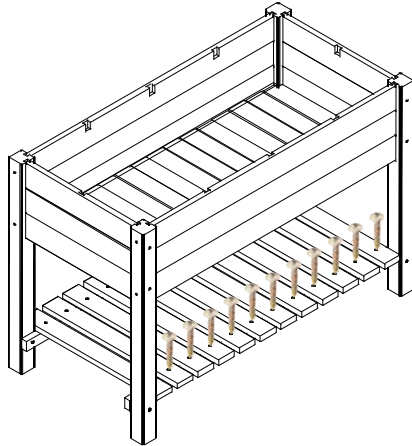

P3 X12

10

Insert the Part R inner lining.

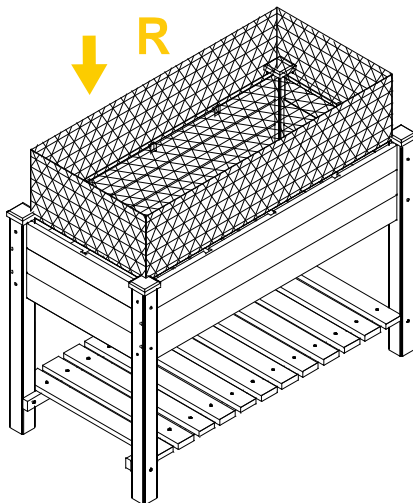

PRODUCT ASSEMBLY //

- 11** Stuck in divider one Part P and three Part O into the slots.

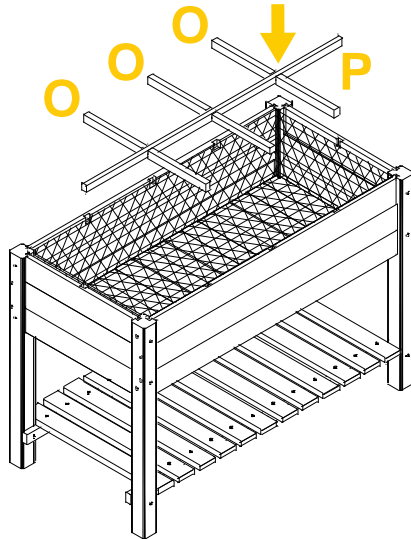

- 12** Attach two Part M to with P2X4.
【The side table can be assemble on left/right side either. Both pre-drilled are included !】

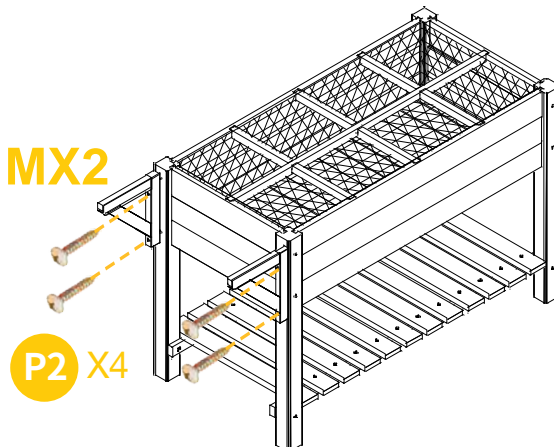

PRODUCT ASSEMBLY //

- 13** ① Attach Part N to the Part M with P3X4.
② 【 The side table can be assemble on left/right side either. Both pre-dilled holes are included! 】

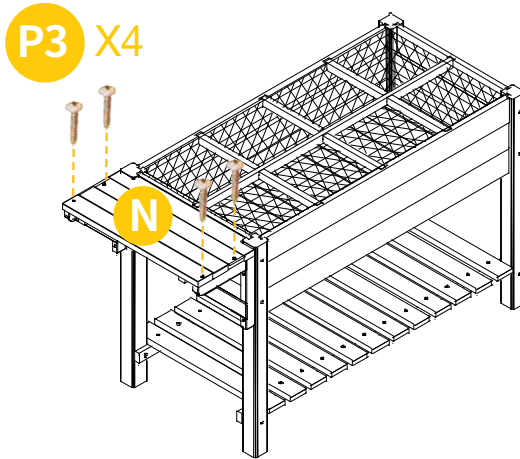

- 14** Attach four Part Q leg ends with P3X8.

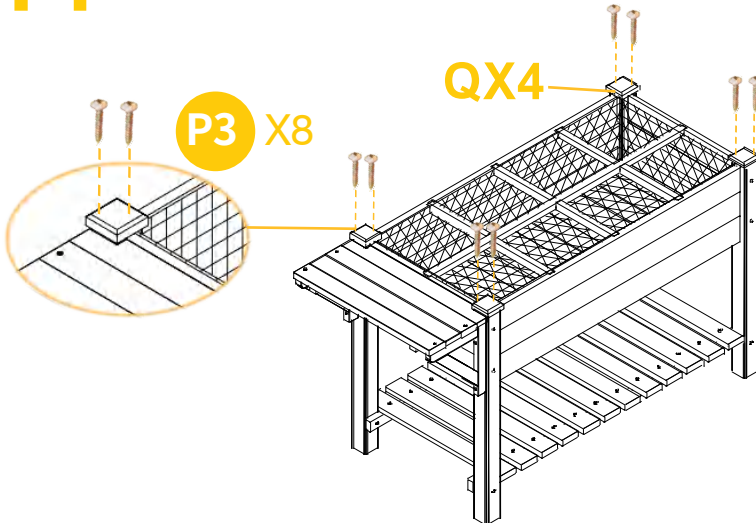



WARNING

Manufacturer and seller expressly disclaim any and all liability for personal injury, property damage or loss, whether direct, indirect, or incidental, resulting from the incorrect attachment, improper use, inadequate maintenance, or neglect of this product.