

# INSTRUCTION MANUAL

AIR 59

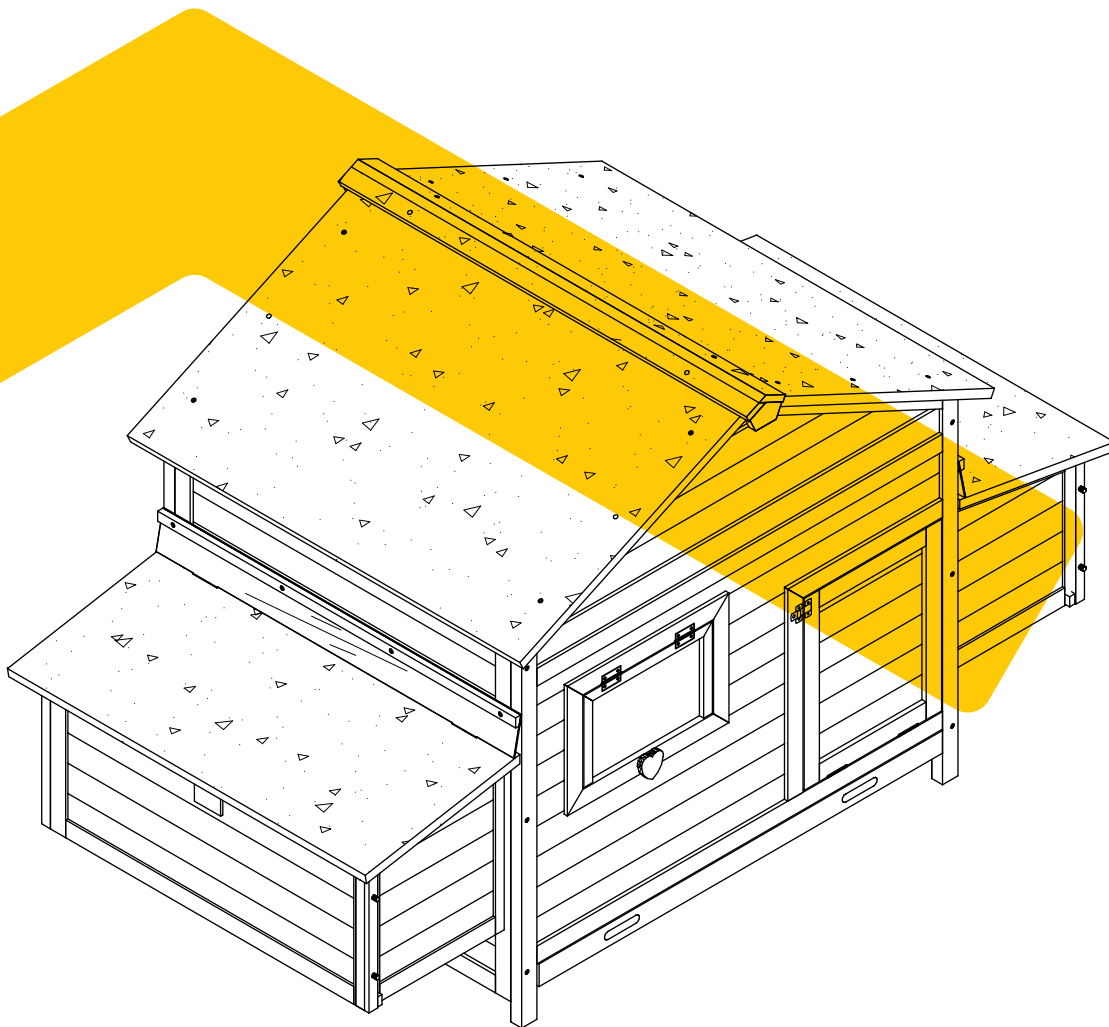



## NOTICE

Please retain these instructions for future

- Firmly secure all bolts, screws and knobs before use.
- Reconfirm that all bolts, screws, and knobs are secure every 90 days.
- Fasten screws loosely during initial assembly. Do not fully tighten screws until the item is completely assembled.
- Do not use or store this item in the proximity of open flame or flammable/combustible chemicals.
- Be aware that some parts are heavy and have sharp edges.
- Be aware that moving parts can injure, crush and cut.
- If any parts are missing, broken, damaged, or worn, stop using this product until repairs are made and/or factory replacement parts are installed.
- Do not use this item in a way inconsistent with the manufacturer's instructions as this could void the product warranty.

# TOOLS REQUIRED



PHILLIPS  
SCREWDRIVER

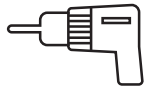

DRILL  
(RECOMMENDED)



2PERSON  
ASSEMBLY



APPROXIMATELY  
60MIN. ASSEMBLY

# HARDWARE

M6.0x55 mm BOLT  
8PCS+1 spare



P1

M3.5x60 mm SCREW  
20PCS+1 spare



P2

M3.5x40 mm SCREW  
16PCS+1 spare



P3

M3.5x35 mm SCREW  
12PCS+1 spare



P4

M3.5x25 mm SCREW  
8PCS+1 spare



P5

M3.0x16 mm SCREW  
6PCS+1 spare



P6

Lock  
1PC

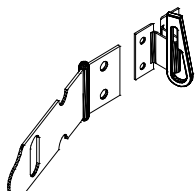

P7

M3.0x12 mm SCREW  
2PCS+1 spare



P8

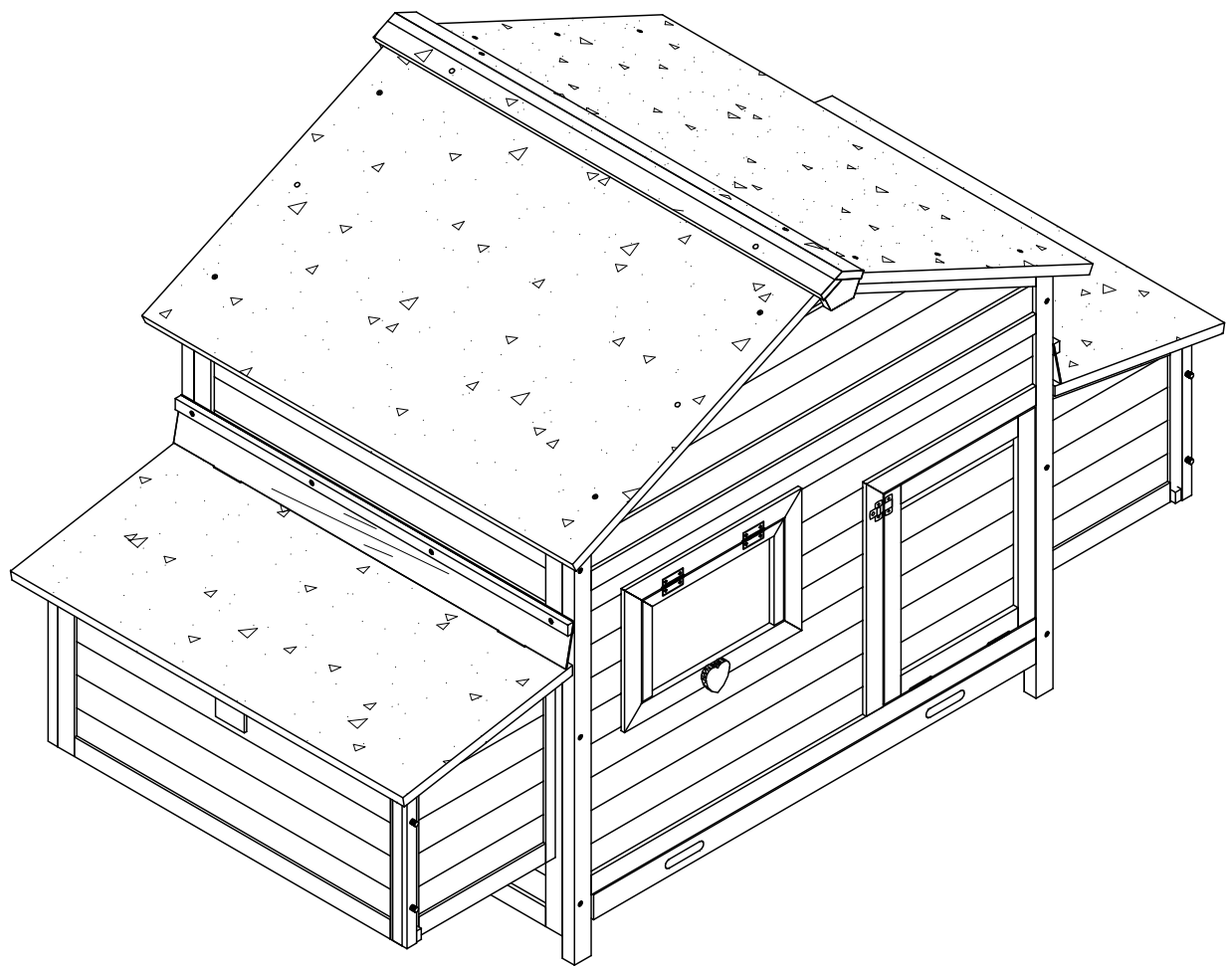

# PARTS

Upper panel-front and back  
2PCS

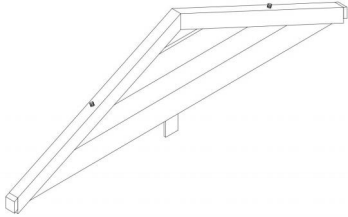

**A**

Side panel  
2PCS

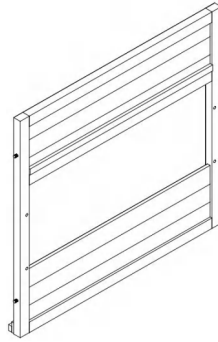

**B**

Tray  
1PC

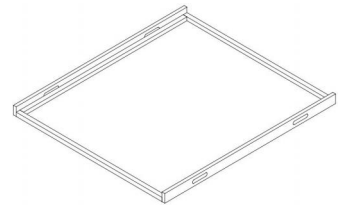

**C**

Perch  
3PCS

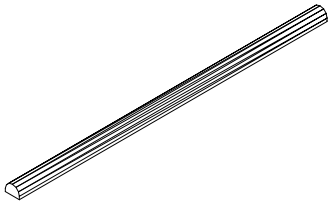

**D**

Side panel of nesting box  
2PCS

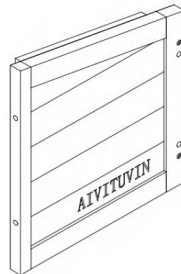

**E**

Side panel of nesting box  
2PCS

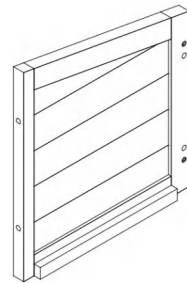

**F**

Front panel of nesting box  
2PCS

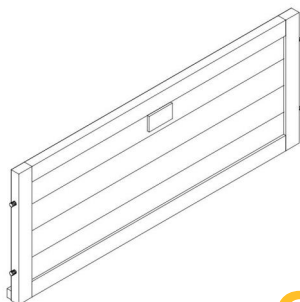

**G**

Bottom of nesting box  
2PCS

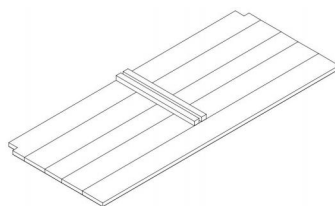

**H**

Divider  
2PCS

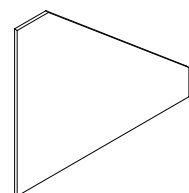

**I**

# PARTS

Roof of nesting box  
2PCS

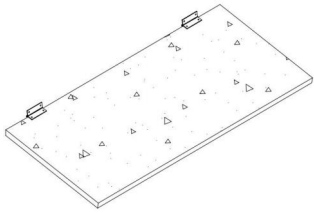

J

Roof  
2PCS

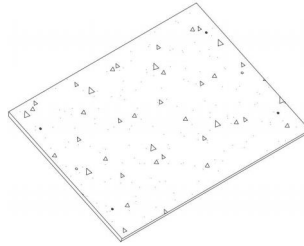

K

PVC Waterproof Strip  
2PCS

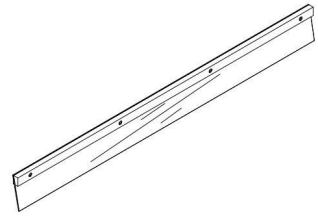

L

Roof cap  
2PCS

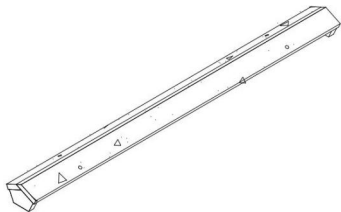

M

Down panel- front and back  
2PCS

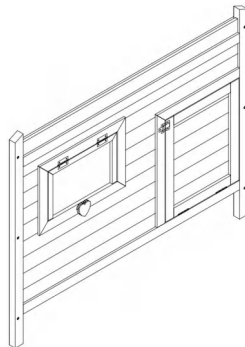

N

# PRODUCT ASSEMBLY

**01** Attach Part A & N to the side panel Part B by 16XP2 screws, then connect the Part A & N by 2XP8 screws.

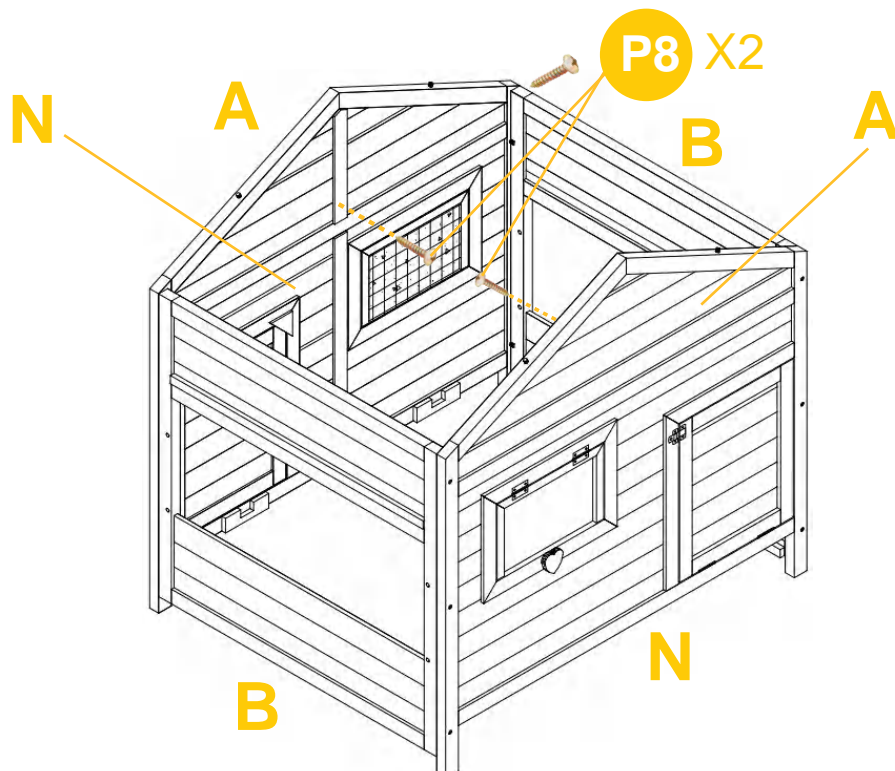
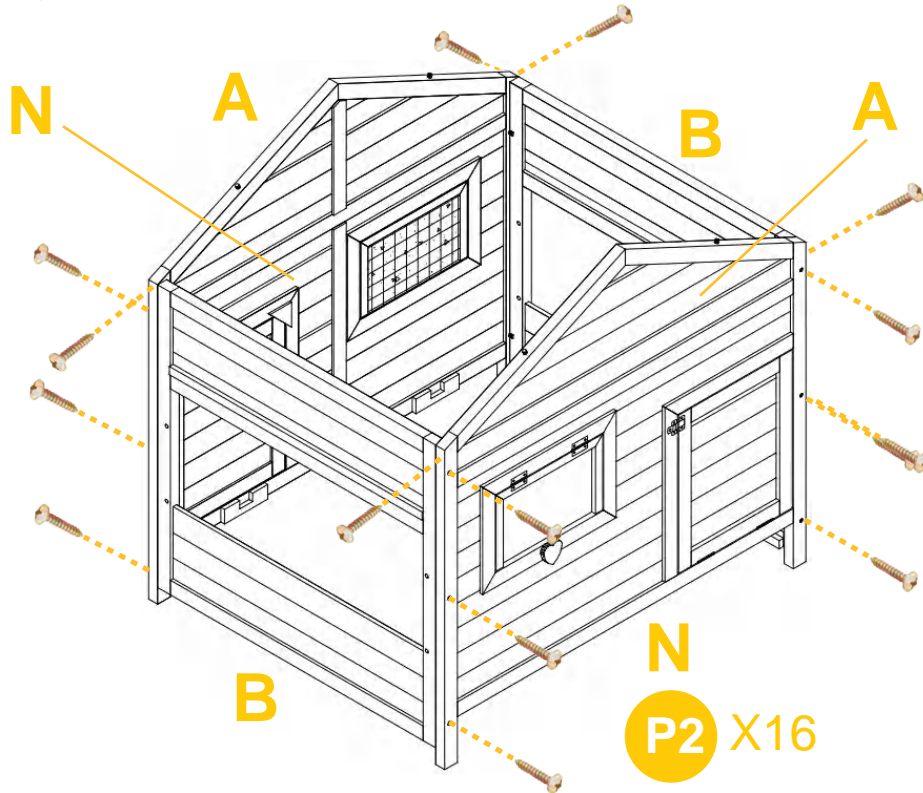

## PRODUCT ASSEMBLY

**02** Slide in the metal tray Part C.

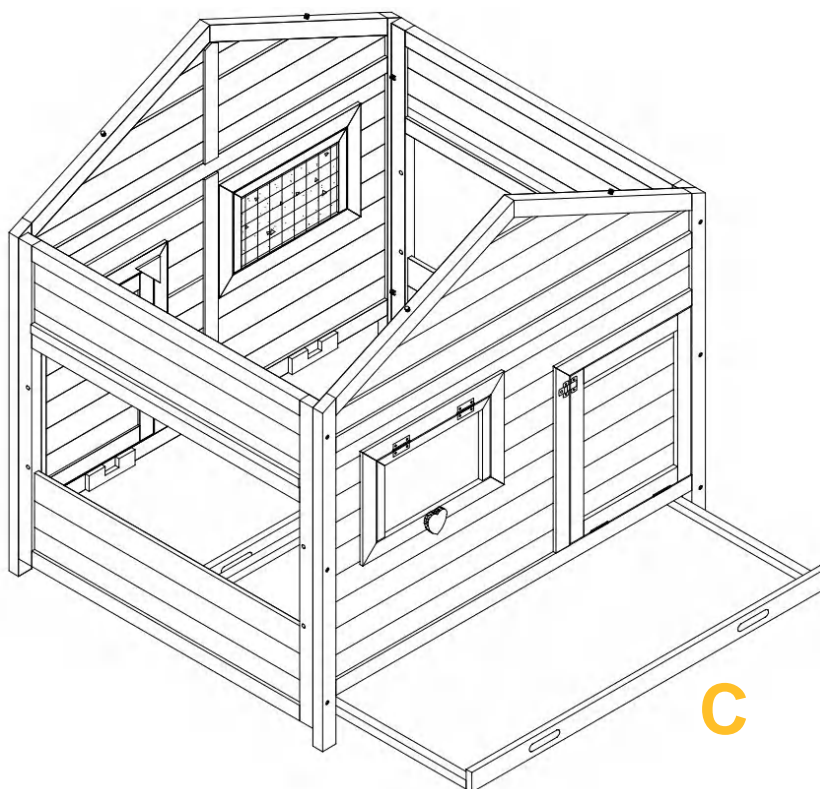

**03** Insert the perches 3xPart D into the slots inside the front and back panel of coop.

**Dx3**

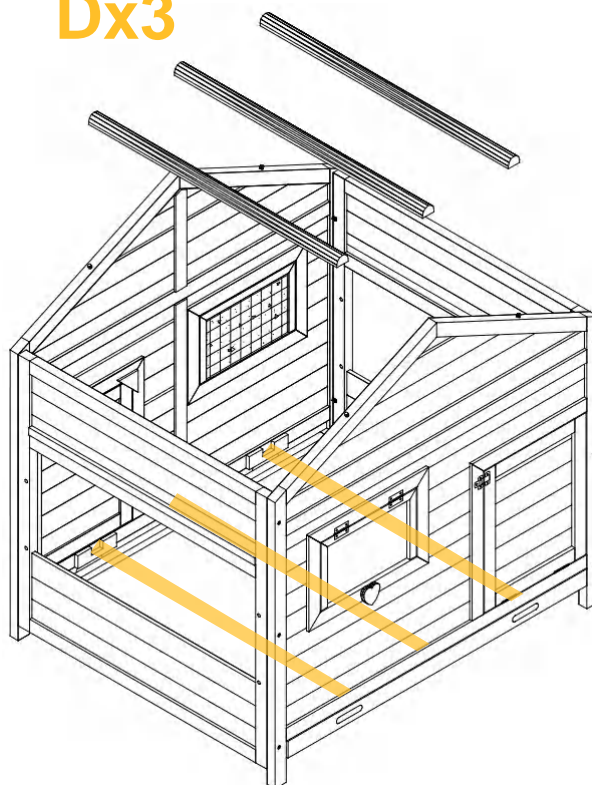



## PRODUCT ASSEMBLY

**04** Attach the side panels of nesting box Part E & F to the left side of coop by bolt 4xP1.

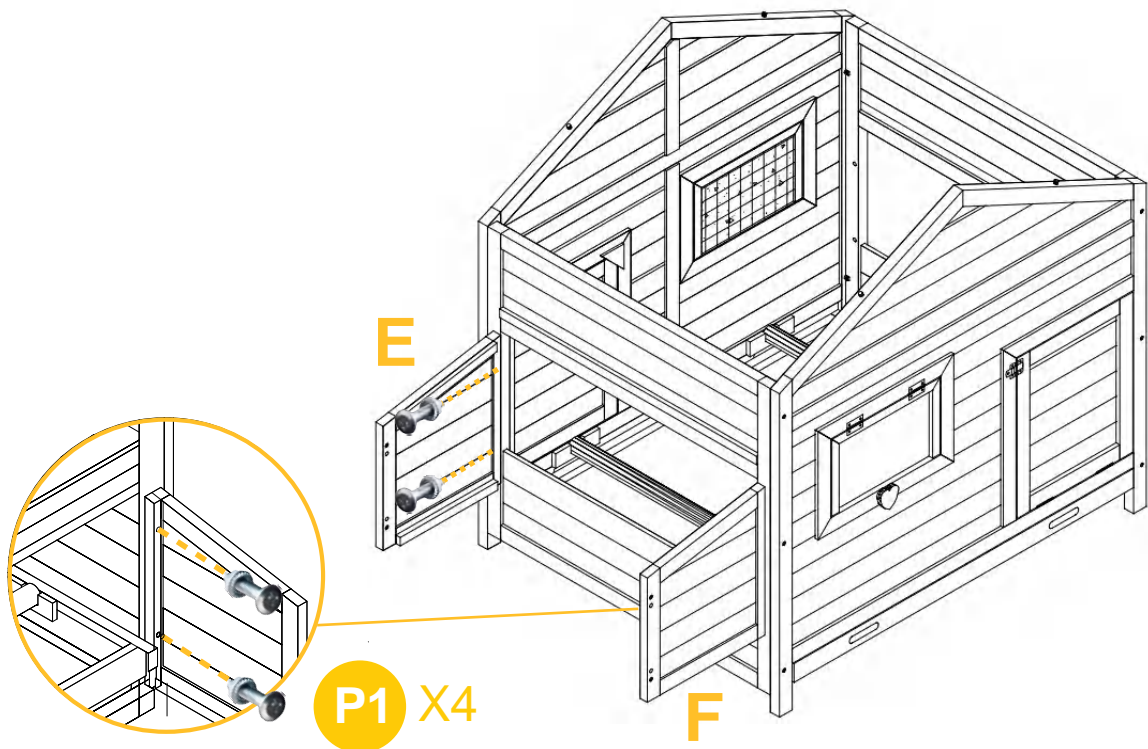

**05** Attach the side panels of nesting box Part E & F to the right side of coop by bolt 4xP1.

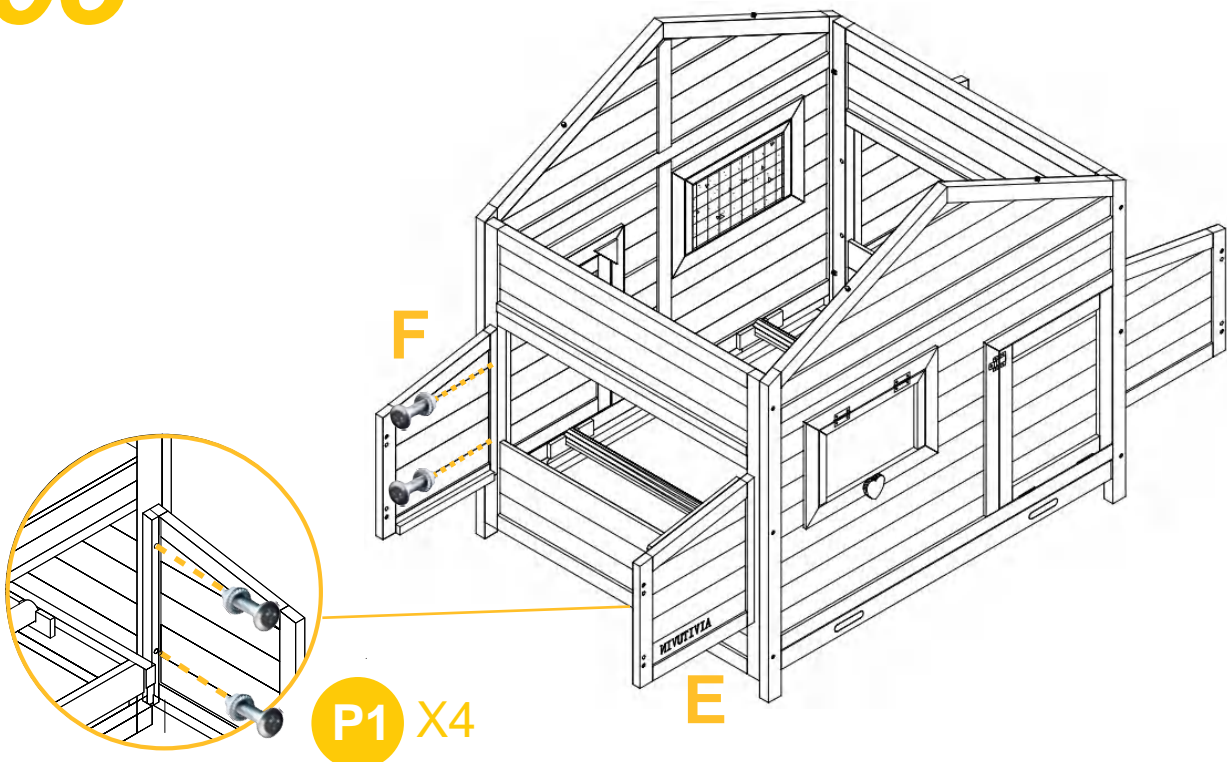

## PRODUCT ASSEMBLY

**06** Attached the front panel of nesting box Part G by 4xP3 screws each side. .

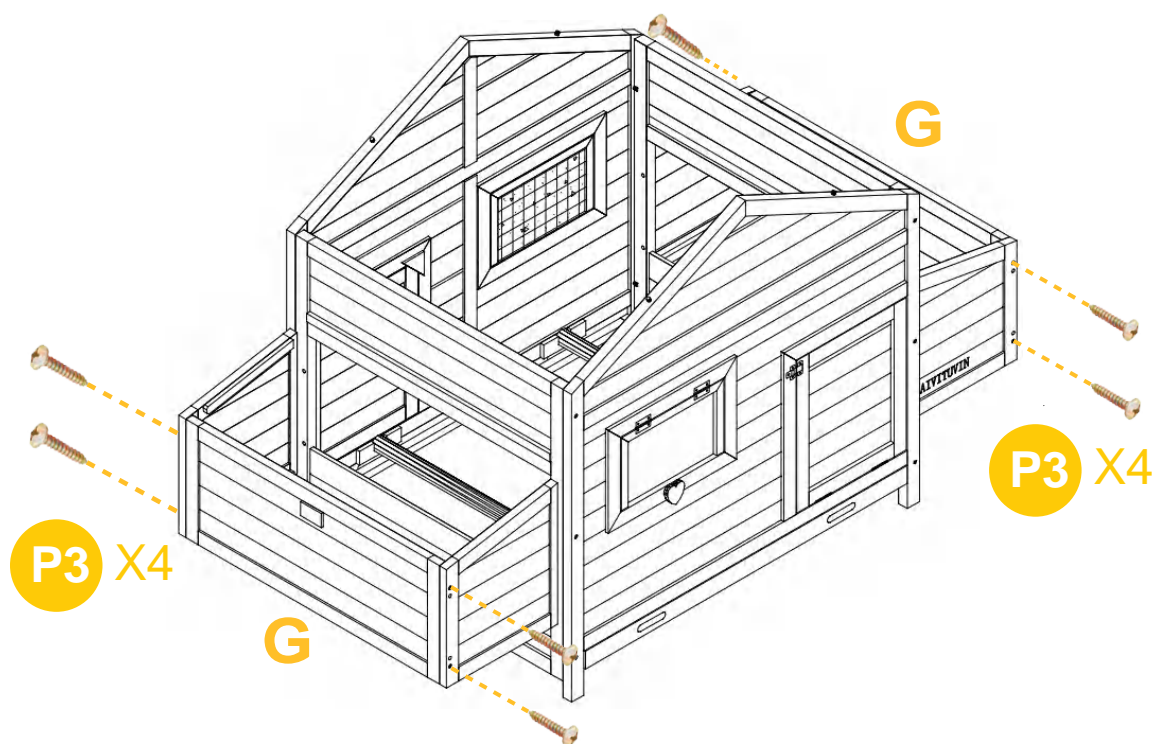

**07** Drop in the bottom panel of nesting box Part H.  
Slide in the divider Part I each side.

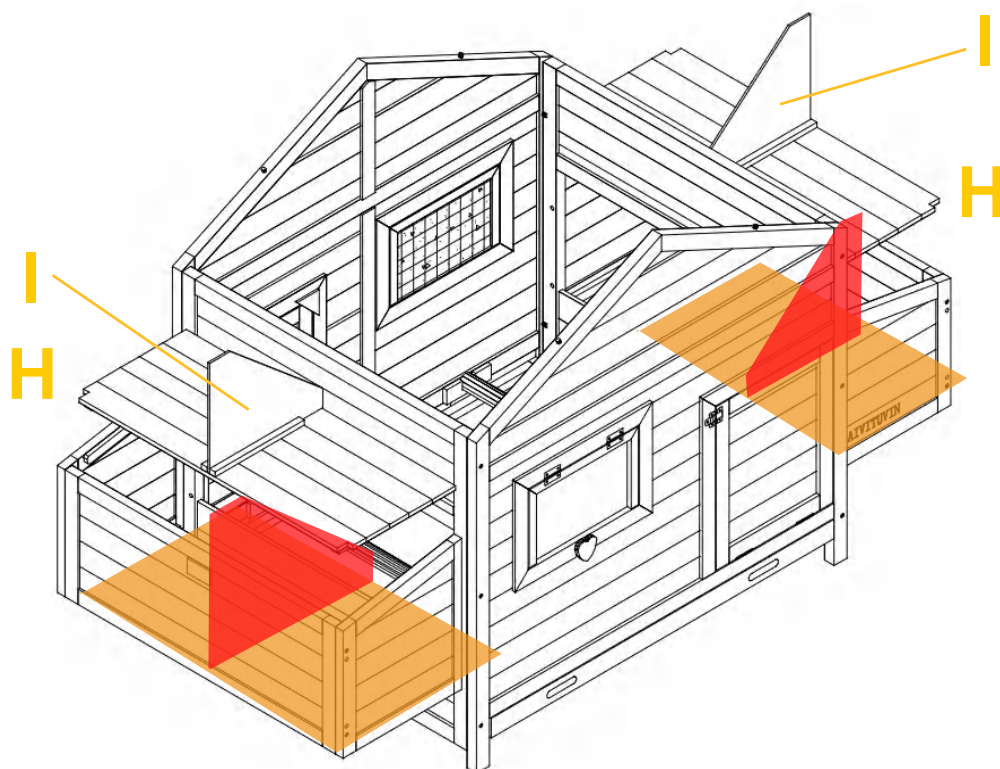

## PRODUCT ASSEMBLY

- 08** Attach the roof of nesting box 2xPart J to the nesting box by 4XP5 screws each side. Make sure the lock is functioning properly before locking the roof.

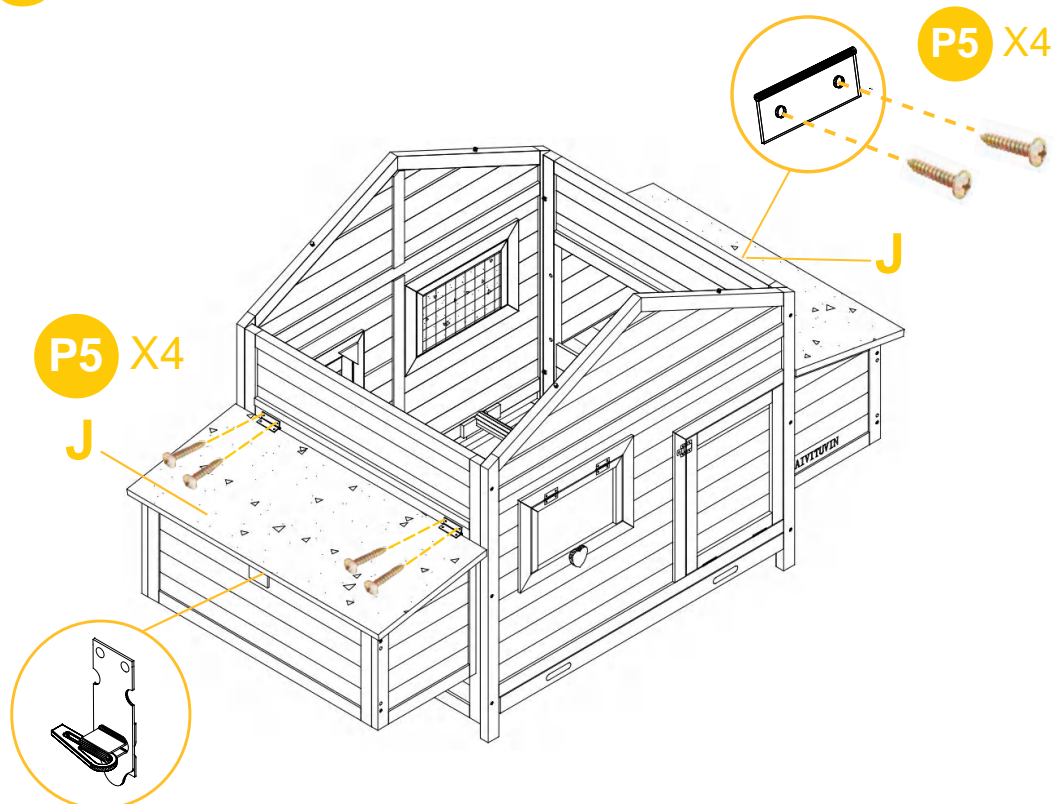

- 09** Attach the coop roof 2xPart K to the coop by 8XP3 screws.

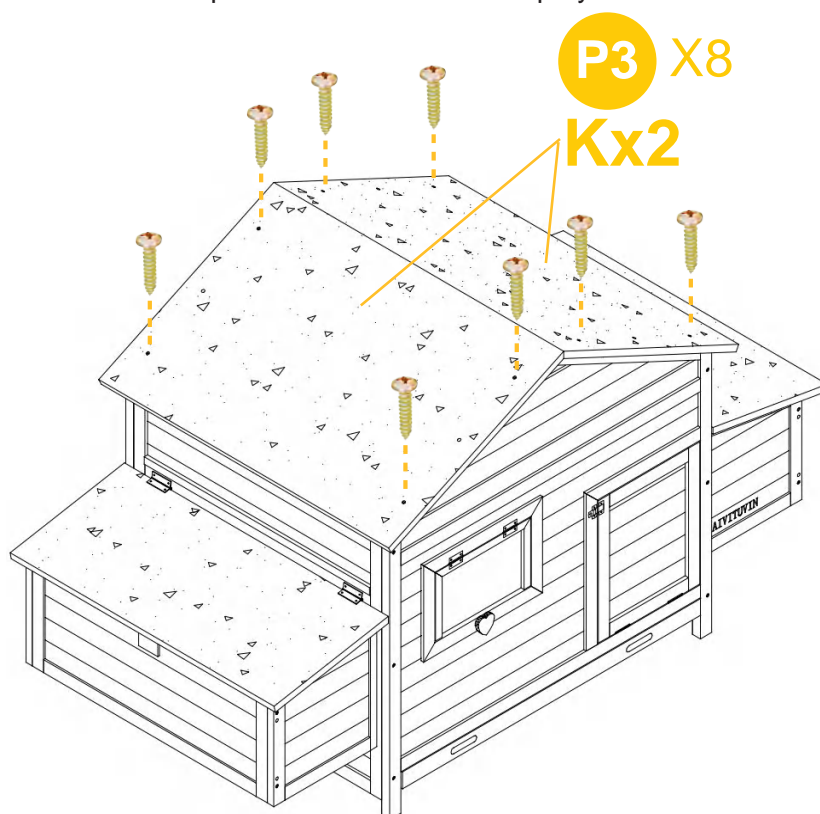



## PRODUCT ASSEMBLY

- 11** Attach the roof cap Part M by 4XP4 screws.  
Attach lock P7 to the tray by 6xP6.

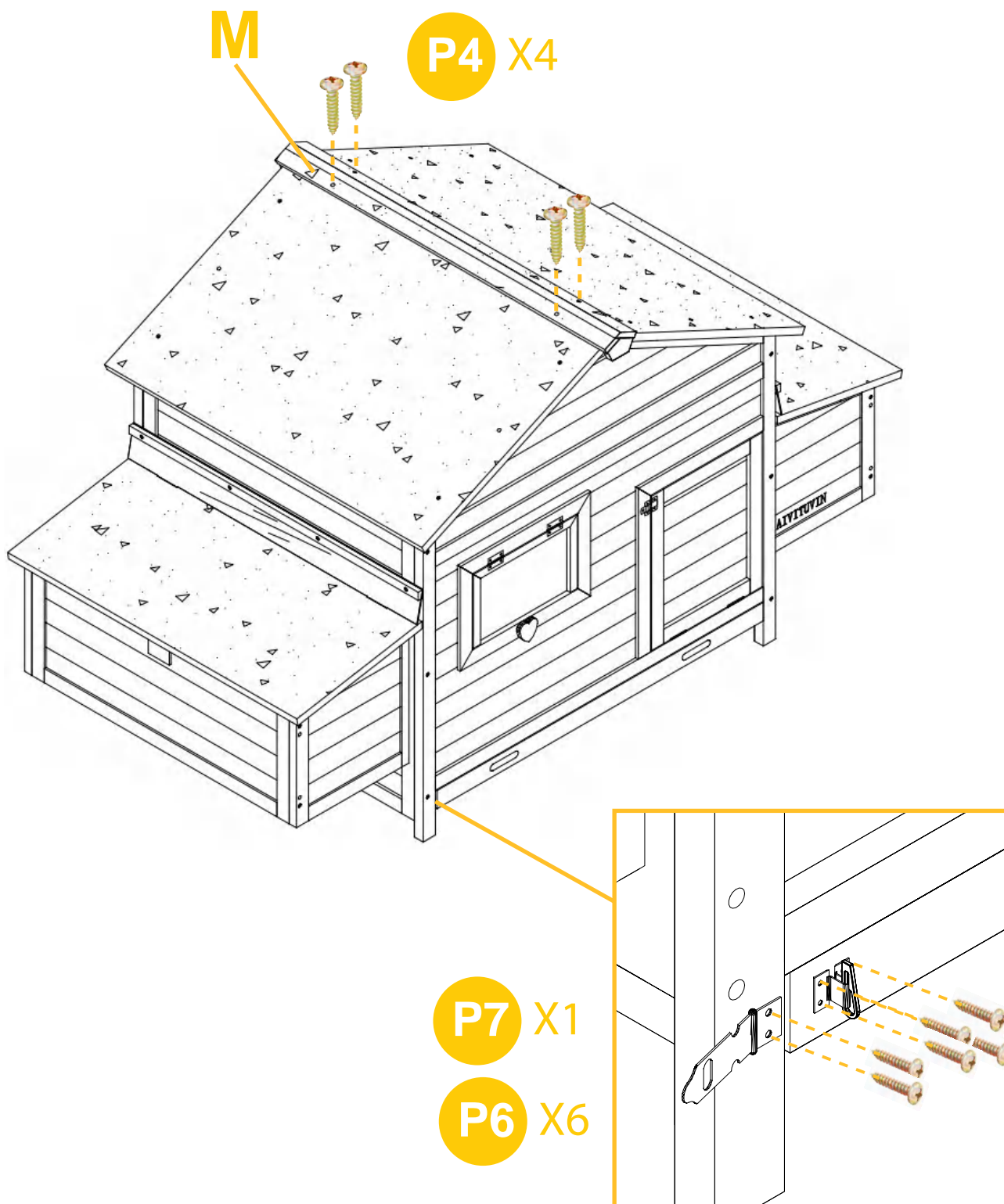

# Notice

Read Before Assemble!

Pls ignore the following for only one coop owner !

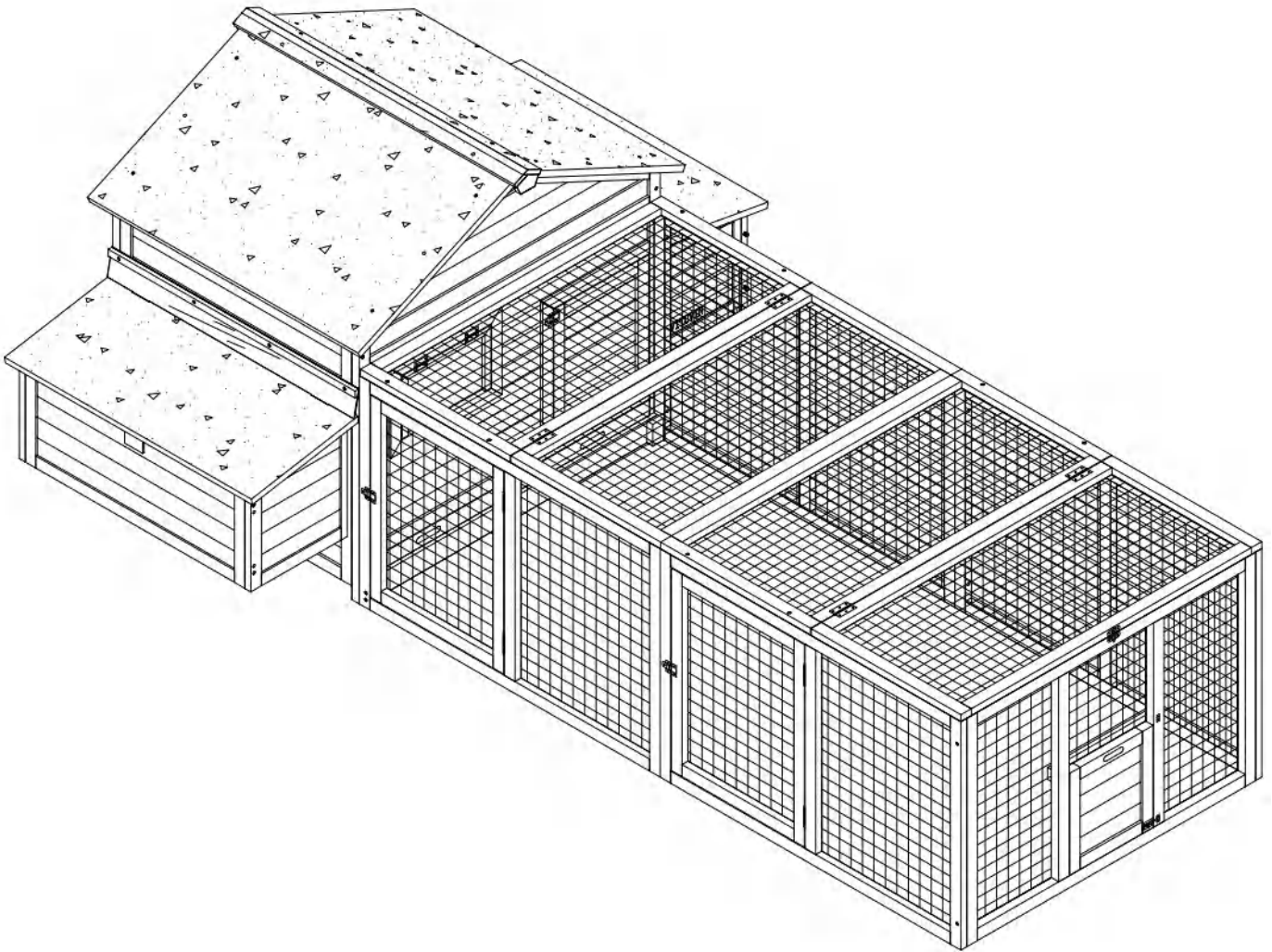

## PRODUCT ASSEMBLY

**12** Attach the run to the coop by 2xP2 screws.

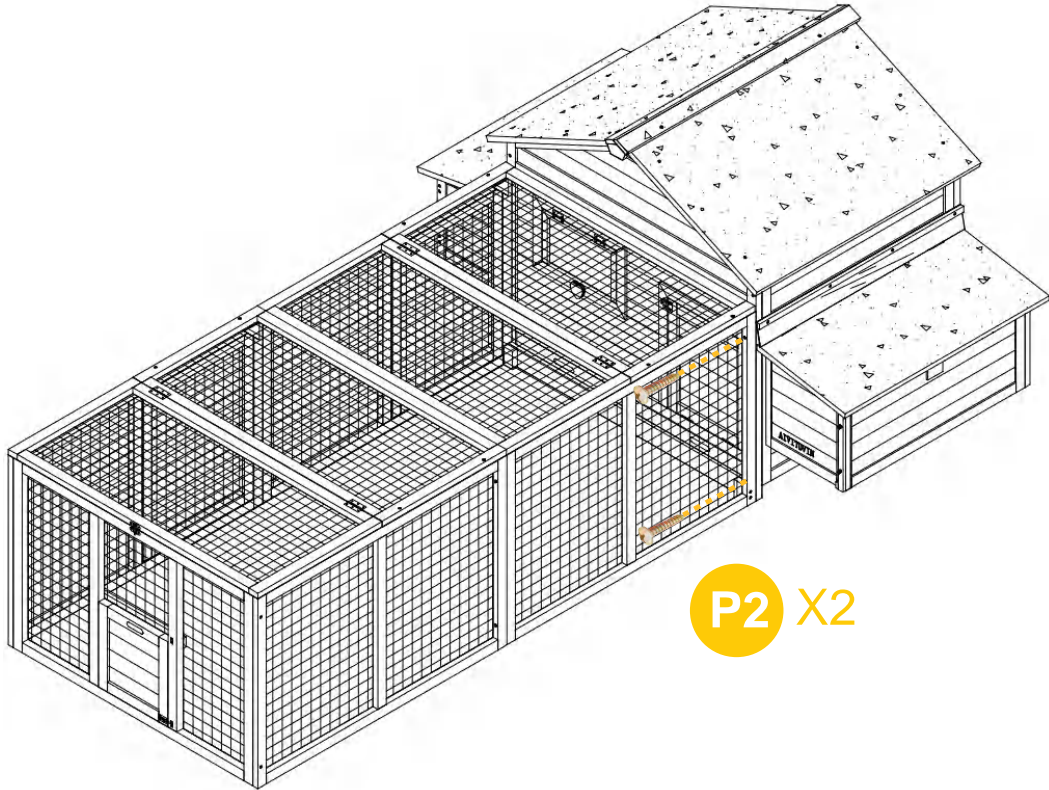

**P2 X2**

**13** Attach the run to the coop by 2xP2 screws.

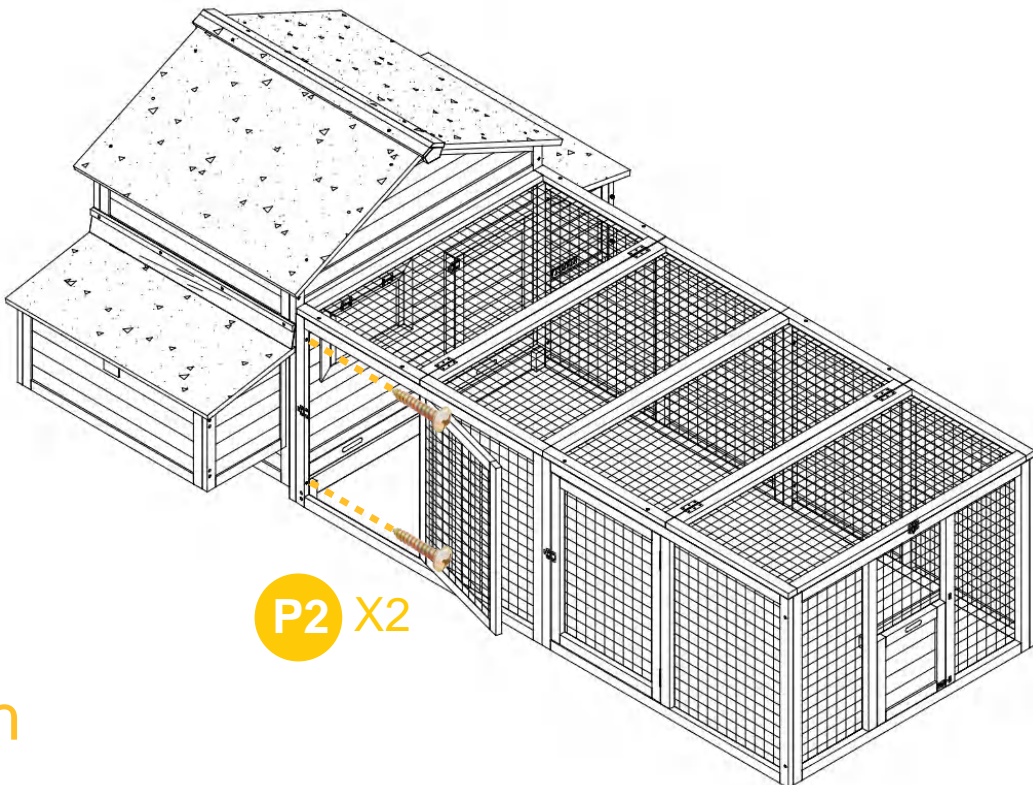

**P2 X2**

Finish



**WARNING**

Manufacturer and seller expressly disclaim any and all liability for personal injury, property damage or loss, whether direct, indirect, or incidental, resulting from the incorrect attachment, improper use, inadequate maintenance, or neglect of this