

# INSTRUCTION MANUAL

AIR 55

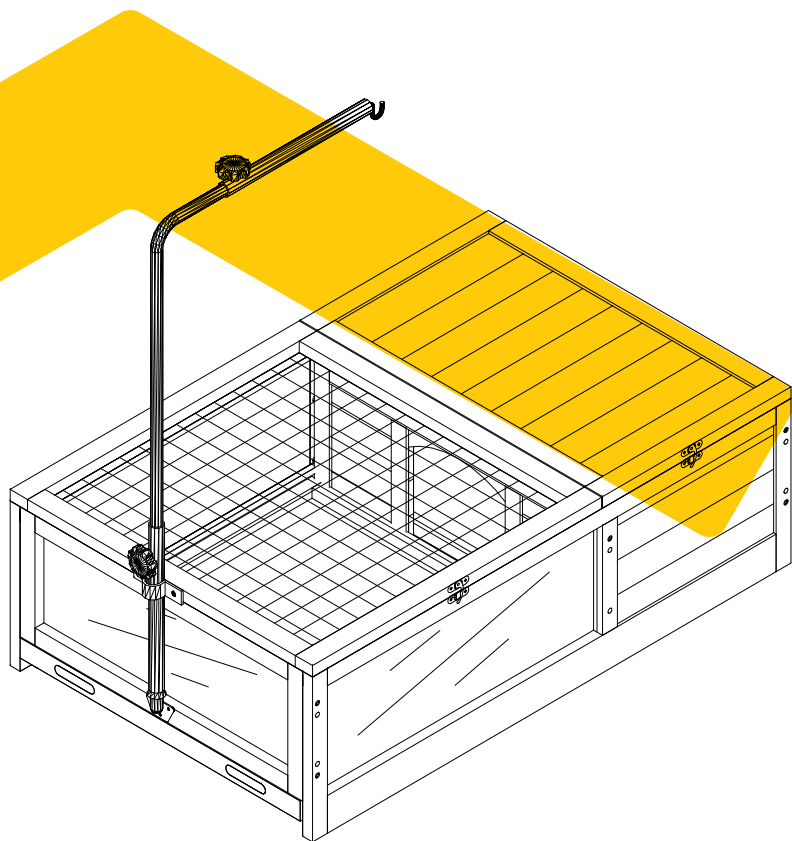

aivituvin

[www.aivituvin.com](http://www.aivituvin.com)





## NOTICE

Please retain these instructions for future reference.

- Firmly secure all bolts,screws and knobs before use.
- Reconfirm that all bolts,screws,and knobs are secure every 90 days.
- Fasten screws loosely during initial assembly. Do not fully tighten screws until the item is completely assembled.
- Do not use or store this item in the proximity of open flame or flammable/combustible chemicals.
- Be aware that some parts are heavy and have sharp edges.
- Be aware that moving parts can injure,crush and cut.
- If any parts are missing,broken,damaged,or worn,stop using this product until repairs are made and/or factory replacement parts are installed.
- Do not use this item in a way inconsistent with the manufacturer' s instructions as this could void the product warranty.

## TOOLS REQUIRED //



PHILLIPS  
SCREWDRIVER

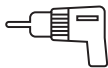

DRILL  
(RECOMMENDED)



2PERSON  
ASSEMBLY



APPROXIMATELY  
45MIN. ASSEMBLY

## HARDWARE //

M3.5x40mm SCREW  
12PCS+1 spare



P1

M3.0x16mm SCREW  
21PCS+1 spare



P2

Latch  
2PCS



P3

Plastic bottom  
1PC

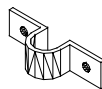

P4

Plastic pipe  
1PC



P5

# PARTS //

Front panel  
1PC

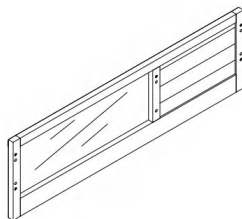

**A**

Back panel  
1PC

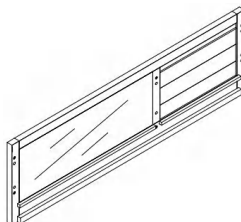

**B**

Left panel  
1PC

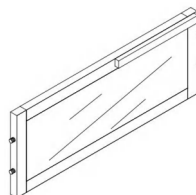

**C**

Right panel  
1PC

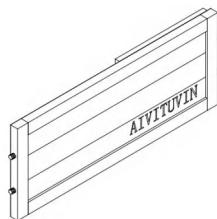

**D**

Divider  
1PC

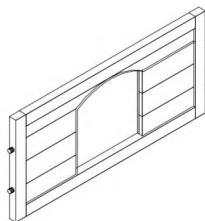

**E**

Left tray  
1PC

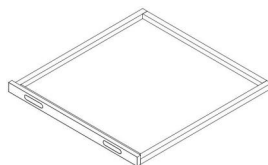

**F**

Right tray  
1PC

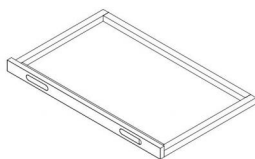

**G**

Wooden roof  
1PC

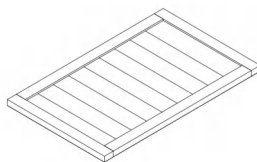

**H**

Metal lamp tube  
1PC

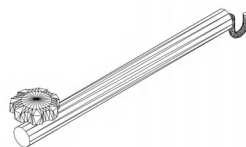

**I**

# PARTS //

Metal lamp tube  
1PC



**J**

Metal lamp tube  
1PC



**K**

Wire roof  
1PC

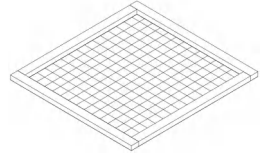

**L**

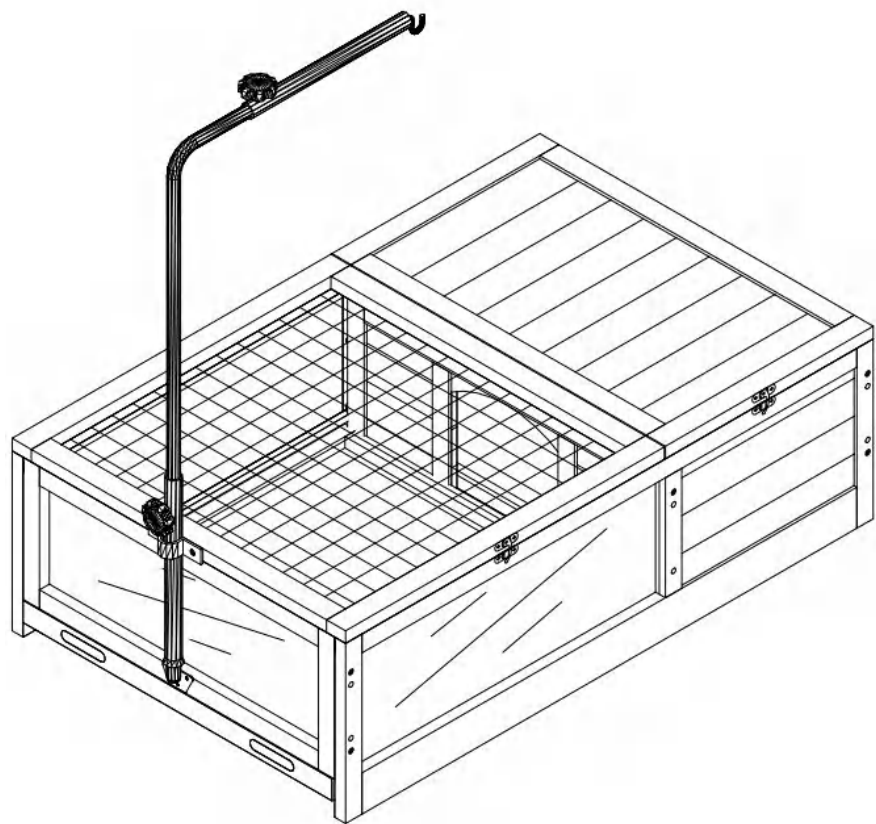

# PRODUCT ASSEMBLY //

**01** Attach Front panel Part A to Parts C,D,E by 6xP1 screws.

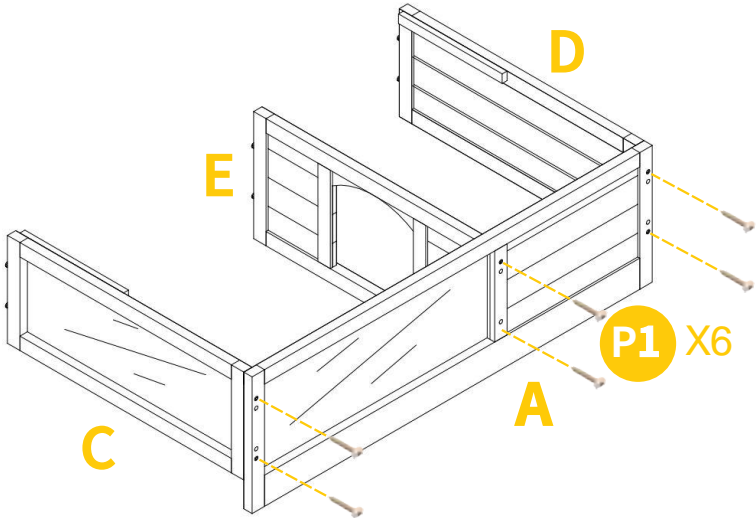

**02** Attach back panel Part B by 6xP1 screws.

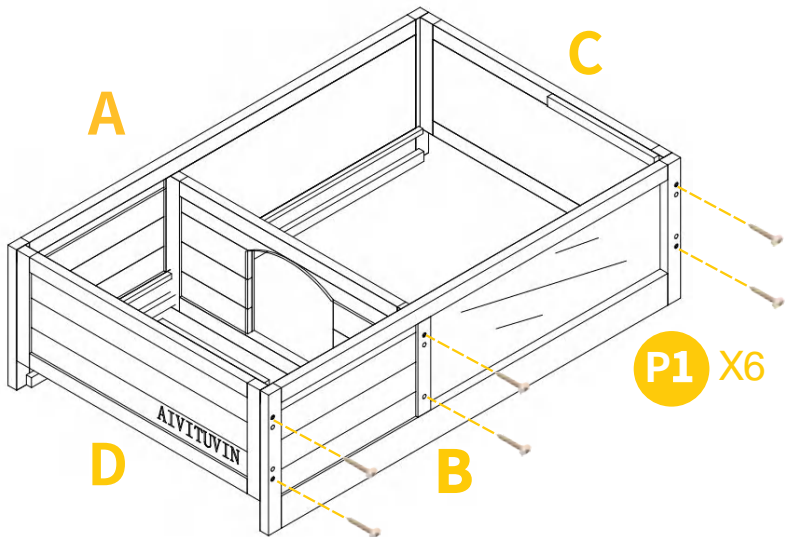



## PRODUCT ASSEMBLY //

**03** Slide in the tray Part F & G from left and right side.

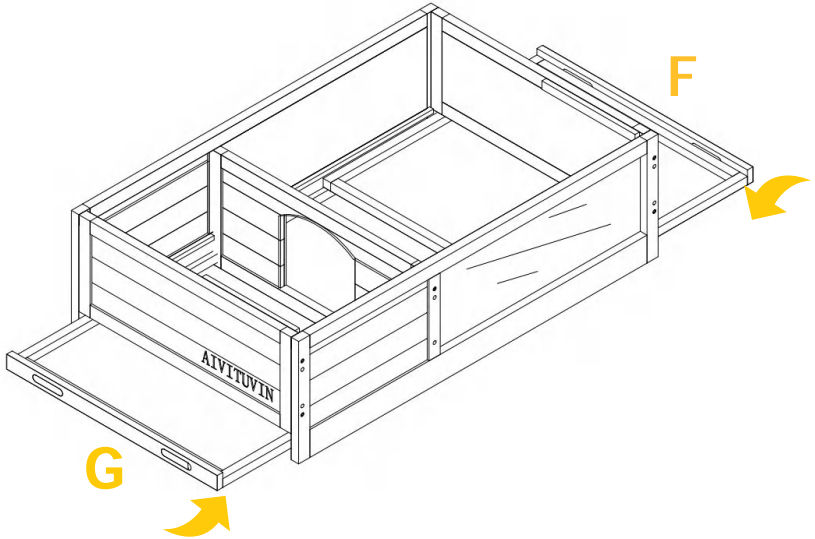

**04** Screw the roof Parts H,L to the house with the hinges by 8xP2 screws.

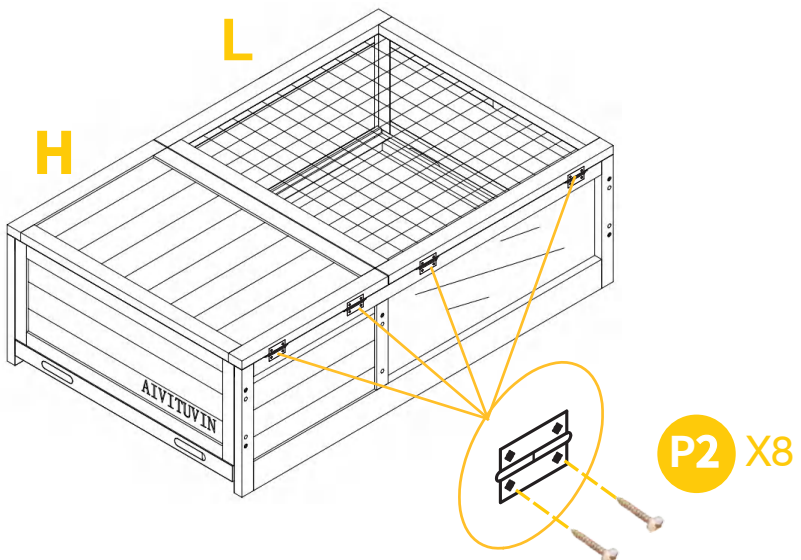

## PRODUCT ASSEMBLY //

**05** Complete the roof by screwing the latch 2xP3 by 8xP2 screws.

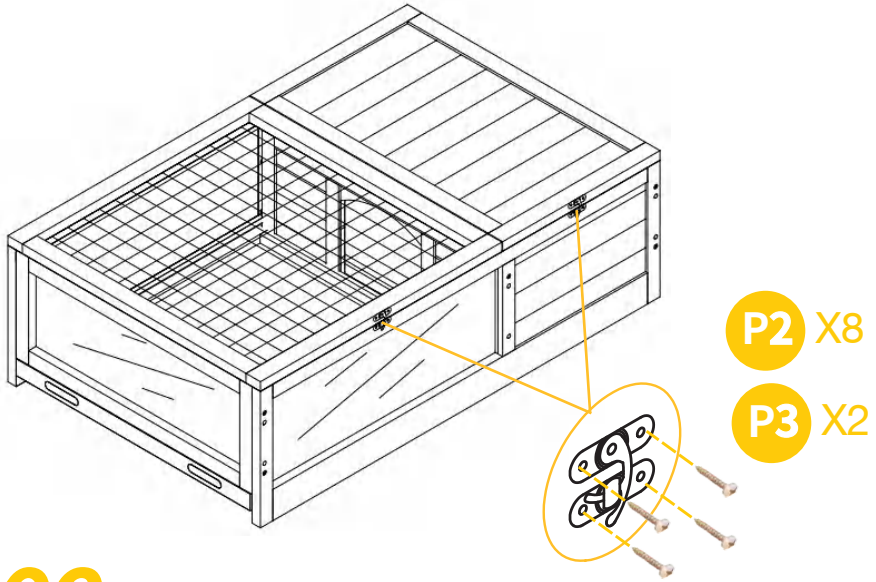

**06** Rota the metal lamp holder firstly.

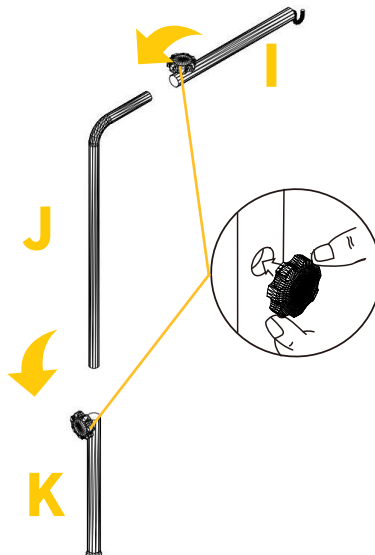

## PRODUCT ASSEMBLY //

**07** Screw it to the cage using the P4 by 2xP2 screws on the upper part; then screw the lower part P5 by 3xP2 screws.

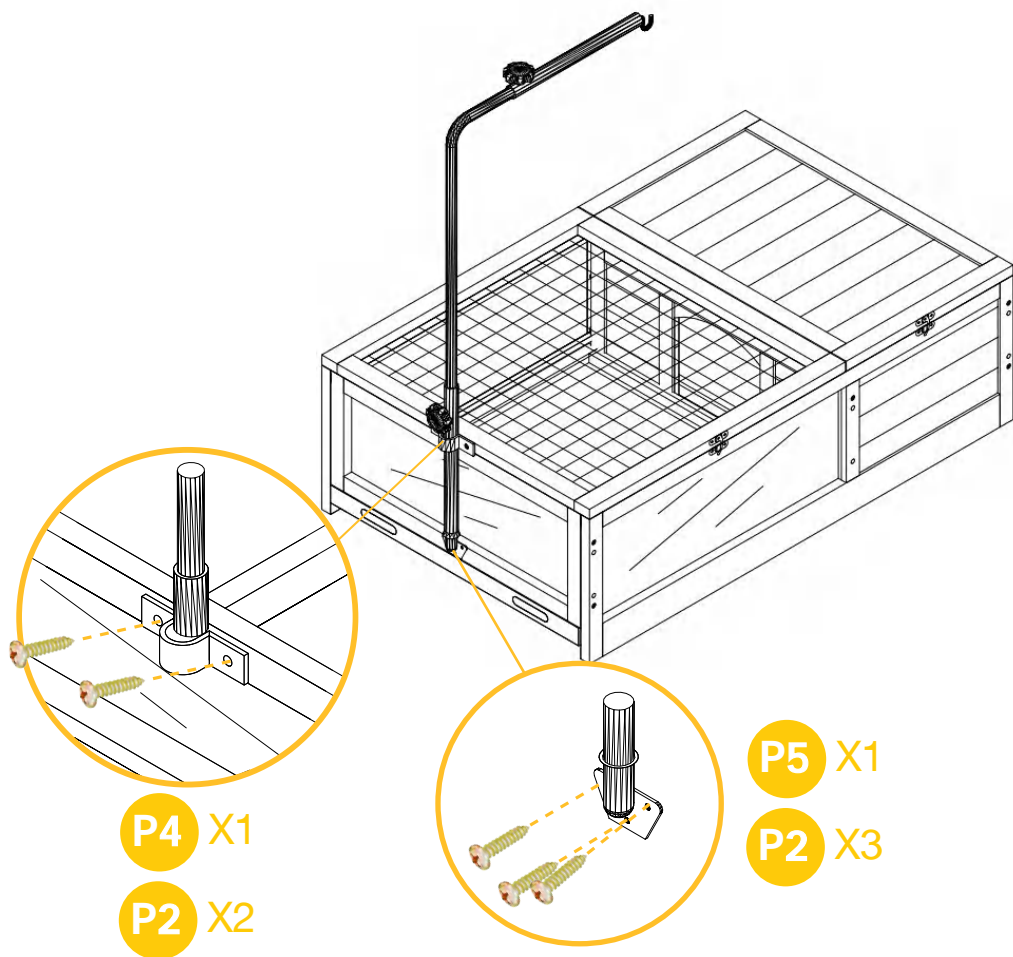



**WARNING**

Manufacturer and seller expressly disclaim any and all liability for personal injury, property damage or loss, whether direct, indirect, or incidental, resulting from the incorrect attachment, improper use, inadequate maintenance, or neglect of this product.