

INSTRUCTION MANUAL

AIR 68

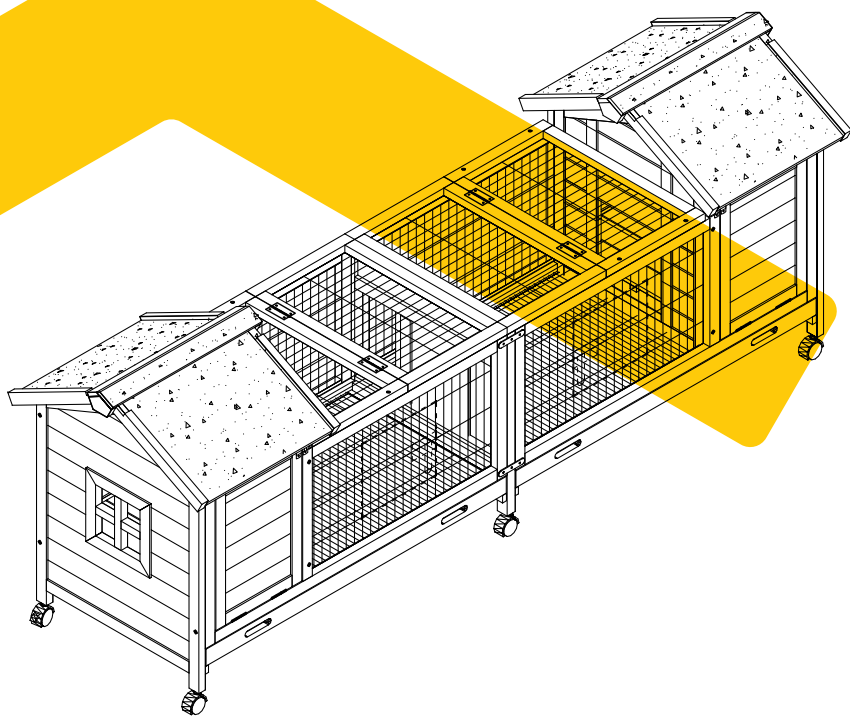

aivotivin

www.aivotivin.com



NOTICE

Please retain these instructions for future reference.

- Firmly secure all bolts,screws and knobs before use.
- Reconfirm that all bolts,screws,and knobs are secure every 90 days.
- Fasten screws loosely during initial assembly. Do not fully tighten screws until the item is completely assembled.
- Do not use or store this item in the proximity of open flame or flammable/combustible chemicals.
- Be aware that some parts are heavy and have sharp edges.
- Be aware that moving parts can injure,crush and cut.
- If any parts are missing,broken,damaged,or worn,stop using this product until repairs are made and/or factory replacement parts are installed.
- Do not use this item in a way inconsistent with the manufacturer's instructions as this could void the product warranty.

TOOLS REQUIRED //



PHILLIPS
SCREWDRIVER

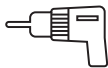

DRILL
(RECOMMENDED)



2PERSON
ASSEMBLY



APPROXIMATELY
45MIN. ASSEMBLY

HARDWARE //

M3.5x45mm SCREW
8PCS+1spare



P1

M3.5x40mm SCREW
16PCS+1spare



P2

M3.5x25mm SCREW
4PCS+1spare



P3

M3.0x16mm SCREW
16PCS+1spare



P4

M3.0x10mm SCREW
2PCS+1spare



P5

Chewing toy
1PC



P6

Connecting Piece
4PCS

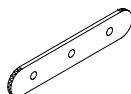

P7

M3.0x16mm SCREW
12PCS+1spare



P8

PARTS //

Front Panel-Right Side
1PC

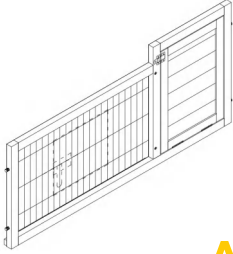

A

Side Panel
2PCS

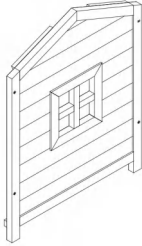

B

Back Panel-Right Side
1PC

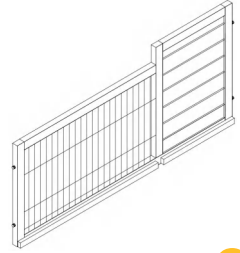

C

House Divider
2PCS

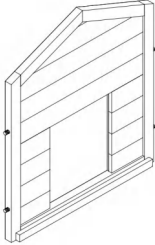

D

Run Divider
1PC

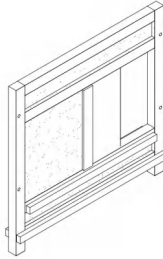

E

Support Bar
2PCS

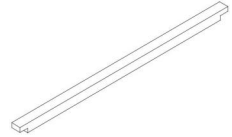

F

Tray
2PCS

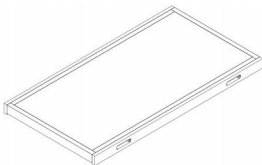

G

Wire Floor
2PCS

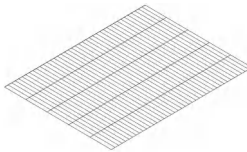

H

Wooden Floor
2PCS

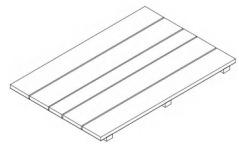

I

PARTS

Folding metal feeder
1PC

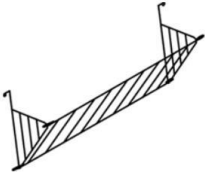

J

Roof
4PCS

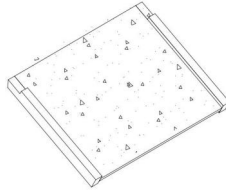

K

Pen Cover
2PCS

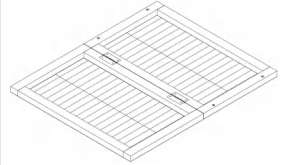

L

Roof Cap
2PCS

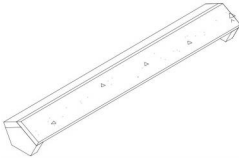

M

Front Panel-Left Side
1PC

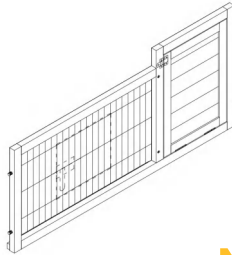

N

Back Panel- Left Side
1PC

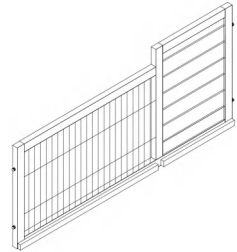

O

Caster With Brake
3PCS



P

Caster Without Brake
3PCS



Q

PRODUCT ASSEMBLY //

01

Screw Part A, B, C, D together by 4XP1 & 4XP2 screws.

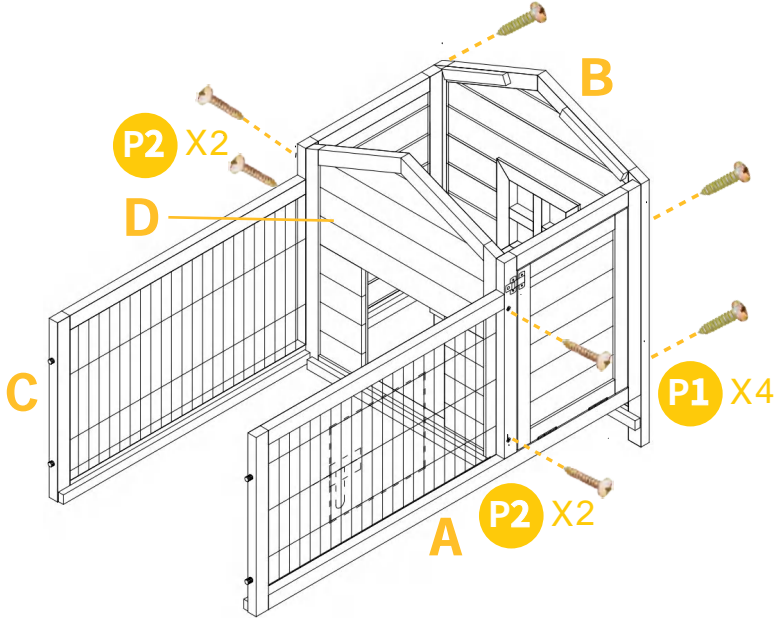

02

Use the connecting piece P7 to attached Part E by 4XP8 each side.

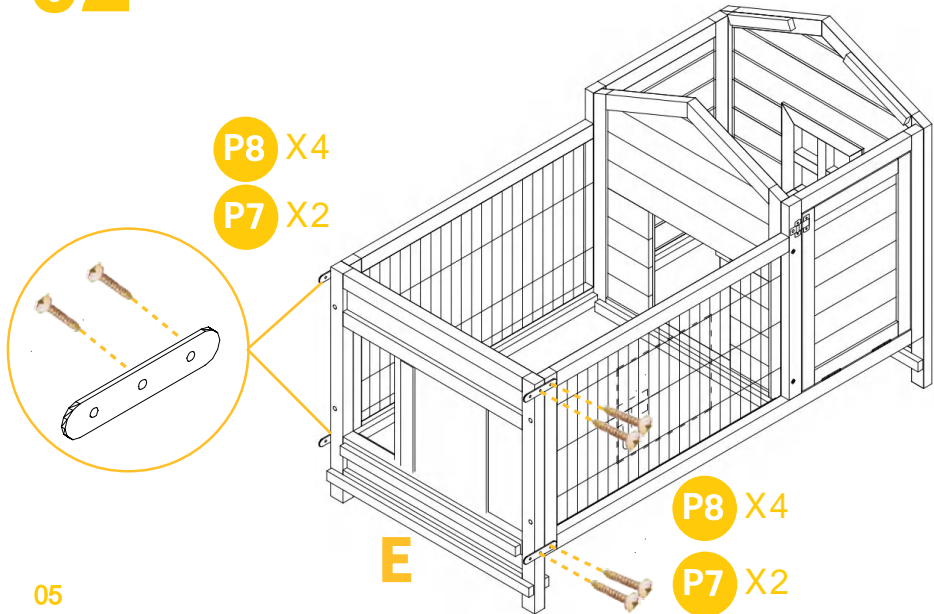

PRODUCT ASSEMBLY //

03 Screw in the casters Part P & Q to the legs.

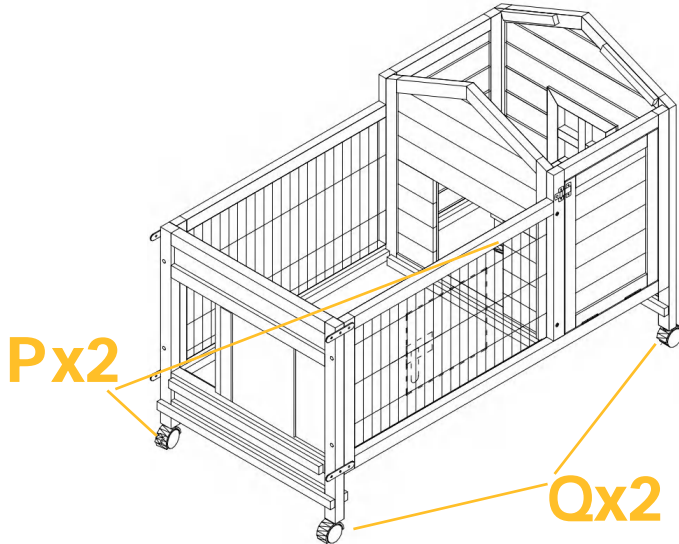

04 Slide in the plastic tray Part G.
Put the support bar Part F into the pen.

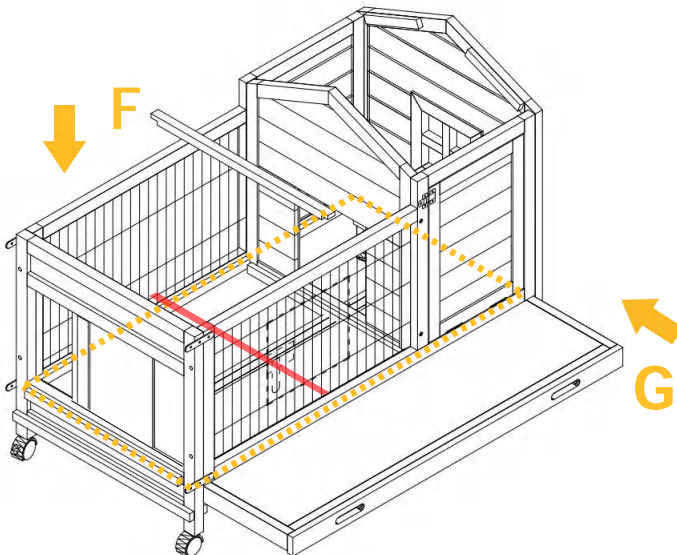

PRODUCT ASSEMBLY //

05 Put in the floor Part H & I.

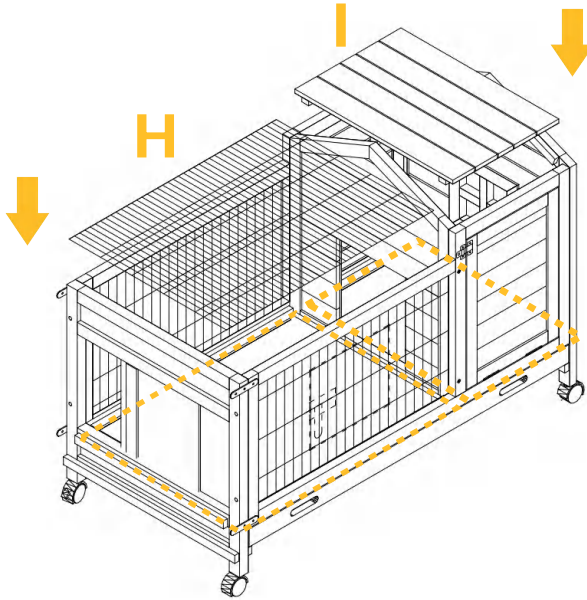

06 Attach metal feeder Part J by 2XP5 screw, then put in the chewing toy.

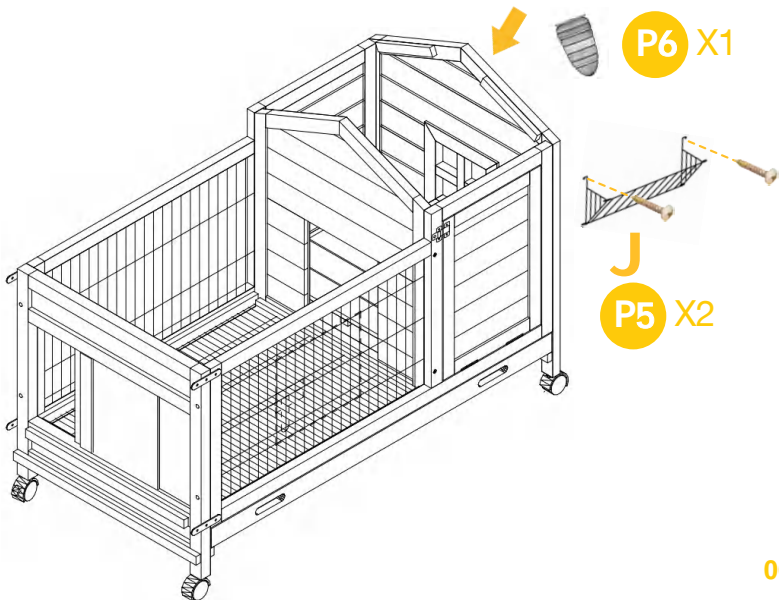

PRODUCT ASSEMBLY //

07 Attach the pen roof Part L by 4XP2 screws.

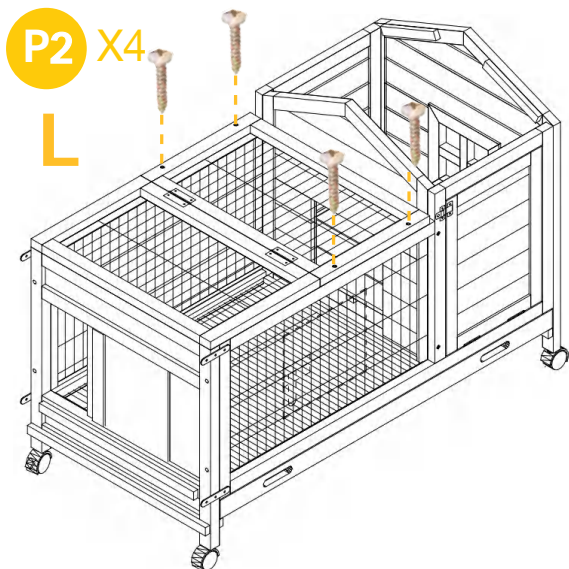

08 Attach the roof Part K by 4XP4 screw each side.

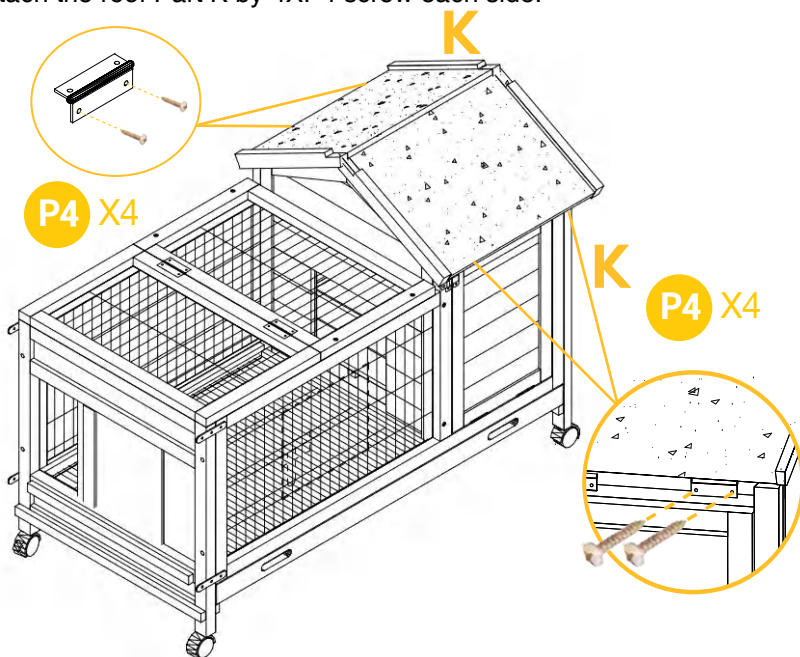

PRODUCT ASSEMBLY //

09 Attach the roof cap Part M by 2XP3 screws.

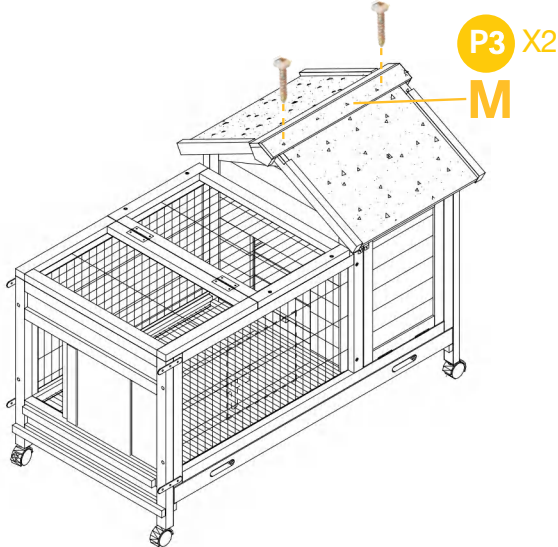

10 Screw Part N, O, B, D together by 4XP1 & 4XP2 screws.
Screw in the casters Part P & Q to the legs
Repeat the same assembly ways of Step 2 to Step 9.

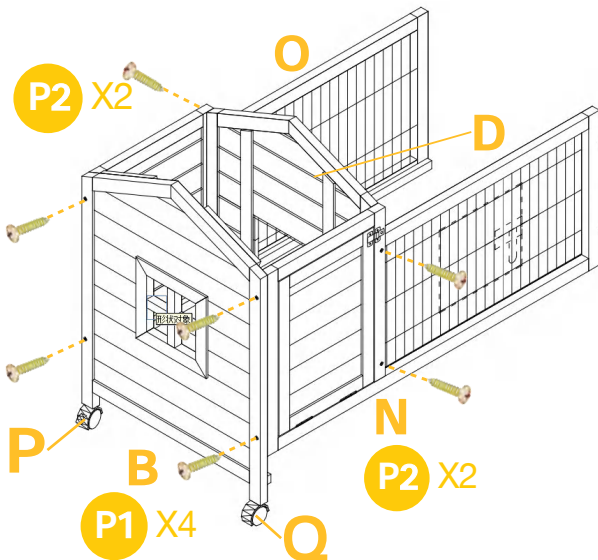

PRODUCT ASSEMBLY //

11 Connect two hutches together by 2XP8 each side.

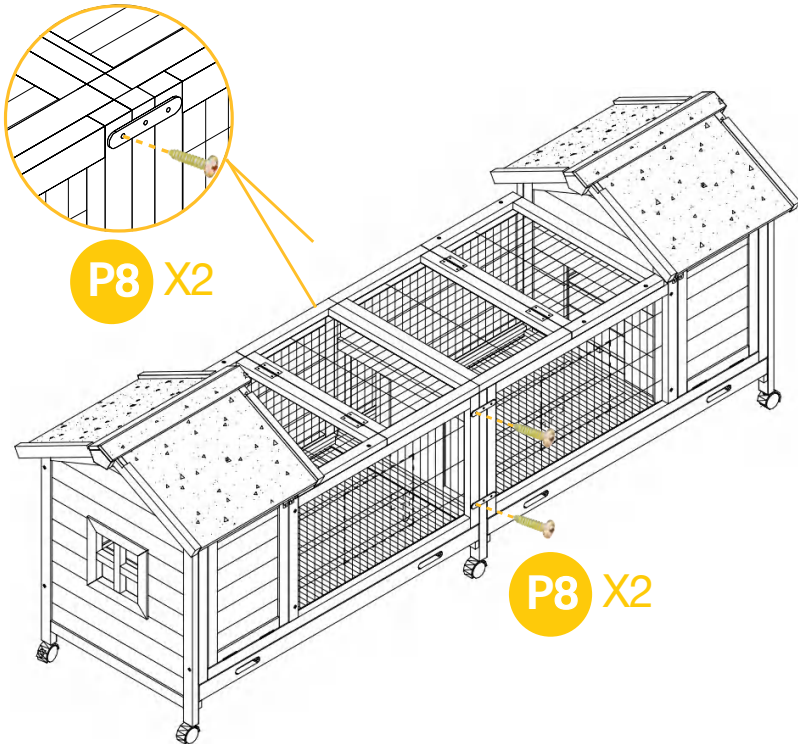

Finish



WARNING

Manufacturer and seller expressly disclaim any and all liability for personal injury, property damage or loss, whether direct, indirect, or incidental, resulting from the incorrect attachment, improper use, inadequate maintenance, or neglect of this product.