

INSTRUCTION MANUAL

AIR20-B

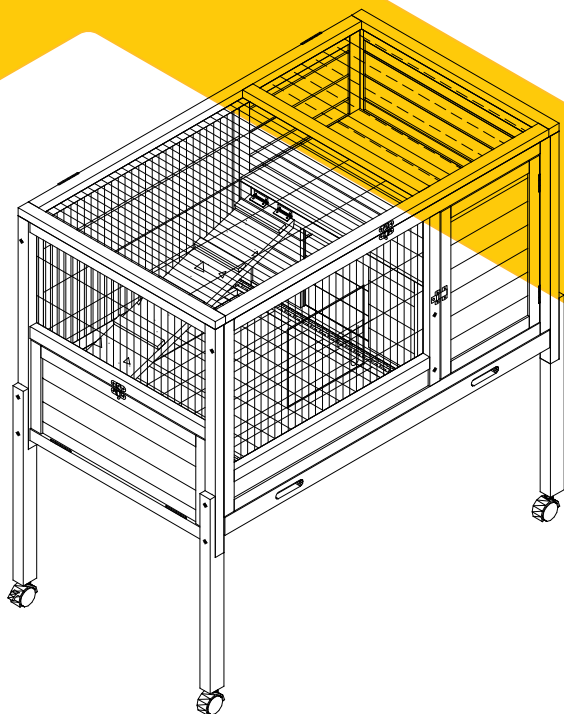



NOTICE

Please retain these instructions for future reference.

- Firmly secure all bolts, screws and knobs before use.
- Reconfirm that all bolts, screws, and knobs are secure every 90 days.
- Fasten screws loosely during initial assembly. Do not fully tighten screws until the item is completely assembled.
- Do not use or store this item in the proximity of open flame or flammable/combustible chemicals.
- Be aware that some parts are heavy and have sharp edges.
- Be aware that moving parts can injure, crush and cut.
- If any parts are missing, broken, damaged, or worn, stop using this product until repairs are made and/or factory replacement parts are installed.
- Do not use this item in a way inconsistent with the manufacturer's instructions as this could void the product warranty.

TOOLS REQUIRED //



PHILLIPS
SCREWDRIVER

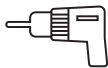

DRILL
(RECOMMENDED)



2PERSON
ASSEMBLY



APPROXIMATELY
45MIN. ASSEMBLY

HARDWARE //

M3.5x45mm SCREW
12PCS spare



P1

M3.5x35mm SCREW
8PCS +1spare



P2

M3.0x16mm SCREW
18PCS+1spare



P3

M3.0x10mm SCREW
2PCS + 1spare



P4

Eye hook
1PC



P5

Latch
2PCS



P6

Chewing Toy for Gift
1PC



P7

PARTS

Front Panel
1 PC

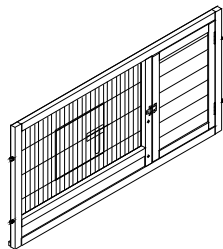

A

Back Panel
1 PC

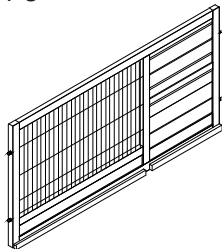

B

Left Panel
1 PC

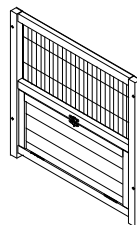

C

Right Panel
1 PC

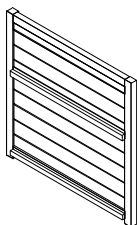

D

Sliding Tray
1 PC

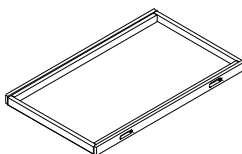

E

Top Cover Panel
1 PC

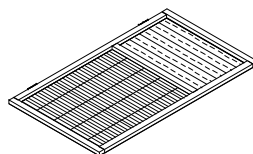

F

Ramp
1 PC

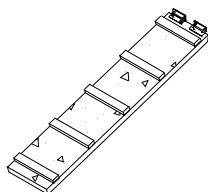

G

Layer
1 PC

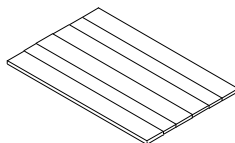

H

Divider
1 PC

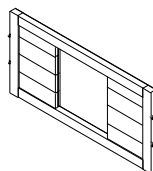

I

PARTS

Wood Floor
1 PC

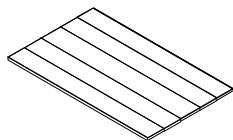

J

Brake Casters
2 PCS



K

Castors without brake
2 PCS



L

Bottom Wire Netting
1 PC

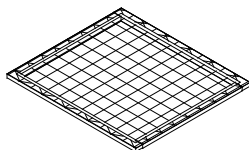

M

Extra Hutch Legs
(Optional)
4 PCs



N

Folding Metal feeder
1 PCS

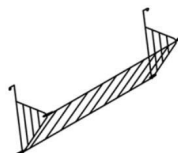

O

Wood shelf
1 PC

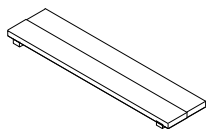

P

PRODUCT ASSEMBLY

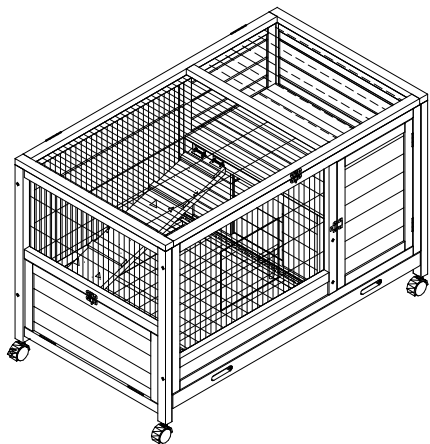

OPTIONAL- HUTCH ON THE GROUND

Follow the step from step 1 to step 10 to finish!

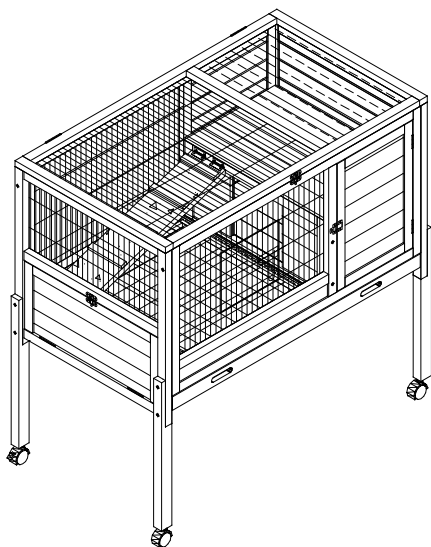

OPTIONAL- HUTCH WITH 4 HIGH LEGS.

Follow the step from step 1 to step 8, skip the Step9 & Step 10, then go on until the last step to finish!

PRODUCT ASSEMBLY //

01 Attach Part A, Part C and Part D by 4xP1 screws. And then attach divider Part I to Part A by 2xP1 screws.

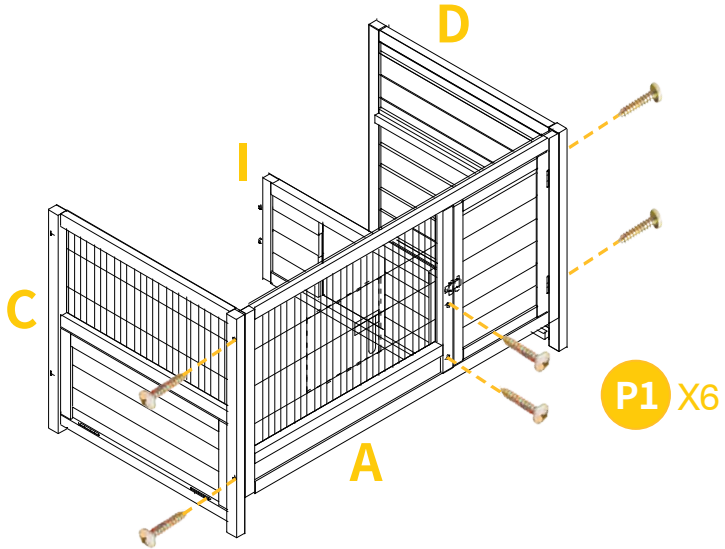

02 Attach back panel Part B by 4xp1 screws. And Screw another side of divider to the back by 2xP1 screws.

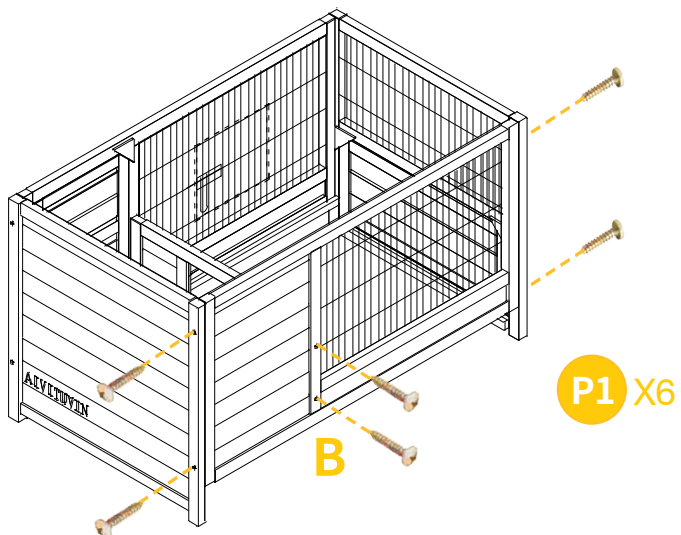

PRODUCT ASSEMBLY //

03 Slide in the tray Part E.

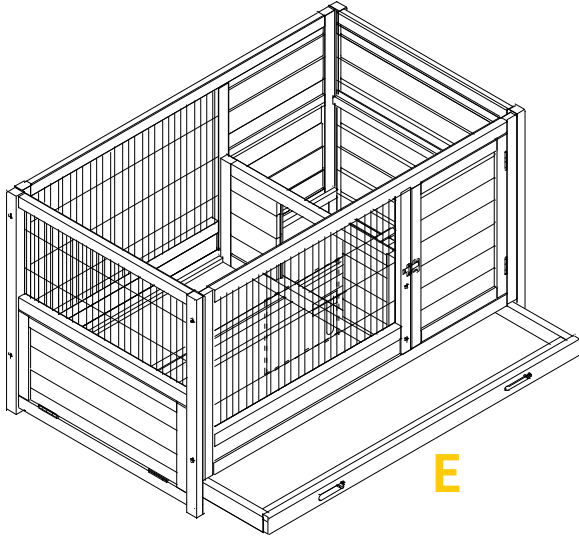

04

Put inside the bottom wire netting PART M to be **UPWARDS**, to separate the urine & poop.

Put inside the wood floor Part J as show on the picture.
Put inside the wood shelf Part P as show on the picture.

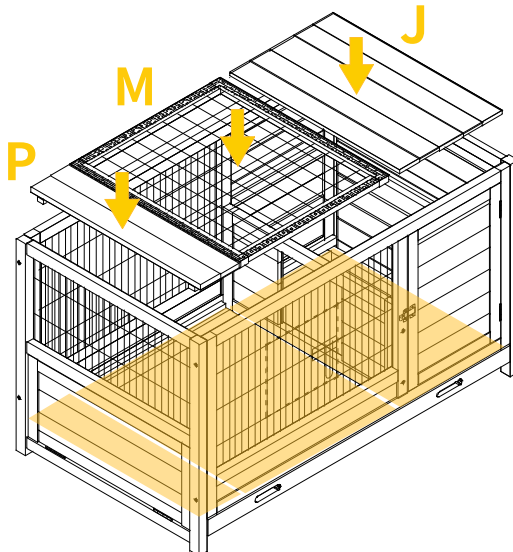

PRODUCT ASSEMBLY //

05

Screw the ramp Part G to the upper frame of divider Part I by 4xP3. Put the layer Part H above the divider, it can be removable freely to catch the pets. Put the chewing toy P7 inside the cage anywhere you want.

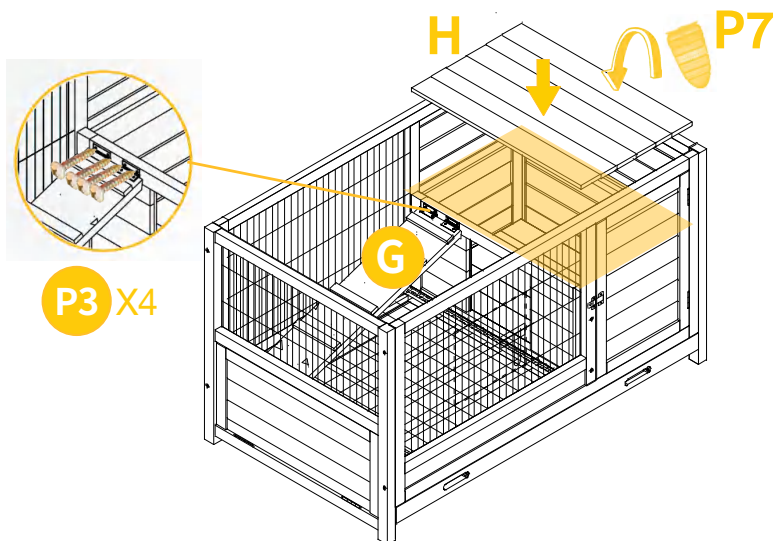

06

Attach the top cover panel Part F to the house by 6xP3 screws.

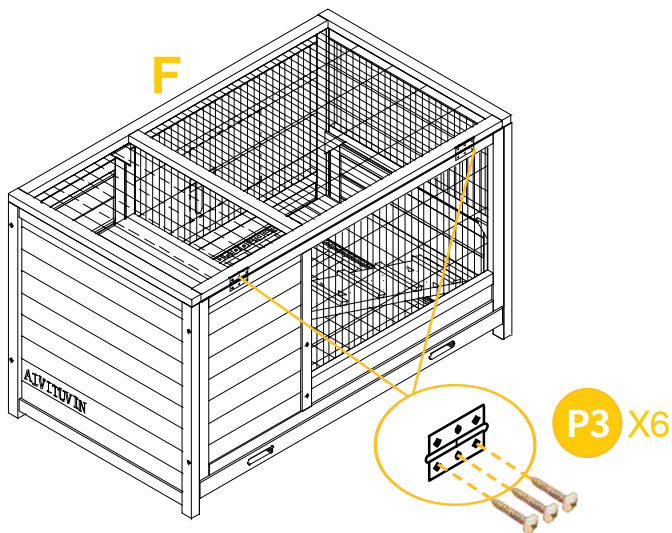

PRODUCT ASSEMBLY //

07

Screw the folding metal feeder Part O to the inside of Part D by 2xP4 screws.

Screw the eye hook P5 to the Part C, tie the rope on one side of roof ,the other side of hook to make the roof open.

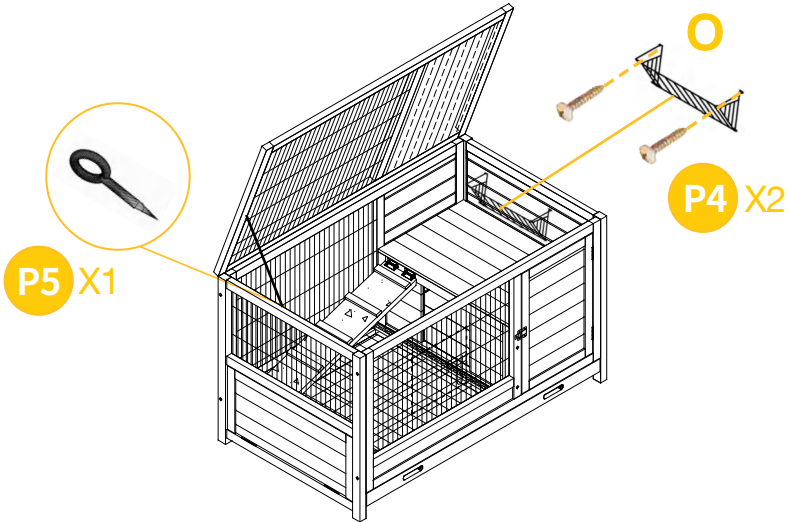

08

Screw latch P6 to the Part C by 4XP3 screws as show on picture. Screw latch P6 by 4xP3 screws to connect the top and front panels.

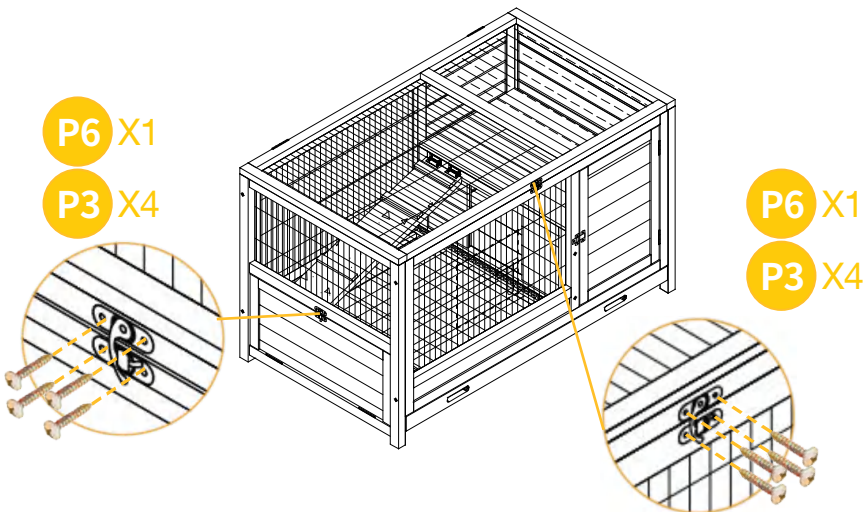

PRODUCT ASSEMBLY //

Below steps are optional:

If you want to put the the hutch on the ground, follow the Step 9, Step 10 to finish!

If you want to make the hutch with 4 higher legs, just skip Step 9, Step 10 and go on Step 11 to Step 14 to finish.

09

Screw two brake casters Part K to the back of hutch legs.

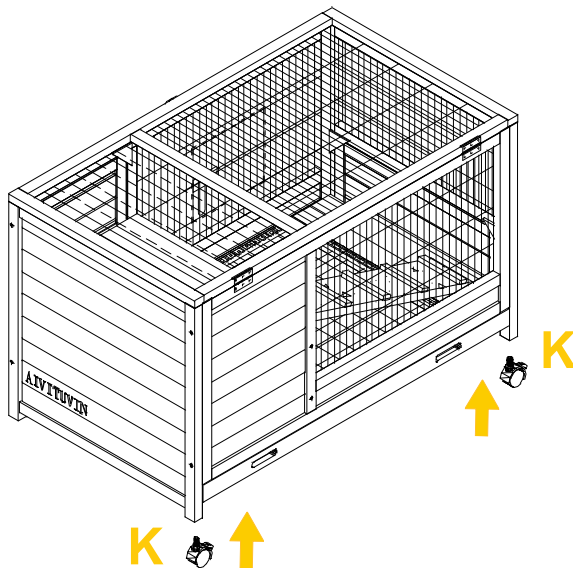

PRODUCT ASSEMBLY //

- 10** Screw two casters without brake Part L to the front of hutch legs.

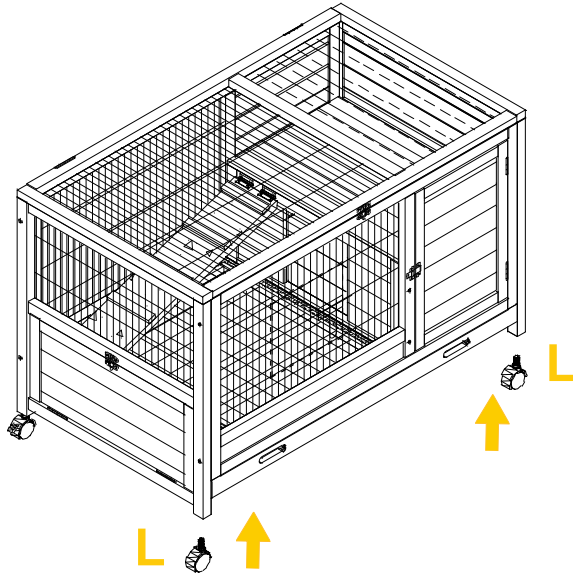

- 11** Attach the extra high legs Part N to the front by 2xP2 screws each side.

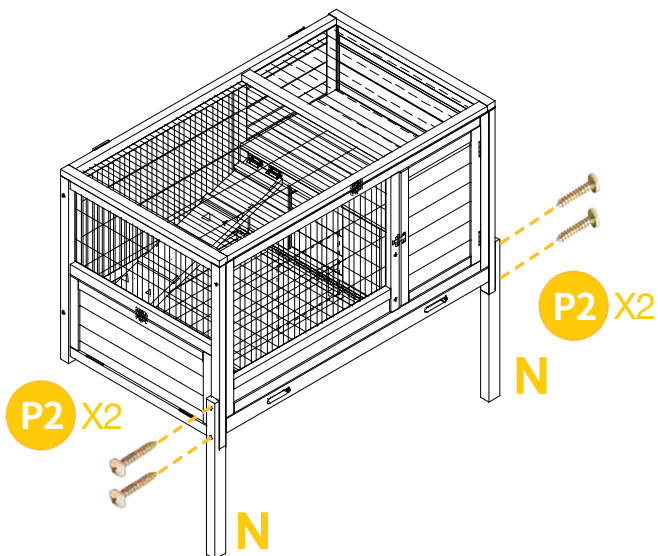

PRODUCT ASSEMBLY //

12 Attach the extra high legs Part N to the back by 2xP2 screws each side.

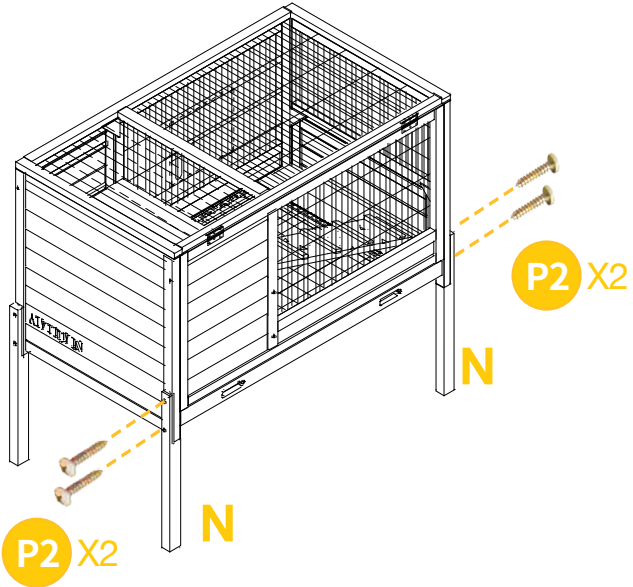

13 Screw two brake casters Part K to the back of hutch legs.

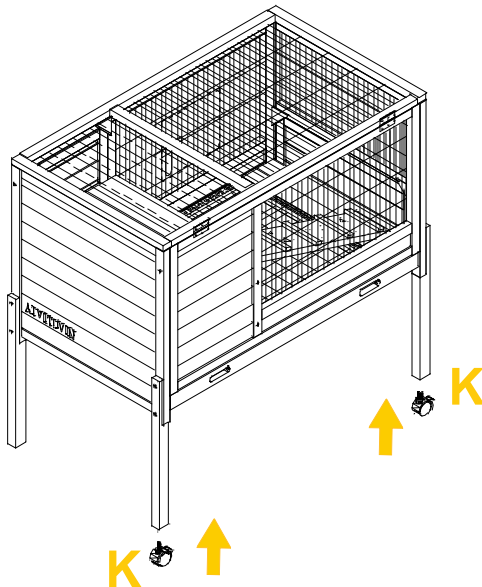

PRODUCT ASSEMBLY //

14 Screw two casters without brake Part L to the front of hutch legs.

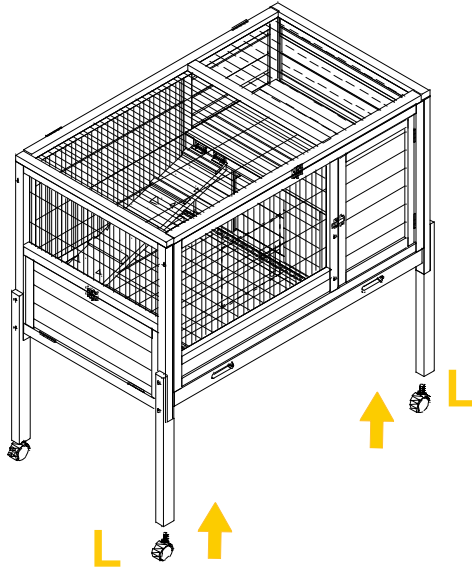



WARNING

Manufacturer and seller expressly disclaim any and all liability for personal injury, property damage or loss, whether direct, indirect, or incidental, resulting from the incorrect attachment, improper use, inadequate maintenance, or neglect of this product.