

# INSTRUCTION MANUAL

AIR 15

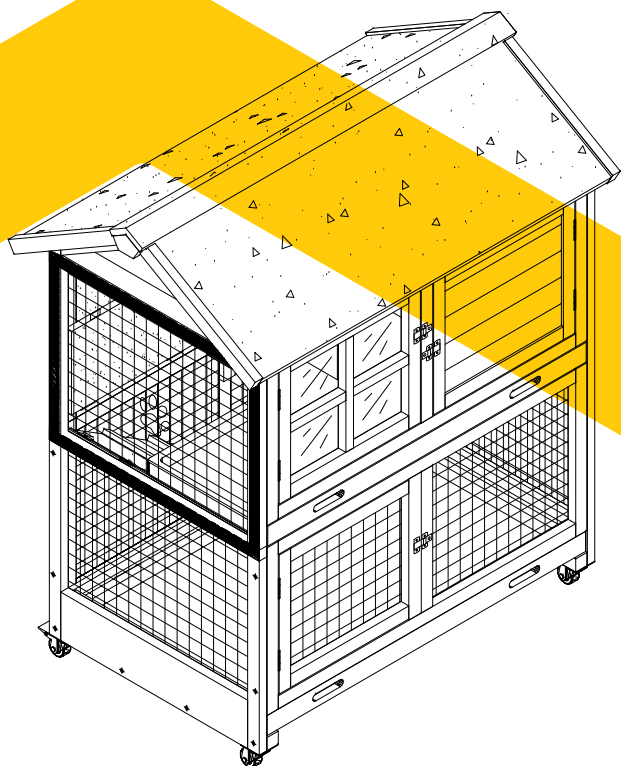

The logo for aivituvín, featuring a stylized house icon above the brand name.

[www.aivituvin.com](http://www.aivituvin.com)





## NOTICE

Please retain these instructions for future reference.

- Firmly secure all bolts,screws and knobs before use.
- Reconfirm that all bolts,screws,and knobs are secure every 90 days.
- Fasten screws loosely during initial assembly. Do not fully tighten screws until the item is completely assembled.
- Do not use or store this item in the proximity of open flame or flammable/combustible chemicals.
- Be aware that some parts are heavy and have sharp edges.
- Be aware that moving parts can injure,crush and cut.
- If any parts are missing,broken,damaged,or worn,stop using this product until repairs are made and/or factory replacement parts are installed.
- Do not use this item in a way inconsistent with the manufacturer's instructions as this could void the product warranty.

## TOOLS REQUIRED //



PHILLIPS  
SCREWDRIVER

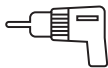

DRILL  
(RECOMMENDED)



2PERSON  
ASSEMBLY



APPROXIMATELY  
45MIN. ASSEMBLY

## HARDWARE //

M4.0x45mm SCREW  
18PCS+1spare



P1

M3.5x35mm SCREW  
8PCS+1spare



P2

M3.5x25mm SCREW  
20PCS+1spare



P3

M3.0x16mm SCREW  
2PCS+1spare



P4

M3.0x10mm SCREW  
2PCS+1spare



P5

Chewing toy  
1PC



P6

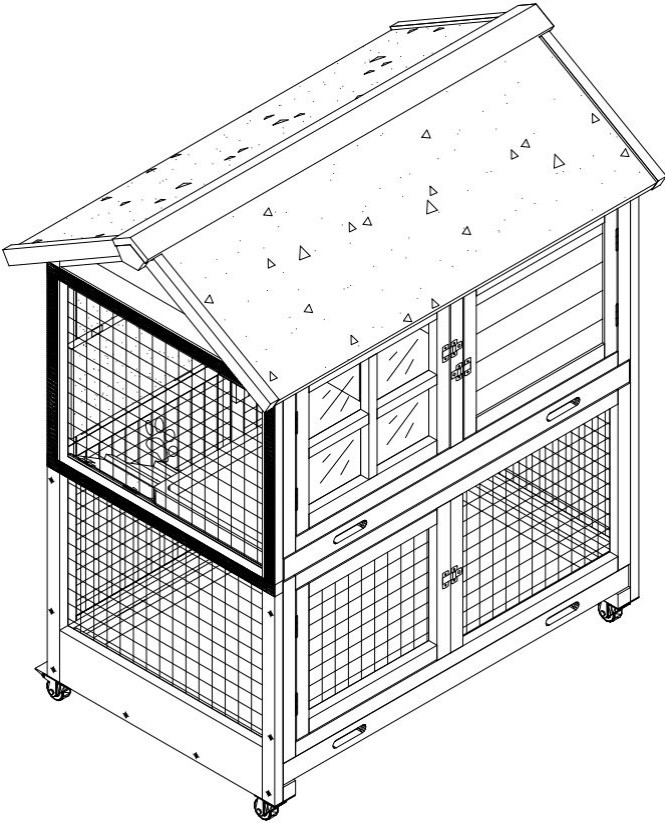

# PARTS

Front panel - Upper  
1PC

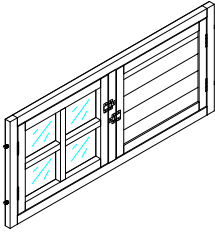

**A**

Front panel - Down  
1PC

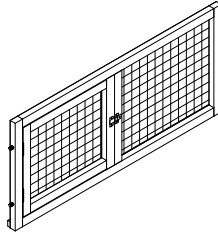

**B**

Back panel - Up  
1PC

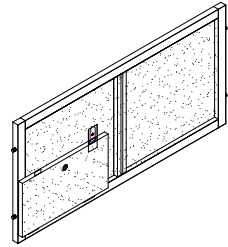

**C**

Back panel - Down  
1PC

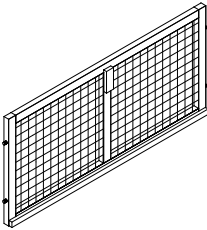

**D**

Left panel  
1PC

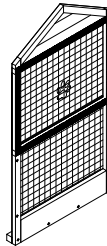

**E**

Right panel  
1PC

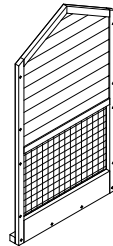

**F**

Middle plastic tray  
1PC

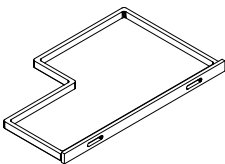

**G**

Divider  
1PC

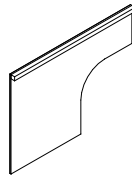

**H**

Bottom wire netting  
2PCS

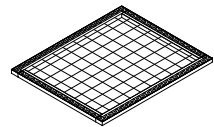

**I**

# PARTS

Ramp  
1PC

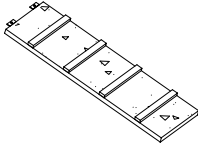

J

Bottom plastic tray  
1PC

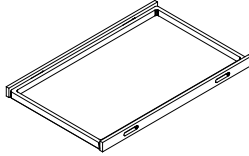

K

Asphalt roof x2  
2PCS

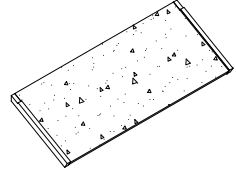

L

Roof cap  
1PC

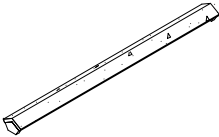

M

Casters without brake  
2PCS



N

Brake casters  
2PCS

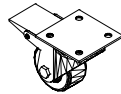

O

Folding metal feeder  
1PC

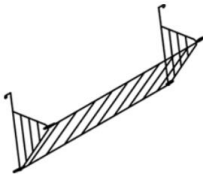

P

Ramp Supporting board  
1PC

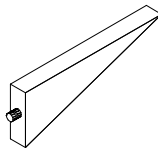

Q

# PRODUCT ASSEMBLY //

- 01** Attach the back panels up Part C, down Part D to the left side panel Part E and right side Part F by 4xP1 screws each side.

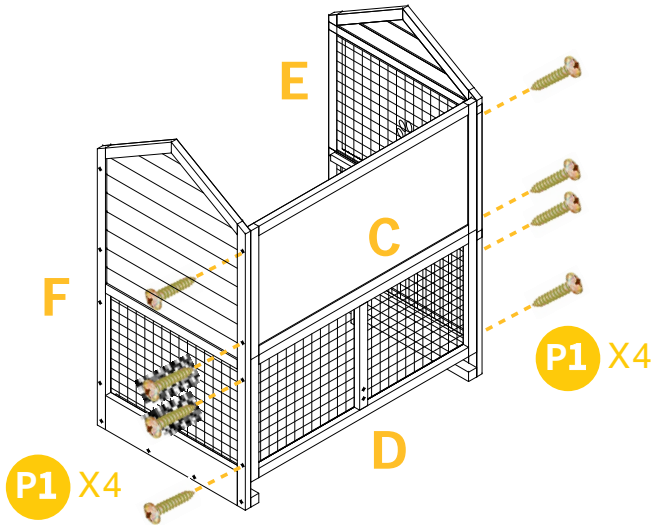

- 02** Attach the down panel Part B by 2xP1 screws each side.

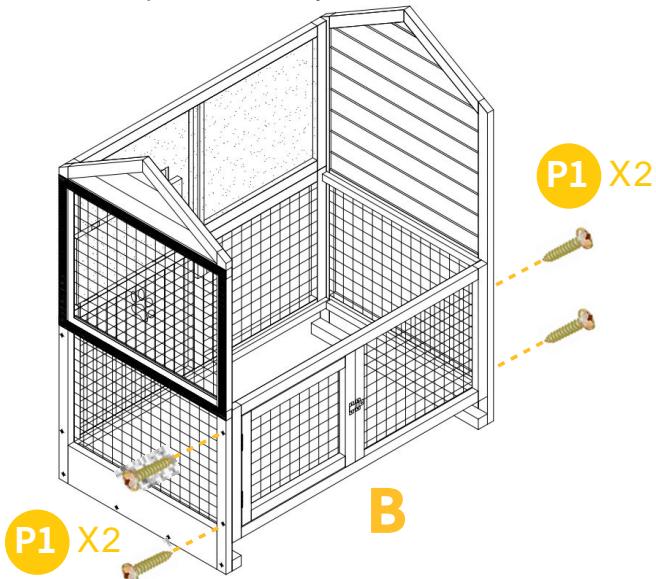



## PRODUCT ASSEMBLY //

- 03** Put inside the wire bottom floor Part I to be **UPWARDS** in order to separate the urine & poop.

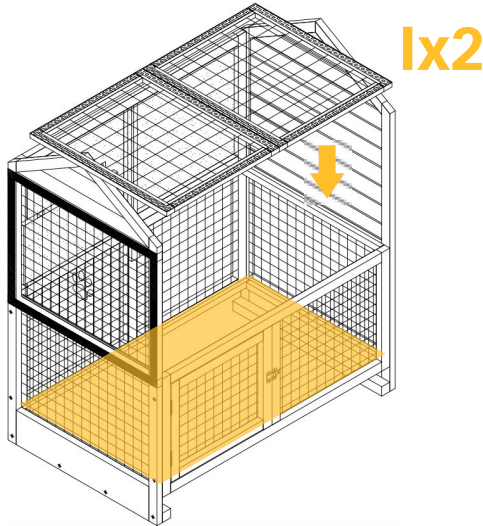

- 04** Screw the ramp supporting board Part Q to the Part D by 2xP2 screws.  
( Notice: The ramp supporting board Part Q is only assembled if you don't need the bottom wire netting)

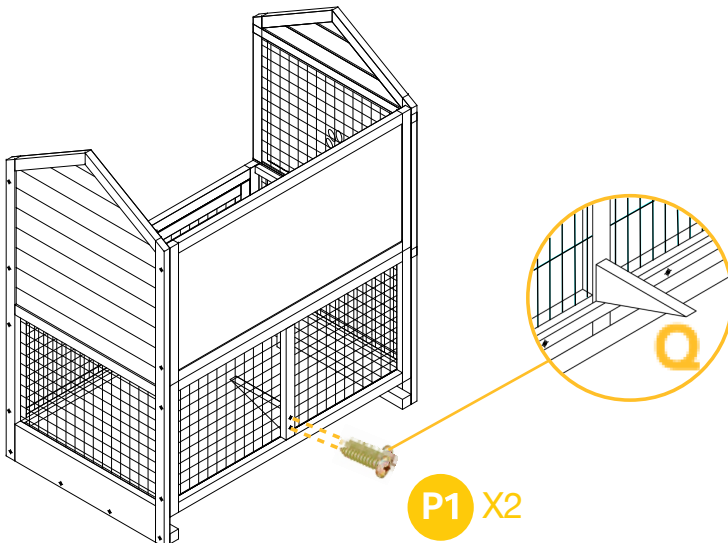

## PRODUCT ASSEMBLY //

**05** Screw the ramp Part J to the bar of Part E by 2xP4 screws.

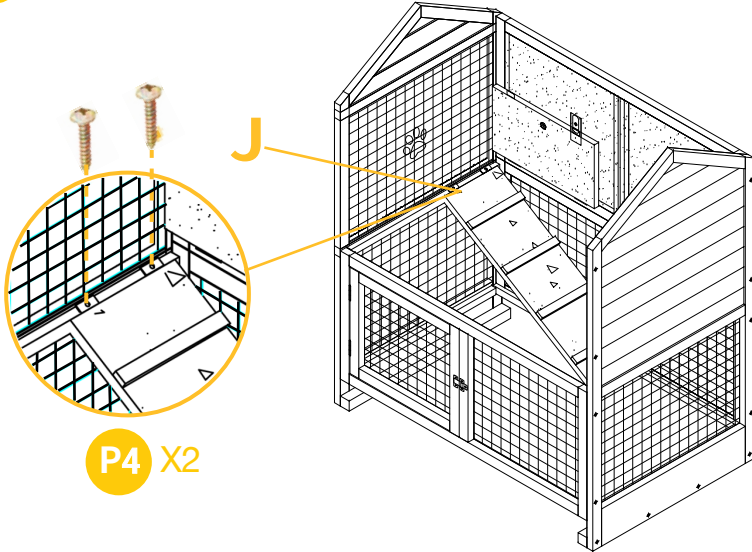

**06** Attach Part A by 2xP1 screws each side.

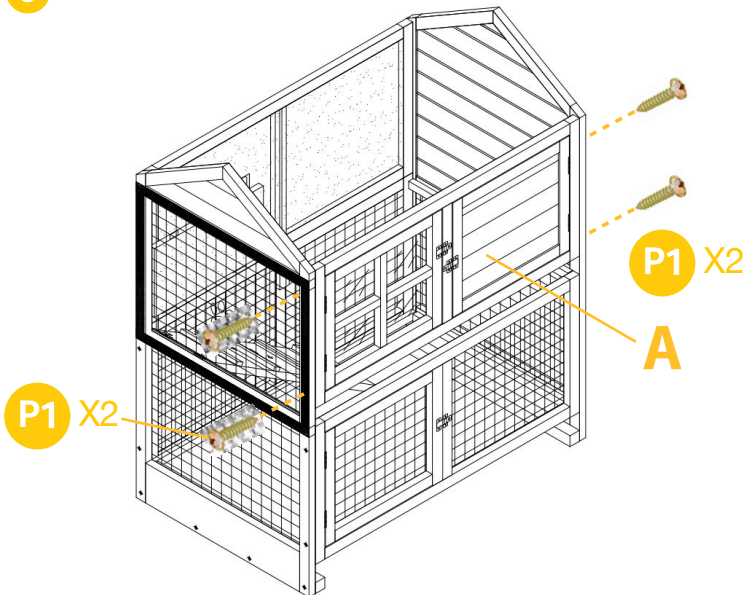

## PRODUCT ASSEMBLY //

**07** Slide in the middle tray Part G and bottom tray Part K.

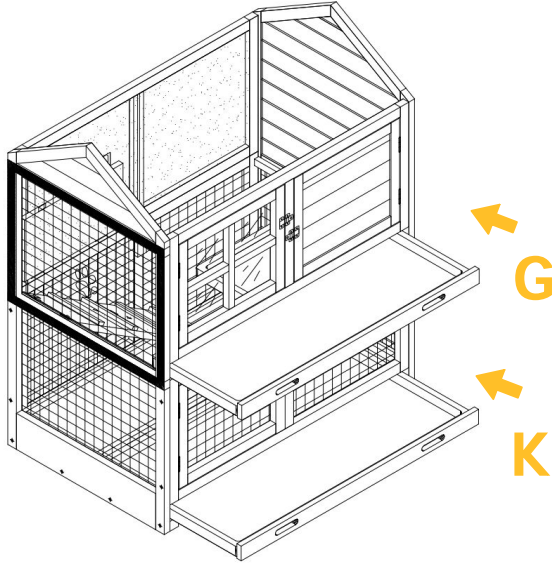

**08** Screw the metal feeder Part P to the Part F by 2xP5 screws.

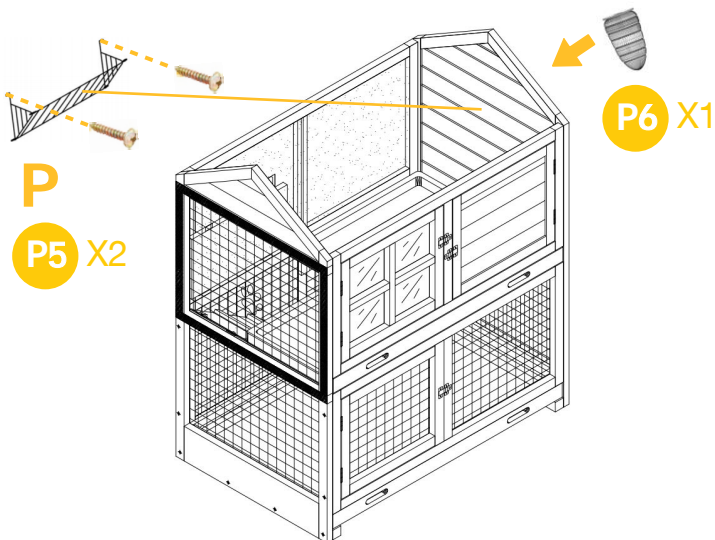

## PRODUCT ASSEMBLY //

**09** Slide in the divider Part H.

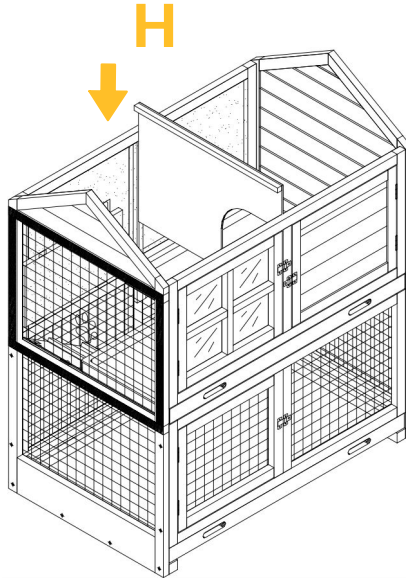

**10** Screw two casters without brake Part N to the front of hutch legs by P3x8 screws.

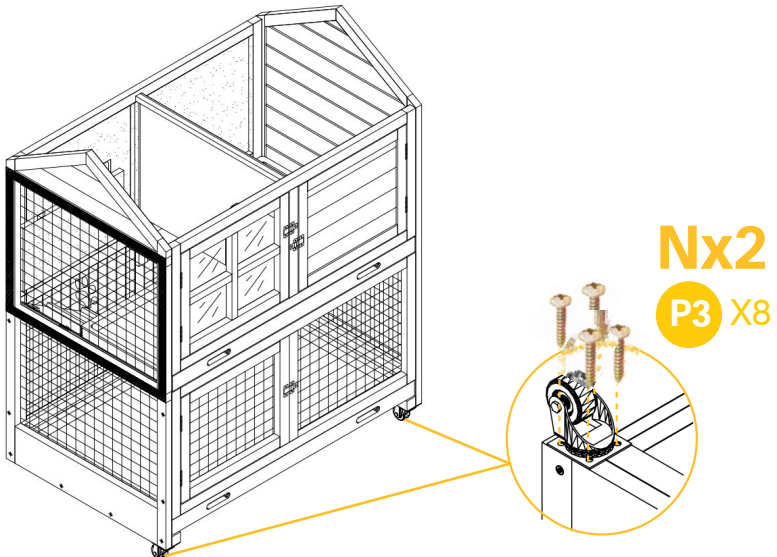

## PRODUCT ASSEMBLY //

- 11** Screw two brake casters Part O to the back of hutch legs by P3X8 screws.

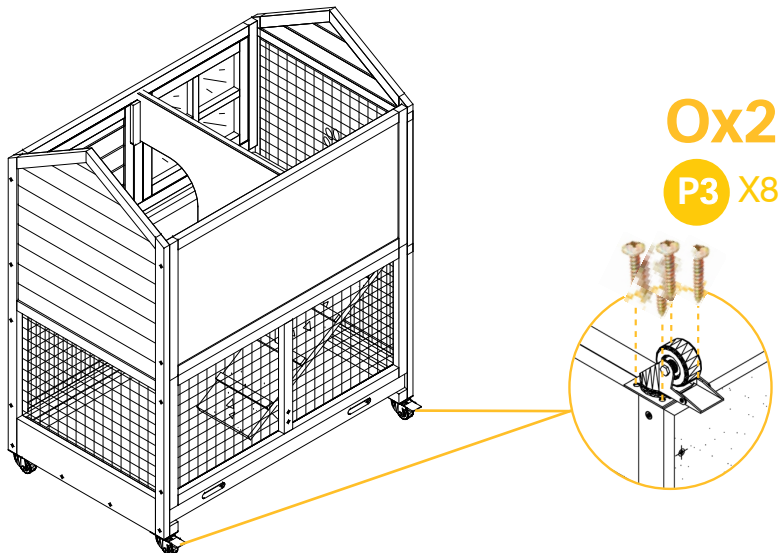

- 12** Screw the 2 roof Part L to the top by 8xP2. Notice to level up the roof.

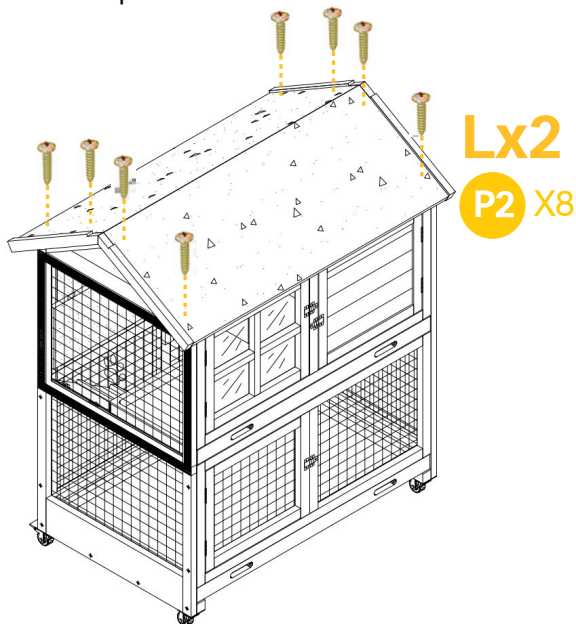

## PRODUCT ASSEMBLY //

**13** Screw the roof cap Part M by 4xP3 screws.

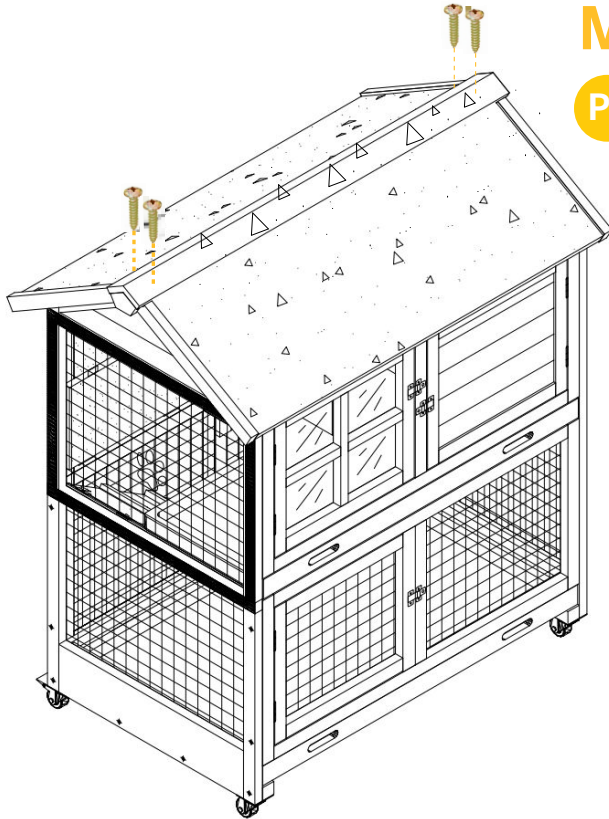

**M**

**P3** X4

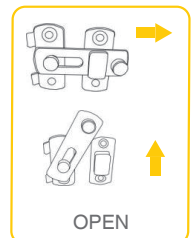
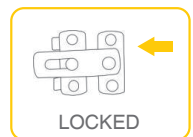

**Finish**





**WARNING**

Manufacturer and seller expressly disclaim any and all liability for personal injury, property damage or loss, whether direct, indirect, or incidental, resulting from the incorrect attachment, improper use, inadequate maintenance, or neglect of this product.