

INSTRUCTION MANUAL

AIR06-C

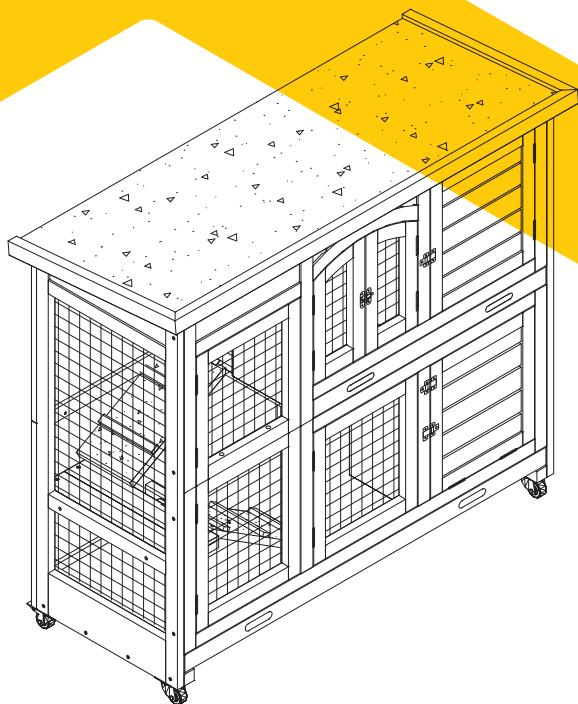

 aivotvin

www.aivotvin.com



NOTICE

Please retain these instructions for future reference.

- Firmly secure all bolts,screws and knobs before use.
- Reconfirm that all bolts,screws,and knobs are secure every 90 days.
- Fasten screws loosely during initial assembly. Do not fully tighten screws until the item is completely assembled.
- Do not use or store this item in the proximity of open flame or flammable/combustible chemicals.
- Be aware that some parts are heavy and have sharp edges.
- Be aware that moving parts can injure,crush and cut.
- If any parts are missing,broken,damaged,or worn,stop using this product until repairs are made and/or factory replacement parts are installed.
- Do not use this item in a way inconsistent with the manufacturer's instructions as this could void the product warranty.

TOOLS REQUIRED //



PHILLIPS
SCREWDRIVER

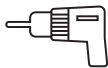

DRILL
(RECOMMENDED)



2PERSON
ASSEMBLY



APPROXIMATELY
45MIN. ASSEMBLY

HARDWARE //

M6.0x50mm BOLT
3PCS+1spare



P1

M3.5x60mm SCREW
2PCS+1spare



P2

M3.5x40mm SCREW
9PCS+1spare



P3

M3.5x35mm SCREW
11PCS+1spare



P4

M3.5x25mm SCREW
16PCS+1spare



P5

M3.5x20mm SCREW
5PCS+1spare



P6

M3.0x16mm SCREW
18PCS+1spare



P7

M3.0x10mm SCREW
2PCS+1spare



P8

HARDWARE //

2PCS



P9

1PC



P10

1PC



P11

M3.5x20mm SCREW
4PCS+1 spare



P12

PARTS

Front upper panel
1PC

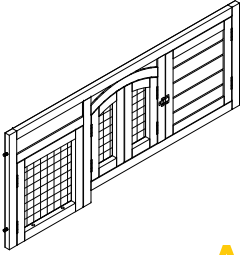

A

Front down panel
1PC

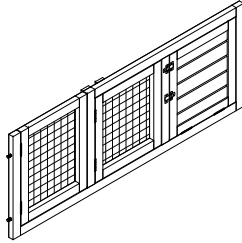

B

Back upper panel
1PC

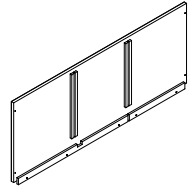

C

Back down panel
1PC

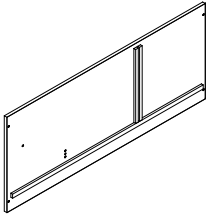

D

Left side panel
1PC

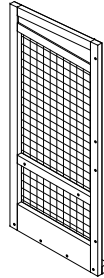

E

Right side panel
1PC

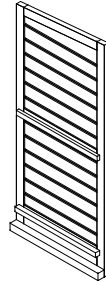

F

Upper plastic tray
1PC

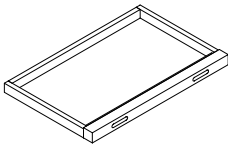

G

Down plastic tray
1PC

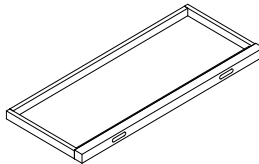

H

Upper divider
2PCS

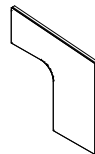

I

PARTS

Down divider
1PC

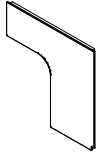

J

Supporter of tray
1PC

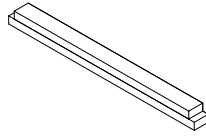

K

Upper ramp
1PC

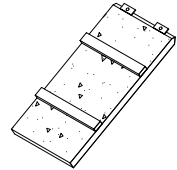

L

Down ramp
1PC

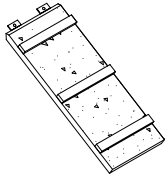

M

Supporter of ramp
1PC

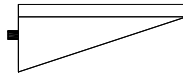

N

Platform
1PC

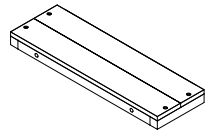

O

Roof
1PC

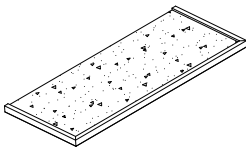

P

Casters without brake
2PCS

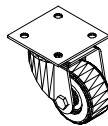

Q

Brake casters
2PCS

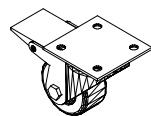

R

PARTS //

Folding metal feeder
1PC

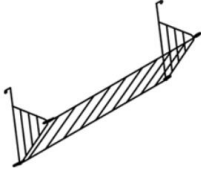

S

PRODUCT ASSEMBLY //

01

Connect the back Part C & D by 5xP6.
Screw the ramp supporter Part N to the down panel Part D by 2xP4.

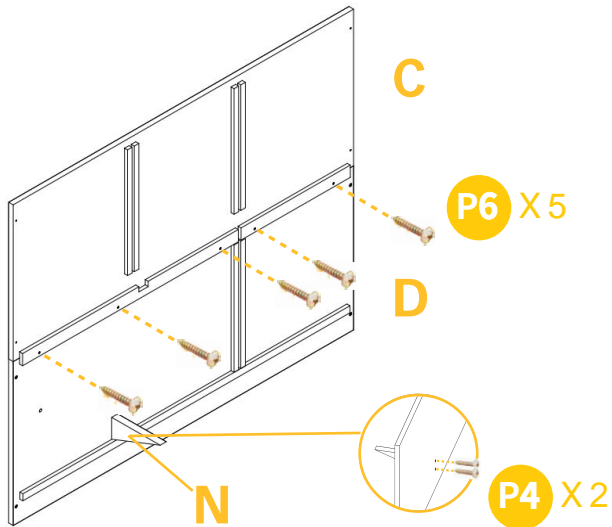

02

Attach the side panel Part E & F to the back by 8xP4.

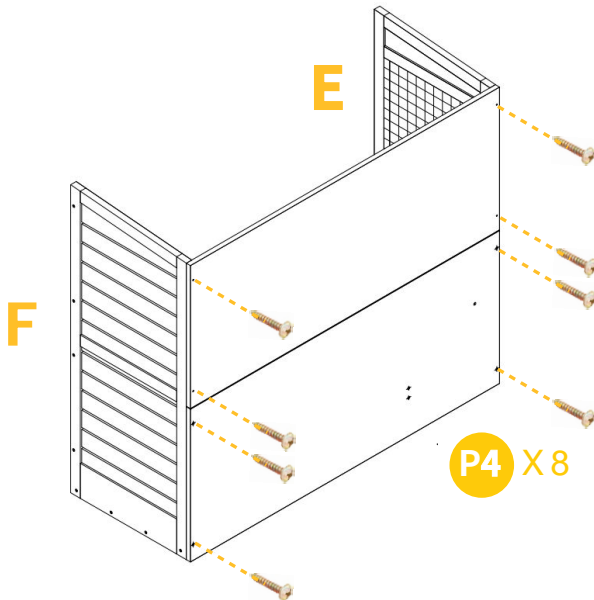

PRODUCT ASSEMBLY //

03 Attach the platform Part O to the left side panel by bolt 2xP1.

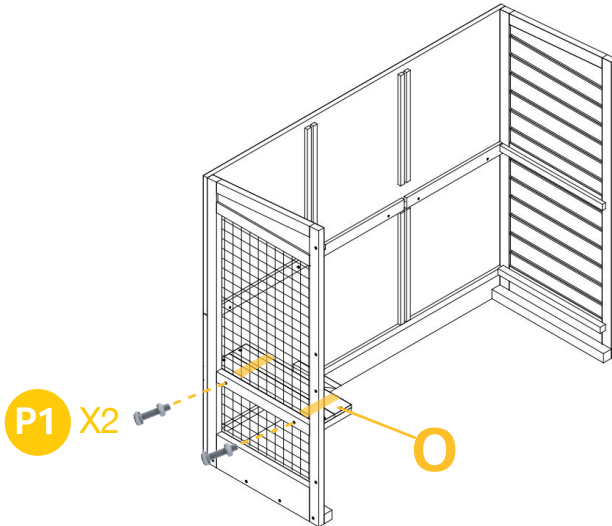

04 Fix the platform from back side by bolt 1xP1.

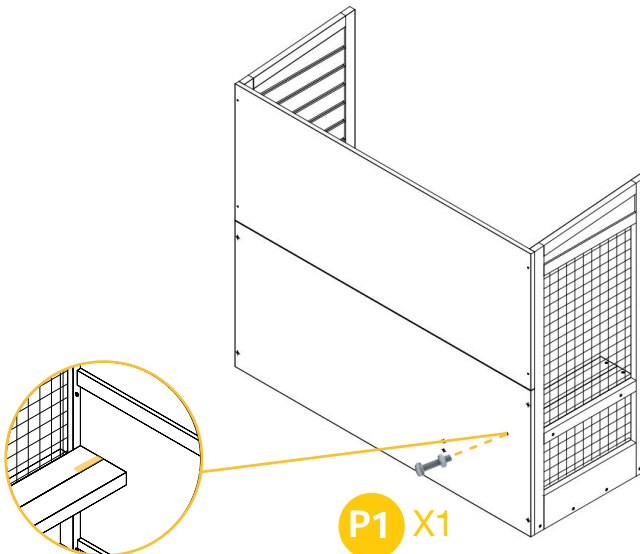

PRODUCT ASSEMBLY

05

Attach the front Part A & B to the sides by 8xP3.
Fix Part A & B by 2xP2.

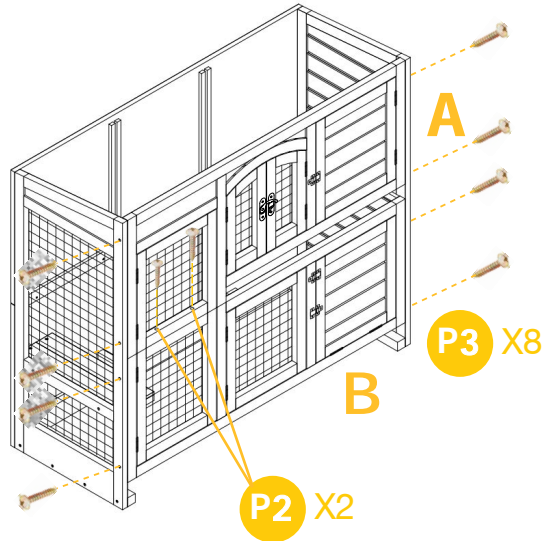

06

Insert the divider Part J to the down level.
Slide in the down plastic tray Part H.

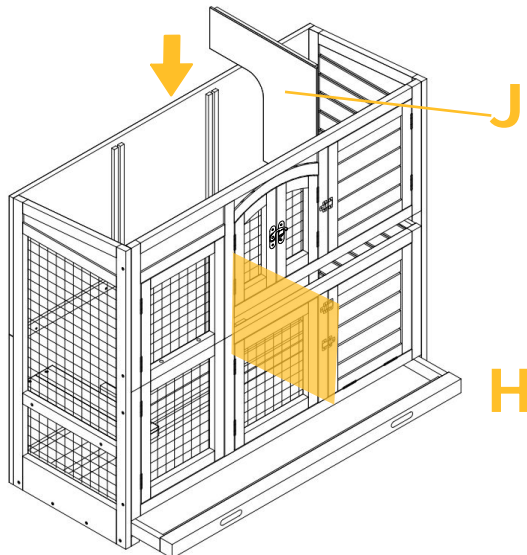

PRODUCT ASSEMBLY //

- 07** Insert the tray supporter Part K to upper layer.
Fix the Part K from front side by 1XP3.
Fix the Part K from back side by 1XP4.
Screw the ramp Part M to the platform by 2xP7.

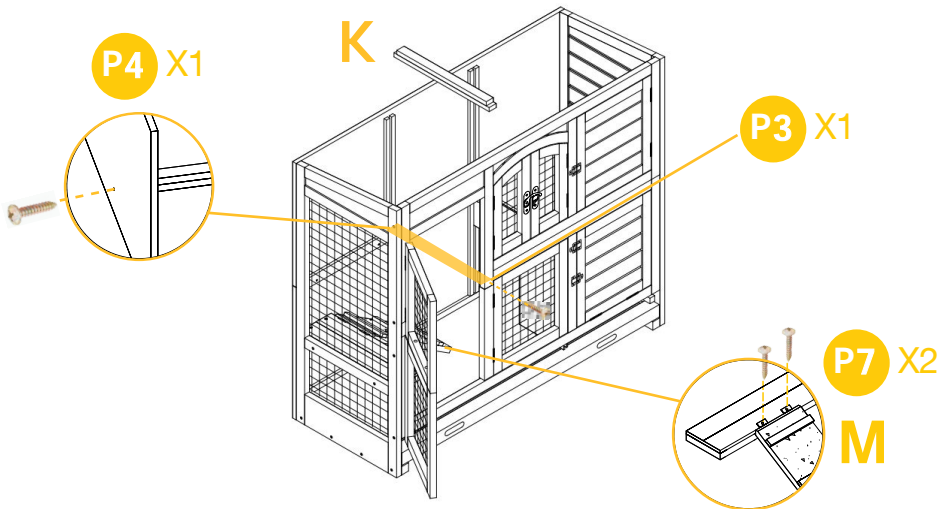

- 08** Insert the dividers Part I to the upper level.
Slide in the upper plastic tray Part G.

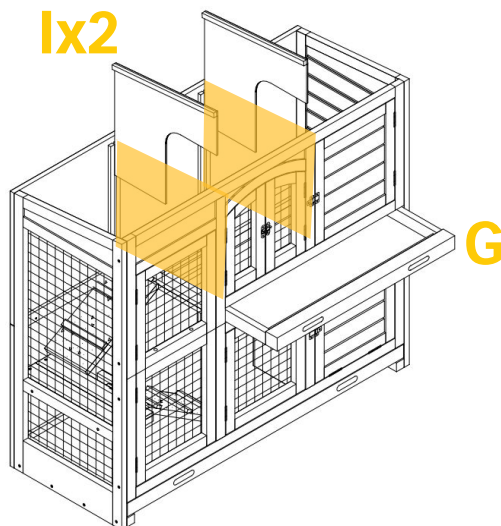

PRODUCT ASSEMBLY //

09

Screw the upper ramp Part L by 2xP7.
Put the chewing toy P10 into the hutch.

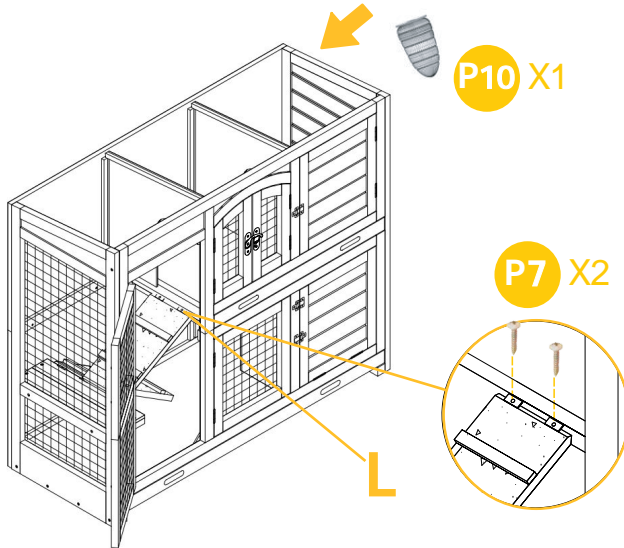

10

Attach the folding metal feeder Part S to the hutch by 2xP8.

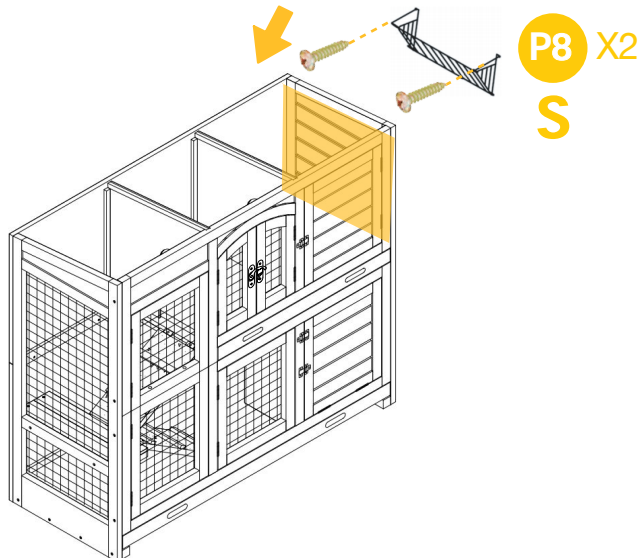

PRODUCT ASSEMBLY //

- 11** Screw two casters without brake Part Q to the front of hutch legs by P5x8.

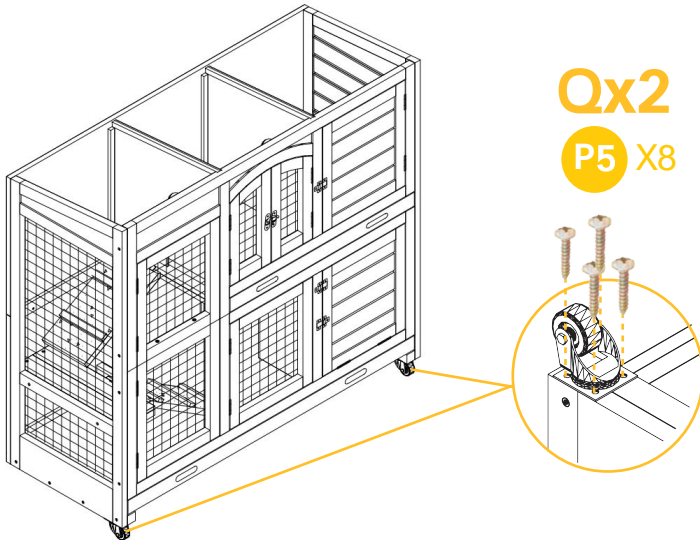

- 12** Screw two brake casters Part R to the back of hutch legs by P5x8.

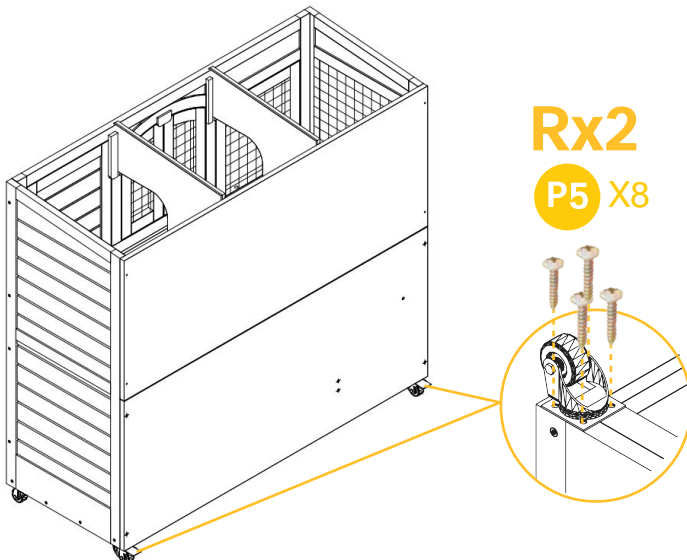

PRODUCT ASSEMBLY //

13 Attach the roof Part P to the hutch by 6xP7.

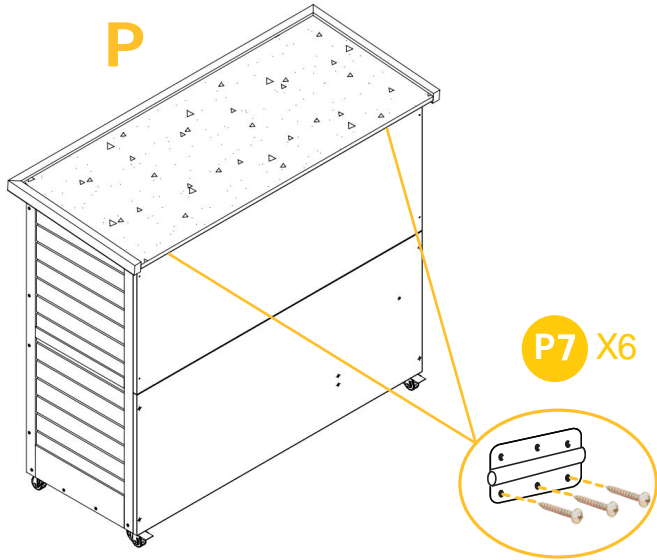

14 Attach the roof hinge P9 with 4xP7 each.
Attach the lock P11 by 4xP12.

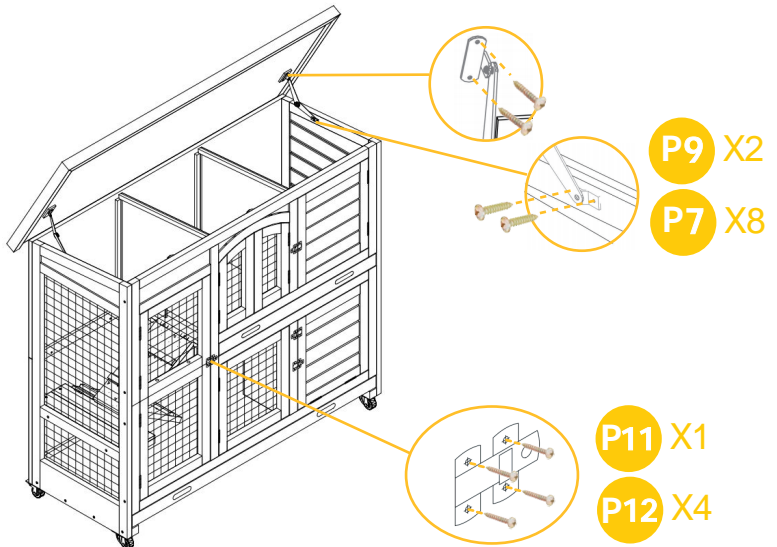



WARNING

Manufacturer and seller expressly disclaim any and all liability for personal injury, property damage or loss, whether direct, indirect, or incidental, resulting from the incorrect attachment, improper use, inadequate maintenance, or neglect of this product.