



Mojave Edition

Made in the USA

8' x 16' Greenhouse Assembly Instructions

220124V 06

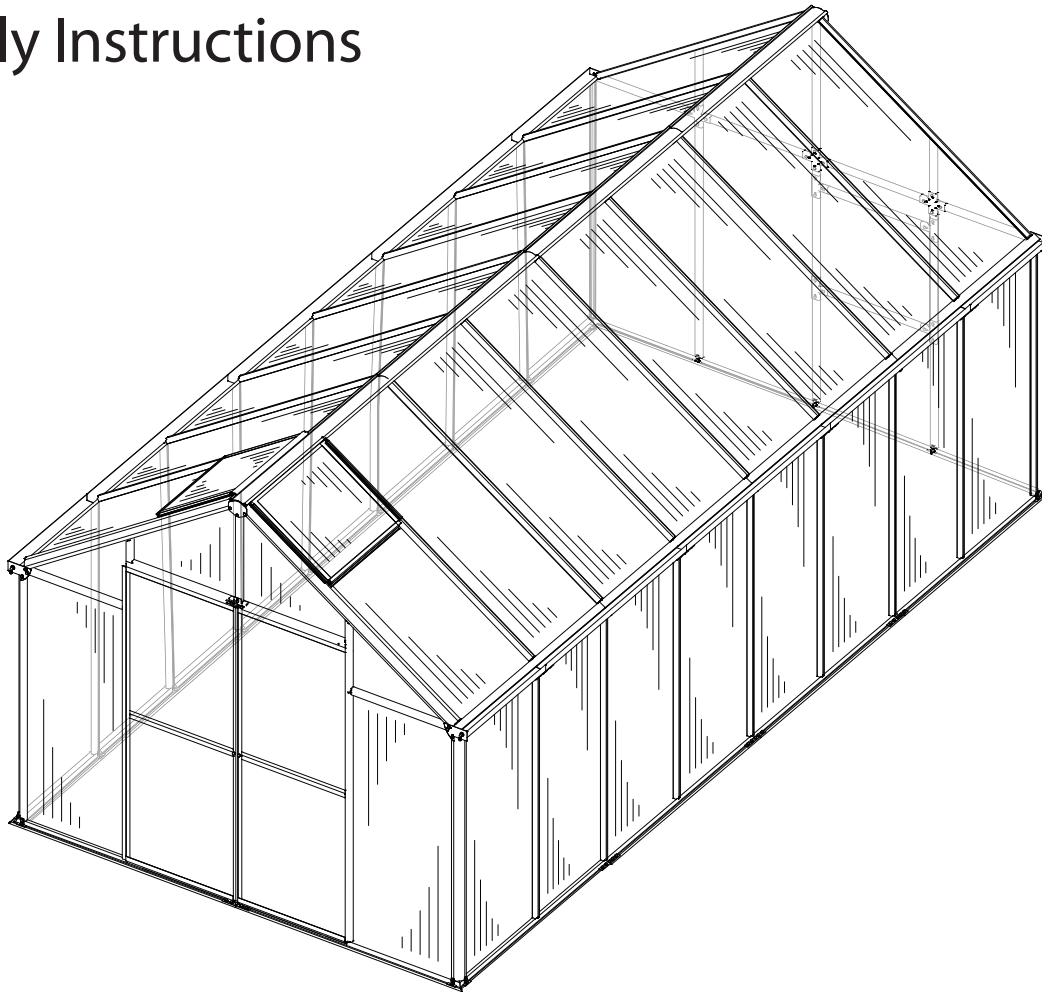

To request missing or lost parts scan this QR code. Valid only within 90 days from date of purchase.



Register Now to receive timely updates, reminders and special offers for your product. Scan the QR code above or go to www.RSIWW.com and select the user registration link.



facebook.com/RiverstoneGreen
twitter.com/@RiverstoneGreen
linkedin.com/company/riverstone-industries
youtube.com/RSIWW



40 Richboynton Rd, Dover, NJ 07801

Customer Service: (877) 373-3078

Email: customerservice@rsiww.com

After Hours Helpline: (443) 574-4764

Thank you for choosing the Mont Greenhouse Program

We want to thank you for your purchase of the Mont Greenhouse. We appreciate your support of our American Made Greenhouses.

The Mont is designed for the average homeowner; no special degrees are needed. The time to assemble depends on the weather, skills, options, and number of helpers you have in the process. All the pieces are cut to size and should fit snug, BUT if something is not working please reach out to our help lines so we can make sure that there are no delays in the process. We are not only employees of Riverstone but owners of Mont Greenhouses and can help you through the process and hopefully keep the frustration levels down if a question comes up.

We would like to take a moment to remind you as the new owner of a Mont Greenhouse a few things to increase the life of your greenhouse.

- Make sure that all your roof vents are closed and tied down with the included bungee balls during high winds. If you cannot pull the vent down because of the pressure on the vent from the cylinder you can remove the silver pin on either bracket by pushing it out with a pen. This would be a 25 mph gusting wind and up. This will help prevent air getting into the Mont and causing damage.
- Like with the roof vents, make sure the dual doors stay closed during winds. The doors are spring loaded to stay closed but we also know that the greenhouse can get rather hot in the warmer months and doors do get propped open. Just make sure that they get closed.
- In cooler snow prone climates, We recommend cutting 2 x 4 's and put them against the roof ridge and the floor to help add support from heavy snow and ice. This should be spaced out every 4 ft inside of the greenhouse. This is just a precaution but could save a lot of aggravation down the road.
- It is also a good practice to clean the snow off the roof. A little snow is fine, but several inches only will tempt fate and it is best to be safe than sorry.
- The polycarbonate panels have channels in them. These are designed to help insulate and in moist environments, like after a rainstorm, you might find water droplets in these channels. It will not cause any harm and will burn itself off when the air starts to heat up.
- In some cases where there is a lot of rainfall, like the Pacific North West, we recommend using clear silicon caulking between the polycarbonate panels and the trim plates before the trim plates are put on. This is just to assure that the Mont stays as dry as possible. Just give a call if you need some more help with this.

Lastly, we are not perfect. We know that there are better ways to do things, we just need some suggestions from our customer base as to what they are. We are always open to feedback, good and bad, and we do react to feedback. Please, if there is an option you do not see that you feel would make the greenhouse experience better, if there is a different way to explain a set-up process, or if there is anything else to help make Mont better we want to hear from you.

Thank you again for your purchase and we hope you have many years of growing in your new Mont Greenhouse.

David Schnurman

Vice President

Merci d'avoir choisi le programme de serre de Mont

Nous voulons vous remercier pour votre achat de la serre Mont. Nous apprécions votre soutien de nos serres américaines.

Le Mont est conçu pour le propriétaire moyen; aucun diplôme spécial n'est nécessaire. Le temps de rassemblement dépend du temps, des compétences, des options et du nombre d'aides que vous avez dans le processus. Toutes les pièces sont coupées à la taille et doivent être bien ajustées, MAIS si quelque chose ne fonctionne pas, veuillez contacter nos lignes d'assistance afin que nous puissions nous assurer qu'il n'y a pas de retard dans le processus. Nous ne sommes pas seulement des employés de Riverstone mais des propriétaires de Serres Mont et nous pouvons vous aider à traverser le processus et, espérons-le, réduire les niveaux de frustration si une question survient.

Nous aimerions prendre un moment pour vous rappeler, en tant que nouveau propriétaire d'une serre Mont, quelques éléments pour augmenter la durée de vie de votre serre.

- Assurez-vous que toutes les fentes d'aération du toit sont fermées et attachées avec les bungee incluses lors de vents violents. Si vous ne parvenez pas à retirer l'évent à cause de la pression exercée sur l'évent par le cylindre, vous pouvez retirer la goupille d'argent de chaque support en la poussant avec un stylo. Ce serait un vent soufflant de 25 mph et plus. Cela aidera à empêcher l'air d'entrer dans le Mont et de causer des dommages.
- Comme avec les événements de toit, assurez-vous que les deux portes restent fermées pendant les vents. Les portes sont à ressort pour rester fermées, mais nous savons aussi que la serre peut devenir plutôt chaude pendant les mois les plus chauds et que les portes peuvent être ouvertes. Assurez-vous simplement qu'ils sont fermés.
- Dans les climats plus froids où il y a de la neige, nous recommandons de couper 2 x 4 et de les poser contre le faîte du toit et le plancher pour aider à supporter le poids de la neige et de la glace. Cela devrait être espacé tous les 4 pieds à l'intérieur de la serre. C'est juste une précaution, mais pourrait sauver beaucoup d'aggravation sur la route.
- C'est aussi une bonne pratique pour nettoyer la neige du toit. Un peu de neige si c'est bien, mais plusieurs centimètres seulement tenteront le destin et il vaut mieux prévenir que guérir.
- Les panneaux de polycarbonate ont des canaux dans eux. Ceux-ci sont conçus pour aider à isoler et dans les environnements humides, comme après une tempête de pluie, vous pourriez trouver des gouttelettes d'eau dans ces canaux. Il ne causera aucun dommage et se brûlera lorsque l'air commencera à chauffer.
- Dans certains cas où il y a beaucoup de pluie, comme dans le Pacifique Nord-Ouest, nous recommandons d'utiliser du calfeutrage au silicone transparent entre les panneaux de polycarbonate et les plaques de garniture avant de mettre les plaques de garniture. C'est juste pour assurer que le Mont reste aussi sec que possible. Appelez simplement si vous avez besoin d'aide supplémentaire.

Enfin, nous ne sommes pas parfaits. Nous savons qu'il existe de meilleures façons de faire les choses, nous avons juste besoin de quelques suggestions de notre clientèle quant à ce qu'ils sont. Nous sommes toujours ouverts à la rétroaction, bonne ou mauvaise, et nous réagissons aux commentaires. S'il vous plaît, s'il y a une option que vous ne voyez pas qui rendrait l'expérience de la serre meilleure, s'il y a une façon différente d'expliquer un processus de mise en place, ou s'il y a autre chose pour améliorer Mont, nous voulons entendre de toi.

Merci encore pour votre achat et nous espérons que vous aurez de nombreuses années de croissance dans votre nouvelle serre Mont.

David Schnurman

Vice President

Gracias por elegir el Programa de Invernadero de Mont

Queremos agradecerle por la compra de Mont Greenhouse. Agradecemos su apoyo a nuestros Invernaderos Americanos.

El Mont está diseñado para el propietario promedio; no se necesitan títulos especiales. El tiempo para reunirse depende del clima, las habilidades, las opciones y la cantidad de ayudantes que tenga en el proceso. Todas las piezas se cortan a la medida y deben ajustarse cómodamente, PERO si algo no funciona, acceda a nuestras líneas de ayuda para asegurarnos de que no haya demoras en el proceso. No solo somos empleados de Riverstone, sino también propietarios de Mont Greenhouses, y podemos ayudarlo a lo largo del proceso y, con suerte, reducir los niveles de frustración si surge una duda.

Nos gustaría tomar un momento para recordarte como el nuevo propietario de un Invernadero de Mont algunas cosas para aumentar la vida de tu invernadero.

- Asegúrese de que todas las rejillas de ventilación del techo estén cerradas y atadas con las bolas elásticas incluidas durante los fuertes vientos. Si no puede tirar de la ventilación hacia abajo debido a la presión en la ventilación del cilindro, puede quitar la clavija plateada de cualquiera de las abrazaderas, empujándola con un rotulador. Esto sería un viento con ráfagas de 25 mph y más. Esto ayudará a evitar que el aire entre en el Mont y cause daños.
- Al igual que con los respiraderos del techo, asegúrese de que las dos puertas permanezcan cerradas durante los vientos. Las puertas están accionadas por resorte para permanecer cerradas, pero también sabemos que el invernadero puede calentarse bastante en los meses más cálidos y las puertas se mantienen abiertas. Solo asegúrate de que se cierren.
- En climas más fríos propensos a la nieve, recomendamos cortar 2 x 4 y colocarlos contra el borde del techo y el piso para ayudar a agregar soporte de nieve y hielo. Esto debe ser espaciado cada 4 pies dentro del invernadero. Esto es solo una precaución, pero podría ahorrar una gran cantidad de agravantes en el camino.
- También es una buena práctica limpiar la nieve del techo. Un poco de nieve si está bien, pero varios centímetros solo tentarán al destino y lo mejor es estar a salvo que lamentar.
- Los paneles de policarbonato tienen canales en ellos. Estos están diseñados para ayudar a aislar y en ambientes húmedos, como después de una tormenta de lluvia, es posible que encuentre gotas de agua en estos canales. No causará ningún daño y se quemará solo cuando el aire comience a calentarse.
- En algunos casos en los que hay mucha lluvia, como el Pacífico Noroeste, recomendamos utilizar un enmasillado de silicona transparente entre los paneles de policarbonato y las placas de acabado antes de colocar las placas de ajuste. Esto es solo para asegurar que el Mont se mantenga lo más seco posible. Simplemente llame si necesita más ayuda con esto.

Por último, no somos perfectos. Sabemos que hay mejores formas de hacer las cosas, solo necesitamos algunas sugerencias de nuestra base de clientes sobre cuáles son. Siempre estamos abiertos a los comentarios, buenos y malos, y reaccionamos a los comentarios. Por favor, si hay una opción que no ve que cree que mejoraría la experiencia del invernadero, si hay una manera diferente de explicar un proceso de configuración, o si hay algo más para ayudar a Mont a mejorar, queremos escuchar de ti.

Gracias de nuevo por su compra y esperamos que tenga muchos años creciendo en su nuevo Mont Greenhouse.

David Schnurman

Vice President

Mont Limited Warranty/ Liability

Snow Load & Wind Load Warranty & Liability

The Mont Greenhouse described in this manual is designed for and limited to Riverstone Industries standard wind and snow load which is based on a continuously heated greenhouse.

Standard loads are: Wind Load = 65 mph continuous winds, Snow load of 24 lbs. sq ft.

Riverstone cannot and will not be held liable or responsible for any and all damages and/or structural failures caused by prevailing load conditions at the greenhouse's erected location that exceed the aforementioned Standard Loads.

All Mont Wind & Snow loads are based on a closed and heated greenhouse structure. The heat provides a source for the snow and ice to melt from the roof. If the Mont is not being heated during the winter months when snow and/ or ice is present it is the owners responsibility to clear the accumulations of the roof.

Contact us directly with any questions regarding this.

Products to which this limited warranty applies:

This limited warranty applies to the following models of your newly purchased Mont Greenhouse: MONT-8, MONT-12, MONT-16, MONT-20, MONT-24, MONT-4; Premium versions, and Mojave Editions of these greenhouses. This limited warranty applies only to purchases made in any province of Canada except for Yukon Territory, Nunavut, or Northwest Territories or in any of the 50 States of the USA (and the District of Columbia) except for Hawaii and Alaska. This limited warranty applies to the original purchaser of the product only and is not transferable.

What this limited warranty covers and for how long:

Products covered by this limited warranty have been tested and inspected prior to shipment and, subject to the provisions of this warranty, Riverstone Industries warrants such products to be free from defects in material and workmanship for a period of 1 year from the date of the first purchase of such products.

The limited 10-year warranty period is for the greenhouse structure only. Warranty for accessories vary. Some jurisdictions do not allow limitations on how long an implied warranty lasts, so the above limitation may not apply to the purchaser.

The limited warranty for accessories follows the same guidelines as above and is covered for the following time span.

- Work Bench System – 10 years
- Watering System – 7 years
- Shade Cloth System – 7 years
- Garden/ Potting Sink – 3 years
- Automatic Opener Liquid Filled Piston – 2 years
- For warranty information on other accessories please contact Riverstone.

What this limited warranty does not cover:

This limited warranty does not apply to products that have been repaired (except by Riverstone Industries or its authorized service representatives) or otherwise altered. This limited warranty does further not apply to defects resulting from misuse, abuse, accident, neglect, incorrect installation, improper maintenance or handling, or operation with an incorrect power source.

Riverstone Industries is not responsible for personal time lost, or paid for, during the construction of its products, due to missing or defective parts. Riverstone will replace lost or missing parts up to 90 days from date of purchase. After 90 days "no cost replacement" is at the discretion of Riverstone.

What you must do to get service under this limited warranty:

Defects must be brought to the attention of Riverstone Industries Technical Service by contacting Riverstone Industries at customerservice@RSIWW.com or 612-RVR-STNE (787-7863). Please have proof of purchase, catalog/model and serial numbers available when calling. Limited warranty service requires a proof of purchase of the product.

What Riverstone Industries will do in the event of a defect:

In the event a product or part covered by this limited warranty is proven to be defective in material or workmanship during the 10-year limited warranty period for products, you have the following rights:

Riverstone Industries will in its sole discretion either repair or replace such defective product or part without charge. If Riverstone Industries is unable to repair or replace such product or part, or if repair or replacement is not commercially practicable or cannot be timely made, Riverstone Industries may, in lieu of repair or replacement, choose to refund the purchase price for such product or part.

Limited warranty service will be performed solely by dealers or service agents of Riverstone Industries authorized to provide limited warranty services.

Garantie limitée Mont/responsabilité

Charge de neige et charge de vent Garantie et responsabilité

La serre du Mont décrite dans ce manuel est conçue et limitée à la charge de vent et de neige standard de Riverstone Industries qui est basée sur une serre chauffée en continu.

Les charges standard sont les suivantes : Charge éolienne = vents continus de 65 mi/h, charge de neige de 24 lb pieds carrés.

Riverstone ne peut et ne sera pas tenu responsable de tous les dommages et/ou défaillances structurelles causés par les conditions de charge dominantes à l'emplacement érigé de la serre qui dépassent les charges standard susmentionnées.

Toutes les charges Mont Wind & Snow sont basées sur une structure de serre fermée et chauffée. La chaleur fournit une source de fonte de la neige et de la glace du toit. Si le Mont n'est pas chauffé pendant les mois d'hiver en présence de neige et/ou de glace, il incombe aux propriétaires de dégager les accumulations du toit.

Contactez-nous directement pour toute question à ce sujet.

Produits auxquels cette garantie limitée s'applique:

Cette garantie limitée s'applique aux modèles suivants de votre nouvelle serre Mont : MONT-8, MONT-12, MONT-16, MONT-20, MONT-24, MONT-4 ; versions Premium et éditions Mojave de ces serres. Cette garantie limitée ne s'applique qu'aux achats effectués dans n'importe quelle province du Canada, à l'exception du Yukon, du Nunavut ou des Territoires du Nord-Ouest ou dans l'un des 50 États des États-Unis (et du district de Columbia), à l'exception d'Hawaï et de l'Alaska. Cette garantie limitée s'applique uniquement à l'acheteur initial du produit et n'est pas transférable.

Ce que couvre cette garantie limitée et pendant combien de temps:

Les produits couverts par cette garantie limitée ont été testés et inspectés avant l'expédition et, sous réserve des dispositions de cette garantie, Riverstone Industries garantit que ces produits sont exempts de défauts de matériau et de fabrication pendant une période d'un an à compter de la date du premier achat de ces produits.

La période de garantie limitée de 10 ans s'applique uniquement à la structure de la serre. La garantie des accessoires varie. Certaines juridictions n'autorisent pas les limitations sur la durée d'une garantie implicite, de sorte que la limitation ci-dessus peut ne pas s'appliquer à l'acheteur.

La garantie limitée pour les accessoires suit les mêmes directives que ci-dessus et est couverte pour la période suivante.

- Système d'établi de travail - 10 ans
- Système d'arrosage - 7 ans
- Système de tissus d'ombrage - 7 ans
- Évier de jardin/potage - 3 ans
- Ouvreur automatique à piston rempli de liquide – 2 ans
- Pour plus d'informations sur la garantie d'autres accessoires, veuillez contacter Riverstone.

Ce que cette garantie limitée ne couvre pas:

Cette garantie limitée ne s'applique pas aux produits qui ont été réparés (sauf par Riverstone Industries ou ses représentants de service autorisés) ou autrement modifiés. Cette garantie limitée ne s'applique pas non plus aux défauts résultant d'une mauvaise utilisation, d'un abus, d'un accident, d'une négligence, d'une installation incorrecte, d'un entretien ou d'une mauvaise manipulation, ou d'un fonctionnement avec une source d'alimentation incorrecte.

Riverstone Industries n'est pas responsable du temps personnel perdu ou payé pendant la construction de ses produits, en raison de pièces manquantes ou défectueuses. Riverstone remplacera les pièces perdues ou manquantes jusqu'à 90 jours à compter de la date d'achat. Après 90 jours, « aucun remplacement des coûts » est à la discrétion de Riverstone.

Ce que vous devez faire pour obtenir une réparation en vertu de cette garantie limitée:

Les défauts doivent être portés à l'attention du service technique de Riverstone Industries en contactant Riverstone Industries à customerservice@RSIWW.com ou au 612-RVR-STNE (787-7863). Veuillez avoir une preuve d'achat, un catalogue/modèle et des numéros de série disponibles lors de l'appel. Le service de garantie limitée nécessite une preuve d'achat du produit.

Ce que Riverstone Industries fera en cas de défaut:

Dans le cas où un produit ou une pièce couvert par cette garantie limitée s'avère défectueux en matériau ou en fabrication au cours de la période de garantie limitée de 10 ans pour les produits, vous avez les droits suivants:

Riverstone Industries réparera ou remplacera sans frais, à sa seule discrétion, ce produit ou cette pièce défectueux. Si Riverstone Industries n'est pas en mesure de réparer ou de remplacer ce produit ou cette pièce, ou si la réparation ou le remplacement n'est pas commercialisable ou ne peut pas être effectué en temps opportun, Riverstone Industries peut, au lieu de la réparation ou du remplacement, choisir de rembourser le prix d'achat de ce produit ou de cette pièce.

Le service de garantie limitée sera effectué uniquement par des concessionnaires ou des agents de service de Riverstone Industries autorisés à fournir des services de garantie limitée.

Garantía limitada/responsabilidad de Mont

Garantía y responsabilidad de carga de nieve y viento

El Invernadero Mont descrito en este manual está diseñado y limitado a la carga estándar de viento y nieve de Riverstone Industries, que se basa en un invernadero continuamente calentado.

Las cargas estándar son: Carga de viento = vientos continuos de 65 mph, carga de nieve de 24 libras de pies cuadrados.

Riverstone no puede ni será responsable de todos y cada uno de los daños y/o fallas estructurales causadas por las condiciones de carga prevalecientes en la ubicación erigida del invernadero que excedan las cargas estándar antes mencionadas.

Todas las cargas de viento y nieve del Mont se basan en una estructura de invernadero cerrada y climatizada. El calor proporciona una fuente para que la nieve y el hielo se derritan del techo. Si el Mont no se calienta durante los meses de invierno cuando hay nieve y/o hielo, es responsabilidad de los propietarios limpiar las acumulaciones del techo.

Póngase en contacto con nosotros directamente con cualquier pregunta al respecto.

Productos a los que se aplica esta garantía limitada:

Esta garantía limitada se aplica a los siguientes modelos de su recién comprado Mont Greenhouse: MONT-8, MONT-12, MONT-16, MONT-20, MONT-24, MONT-4; versiones Premium y ediciones Mojave de estos invernaderos. Esta garantía limitada se aplica solo a las compras realizadas en cualquier provincia de Canadá, excepto en el Territorio del Yukón, Nunavut o Territorios del Noroeste o en cualquiera de los 50 estados de los Estados Unidos (y el Distrito de Columbia), excepto Hawái y Alaska. Esta garantía limitada se aplica solo al comprador original del producto y no es transferible.

Qué cubre esta garantía limitada y durante cuánto tiempo:

Los productos cubiertos por esta garantía limitada han sido probados e inspeccionados antes del envío y, sujeto a las disposiciones de esta garantía, Riverstone Industries garantiza que dichos productos estén libres de defectos de material y mano de obra durante un período de 1 año a partir de la fecha de la primera compra de dichos productos.

El período de garantía limitada de 10 años es solo para la estructura del invernadero. La garantía de los accesorios varía. Algunas jurisdicciones no permiten limitaciones sobre la duración de una garantía implícita, por lo que es posible que la limitación anterior no se aplique al comprador.

La garantía limitada para los accesorios sigue las mismas pautas que las anteriores y está cubierta durante el siguiente período de tiempo.

- Sistema de banco de trabajo - 10 años
- Sistema de riego - 7 años
- Sistema de tela de sombra - 7 años
- Fregadero de jardín/ollas - 3 años
- Pistón lleno de líquido del abridor automático - 2 años
- Para obtener información sobre la garantía de otros accesorios, comuníquese con Riverstone.

Lo que esta garantía limitada no cubre:

Esta garantía limitada no se aplica a los productos que han sido reparados (excepto por Riverstone Industries o sus representantes de servicio autorizados) o alterados de otra manera. Esta garantía limitada tampoco se aplica a los defectos resultantes del mal uso, abuso, accidente, negligencia, instalación incorrecta, mantenimiento o manejo inadecuados u operación con una fuente de energía incorrecta.

Riverstone Industries no se hace responsable del tiempo personal perdido o pagado durante la construcción de sus productos, debido a piezas faltantes o defectuosas. Riverstone reemplazará las piezas perdidas o faltantes hasta 90 días a partir de la fecha de compra. Después de 90 días, "sin reemplazo de costos" queda a discreción de Riverstone.

Lo que debe hacer para obtener servicio bajo esta garantía limitada:

Los defectos deben señalarse a la atención del Servicio Técnico de Riverstone Industries poniéndose en contacto con Riverstone Industries en customerservice@RSIWW.com o 612-RVR-STNE (787-7863). Tenga comprobante de compra, catálogo/modelo y números de serie disponibles al llamar. El servicio de garantía limitada requiere un comprobante de compra del producto.

Qué hará Riverstone Industries en caso de defecto:

En el caso de que se demuestre que un producto o pieza cubierta por esta garantía limitada es defectuoso en material o mano de obra durante el período de garantía limitada de 10 años para los productos, usted tiene los siguientes derechos:

Riverstone Industries, a su entera discreción, reparará o reemplazará dicho producto o pieza defectuoso sin cargo. Si Riverstone Industries no puede reparar o reemplazar dicho producto o pieza, o si la reparación o el reemplazo no son comercialmente viables o no se pueden realizar a tiempo, Riverstone Industries puede, en lugar de reparación o reemplazo, optar por reembolsar el precio de compra de dicho producto o pieza.

El servicio de garantía limitada será realizado únicamente por distribuidores o agentes de servicio de Riverstone Industries autorizados para proporcionar servicios de garantía limitada.

Dispute Resolution Jurisdictional Limitations and Procedures:

It is agreed that all transactions involving Riverstone Industries products originate and occur within the State of New Jersey. As a condition of the purchase, service, repair or replacement of any Riverstone Industries product, all matters, including but not limited to any dispute arising out of the purchase, service, repair or replacement of any Riverstone Industries product, shall be determined by arbitration with jurisdiction and venue agreed to be in the State of New Jersey, County of Morris. Arbitration shall proceed in accordance with the Rules of the American Arbitration Association (or its successor then existing) by a panel of three arbitrators with the non-prevailing party responsible for all legal fees and expenses. The determination in such arbitration proceeding shall be conclusive upon the parties, and judgment upon any award or decision may be entered in any court having jurisdiction thereof, as further set forth below. The costs, fees, and expenses of the arbitrator or arbitrators, and/or the American Arbitration Association shall be shared equally by the parties thereto unless otherwise provided in the arbitrators' decision.

- **JURISDICTION AND WAIVER OF TRIAL BY JURY.** IT IS MUTUALLY AGREED BY AND BETWEEN THE PARTIES THAT THEY AGREE TO THE SUPERIOR COURT OF NEW JERSEY, MORRIS COUNTY AS THE JURISDICTION AND VENUE FOR ALL LEGAL PROCEEDINGS AND THEY FURTHER HEREBY DO WAIVE TRIAL BY JURY IN ANY ACTION, PROCEEDING OR COUNTERCLAIM BROUGHT BY EITHER OF THE PARTIES HERETO AGAINST THE OTHER ON ANY MATTERS WHATSOEVER ARISING OUT OR IN ANY WAY CONNECTED WITH THE PURCHASE, SERVICE, REPAIR OR REPLACEMENT OF ANY RIVERSTONE INDUSTRIES PRODUCT.
- **NO WAIVERS.**
 - Any failure of Riverstone Industries to enforce any remedy allowed for shall not imply the waiver of any such provision, even if such violation is continued or repeated, and no express waiver shall affect any provision other than the one(s) specified in such waiver and only for the time and in the manner specifically stated.
 - No delay on the part of Riverstone Industries in exercising any right, power or privilege hereunder or to seek redress for violation of, or to insist upon strict performance of any covenant or condition of this Warranty, shall operate as a waiver thereof nor shall any single or partial exercise of any right, power or privilege preclude any other or further exercise thereof or the exercise of any other right, power or privilege.
 - No act done or thing said by Riverstone Industries or its agents shall constitute a cancellation, termination or modification of, or surrender under, this Warranty, or a waiver of any covenant, condition or provision hereof, nor relieve the customer of any obligation hereunder. Any acceptance of surrender, waiver or release by Riverstone Industries and any cancellation, termination or modification of this Warranty must be in writing signed by a duly authorized officer of Riverstone Industries.

Règlement des différends Limites et procédures juridictionnelles

Il est convenu que toutes les transactions impliquant des produits Riverstone Industries proviennent et se produisent dans l'État du New Jersey. Comme condition d'achat, d'entretien, de réparation ou de remplacement de tout produit de Riverstone Industries, toutes les questions, y compris mais sans s'y limiter, tout litige découlant de l'achat, du service, de la réparation ou du remplacement de tout produit de Riverstone Industries, seront déterminées par arbitrage. avec juridiction et lieu convenu d'être dans l'État du New Jersey, comté de Morris. L'arbitrage doit se dérouler conformément aux Règles de l'American Arbitration Association (ou son successeur alors existant) par un panel de trois arbitres avec la partie non-prévalante responsable de tous les frais juridiques et les dépenses. La détermination dans une telle procédure d'arbitrage sera concluante pour les parties, et le jugement sur toute sentence ou décision pourra être porté devant tout tribunal compétent, tel qu'indiqué ci-dessous. Les frais, honoraires et dépenses de l'arbitre ou des arbitres et / ou de l'American Arbitration Association seront partagés également entre les parties, à moins que la décision des arbitres n'en dispose autrement.

1. **JURIDICTION ET RENONCIATION AU PROCÈS PAR JURY.** IL EST MUTUELLEMENT AGRÉÉ PAR ET ENTRE LES PARTIES QU'ILS SONT D'ACCORD AVEC LA COUR SUPÉRIEURE DU NEW JERSEY, LE COMTÉ DE MORRIS EN TANT QUE JURIDICTION ET LIEU POUR TOUTE PROCÉDURE JUDICIAIRE, ET QU'ILS FERONT PAR LA PRÉSENTE RENONCER AU PROCÈS, AU RECOURS OU À L'INVOQUATION DE L'UN OU L'AUTRE LES PARTIES CONTRE L'AUTRE SUR TOUTE QUESTION QUI DÉCOULE OU QUEL QU'ELLE SOIT RELIÉE À L'ACHAT, AU SERVICE, À LA RÉPARATION OU AU REMPLACEMENT DE TOUT PRODUIT DE L'INDUSTRIE RIVERSTONE.
2. **AUCUNE RENONCIATION.**
 - A. Tout défaut de Riverstone Industries de faire valoir un recours autorisé n'implique pas la renonciation à une telle disposition, même si cette violation est continuée ou répétée, et aucune renonciation expresse n'affectera une disposition autre que celle (s) spécifiée (s) renonciation et seulement pour le temps et de la manière spécifiquement indiquée.
 - B. Aucun retard de la part de Riverstone Industries dans l'exercice de tout droit, pouvoir ou privilège ci-dessous ou pour demander réparation pour violation de, ou pour insister sur l'exécution stricte de toute convention ou condition de cette Garantie, agira comme une renonciation de celle-ci ni l'exercice, simple ou partiel, de tout droit, pouvoir ou privilège exclut tout autre exercice, tout exercice ultérieur ou tout autre droit, pouvoir ou privilège.
 - C. Aucun acte ou chose fait par Riverstone Industries ou ses agents ne constitue une annulation, une résiliation ou une modification de, ou une renonciation en vertu de cette garantie, ou une renonciation à toute clause, condition ou disposition des présentes, ni dégager le client de toute obligation ci-dessous. Toute acceptation de la renonciation, de la renonciation ou de la mainlevée par Riverstone Industries et toute annulation, résiliation ou modification de cette garantie doit être faite par écrit et signée par un agent dûment autorisé de Riverstone Industries.

Resolución de disputas Limitaciones y procedimientos jurisdiccionales:

Se acuerda que todas las transacciones que involucran productos de Riverstone Industries se originan y ocurren dentro del Estado de Nueva Jersey. Como condición de la compra, servicio, reparación o reemplazo de cualquier producto de Riverstone Industries, todos los asuntos, incluidos, entre otros, cualquier disputa que surja de la compra, servicio, reparación o reemplazo de cualquier producto de Riverstone Industries, se determinarán mediante arbitraje. Con jurisdicción y lugar de acuerdo en estar en el Estado de New Jersey, Condado de Morris. El arbitraje se llevará a cabo de acuerdo con las Reglas de la Asociación de Arbitraje de América (o su sucesor existente en ese momento) por un panel de tres árbitros con la parte no dominante responsable de todos los honorarios y gastos legales. La determinación en dicho procedimiento de arbitraje será concluyente para las partes, y el juicio sobre cualquier adjudicación o decisión podrá ser ingresado en cualquier tribunal que tenga jurisdicción sobre el mismo, tal como se detalla a continuación. Los costos, honorarios y gastos del árbitro o árbitros, y / o la Asociación Americana de Arbitraje serán compartidos equitativamente por las partes a menos que se disponga lo contrario en la decisión de los árbitros.

1. **JURISDICCIÓN Y EXENCIÓN DE JUICIO POR JURADO.** ES MUTUAMENTE AGREGADO POR Y ENTRE LAS PARTES QUE ESTÁN DE ACUERDO CON EL TRIBUNAL SUPERIOR DE NEW JERSEY, EL CONDADO DE MORRIS COMO JURISDICCIÓN Y LUGAR DE TODOS LOS PROCEDIMIENTOS JURÍDICOS, Y ADEMÁS RENUNCIAN AL JUICIO POR JURADO EN CUALQUIER ACCIÓN, PROCEDIMIENTO O CONTRARENCIACIÓN PRESENTADOS POR CUALQUIERA DE LAS PARTES HERETO CONTRA LA OTRA EN CUALQUIER ASUNTO QUE SE PRODUZCA O SE RELACIONE DE ALGUNA MANERA CON LA COMPRA, SERVICIO, REPARACIÓN O REEMPLAZO DE CUALQUIER PRODUCTO DE RIVERSTONE INDUSTRIES.

2. **NO EXISTE.**

- A. Cualquier falla de Riverstone Industries para hacer cumplir cualquier remedio permitido no implicará la renuncia a tal disposición, incluso si dicha violación se continúa o se repite, y ninguna renuncia expresa afectará ninguna disposición que no sea la (s) especificada (s) en tal exención y solo por el tiempo y en la forma especificada.
- B. Ninguna demora por parte de Riverstone Industries en el ejercicio de ningún derecho, poder o privilegio en virtud del presente o para buscar reparación por violación o para insistir en el cumplimiento estricto de cualquier convenio o condición de esta Garantía, operará como una renuncia a la misma ni deberá cualquier ejercicio único o parcial de cualquier derecho, poder o privilegio excluye cualquier otro o posterior ejercicio del mismo o el ejercicio de cualquier otro derecho, poder o privilegio.
- C. Ningún acto hecho o cosa indicada por Riverstone Industries o sus agentes constituirá una cancelación, terminación o modificación de, o se entregará bajo esta Garantía, o una renuncia a cualquier pacto, condición o disposición de la misma, ni liberará al cliente de ninguna obligación a continuación. Cualquier aceptación de rendición, renuncia o liberación por parte de Riverstone Industries y cualquier cancelación, finalización o modificación de esta Garantía debe hacerse por escrito y firmada por un funcionario debidamente autorizado de Riverstone Industries.

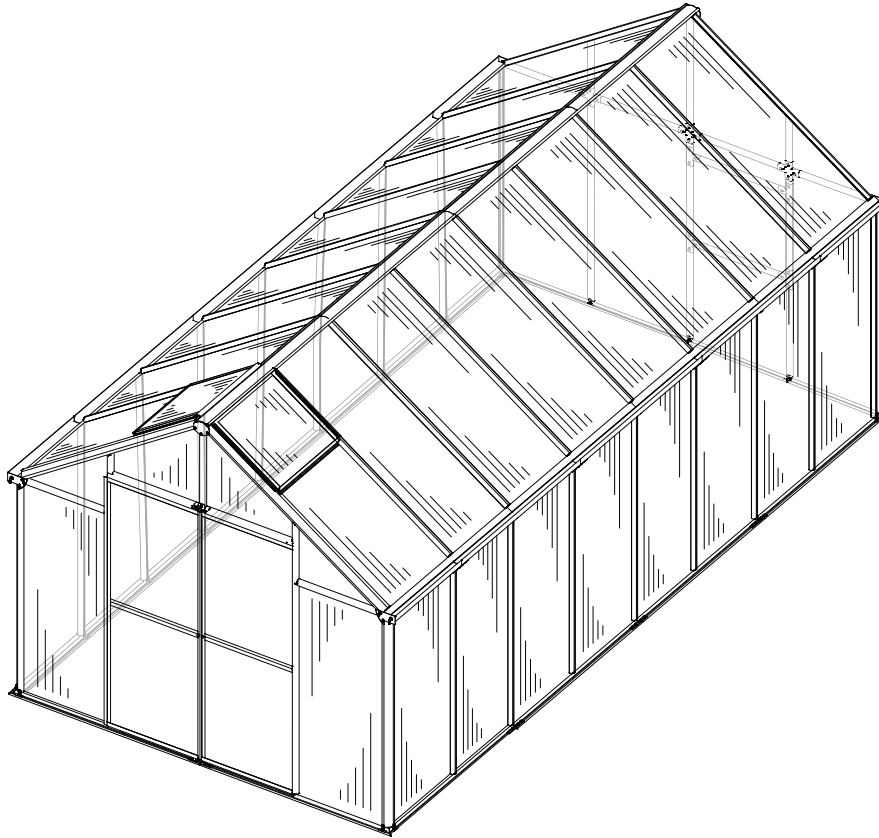

Introduction

Thank you for purchasing the Mont™ Greenhouse. The Mont line is proudly made in the USA using professional grade materials and designs. The frame is constructed with the highest quality extruded aluminum with lead free powder-coated paint. The panels are professional grade 8mm twin wall polycarbonate selected for their insulation and durability.

The List of Parts has the corresponding step number referenced to each part so you can easily prepare for each step. We recommend placing all parts in one staging area. Lay out parts by size and shape. Use the List of Parts to identify the part numbers for profiles and panels. We have not labeled the parts with stickers to avoid removing them during assembly.

Our greenhouse has been designed to be easily assembled. Although all but one step can be completed by one person, we recommend using a helper for the entire assembly. You will need assistance from another person to assemble the roof. If you have never assembled a greenhouse before, make it a weekend project. We recommend you take your time and read these instructions carefully to avoid mistakes.

NOTE: These instructions include helpful hints and important information needed to safely assemble and properly maintain the greenhouse. Please read these instructions completely before you begin.

Please send us photos of your new greenhouse to post on the Riverstone website.
Contact us with questions at Customer Service: (877) 373-3078
Email: customerservice@rsiww.com After Hours Helpline: (443) 574-4764



CAREFULLY READ ALL INSTRUCTIONS BEFORE YOU BEGIN.
FOLLOW STEPS IN THE ORDER PRESENTED. KEEP THIS MANUAL FOR FUTURE REFERENCE.

Several Days Before Starting Assembly:

1. Make sure you have all the necessary parts:

Compare the contents of the cartons with the List of Parts. If any parts are missing or damaged, contact Riverstone Customer Service several days before beginning assembly so there will be time to get you the missing/replacement parts without holding up the assembly process. During business hours call (877) 373-3078, email: customerservice@rsiww.com or use the After Hours Helpline: (443) 574-4764.

2. Lay the parts out in one staging area:

The List of Parts has the corresponding step number referenced to each part so you can easily prepare for each step. We recommend placing all parts in one staging area. Lay out parts by size and shape. Use the List of Parts to identify the part numbers for profiles and panels. We have not labeled the parts with stickers to avoid removing them during assembly. Check very closely that you have the required number of parts for each step.

3. Select a Location:

When selecting a site for your greenhouse, a flat level surface is essential and if possible, with proper water drainage and easy access to power and water necessary for greenhouse gardening. Choose a sunny, level position away from overhanging trees and power lines and protected from the wind as much as possible. The location should be away from structures that could cause snow to drift on or around the greenhouse. Locate underground pipes or cables before preparing the site or anchoring the greenhouse.

4. Prepare a Foundation:

After choosing a location, proper preparation of the site is essential. The site must be level. The greenhouse must be mounted to a base. Construct the base first so the greenhouse can be securely mounted. We recommend constructing a wood platform base using a perimeter of two by fours filled with either soil, sod or gravel. Instructions for constructing a wood platform can be found in this manual.

Other suitable base options include wood decks and concrete slabs. Wood screws are included to secure the greenhouse to a wood base. The greenhouse is secured to the ground from the inside with ground anchors. See step 11 for details. If you are using a concrete base, get appropriate mounting screws before beginning.

Make sure the corners are square by measuring the inside diagonals from both sides and making sure they are equal. Use a spirit level to make sure the base is level.

Contact your local authorities regarding any required building permits or restrictions.

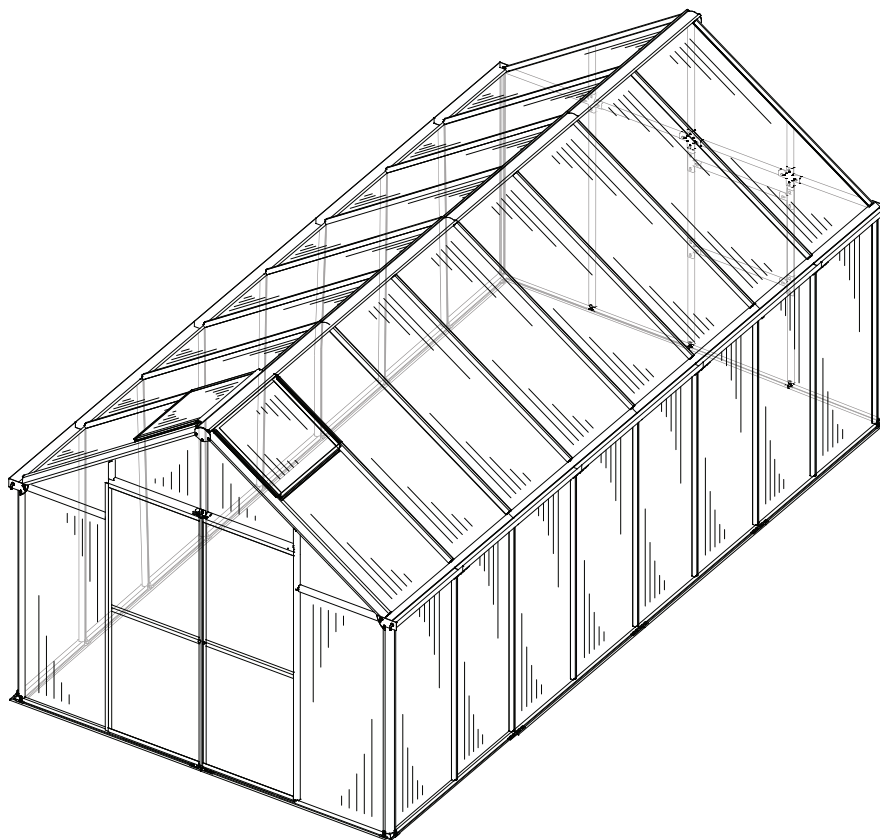

l' introduction

Merci d'avoir acheté la Serre Mont™. La ligne Mont est fièrement fabriquée aux États-Unis en utilisant des matériaux et des conceptions de qualité professionnelle. Le cadre est construit avec de l'aluminium extrudé de la plus haute qualité avec une peinture en poudre sans plomb. Les panneaux sont en polycarbonate à double paroi de 8 mm de qualité professionnelle sélectionné pour leur isolation et leur durabilité.

La liste des pièces a le numéro d'étape correspondant référencé à chaque pièce afin que vous puissiez facilement vous préparer pour chaque étape. Nous vous recommandons de placer toutes les pièces dans une zone de transit. Disposez les pièces par taille et par forme. Utilisez la liste des pièces pour identifier les références des profilés et des panneaux. Nous n'avons pas étiqueté les pièces avec des autocollants pour éviter de les enlever lors du montage.

Notre serre a été conçue pour être facilement assemblée. Bien que toutes les étapes sauf une puissent être effectuées par une seule personne, nous vous recommandons d'utiliser un assistant pour l'ensemble de l'assemblage. Vous aurez besoin de l'aide d'une autre personne pour assembler le toit. Si vous n'avez jamais assemblé de serre auparavant, faites-en un projet de week-end. Nous vous recommandons de prendre votre temps et de lire attentivement ces instructions pour éviter les erreurs.

REMARQUE : Ces instructions comprennent des conseils utiles et des informations importantes nécessaires pour assembler en toute sécurité et entretenir correctement la serre. Veuillez lire complètement ces instructions avant de commencer.

Veillez nous envoyer des photos de votre nouvelle serre à publier sur le site Web de Riverstone.
Contactez-nous avec des questions au service à la clientèle : (877) 373-3078
Courriel : customerservice@rsiww.com Assistance téléphonique après les heures d'ouverture : (443) 574-4764



LISEZ ATTENTIVEMENT TOUTES LES INSTRUCTIONS AVANT DE COMMENCER.
SUIVEZ LES ÉTAPES DE L'ORDRE PRÉSENTÉ. CONSERVER CE MANUEL POUR RÉFÉRENCE FUTURE.

Plusieurs jours avant de commencer l'assemblage:

1. Assurez-vous d'avoir toutes les pièces nécessaires:

Comparez le contenu des cartons avec la liste des pièces. S'il manque des pièces ou endommagé, contactez le service client Riverstone plusieurs jours avant de commencer l'assemblage afin que vous ayez le temps de vous procurer les pièces manquantes/de remplacement sans retarder le processus d'assemblage. Pendant les heures d'ouverture, appelez le (877) 373-3078, email: customerservice@rsiww.com ou utilisez la ligne d'assistance après les heures: (443) 574-4764.

2. Disposez les pièces dans une zone de préparation:

La liste des pièces a le numéro d'étape correspondant référencé à chaque pièce afin que vous puissiez facilement vous préparer pour chaque étape. Nous vous recommandons de placer toutes les pièces dans une zone de transit. Disposez les pièces par taille et par forme. Utilisez la liste des pièces pour identifier les références des profilés et des panneaux. Nous n'avons pas étiqueté les pièces avec des autocollants pour éviter de les enlever lors du montage. Vérifiez de très près que vous disposez du nombre de pièces requis pour chaque étape.

3. Sélectionnez un emplacement:

Lors de la sélection d'un site pour votre serre, une surface plane est essentielle et, si possible, avec un bon drainage de l'eau et un accès facile à l'électricité et à l'eau nécessaires pour le jardinage en serre. Choisissez une position ensoleillée et plane loin des surplombs arbres et lignes électriques et protégés du vent autant que possible. L'emplacement doit être éloigné des structures qui pourraient faire dériver la neige sur ou autour de la serre. Repérez les tuyaux ou les câbles souterrains avant de préparer le site ou d'ancrer la serre.

4. Préparez une fondation:

Après avoir choisi un emplacement, une bonne préparation du site est essentielle. Le site doit être de niveau. La serre doit être montée sur un socle. Construisez d'abord la base pour que la serre puisse être montée solidement. Nous recommandons de construire une base de plate-forme en bois en utilisant un périmètre de deux par quatre rempli de terre, de gazon ou de gravier. Les instructions pour la construction d'une plate-forme en bois se trouvent dans ce manuel.

Les autres options de base appropriées comprennent les terrasses en bois et les dalles de béton. Des vis à bois sont incluses pour fixer la serre à une base en bois. La serre est fixée au sol de l'intérieur avec des ancrages au sol. Voir l'étape 11 pour plus de détails. Si vous utilisez une base en béton, procurez-vous les vis de montage appropriées avant de commencer.

Assurez-vous que les coins sont carrés en mesurant les diagonales intérieures des deux côtés et en vous assurant qu'elles sont égales. Utilisez un niveau à bulle pour vous assurer que la base est de niveau.

Contactez vos autorités locales concernant les permis ou restrictions de construction requis.

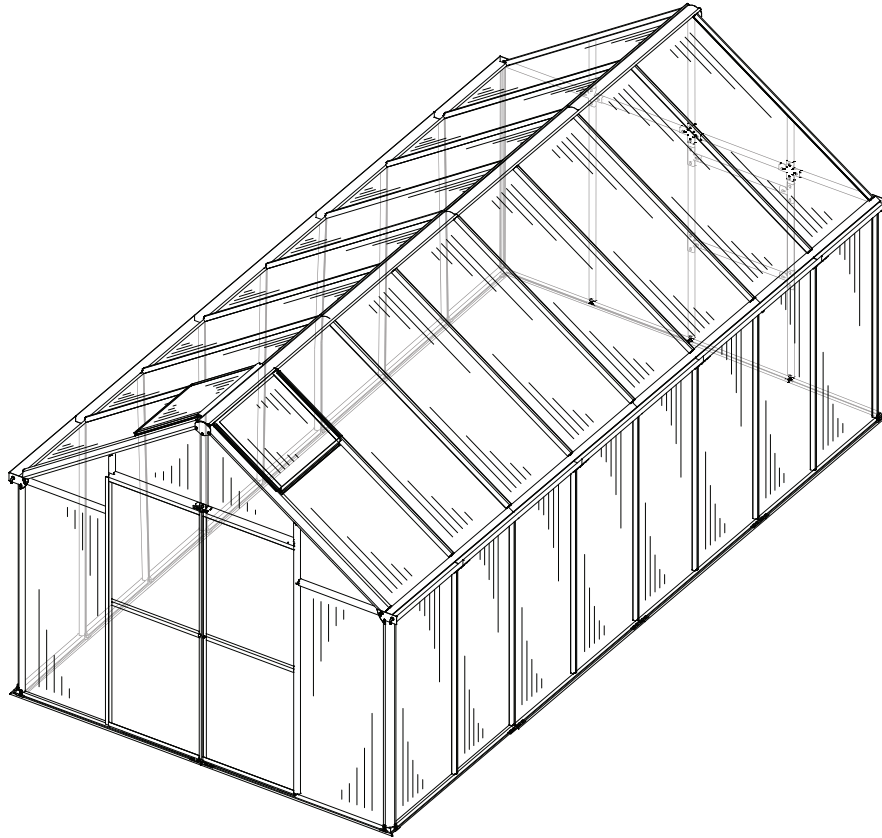

La introducción

Gracias por comprar el invernadero Mont™. La línea Mont se fabrica con orgullo en los EE. UU. utilizando materiales y diseños de calidad profesional. El marco está construido con aluminio extruido de la más alta calidad con pintura con recubrimiento en polvo sin plomo. Los paneles son de policarbonato de pared doble de 8 mm de grado profesional seleccionados por su aislamiento y durabilidad.

La Lista de piezas tiene el número de paso correspondiente referenciado a cada parte para que pueda prepararse fácilmente para cada paso. Recomendamos colocar todas las piezas en un área de preparación. Distribuya las piezas por tamaño y forma. Utilice la Lista de piezas para identificar los números de pieza de los perfiles y paneles. No hemos etiquetado las piezas con pegatinas para evitar quitarlas durante el montaje.

Nuestro invernadero ha sido diseñado para ser montado fácilmente. Aunque una sola persona puede completar todos los pasos menos uno, recomendamos utilizar un ayudante para todo el montaje. Necesitará la ayuda de otra persona para montar el techo. Si nunca antes ha montado un invernadero, conviértalo en un proyecto de fin de semana. Le recomendamos que se tome su tiempo y lea atentamente estas instrucciones para evitar errores.

NOTA: Estas instrucciones incluyen consejos útiles e información importante necesaria para ensamblar y mantener el invernadero de manera segura. Lea estas instrucciones completamente antes de comenzar.

Envíenos fotos de su nuevo invernadero para publicarlas en el sitio web de Riverstone.
Comuníquese con nosotros si tiene preguntas en Servicio al cliente: (877) 373-3078
Correo electrónico: customerservice@rsiww.com Línea de ayuda fuera del horario de atención: (443) 574-4764



LEA ATENTAMENTE TODAS LAS INSTRUCCIONES ANTES DE COMENZAR.
SIGA LOS PASOS EN EL ORDEN PRESENTADO. CONSERVE ESTE MANUAL PARA FUTURAS CONSULTAS.

Varios días antes de comenzar el montaje:

1. Asegúrese de tener todas las piezas necesarias:

Compare el contenido de las cajas con la Lista de piezas. Si falta alguna pieza o dañado, comuníquese con el Servicio de atención al cliente de Riverstone varios días antes de comenzar el ensamblaje para que haya tiempo de obtener las piezas faltantes o de repuesto sin retrasar el proceso de ensamblaje. Durante el horario comercial, llame al (877) 373-3078, correo electrónico: customerservice@rsiww.com o utilice la línea de ayuda fuera del horario de atención: (443) 574-4764.

2. Coloque las piezas en un área de preparación:

La Lista de piezas tiene el número de paso correspondiente referenciado a cada parte para que pueda prepararse fácilmente para cada paso. Recomendamos colocar todas las piezas en un área de preparación. Distribuya las piezas por tamaño y forma. Utilice la Lista de piezas para identificar los números de pieza de los perfiles y paneles. No hemos etiquetado las piezas con pegatinas para evitar quitarlas durante el montaje. Compruebe muy de cerca que tiene el número necesario de piezas para cada paso.

3. Seleccione una ubicación:

Al seleccionar un sitio para su invernadero, una superficie plana es esencial y, si es posible, con un drenaje de agua adecuado y un fácil acceso a la energía y el agua necesarios para jardinería en invernadero. Elija una posición soleada y nivelada lejos de sobresalir árboles y cables eléctricos y protegidos del viento tanto como sea posible. La ubicación debe estar alejada de estructuras que puedan hacer que la nieve se derrame sobre o alrededor del invernadero. Ubique tuberías o cables subterráneos antes de preparar el sitio o anclar el invernadero.

4. Prepare una base:

Después de elegir una ubicación, la preparación adecuada del sitio es esencial. El sitio debe estar nivelado. El invernadero debe montarse sobre una base. Primero construya la base para que el invernadero se pueda montar de forma segura. Recomendamos construir una base de plataforma de madera usando un perímetro de dos por cuatro relleno con tierra, césped o grava. Las instrucciones para construir una plataforma de madera se pueden encontrar en este manual.

Otras opciones de base adecuadas incluyen plataformas de madera y losas de hormigón. Se incluyen tornillos para madera para asegurar el invernadero a una base de madera. El invernadero se fija al suelo desde el interior con anclajes al suelo. Consulte el paso 11 para obtener más detalles. Si esta usando una base de hormigón, obtenga los tornillos de montaje adecuados antes de comenzar.

Asegúrese de que las esquinas estén cuadradas midiendo las diagonales interiores de ambos lados y asegurándose de que sean iguales. Use un nivel de burbuja para asegurarse de que la base esté nivelada.

Comuníquese con las autoridades locales con respecto a los permisos o restricciones de construcción necesarios.

Safety Advice

- The greenhouse must be positioned and fixed on a flat level surface.
- Dispose of all plastic bags safely. Keep them out of the reach of small children.
- Keep children and pets away from the assembly area until the work is completed.
- Always wear work shoes, gloves and safety goggles when working.
- Some of the parts have sharp edges and burs. Use extreme caution when handling.
- Do not lean against or push the greenhouse during assembly.
- Take special care not to touch overhead power lines with the aluminum profiles.
- Do not attempt to assemble the greenhouse in windy or wet conditions.
- Do not position your greenhouse in an area exposed to excessive wind.
- If using power tools or a step ladder, always follow the manufacturer's safety instructions.
- Hot items such as recently used grills, blow torches etc., must not be stored in the greenhouse.
- Store the polycarbonate panels in a cool dark place such as a garage until you are ready to use them.
- Make sure the greenhouse complies with local building codes.
- Heat the greenhouse during winter months to avoid accumulation of snow or ice on the roof.

Table of Contents

Warranty	4
Introduction	9
Safety Advice	15
General Order of Assembly.....	15
Construct Wood Platform.....	18
List of Parts.....	21
Using T-bolts.....	27
Icon Key.....	27
Pre-Assembly	29
Assemble Base.....	37
Assemble Right Wall	39
Assemble Back Wall	46
Assemble Left Wall	54
Assemble Front Wall and Gable	60
Assemble Back Gable	69
Install Roof Ridge.....	72
Assemble Roof.....	74
Install Roof Vents	84
Install Doors	89
Secure to Platform	92
Install Fan and Solar Panel	93

General Order of Assembly

Pre-Assembly

- Step 1: Assemble Base
- Step 2: Assemble Right Wall
- Step 3: Assemble Back Wall
- Step 4: Assemble Left Wall
- Step 5: Assemble Front Wall and Gable
- Step 6: Assemble Back Gable
- Step 7: Install Roof Ridge
- Step 8: Assemble Roof
- Step 9: Install Roof Vents
- Step 10: Install Doors
- Step 11: Secure to Platform
- Step 12: Install Fan and Solar Panel

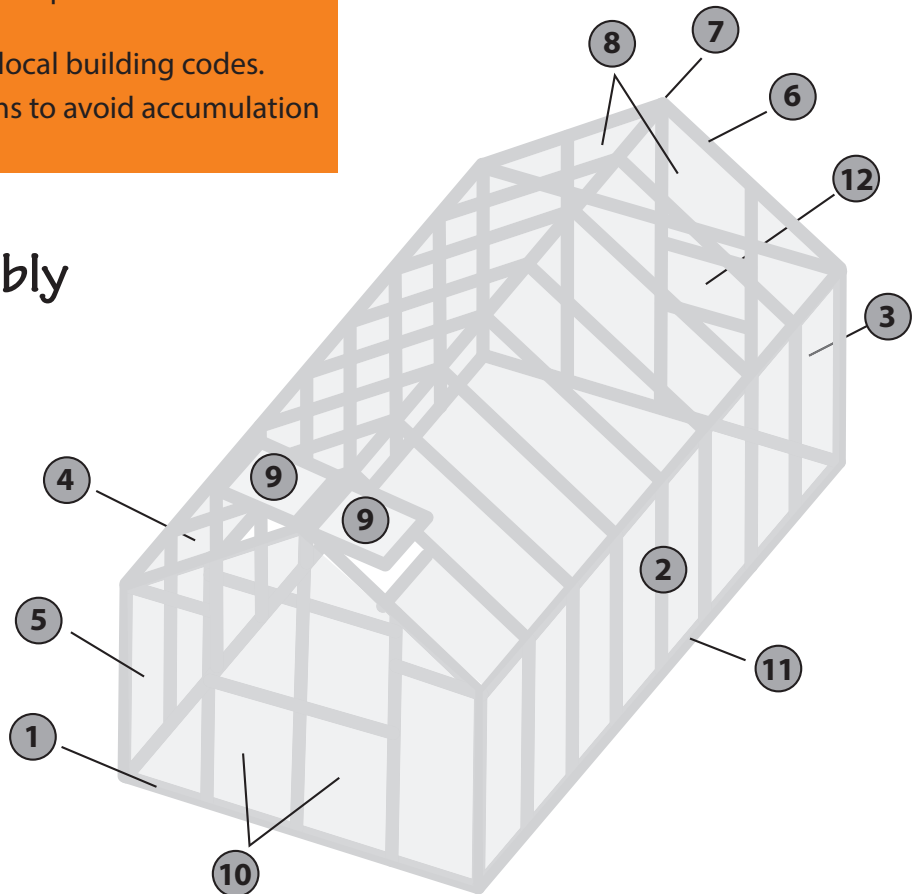

Tools Needed

- Safety Goggles
- Step Ladder
- Work Gloves
- Spirit Level
- Tape Measure
- 23 1/8 inch spacer (included)
- 7/16" wrench (included)
- Phillips Screwdriver (included)
- Flat Screwdriver (included)
- 5 foot bungee cord (included)
- clear silicone caulk tube

- La serre doit être positionné et fixé sur un plat surface plane.
- Jetez tous les sacs en plastique en toute sécurité. Gardez-les hors de la portée des petits enfants.
- Gardez les enfants et les animaux loin de la zone d'assemblage jusqu'à ce que le travail est terminé.
- Toujours porter des chaussures de travail, des gants et des lunettes de sécurité lors du travail.
- Certaines pièces ont des arêtes vives et des fraises. Utilisez extrême la prudence lors de la manipulation.
- Ne vous penchez pas contre ou pousser la serre pendant l'assemblage.
- Faites attention à ne pas toucher les lignes électriques aériennes avec le les profilés en aluminium.
- Ne tentez pas de monter la serre venteux ou humide conditions.
- Ne placez pas votre effet de serre dans une zone exposée à vent excessif.
- Si vous utilisez des outils électriques ou un escabeau, toujours suivre la sécurité les instructions du fabricant.
- Articles chauds tels que des grils, les chalumeaux, etc. ne doivent pas être stockées dans la serre.
- Rangez les panneaux de polycarbonate dans un endroit sombre et frais tels qu'un garage jusqu'à ce que vous êtes prêt à les utiliser.
- Assurez-vous que la serre est conforme aux codes de construction locaux.
- Chauffer la serre pendant les mois d'hiver pour éviter l'accumulation de neige ou de glace sur le toit.

Garantie	5
Introduction	11
Conseils de sécurité	16
Ordonnance générale de l'Assemblée.....	16
Construire la plate-forme en bois.....	19
Liste des parties	21
Utilisation de T- boulons	27
Clé Icon.....	27
Pré-assemblage.....	29
Assembler la Base.....	37
Assembler droit mur	39
Assembler Retour mur.....	46
Assembler Gauche mur.....	54
Assembler mur avant et Gable	60
Assembler Retour Gable	69
Installer Roof Ridge	72
Assembler le toit	74
Installer les événements de toit	84
installer des portes	89
Sécurisé à la plate-forme	92
Installation du ventilateur et panneau solaire ...	93

Ordonnance Générale de l'Assemblée

Pré-assemblage

- Étape 1: Assemblez la base
- Étape 2: Assembler le mur droit
- Étape 3: Assembler le mur arrière
- Étape 4: Assembler le mur de gauche
- Étape 5: Assembler le mur avant et le pignon
- Étape 6: Assembler le pignon arrière
- Étape 7: Installer Roof Ridge
- Étape 8: Assembler le toit
- Étape 9: Installer les événements de toit
- Étape 10: Installation des portes
- Étape 11: Secure to Platform
- Étape 12: Installation du ventilateur et panneau solaire

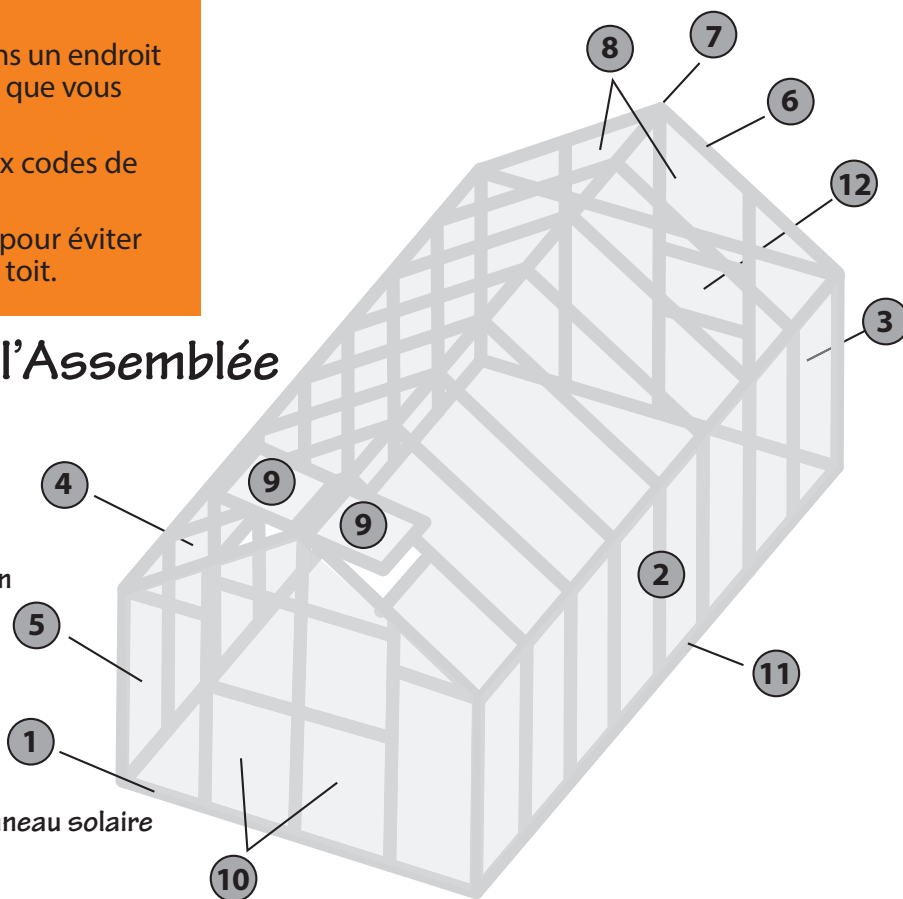

Outils nécessaires

- | | | | |
|--------------------|------------------------|---------------------------------------|---|
| • Escabeau | • Lunettes de sécurité | • Mètre à ruban | • Tournevis plat (inclus) |
| • Gants de travail | • Niveau de Spirit | • 23 1/8 pouces d'espacement (inclus) | • cordon élastique de 5 pieds (inclus) |
| | | • 7/16" clé (inclus) | • tube de calfeutrage en silicone transparent |
| | | • Tournevis Phillips (inclus) | |

Consejos de seguridad

- El invernadero debe estar colocado y fijado sobre una superficie plana superficie nivelada.
- Deseche todas las bolsas de plástico de forma segura. Mantenerlos fuera de la alcance de los niños.
- Mantenga a los niños y mascotas lejos de la zona de montaje hasta el trabajo se ha completado.
- Siempre use zapatos de trabajo, guantes y gafas de seguridad cuando trabajan.
- Algunas de las piezas tienen bordes afilados y las fresas. Tenga mucho precaución al manejar.
- No se apoye o empujar el invernadero durante el montaje.
- Tenga especial cuidado de no tocar las líneas eléctricas aéreas con el perfiles de aluminio.
- No intente montar el invernadero en el viento o en húmedo condiciones.
- No coloque su invernadero en un área expuesta a viento excesivo.
- Si está utilizando herramientas eléctricas o una escalera de mano, siga siempre el instrucciones de seguridad del fabricante.
- artículos calientes tales como parrillas recién usadas, sopletes, etc. no debe ser almacenada en el invernadero.
- Guarde los paneles de policarbonato en un lugar fresco y oscuro, como una garaje hasta que esté listo para usarlos.
- Asegúrese de que el efecto invernadero cumpla con los códigos de construcción locales.
- Calentar el invernadero durante los meses de invierno para evitar la acumulación de nieve o hielo en el techo.

Tabla de contenido

Garantía	6
Introducción.....	13
Consejo de seguridad.....	17
Orden General de la Asamblea.....	17
Construir plataforma de madera	20
Lista de piezas	21
Usando pernos en T.....	27
Llave de icono.....	27
Preasamblea.....	29
Montar la base.....	37
Montar la pared derecha	39
Montar la pared trasera.....	46
Montar la pared izquierda.....	54
Montar la pared frontal y Gable	60
Montar el Gable trasero	69
Instalar Roof Ridge.....	72
Montar el techo.....	74
Instale los respiraderos del techo.....	84
Instalar puertas	89
Asegurar a la plataforma	92
Instalar el ventilador y el panel solar...	93

Orden General de la Asamblea

Preasamblea

- Paso 1: ensamblar la base
- Paso 2: montar la pared derecha
- Paso 3: ensamblar la pared posterior
- Paso 4: montar la pared izquierda
- Paso 5: montar la pared frontal y el aguilón
- Paso 6: montar gablete trasero
- Paso 7: instala Roof Ridge
- Paso 8: ensamblar el techo
- Paso 9: Instale los respiraderos del techo
- Paso 10: instala las puertas
- Paso 11: Asegurar a la plataforma
- Paso 12: Instalar el panel del ventilador y Solar

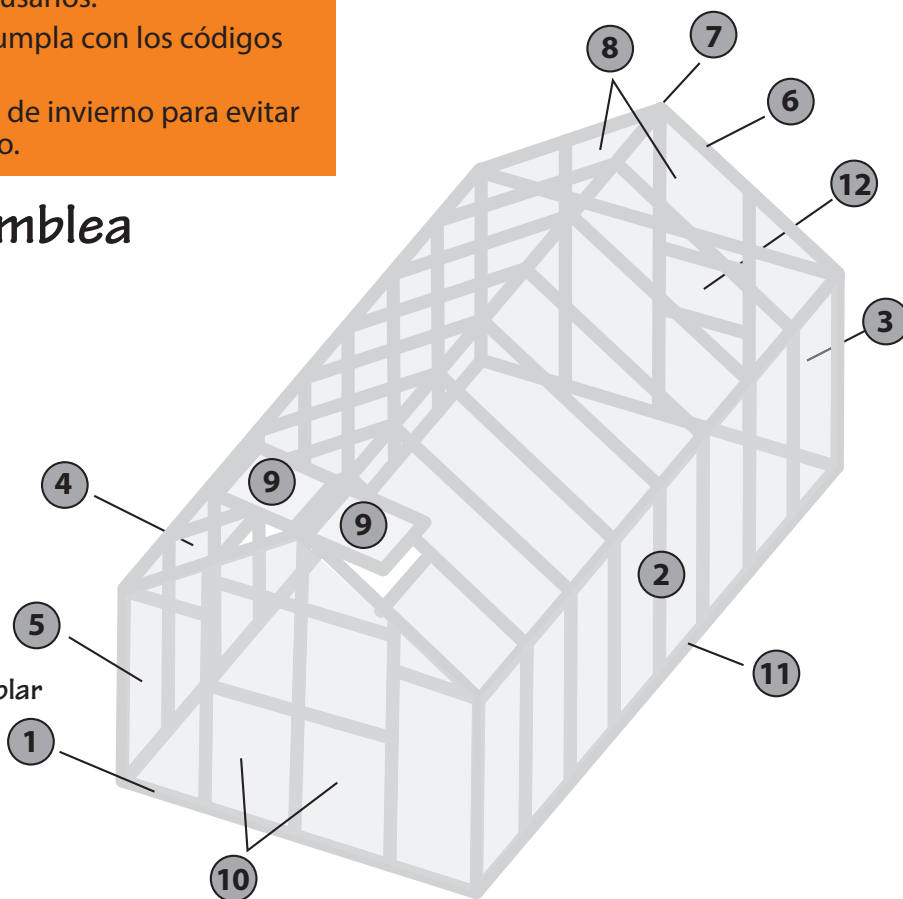

Herramientas necesarias

- Escalera plegable
- Gafas protectoras
- 23 1/8 pulgadas espaciador (incluido)
- Cinta métrica
- Destornillador Phillips (incluido)
- Destornillador plano (incluido)
- cuerda elástica de 5 pies (incluido)
- Guantes de trabajo
- Nivel espiritual
- llave de 7/16" (incluida)
- tubo de masilla de silicona clara

Constructing a Wood Platform



IMPORTANT: It is very important to begin with a level surface. Check your foundation to ensure it is level at every point. If you are not building on a wood deck, we recommend constructing a wood platform so you can properly secure the greenhouse. You must assure your foundation is square and level before beginning assembly.

After choosing a location, proper preparation of the site is essential. The site must be level. Create a wood platform using a perimeter of pressure treated two by fours filled with either soil, sod or gravel.

NOTE: When constructing the greenhouse on a wood deck, make certain the surface is level. Creating an additional wood platform is not necessary.

Buy pressure treated 2x4 lumber. You will use two layers with the corner positions staggered for maximum strength. The finished dimensions will be 101" by 198¹/₄"

Materials:

Four 10' pressure treated 2x4 lumber cut to 97¹/₂"

Four 10' pressure treated 2x4 lumber uncut at 120"

Four 8' pressure treated 2x4 lumber cut to 74³/₄"

Eighty #8 3" wood screws

Tools:

Spirit Level

Corner Square

Phillips Screwdriver

Power Drill (recommended)

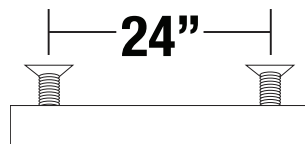
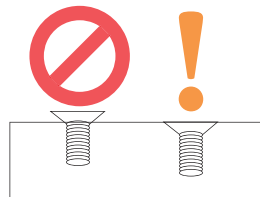
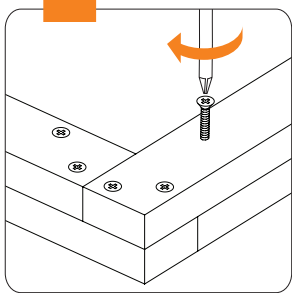
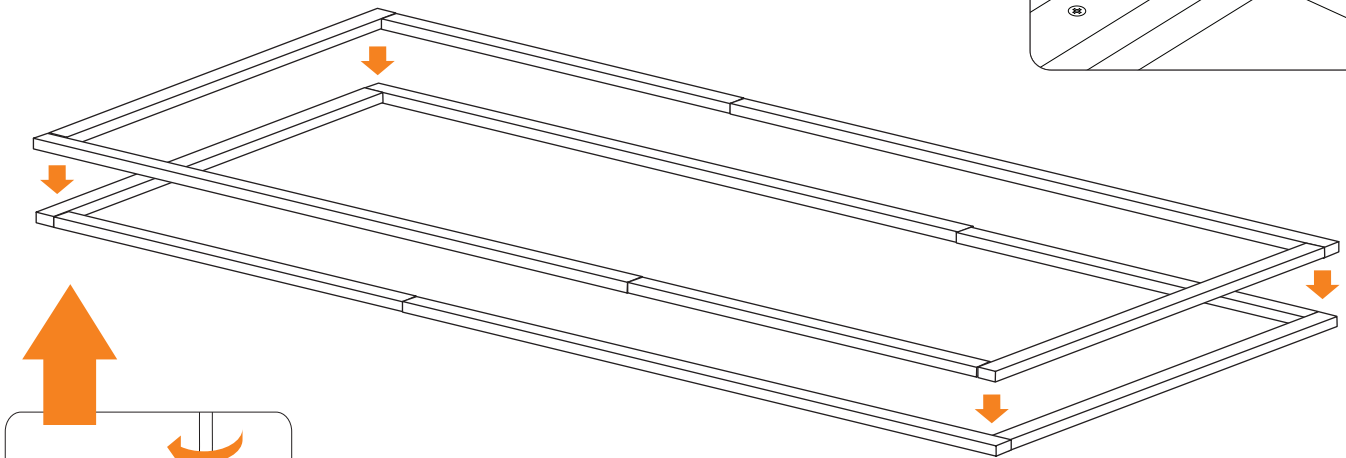
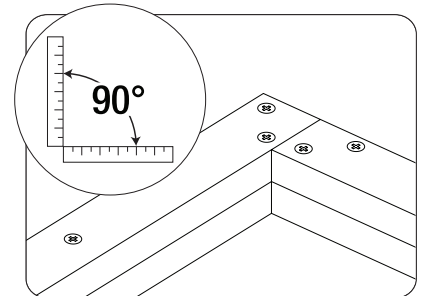
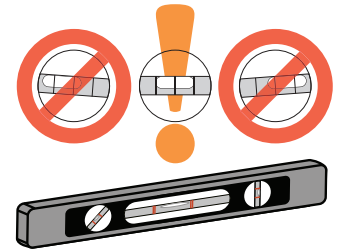

NOTE: The illustrations throughout the manual are shown without a foundation.



Scan This QR Code!
To be taken to helpful Pro-tips, techniques, and assembly videos!
Reference #01

La construction d'une plate-forme en bois



IMPORTANT : Il est très important de commencer par une surface plane . Vérifiez votre fondation pour assurer qu'il est de niveau à chaque point. Si vous n'êtes pas la construction sur une terrasse en bois , nous vous recommandons de construire une plate-forme de bois afin que vous puissiez correctement sécuriser la serre . Vous devez assurer votre fondation est carré et de niveau avant de commencer l'assemblage .

Après avoir choisi un emplacement , une bonne préparation du site est essentiel . Le site doit être de niveau . Créer un bois la plate-forme à l'aide d'un périmètre de traité sous pression des deux par quatre remplis soit avec le sol , le gazon ou le gravier .

NOTE : Lors de la construction de la serre sur une terrasse en bois , assurez-vous le surface est plane . La création d'une plate-forme en bois supplémentaire est inutile.

Acheter traité sous pression 2x4 . Vous allez utiliser deux couches avec les positions d'angle en quinconce pour un maximum force. Les dimensions finales seront 101" par 198¹/₄"

Matériaux:

Quatre 10' traité sous pression
2x4 coupé à 97¹/₂"

Quatre 14' bois traité sous pression
2x4 uncut à 120"

Quatre 8' traité sous pression
2x4 coupé à 74³/₄"

Quatre-vingts # 8 3 vis à bois

Outils:

Niveau à bulle
coin Carré

Phillips Screwdriver

Perceuse électrique (recommandé)

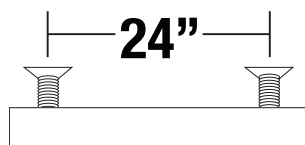
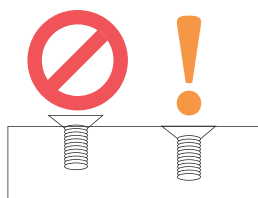
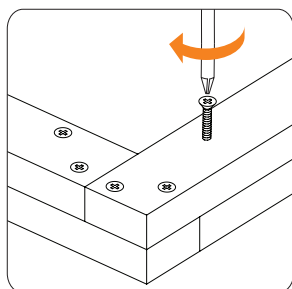
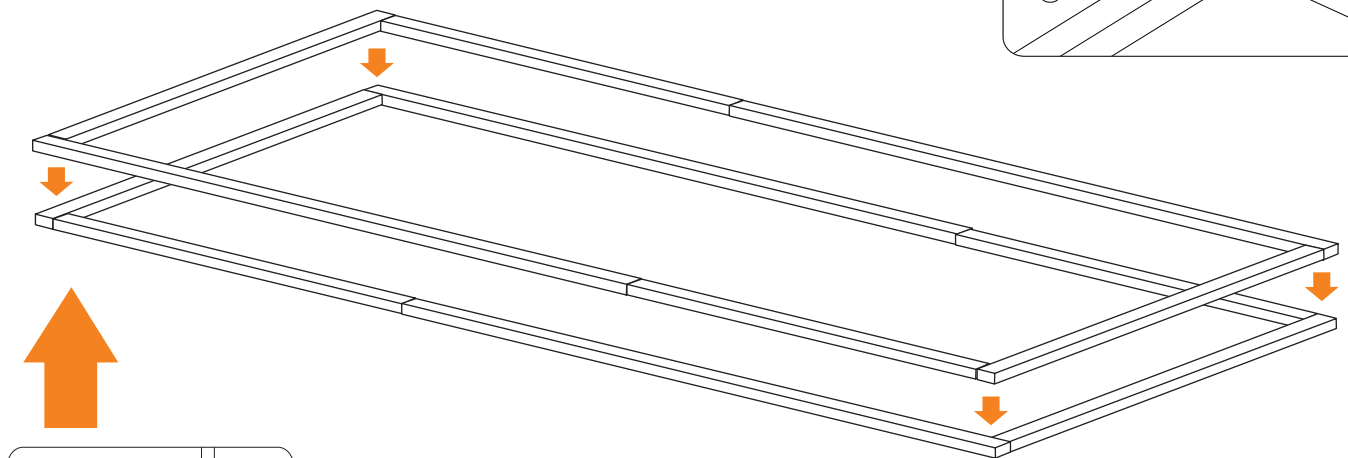
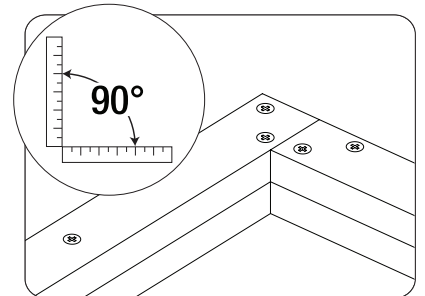
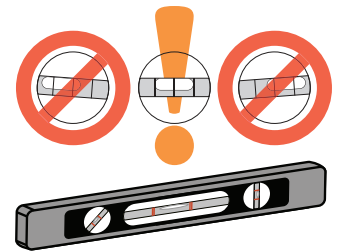

NOTE : Les illustrations tout au long du manuel sont présentés sans fondement .



Scan This QR Code!
To be taken to helpful
Pro-tips, techniques,
and assembly videos!
Reference #01

La construcción de una plataforma de madera



IMPORTANTE : Es muy importante comenzar con una superficie nivelada. Compruebe su fundación para asegurar que esté en cada nivel punto. Si no está construyendo en una cubierta de madera, se recomienda la construcción de una plataforma de madera para que pueda adecuadamente asegurar el efecto invernadero. Usted debe asegurarse de que su fundación es cuadrada y nivelada antes de comenzar el montaje.

Después de elegir un lugar, una preparación adecuada del sitio es esencial. El sitio debe estar al mismo nivel. Crear una madera plataforma usando un perímetro de presión tratada de dos en cuatro patas llenas de cualquiera de suelo, césped o grava.

NOTA : En caso de construcción del invernadero en una cubierta de madera, asegúrese de que el superficie está nivelada . Creación de una plataforma de madera adicional no es necesario.

Comprar tratada a presión madera de 2x4. Que va a utilizar dos capas con las posiciones de esquina escalonadas para una máxima fuerza. Las dimensiones finales serán 101" por 198¹/₄"

Materiales:

Cuatro 10' tratada a presión de 2x4 madera cortada a 97¹/₂"

Cuatro 14' madera tratada a presión de 2x4 sin cortes en el 120"

Cuatro 8' tratada a presión de 2x4 madera cortada a 74³/₄"

Ochenta # 8 3 tornillos para madera

Herramientas:

Nivel espiritual

Plaza de esquina

Phillips screwdriver

Taladro de potencia (recomendado)

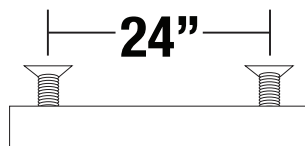
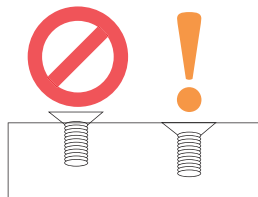
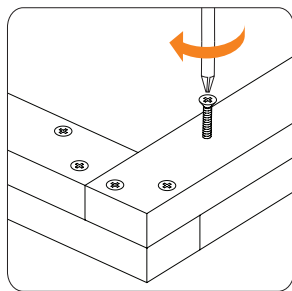
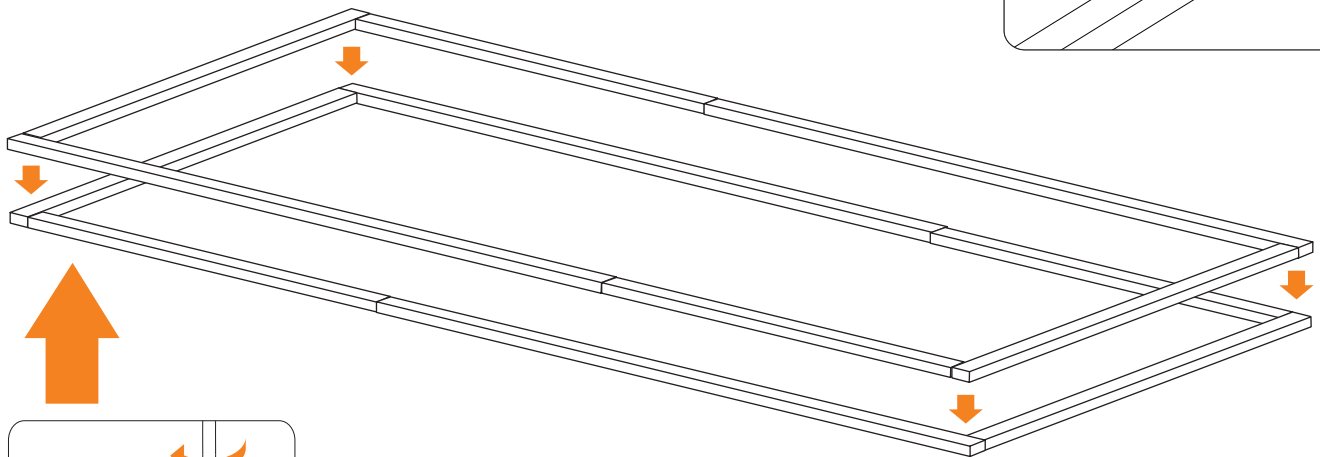
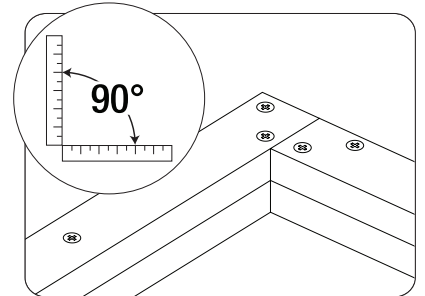
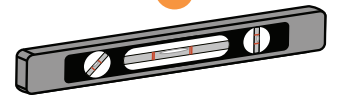
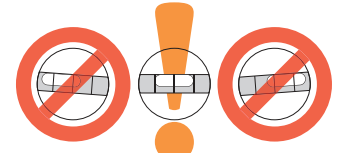

NOTA : Las ilustraciones a lo largo del manual se muestran sin una base .



Scan This QR Code!
To be taken to helpful
Pro-tips, techniques,
and assembly videos!
Reference #01

List of Parts



WARNING: Profiles with cut edges and/or drilled holes are sharp. Use extreme caution when handling.



The greenhouse is shipped in multiple cartons. These cartons are heavy. Use care when lifting them. Some parts have sharp edges. Use extreme caution when handling. Wear proper safety gear including work shoes, gloves and safety goggles.

Keep children and pets away until assembly is complete. Finish assembling the roof in one session. Do not leave the roof unattended until it is completely assembled. Place all like parts together in a staging area. Prepare for each step according to instructions in this manual.

If any parts are missing or damaged, before beginning assembly contact Riverstone Customer Service at (877) 373-3078, email: customerservice@rsiww.com or After Hours Helpline: (443) 574-4764

List of Parts



WARNING: Profiles with cut edges and/or drilled holes are sharp. Use extreme caution when handling.



La serre est livrée dans plusieurs cartons. Ces cartons sont lourds. Faites attention lorsque vous les soulevez. Certaines parties ont des arêtes vives. Soyez extrêmement prudent lors de la manipulation. Porter un équipement de sécurité approprié, y compris des chaussures de travail, des gants et des lunettes de sécurité. Gardez les enfants et les animaux loin jusqu'à ce que le montage est terminé. Terminer l'assemblage du toit en une seule session. Ne pas laisser le toit sans surveillance jusqu'à ce qu'il soit complètement assemblé. Placez toutes les pièces comme ensemble dans une zone de transit. Préparez-vous à chaque étape selon les instructions de ce manuel.

Si des pièces sont manquantes ou endommagées, avant de commencer le contact d'assemblage de service à la clientèle Riverstone au (877) 373-3078, courriel: customerservice@rsiww.com ou After Hours Helpline : (443) 574-4764

Lista de piezas



ADVERTENCIA: Los perfiles con bordes cortados y/o agujeros perforados son agudos. Tenga mucho cuidado al manejar.



El invernadero se envía en múltiples cajas de cartón. Estas cajas son pesadas. Tenga cuidado al levantarlos. Algunas partes tienen bordes afilados. Tenga mucho cuidado al manejar. Usar equipo de seguridad adecuado, incluyendo zapatos de trabajo, guantes y gafas de seguridad. Mantenga a los niños y mascotas lejos hasta que el montaje se ha completado. Terminar el montaje del techo en una sola sesión. No deje desatendido el techo hasta que esté completamente ensamblada. Coloque todas las piezas como juntas en un área de ensayo. Preparar para cada paso de acuerdo con las instrucciones contenidas en este manual.

Si falta alguna pieza o está dañada, antes de comenzar el montaje de contactos de Servicio al Cliente Riverstone al (877) 373-3078, correo electrónico : customerservice@rsiww.com o después de horas línea de ayuda : (443) 574-4764

List of Parts (continued)



WARNING: Use extreme caution when handling panels with cut edges. The corners are sharp.

Profile	PT#	QTY	Steps
	F-1	29	2, 3, 4, 8
	F-2	1	6
	F-4	1	5
	F-5	1	5
	F-6	4	5, 6
	F-7	8	2, 3, 4, 5, 6
	F-8	4	5, 6



Profile	PT#	QTY	Steps
	F-10	4	3
	G-1	4	2, 4
	G-2	6	2, 4
	P-1A	4	1
	P-1B	4	1
	P-2A	2	1
	P-2B	2	1
	R-1	2	1
	R-1E	2	7

List of Parts (continued)

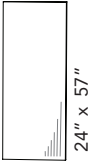
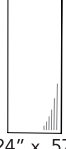
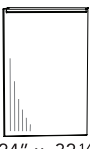
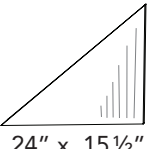
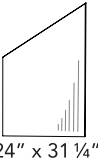
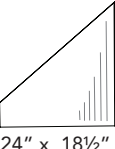
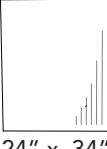

WARNING: Use extreme caution when handling panels with cut edges. The corners are sharp.

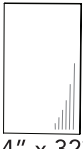
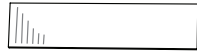

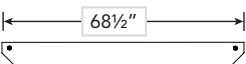
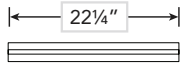
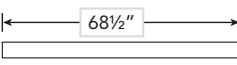

Profile	PT#	QTY	Steps
 24" x 57"	W-1	21	2, 3, 4
 24" x 57"	W-8	14	8
 24" x 32 1/4"	W-10	2	8
 24" x 15 1/2"	W-3	4	4, 5
 24" x 31 1/4"	W-4	2	6
 24" x 18 1/2"	W-5	2	4
 24" x 34"	W-6	4	10

Profile	PT#	QTY	Steps	
 24" x 32 1/2"	W-7	1	3	
 4 1/2" x 24"	W-9	1	3	
Assembled Vents		PT#	QTY	Steps
	V-4	2	9	
Door Profiles		PT#	QTY	Steps
 24"	E-1	4	10	
 68 1/2"	E-2	4	10	
 22 1/4"	E-3	2	10	
 68 1/2"	E-4	1	10	

List of Parts (continued)

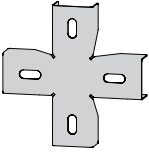

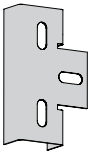
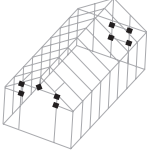
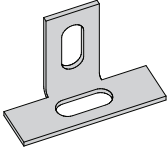
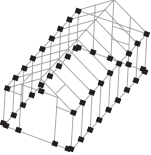
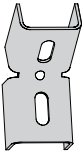
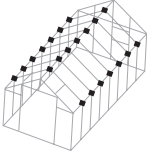
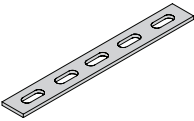
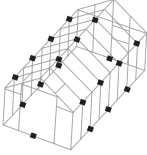
WARNING: Use extreme caution when handling panels with cut edges. The corners are sharp.

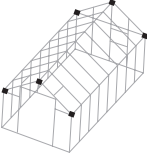
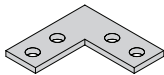
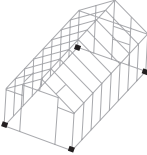

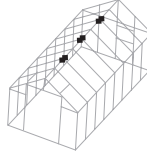
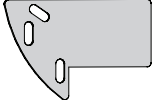
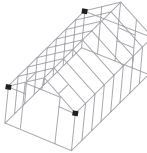
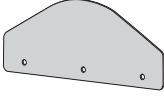
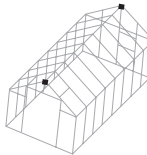
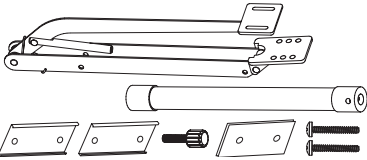
Connectors	PT#	QTY	Steps
 	B-1	6	6
 	B-2	9	3, 5
 	B-3	62	2, 3, 4, 5, 10
 	B-4	21	8
 	B-5	19	1, 2, 4, 7
 	B-7	6	5, 6, 7
 	B-8	4	1







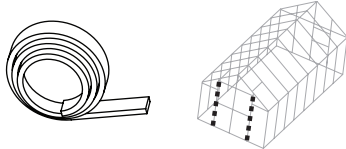
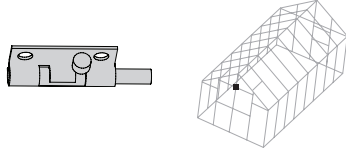
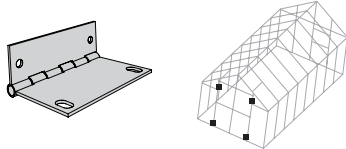
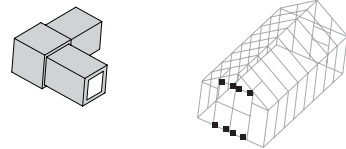
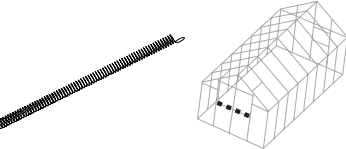
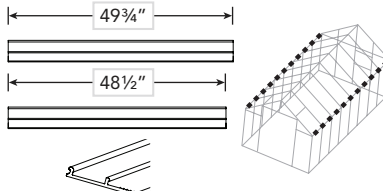





Connectors	PT#	QTY	Steps
 	B-10	6	7
 	C-1	4	5,6
 	C-2	2	7
Vent Opener	PT#	QTY	Steps
	V-3	2	9

List of Parts (continued)

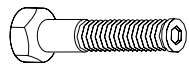

WARNING: Use extreme caution when handling panels with cut edges. The corners are sharp.

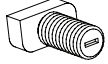
Connectors	PT#	QTY	Steps
	D-4	20'	10
	D-7	1	10
	D-8	4	5
	D-9	8	10
	D-10	2	10
Trim Plates	PT#	QTY	Steps
	G-4	4	8
	G-4E	4	8

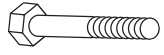
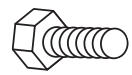
Hardware	PT#	QTY	Steps
	S-1	8	9
	S-2C	421	1-8,10-12
	S-2A	2	5
	S-2B	2	5
	S-2D	2	5
	S-4	80	11
	S-5A	3	7
	S-5B	3	8,12
	S-5D	3	8,12
	S-6	4	9
	S-7	421	1-8, 10, 11
	S-8A	8	5
	S-9	38	10
	S-11	4	12
	S-12	8	12

List of Parts (continued)



WARNING: Use extreme caution when handling panels with cut edges. The corners are sharp.

Brace	PT#	QTY	Steps
	B-9	3	8
	B-11	14	8
	B-12	2	8
Gutter Drain	PT#	QTY	Steps
	G-3	4	8
Ground Anchors	PT#	QTY	Steps
	A-1	8	11
	A-2	8	11
Included Tools	PT#	QTY	Steps
 Phillips/Flat Combination Screwdriver	T-10	1	1-11
 7/16" Wrench	T-2	1	1-10
 23 1/8" Spacer	T-3	1	2, 3, 4

Fan Parts	PT#	QTY	Steps
	H-1	2	12
	H-2	2	12
	H-3	2	12
	H-4	2	12
	H-5	4	12
	H-6	1	12
	H-7	1	12
	H-8	1	12
	H-9	1	12
	H-10	10'	12
	H-11	8'	12

Using T-Bolts Utilisant T-Bolts Utilizando T-Bolts

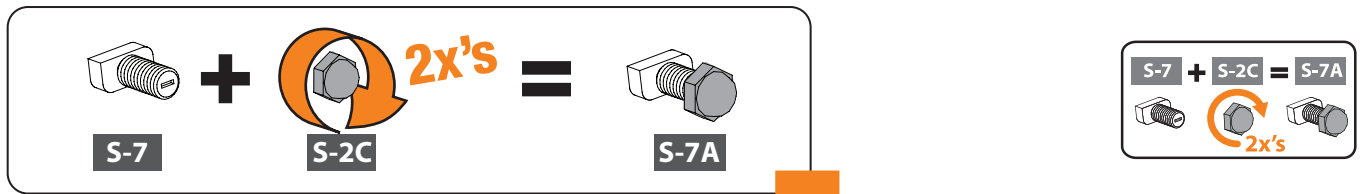

Visit us at
WWW.RSIWW.com/AssemblyQuestions
 for key assembly images and helpful tips.

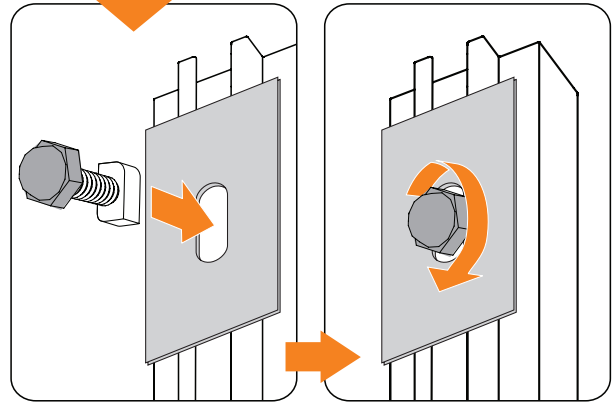

Icon Key Key Icon Clave Icono

x4 Repeat specified number of times.
 Répétition nombre de fois spécifié.
 Repita el número especificado de veces.

(1.3A-1.3E) X 8

Repeat specified steps, specified number of times.

Répétez les étapes indiquées, le nombre de fois spécifié.

Repetir los pasos especificados, el número de veces especificado.



View from inside.
 Vue de l'intérieur.
 Vista desde el interior.



View from outside.
 Vue depuis l'extérieur.
 Ver desde fuera.

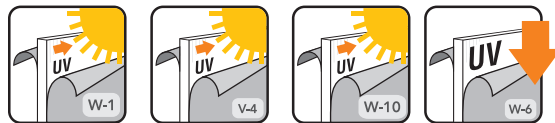

Remove plastic film from both sides of panel.
 Place side marked "UV Resistant" facing outside.

Retirez le film plastique des deux côtés de panneau. Lieu côté marqué "UV résistant" face à l'extérieur.

Retire la película de plástico de ambos lados del panel. Coloque el lado marcado "Resistente a los rayos UV" mirando hacia afuera.

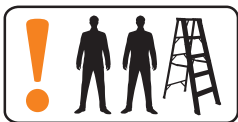

Requires two people and ladder.
 Nécessite deux personnes et échelle.
 Requiere dos personas y escalera.

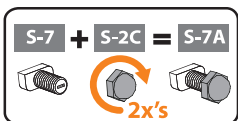

Assemble and insert t-bolt assembly.
 Assembler et insérez l'assemblage t-boulon.
 Montar e inserte el montaje t-perno.



View from below.
 Vue de dessous.
 Ver desde abajo.



View from above.
 Vue d'en haut.
 Vista desde arriba.

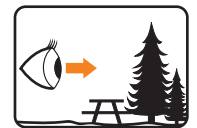

View from side.
 Voir d'un côté.
 Vista desde el lado.



Insert polycarbonate into channel.
 Insérez polycarbonate dans le canal.
 Inserte policarbonato en el canal.



Place channel securely over polycarbonate.
 Placez le canal en toute sécurité sur polycarbonate.
 Coloque canal de forma segura a través de policarbonato.

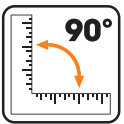

Make sure angle is square.
 Assurez-vous que l'angle est carré.
 Asegúrese de que el ángulo es cuadrada.



Make certain the pieces are in the correct positions before securing. Once set they cannot be un-done!!
 Assurez-vous que les pièces sont dans la bonne position avant de fixer. Une fois mis ils ne peuvent pas être non - fait !!
 Asegúrese de que las piezas están en la posición correcta antes de asegurar. Una vez que establecen que no pueden ser des-hecho!!

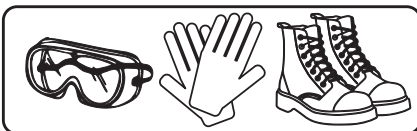

Wear proper safety gear including work shoes, gloves and goggles.
 Porter un équipement de sécurité approprié, y compris des chaussures de travail, des gants et des lunettes.
 Usar equipo de seguridad adecuado, incluyendo zapatos de trabajo, guantes y gafas.

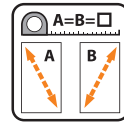

Piece is square if measurements from opposite corners are equal.
 Piece est carré si des mesures à partir des coins opposés sont égaux.
 Pieza es cuadrada si las mediciones de ángulos opuestos son iguales.



Apply aluminum tape.
 Appliquer du ruban d'aluminium.
 Aplicar cinta de aluminio.



Exercise caution: sharp edges!
 Soyez prudent : arêtes vives!
 Tenga cuidado: bordes afilados!



Start here.
 Commencer ici.
 Empieza aqui.

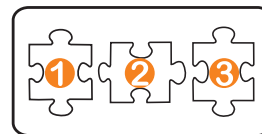

Carefully follow the order of assembly to ensure an easy installation.
 Suivez attentivement l'ordre de montage pour assurer une installation facile.
 Siga cuidadosamente el orden de montaje para asegurar una fácil instalación .

Pre-Assembly Gutters

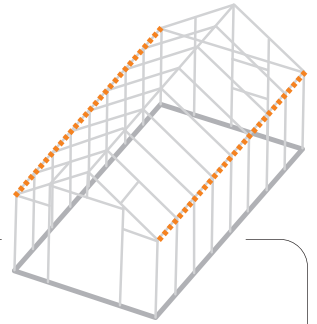
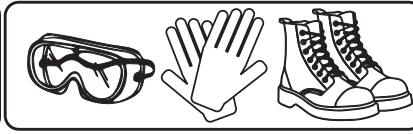
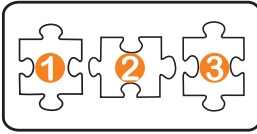

2.4A

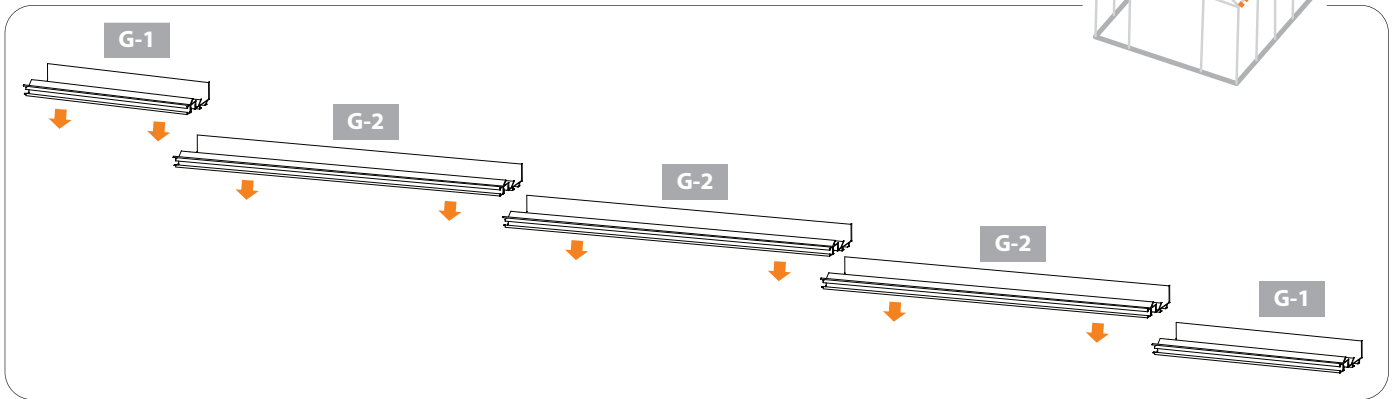

2.4B

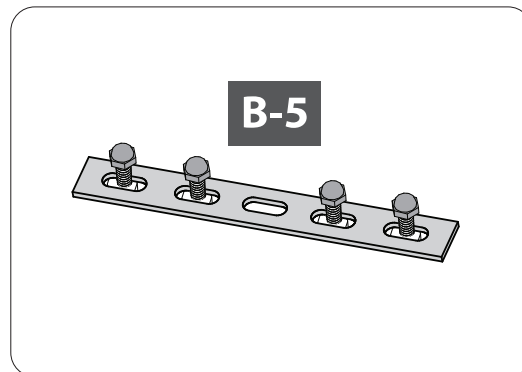
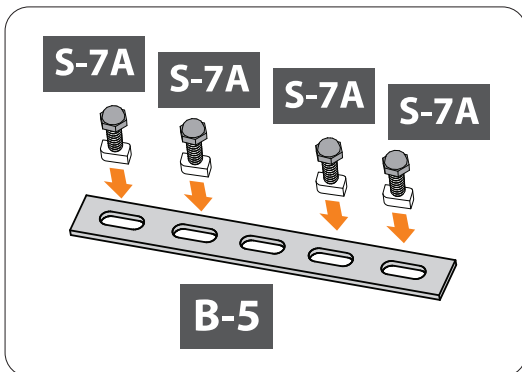

x4

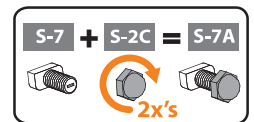

Connector		QTY	Connector		QTY	Profile		QTY
	S-7	16		B-5	4		G-1	2
				S-2C	16		G-2	3

2.5A

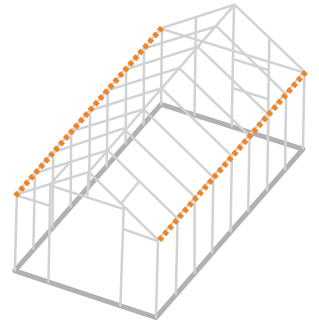
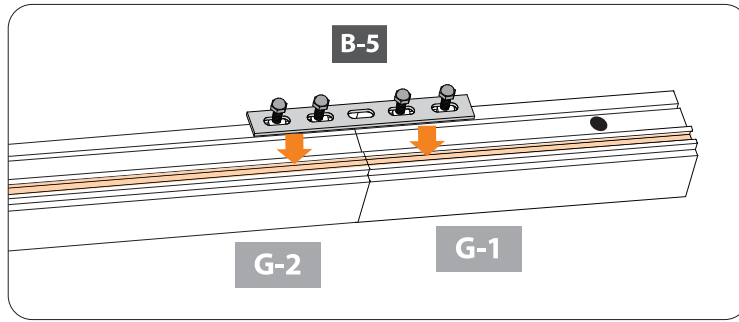

2.5B

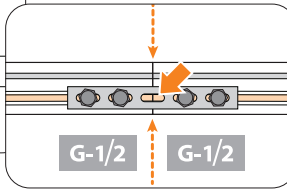
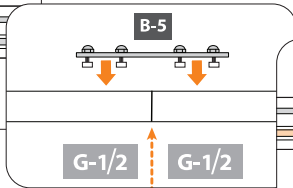
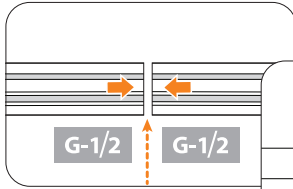

2.5C

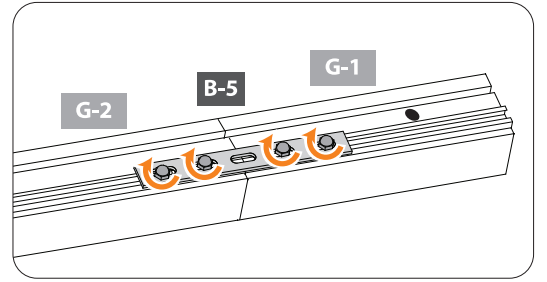

2.5D

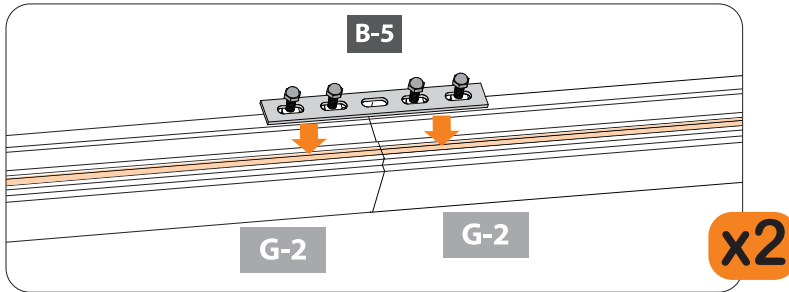

2.5E

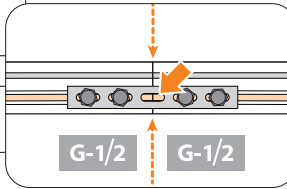
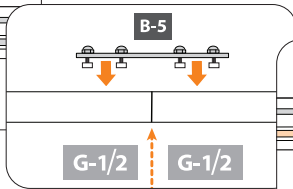
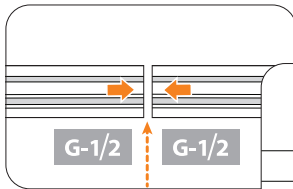

2.5F

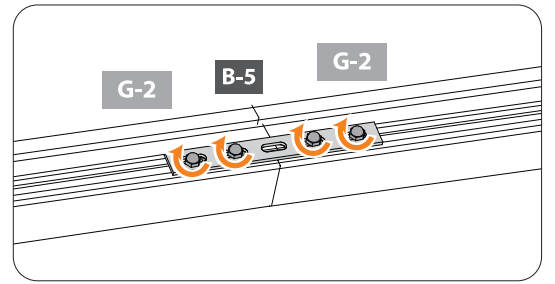

2.5G

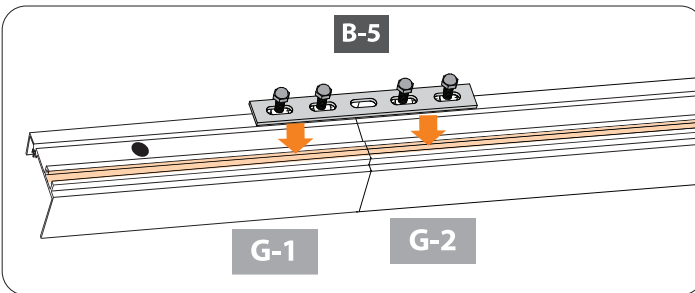

2.5H

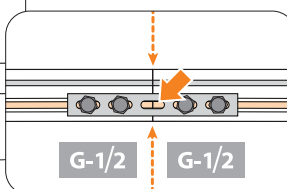
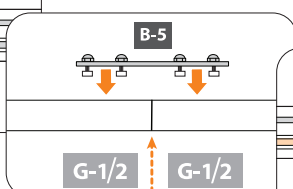
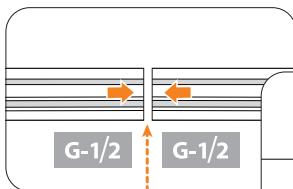

2.5I

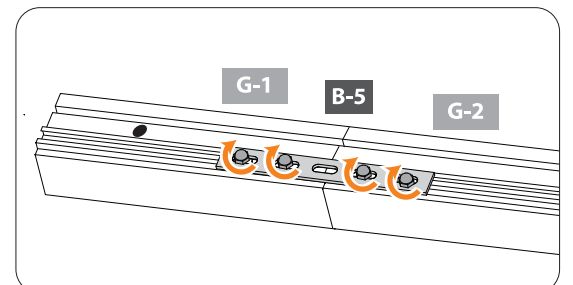

2.5J (2.4A - 2.5I) x 2

Pre-Assembly Roof Ridge

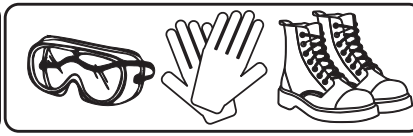
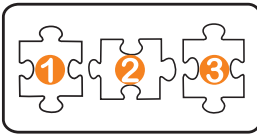

7.1A

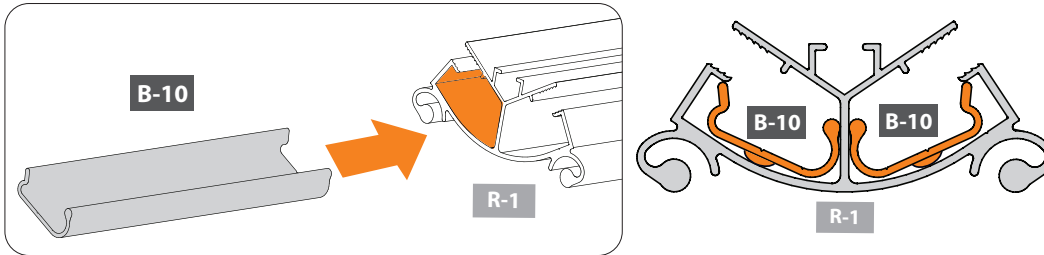
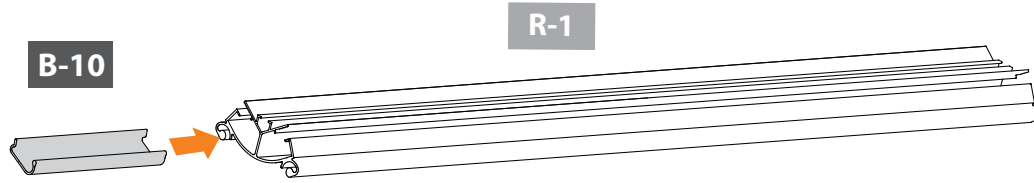

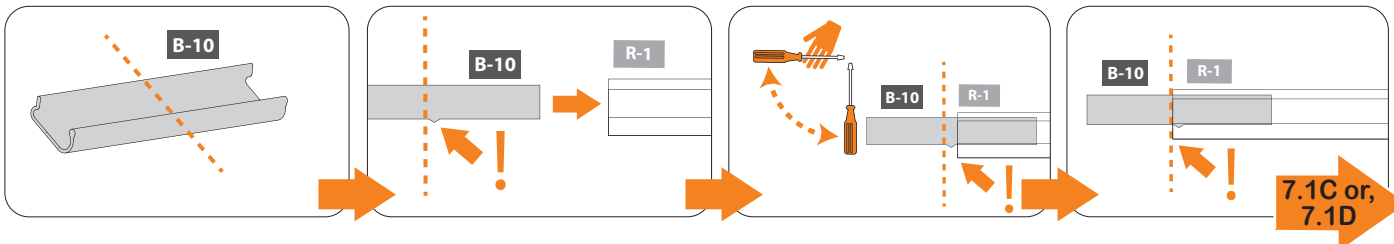

Scan This QR Code!
To be taken to helpful Pro-tips, techniques, and assembly videos!
Reference #03

7.1B

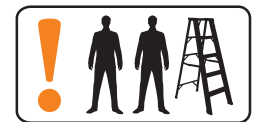
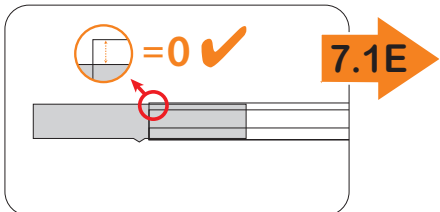

7.1C



7.1D

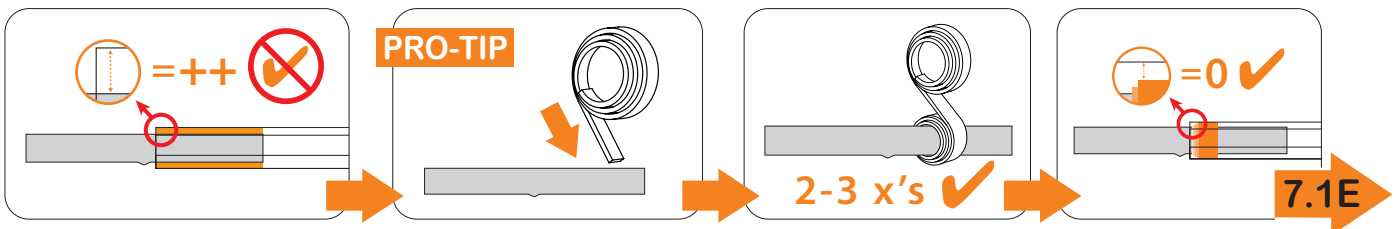

7.1E

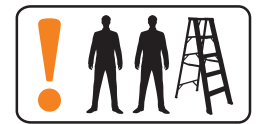
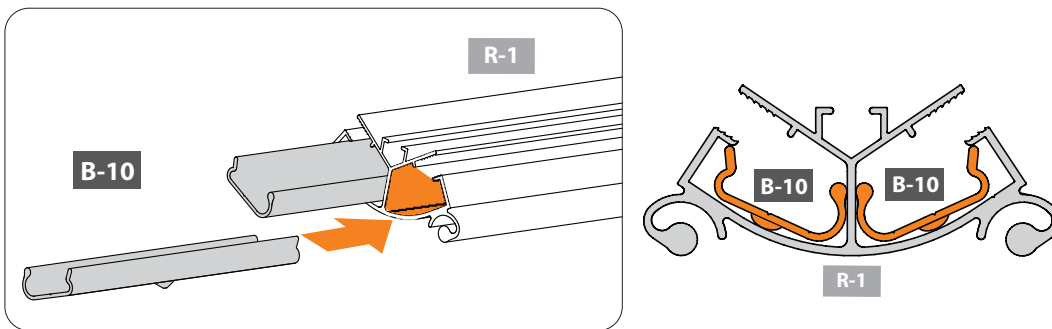

Profile	QTY	Connectors	QTY
	R-1		B-10
	1		2

7.1F

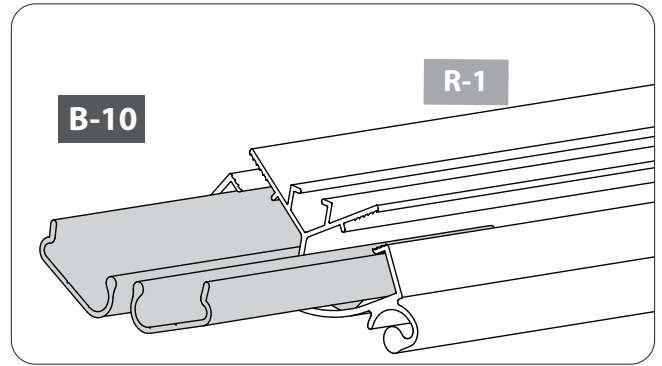
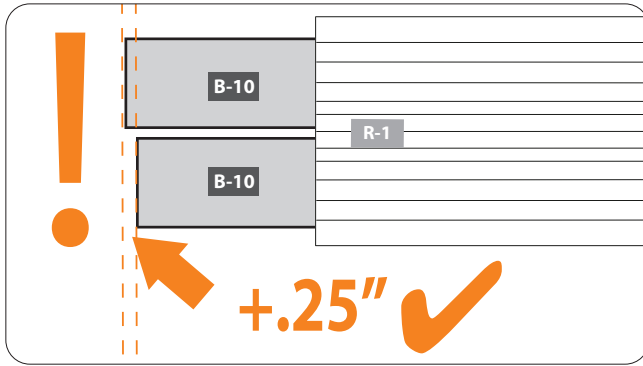
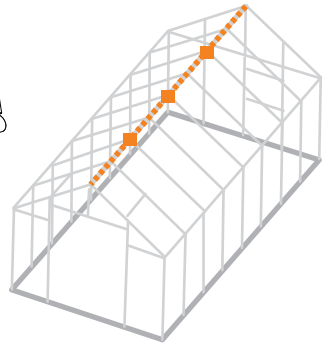
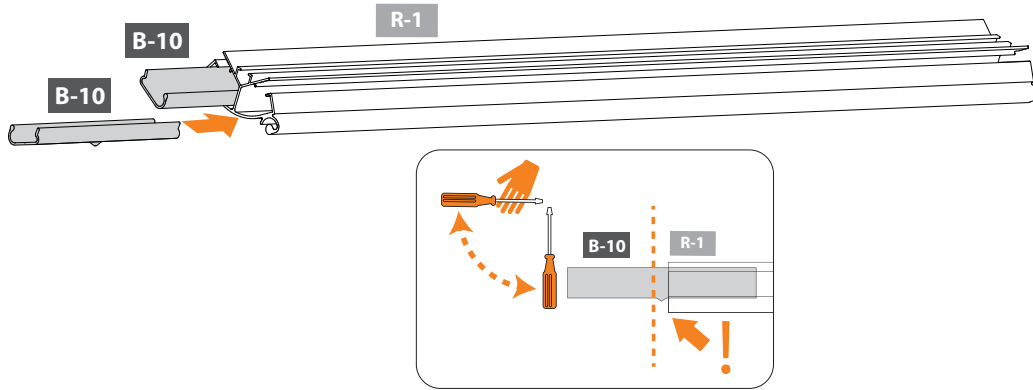

7.1G

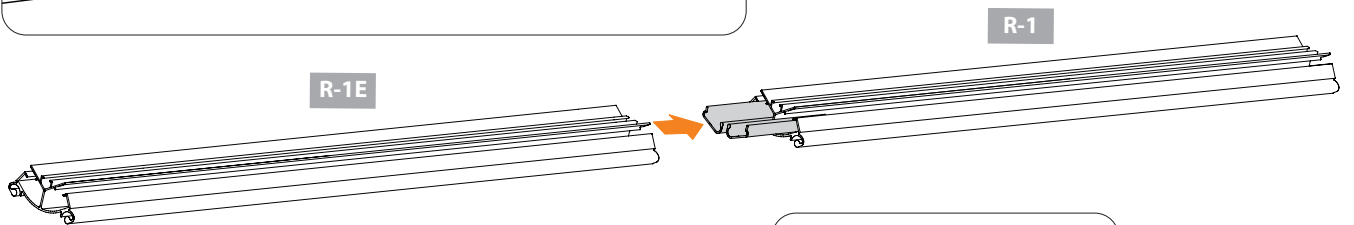
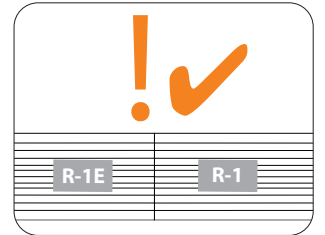
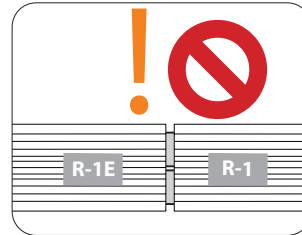
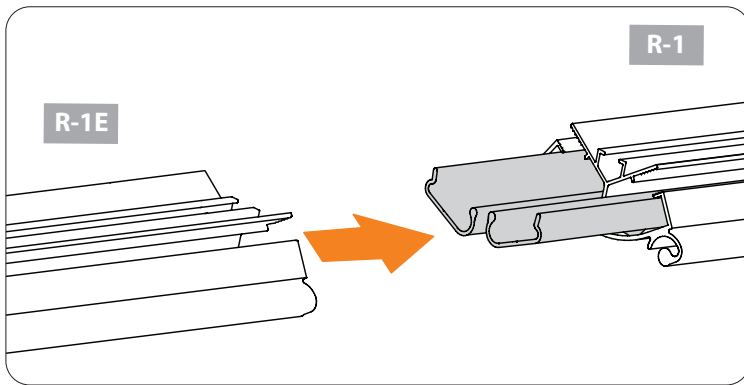

7.1H

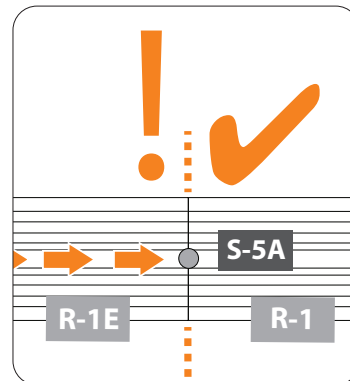
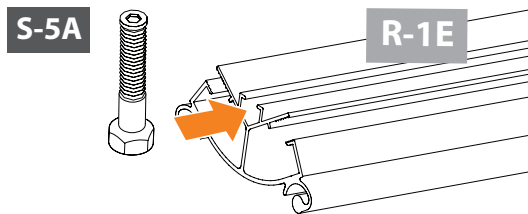

Profile	QTY	Connectors	QTY
	R-1E	1	
			S-5A
			1

7.1I

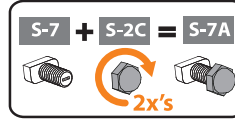
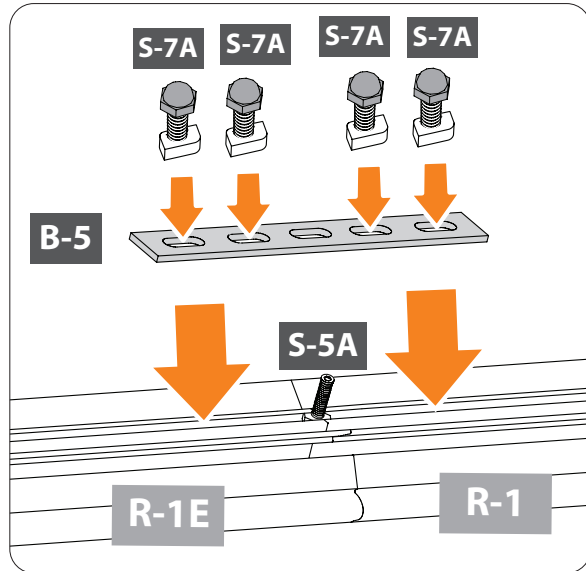
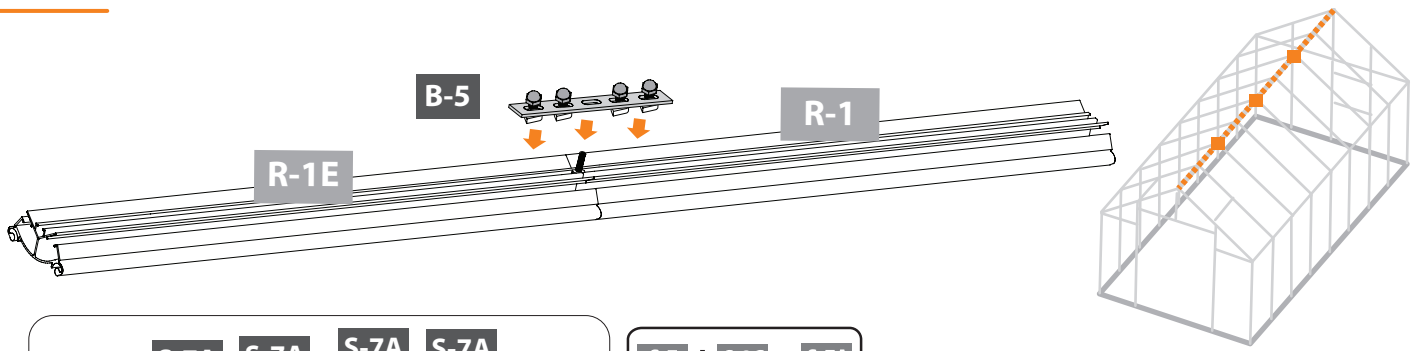

7.1J

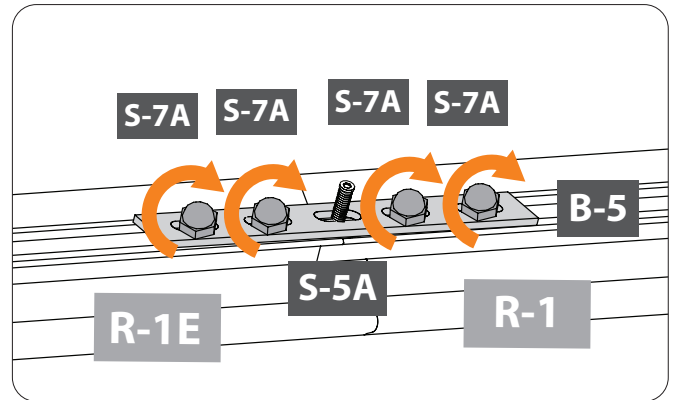

7.2A (7.1A - 7.1J) x 1 R-1E

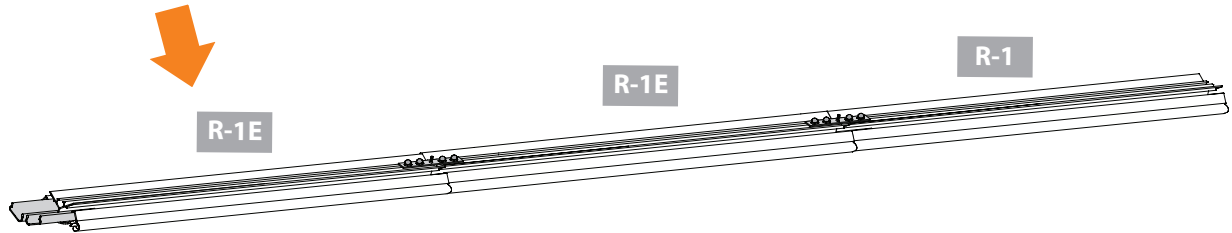

7.2B (7.1A - 7.1J) x 1 R-1

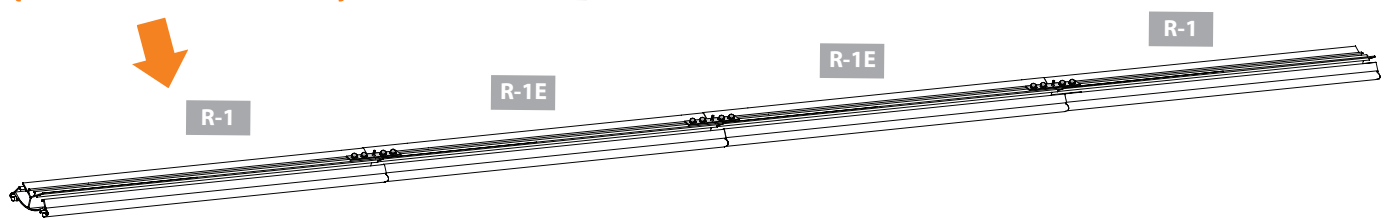

Profile	QTY	Connectors	QTY	Connectors	QTY
	R-1	1		B-10	4
	R-1E	1		S-5	3
				S-7	12
				S-5A	2
				S-2C	12

Pre-Assembly Doors

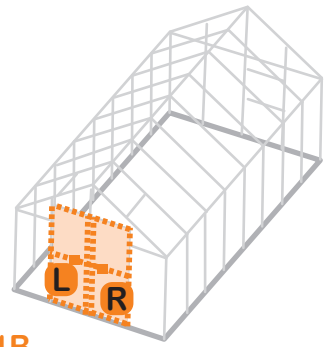
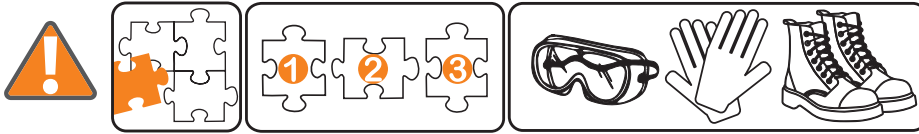

10.1A

R

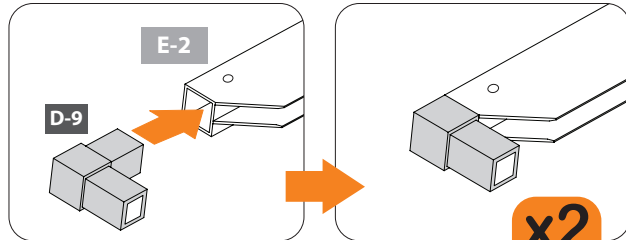
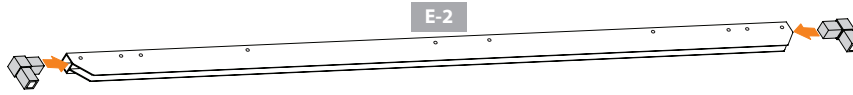

NOTE: E-2 without handle.
REMARQUE: E-2 sans poignée.
NOTA: E-2 sin mango.



Scan This QR Code!
 To be taken to helpful Pro-tips, techniques, and assembly videos!
Reference #09

10.1B

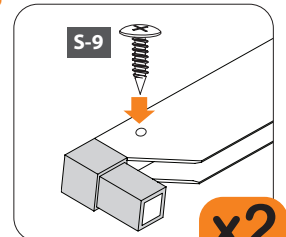

NOTE: Do not over tighten.
REMARQUE: Ne pas trop serrer.
NOTA: No apriete demasiado.

10.1C

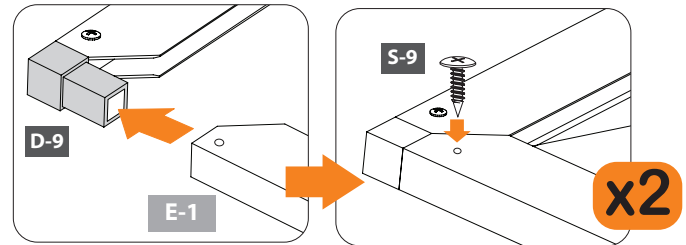
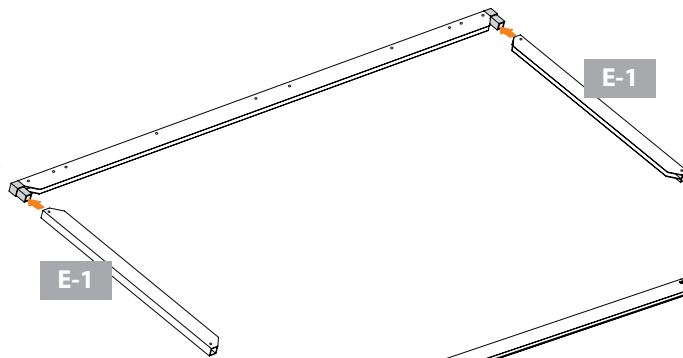



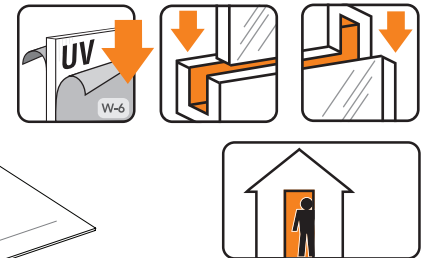
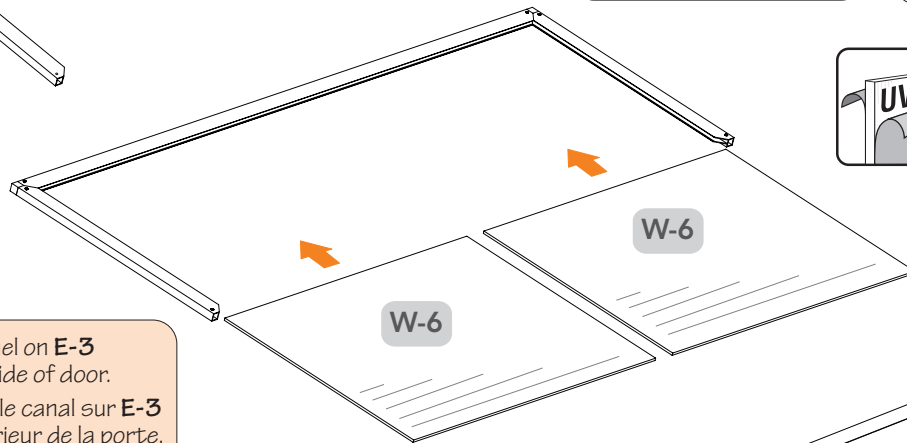

10.1D

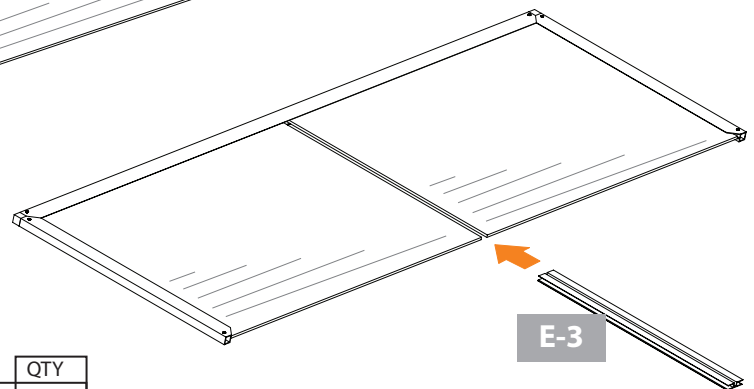
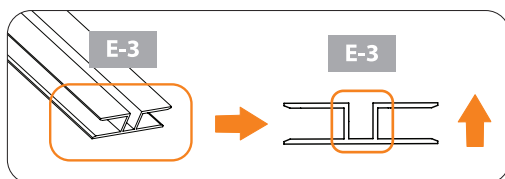

NOTE: Channel on E-3 indicates inside of door.
REMARQUE: le canal sur E-3 indique l'intérieur de la porte.
NOTA: El canal en E-3 indica el interior de la puerta.

10.1E

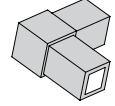

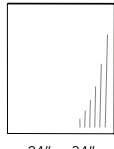
Profile	QTY	Connectors	QTY	Panel	QTY	
 22 1/4"	E-3	1				
 24"	E-1	2		D-9	2	
 68 1/2"	E-2	1		S-9	4	
					W-6	2
				24" x 34"		

10.2A

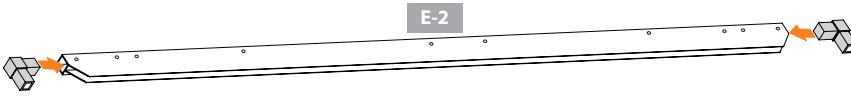

NOTE: E-2 with handle.
REMARQUE: E-2 avec poignée.
NOTA: E-2 con asa.

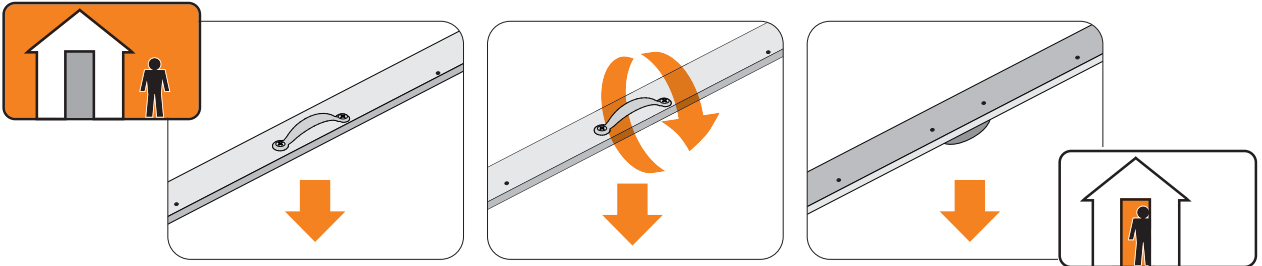
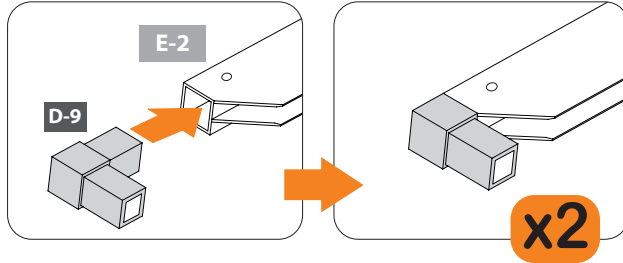

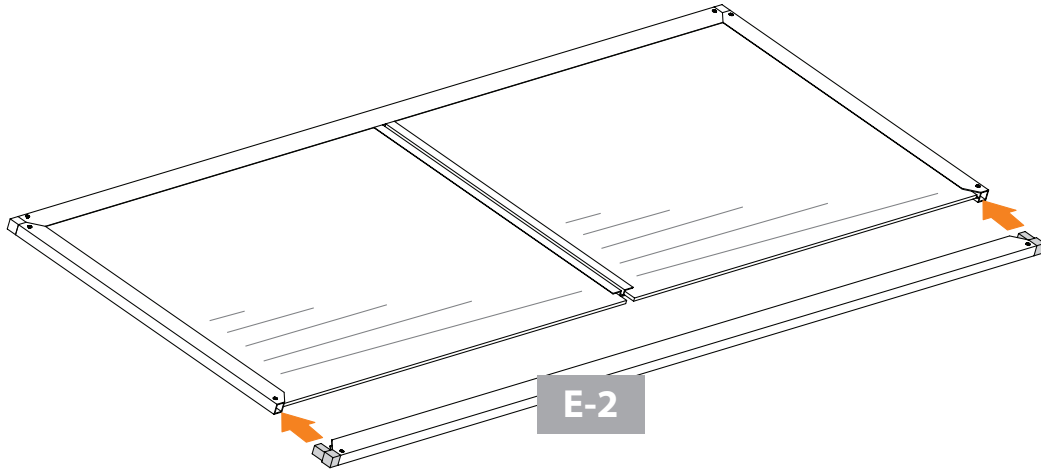

10.2B

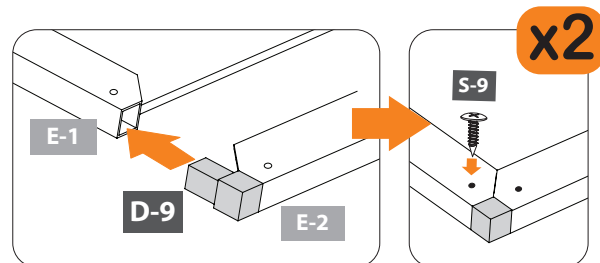

NOTE: Channel on E-3 indicates inside of door.
REMARQUE: le canal sur E-3 indique l'intérieur de la porte.
NOTA: El canal en E-3 indica el interior de la puerta.

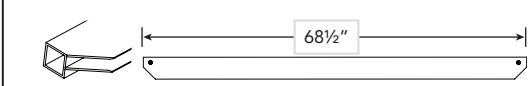

Profile	QTY	Connectors		QTY
	E-2		D-9	2
			S-9	4

10.2C

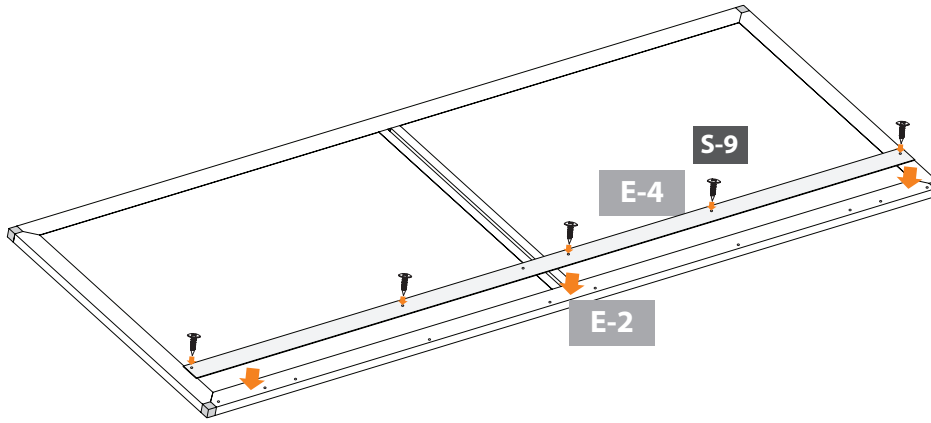
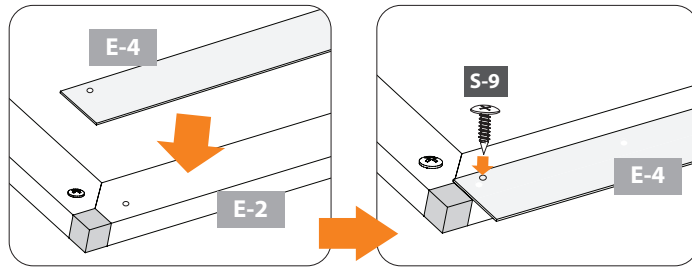

10.3A

L (10.1A - 10.2A) x 1

10.3B

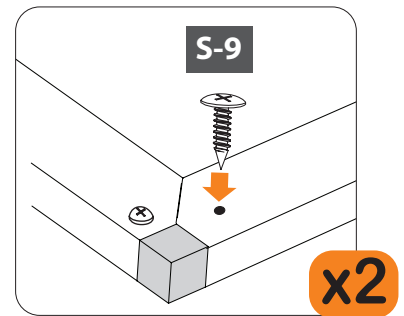
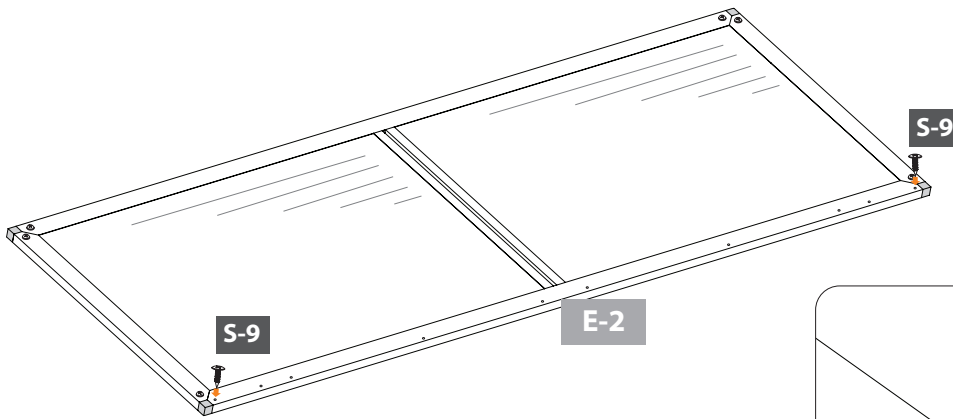

Profile		QTY
	22 1/4"	E-3 1
	24"	E-1 2
	68 1/2"	E-2 1
	68 1/2"	E-4 1

Connectors	QTY	Panel	QTY
	D-9 2		W-6 2
	S-9 9		

Assemble Base

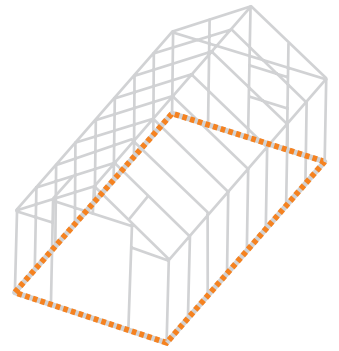
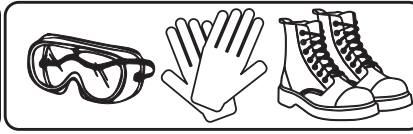
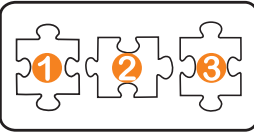

1.1A

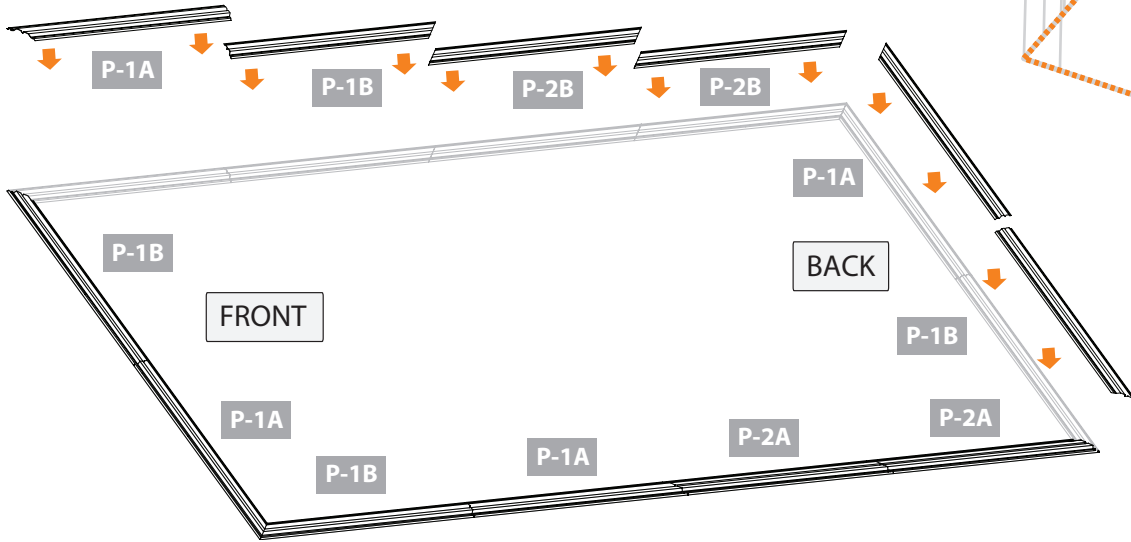

IMPORTANT: Make sure the base fits properly on your foundation. If not, stop and fix your foundation.

IMPORTANT: Assurez-vous que la base s'adapte correctement à votre fondation. Sinon, arrêtez et réparez votre fondation.



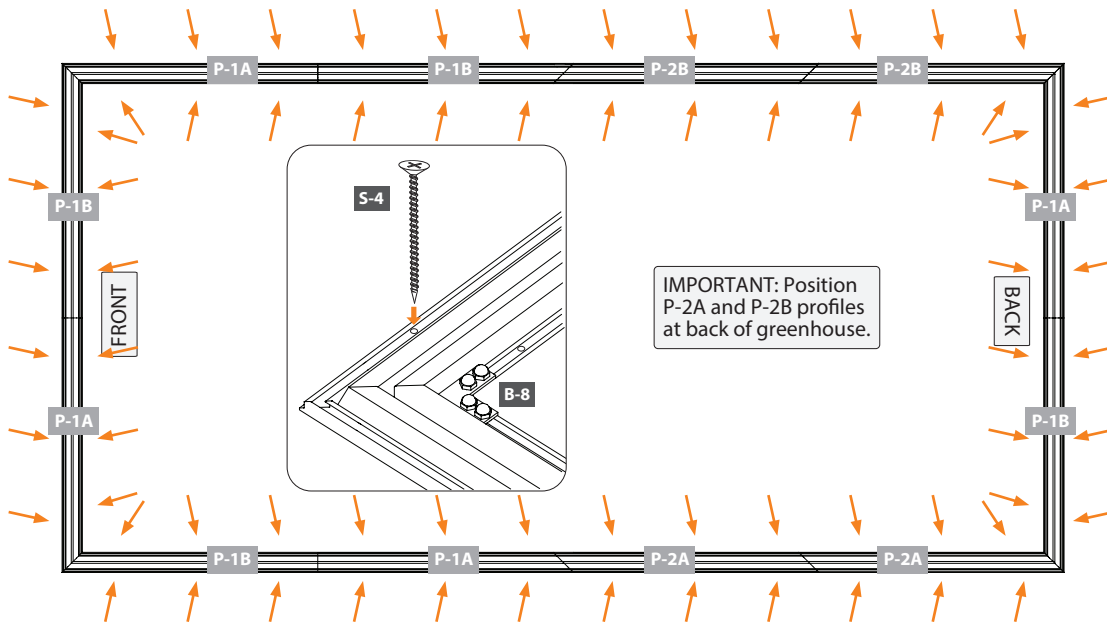

IMPORTANTE: Asegúrese de que la base se ajuste correctamente a su base. Si no es así, deténgase y arregle su base.

1.1B

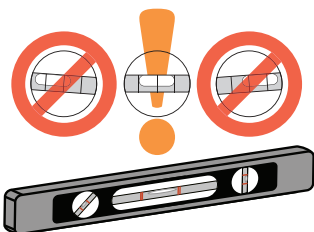
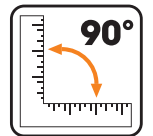
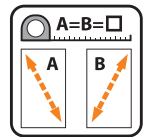

IMPORTANT: Position P-2A and P-2B profiles at back of greenhouse.



Connector		QTY	Profile	QTY	
	S-4	80	 50 1/2"	P-1A	4
				P-1B	4
 52 1/8"				P-2A	2
				P-2B	2

1.2A

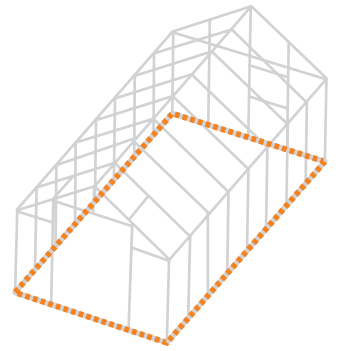
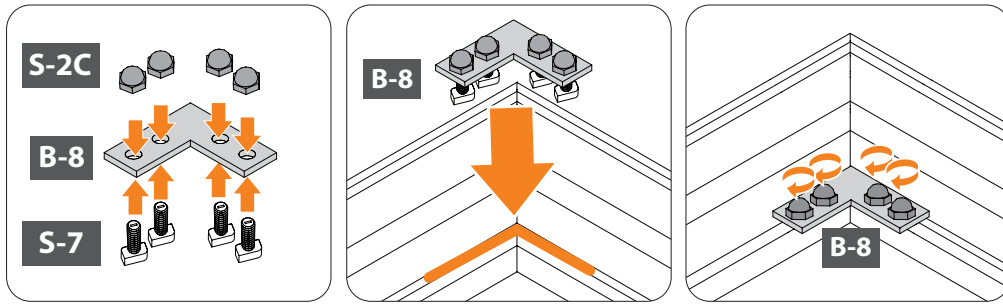

B-8 x4

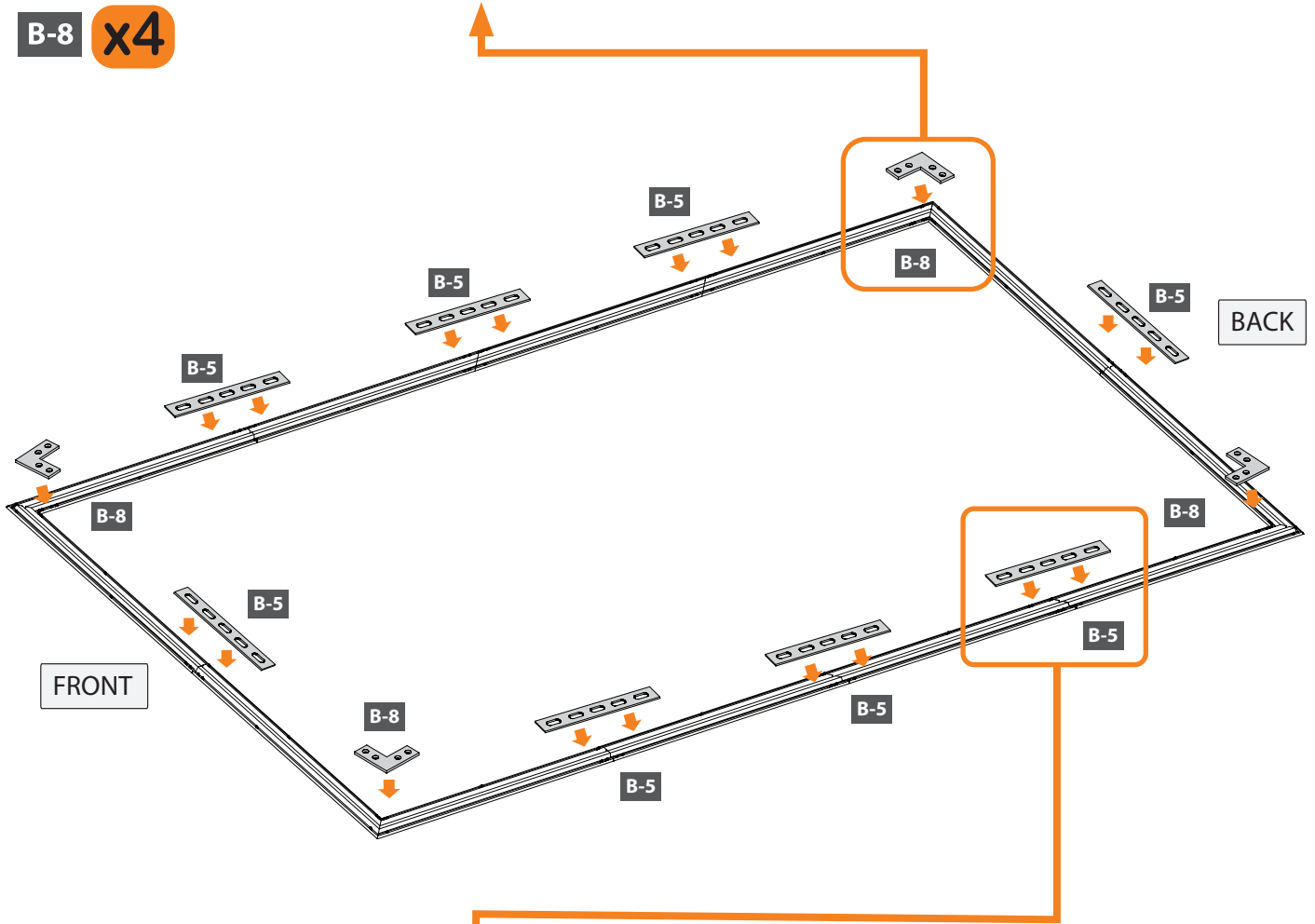

1.2B

B-5 x8

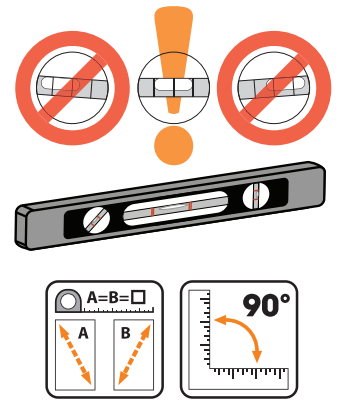
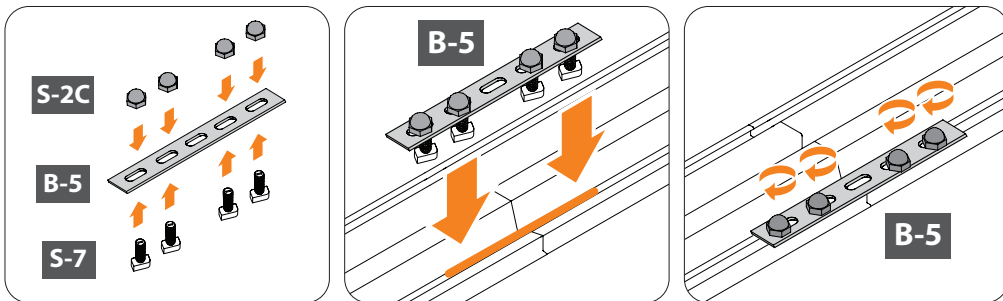

Connectors		QTY	Connector		QTY	Connector		QTY	Connector		QTY
	S-7	48		B-5	8		B-8	4		S-2C	48

Assemble Right Wall

CHECK YOUR WEATHER FORECAST. DO NOT CONTINUE ASSEMBLY DURING WINDS.

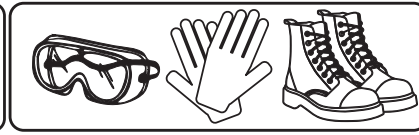
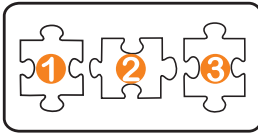
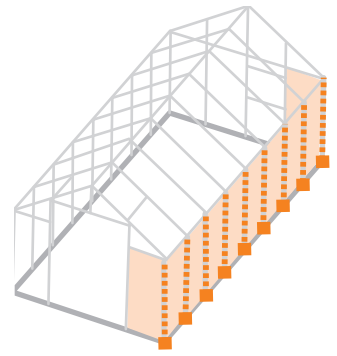

2.1A

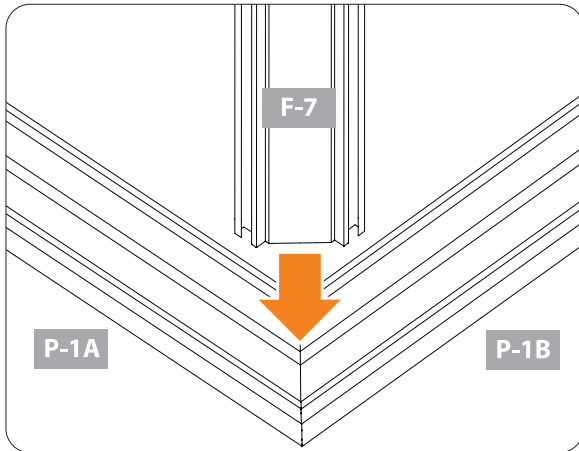

2.1B

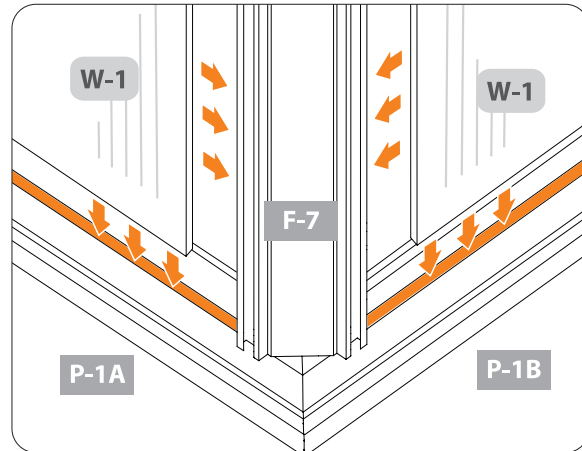

2.1C

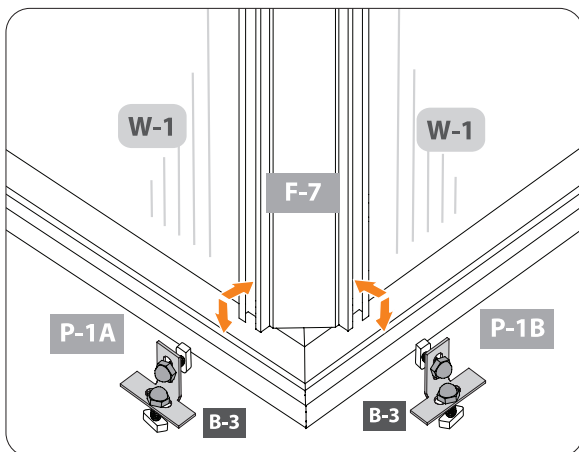

2.1D

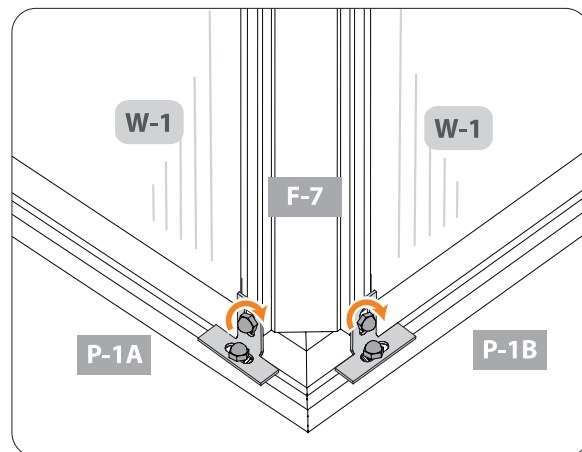

2.1E

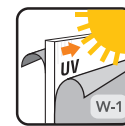
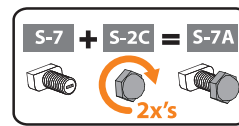
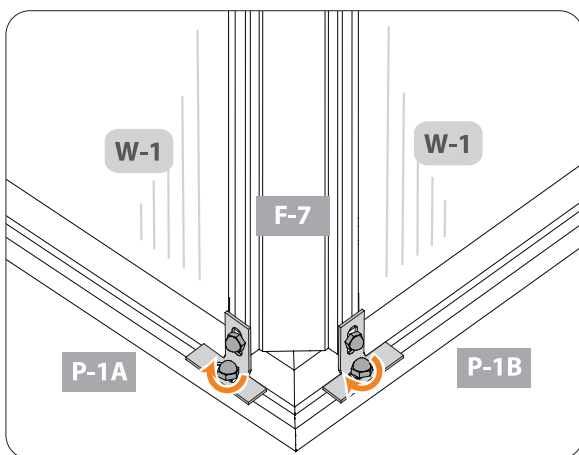

Panel	QTY	Profile	QTY	Connectors	QTY	
	W-1	2		F-7	1	
					B-3	2
					S-2C	4
					S-7	4

2.2A

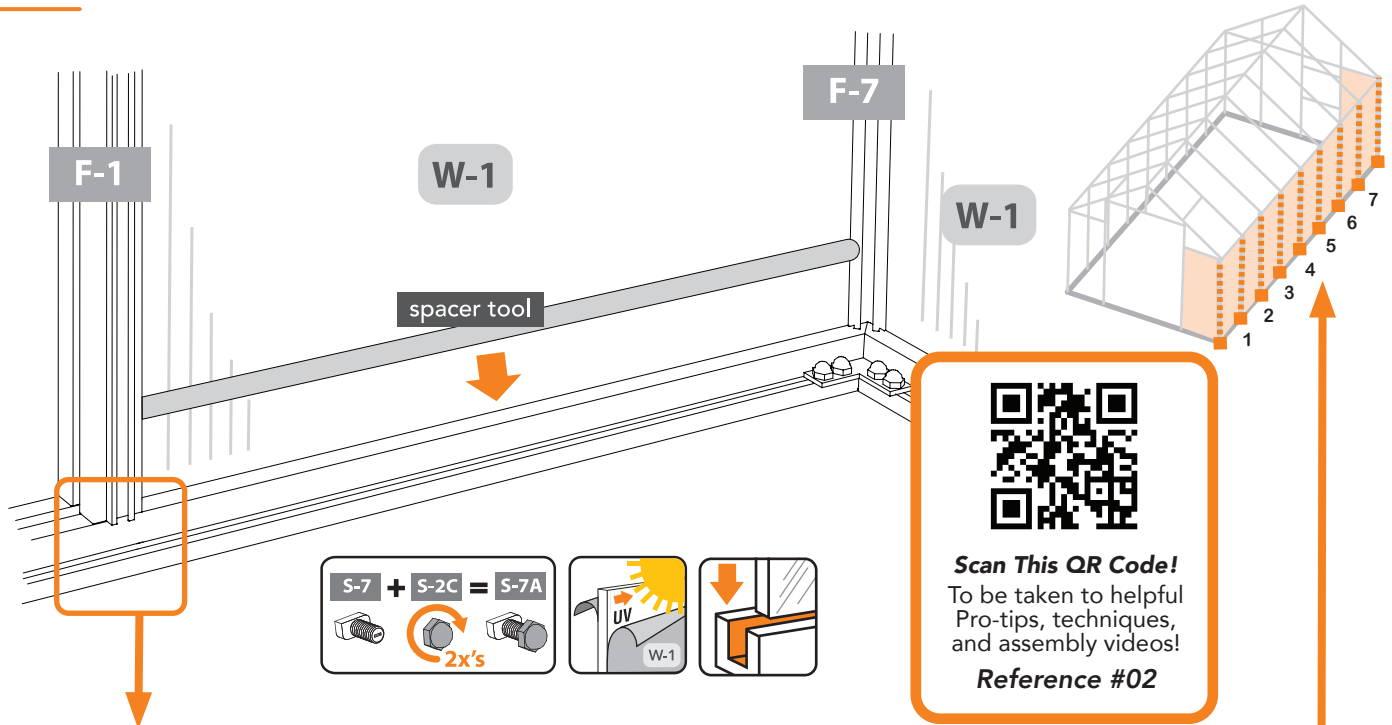

2.2B

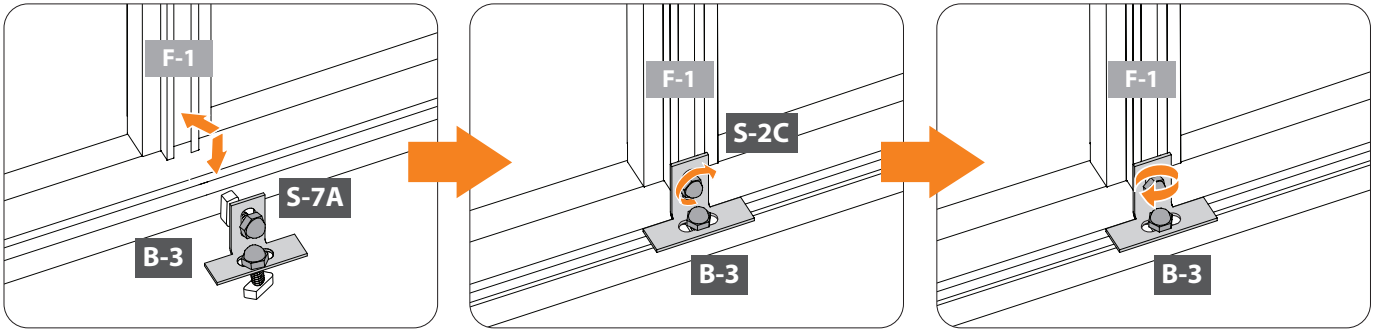

(2.2A - 2.2B) x 7





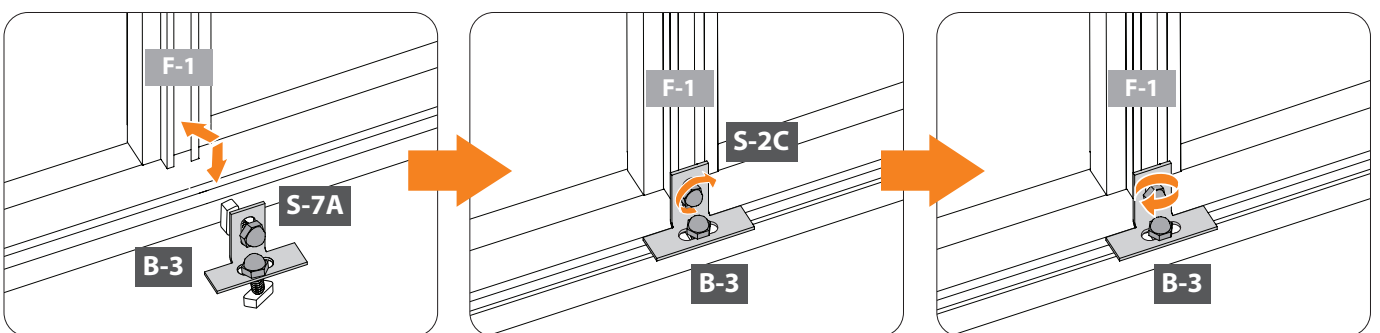

2.2C

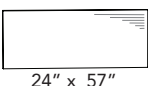

x7



Panel	QTY	Profile	QTY	Connectors	QTY			
 24" x 57"	W-1	7		56"	F-1	7	 B-3  S-2C  S-7	14 28 28

2.3A

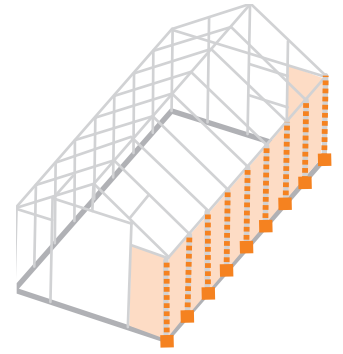
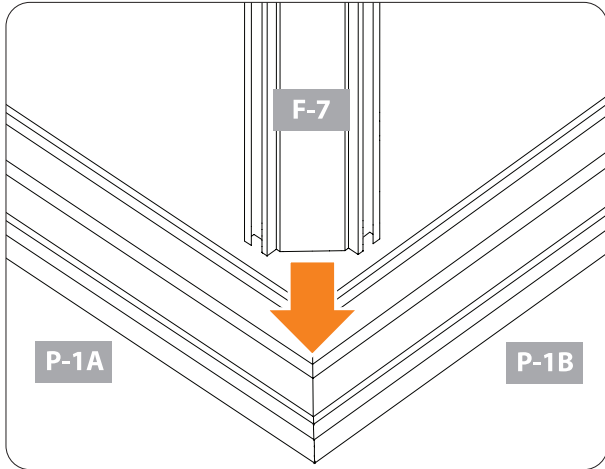

2.3B

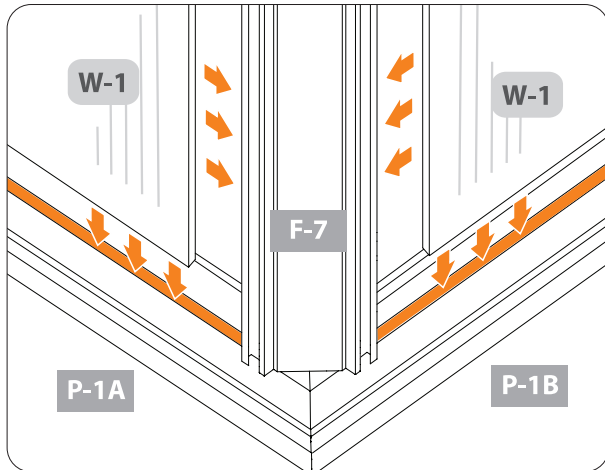

2.3C

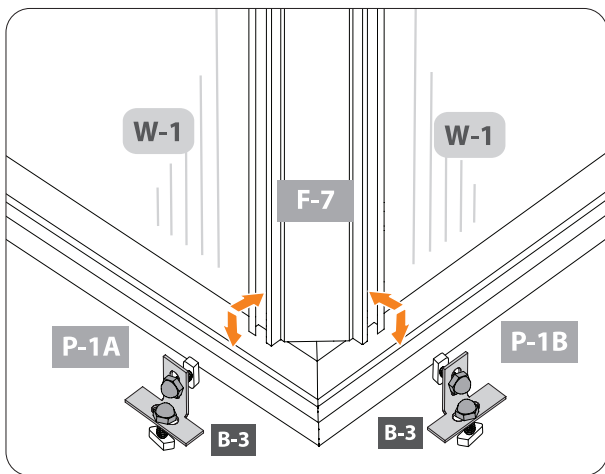



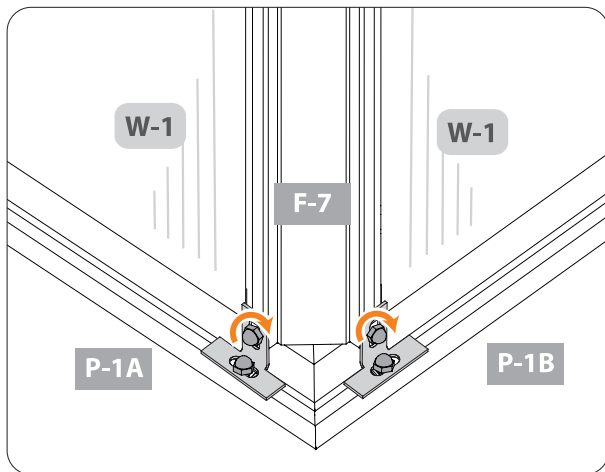

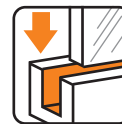
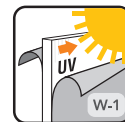
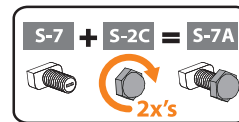
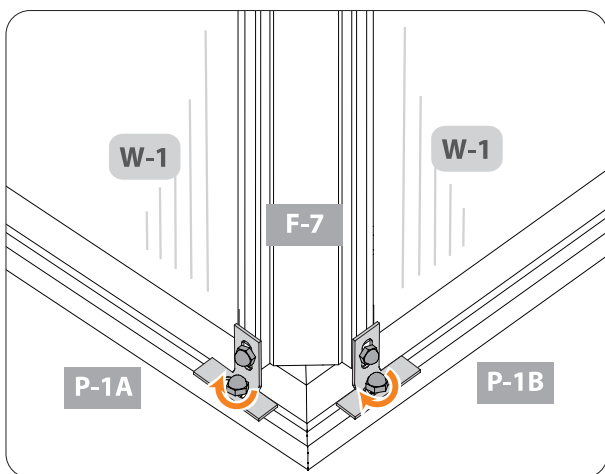

2.3D

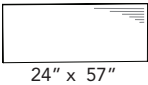

2.3E



Panel	QTY	Profile	QTY	Connectors	QTY	
 24" x 57"	W-1	1			B-3	2
					S-2C	4
			F-7		S-7	4

Install Pre-Assembled Gutter

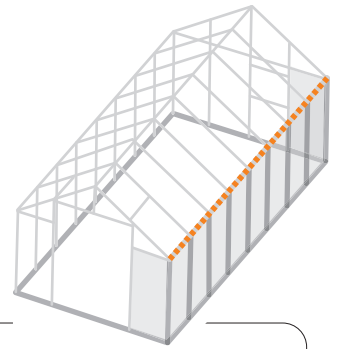
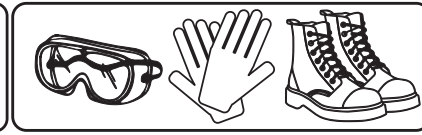
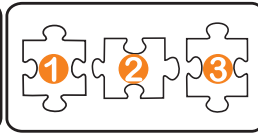

(2.4A - 2.5I) x 1 (see page 29)

2.6A

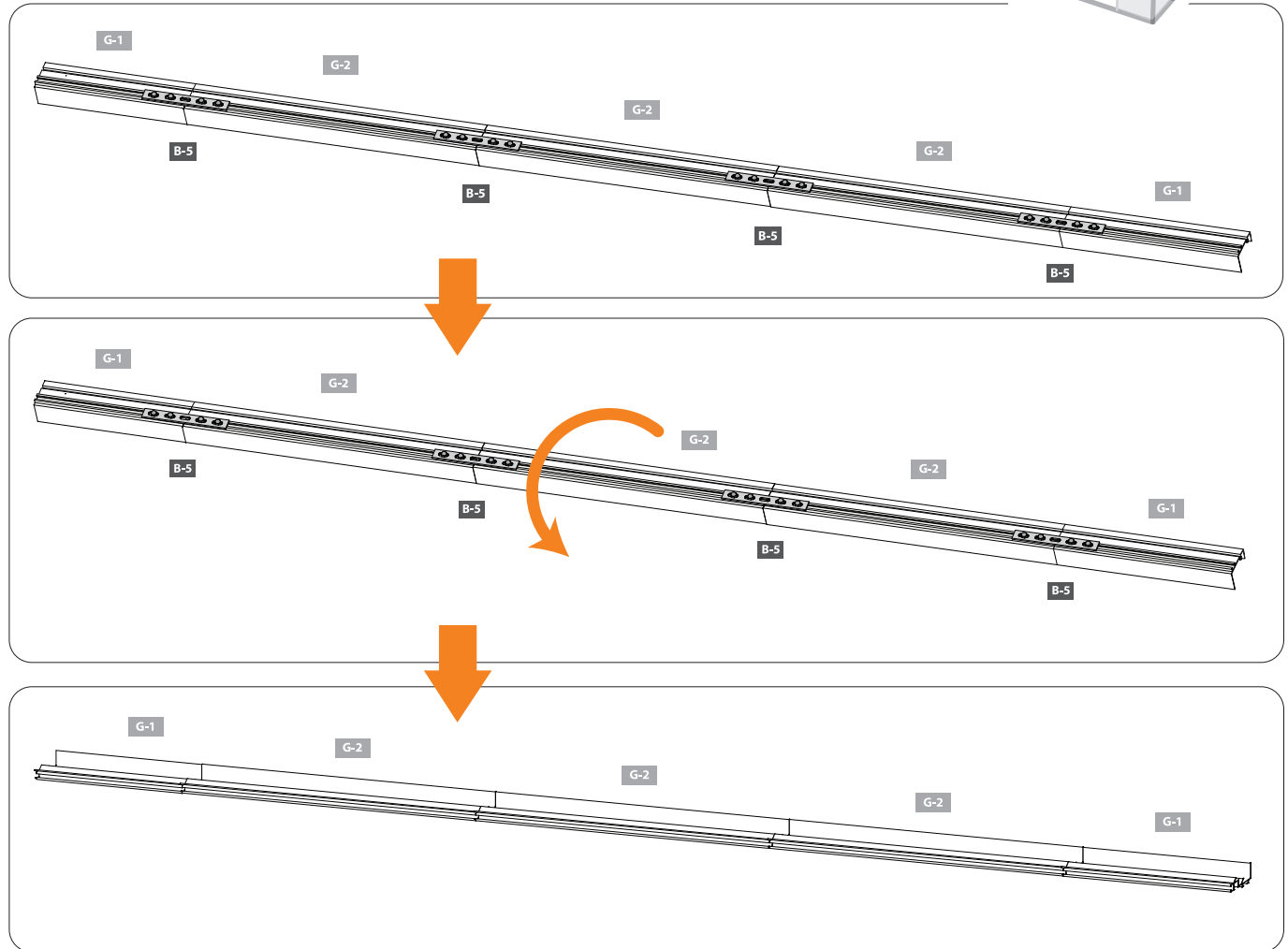

2.6B

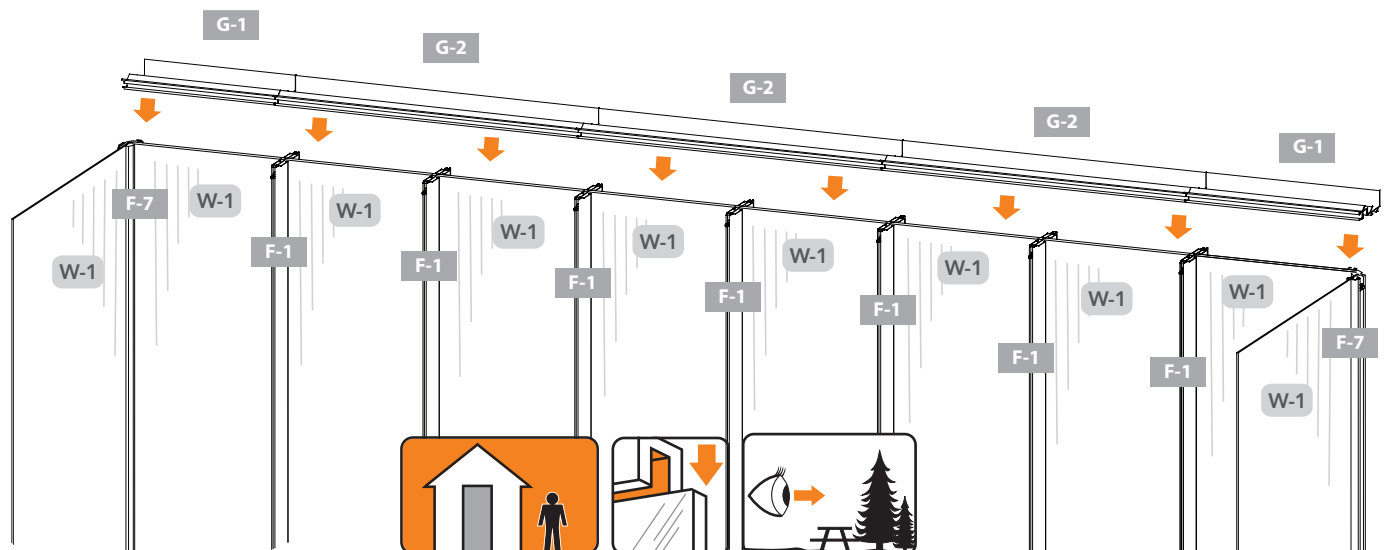

2.6C

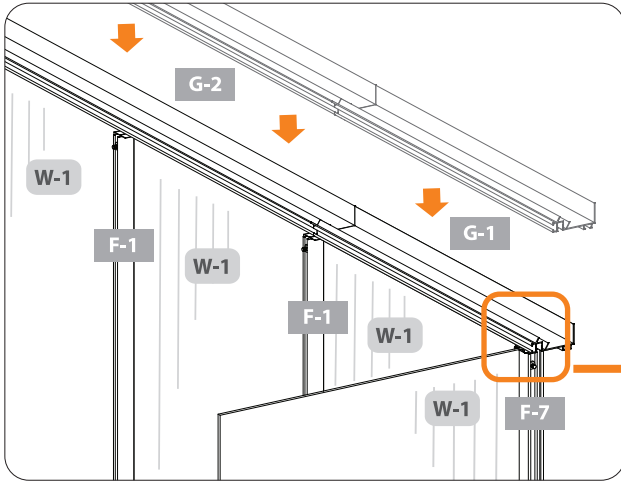

Scan This QR Code!
To be taken to helpful
Pro-tips, techniques,
and assembly videos!
Reference #05

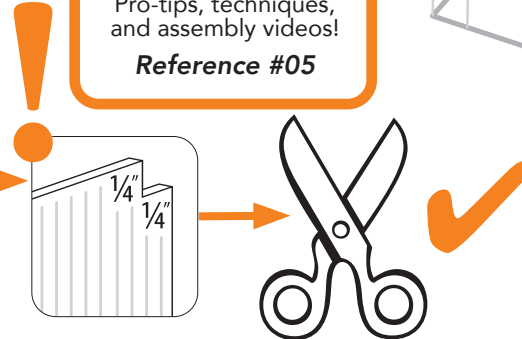
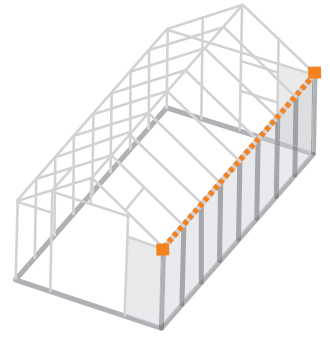

1 FRONT

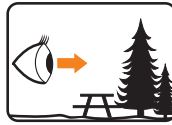

REAR 2

2.6D

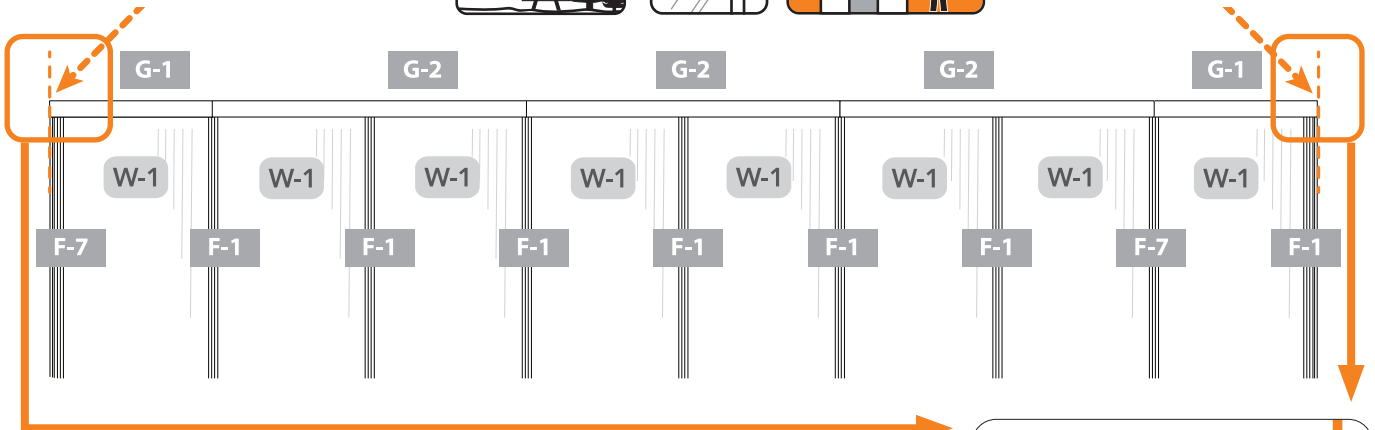

1 & 2

NOTE: At front and back, edge of G-1 gutter profile lines up flush with edge of F-7 corner profile.
REMARQUE: À l'avant et à l'arrière, le bord du profilé de gouttière G-1 est aligné avec le bord du profilé d'angle F-7.
NOTA: En la parte delantera y trasera, el borde del perfil de canalón G-1 se alinea al ras con el borde del perfil de esquina F-7.

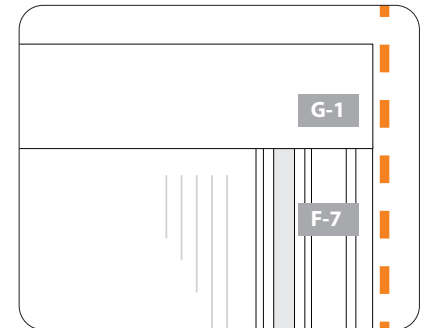

2.6E

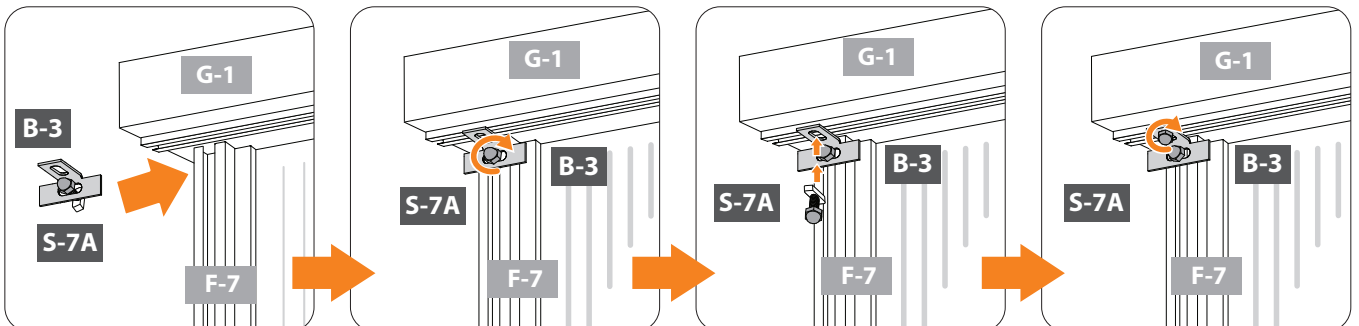

Connectors	QTY	Connectors	QTY	Connectors	QTY
	B-3	2		S-2C	4
				S-7	4

3 5 7 9 : (2.8A - 2.8F)

4 6 8 : (2.7A - 2.7D)

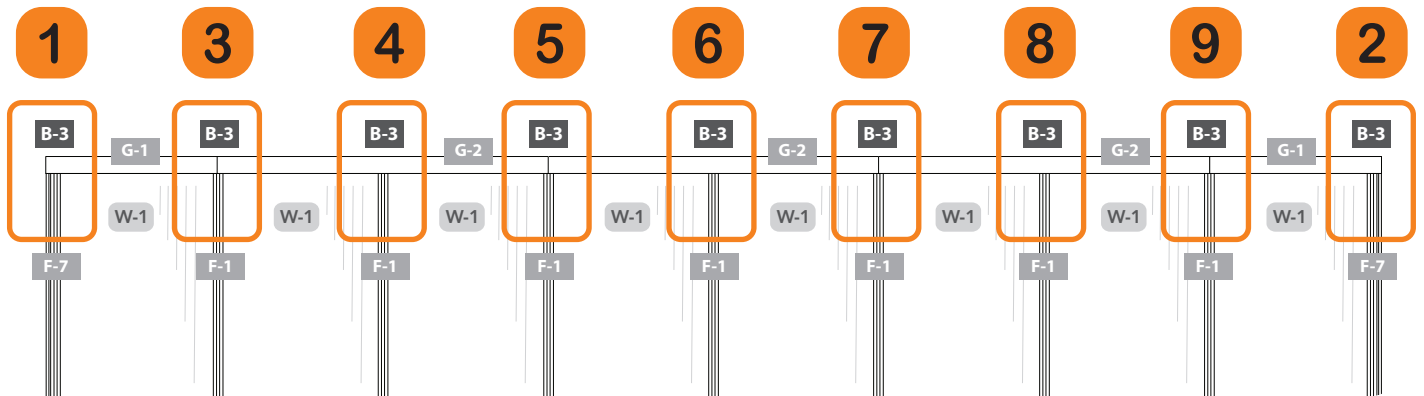
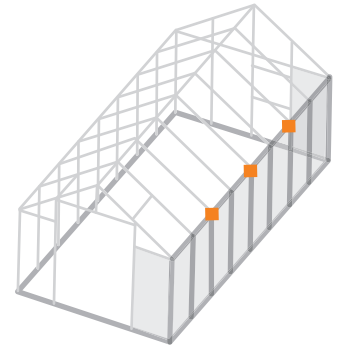

2.7A

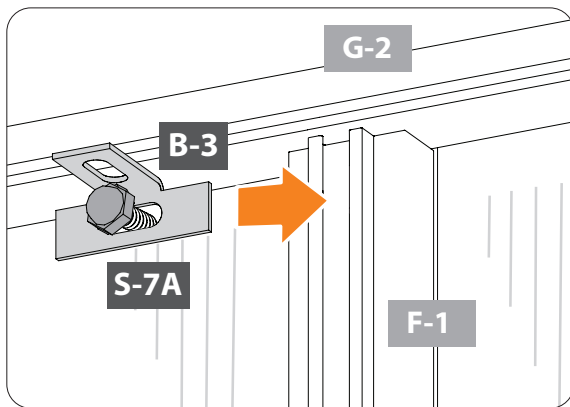

2.7B

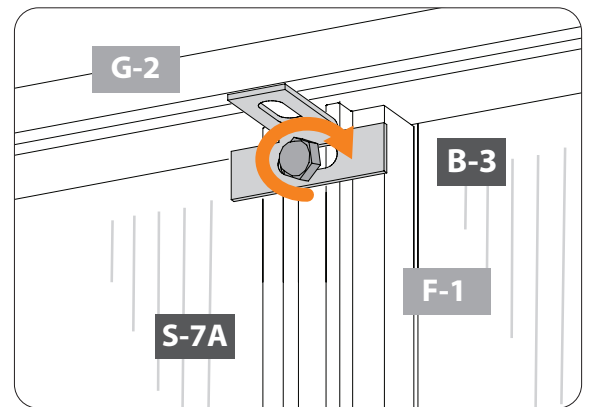

2.7C

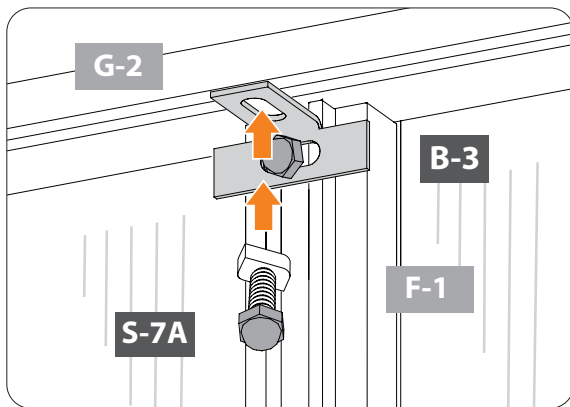

2.7D

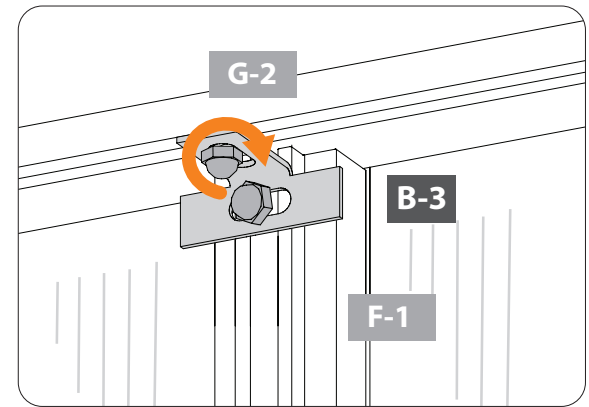

2.7E (2.7A - 2.7D) x 3

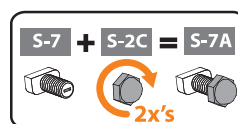

Connectors	QTY
B-3	3
S-2C	6
S-7	6

2.8A

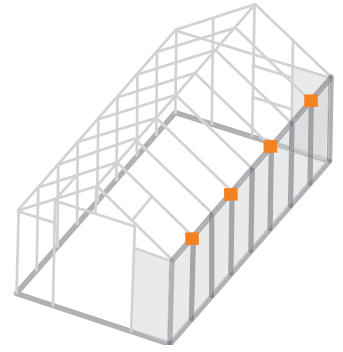
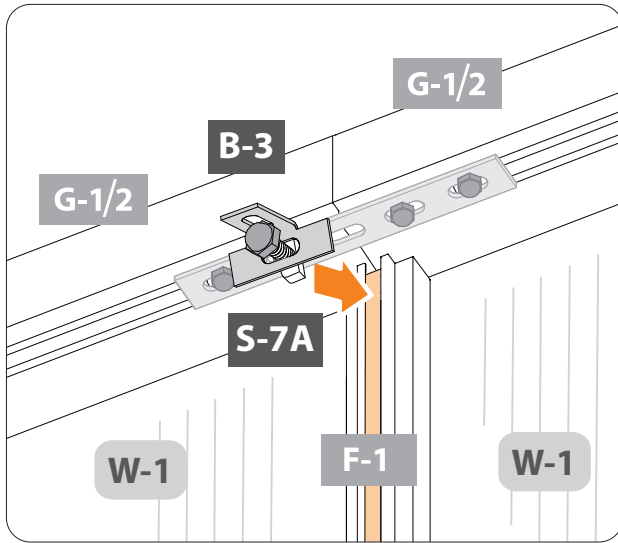

2.8B

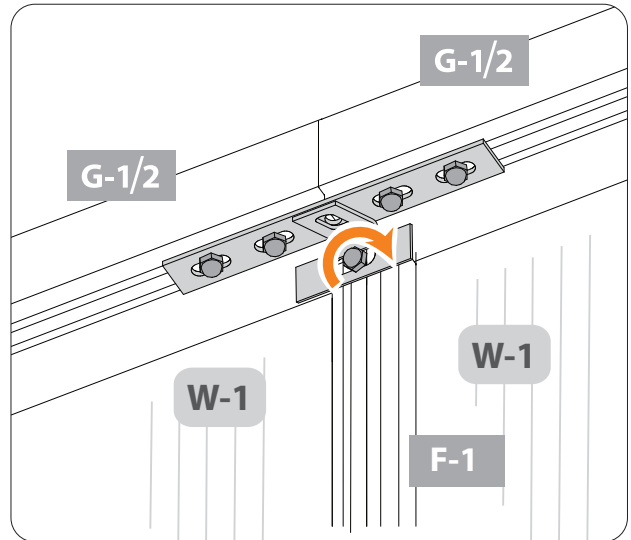

2.8C

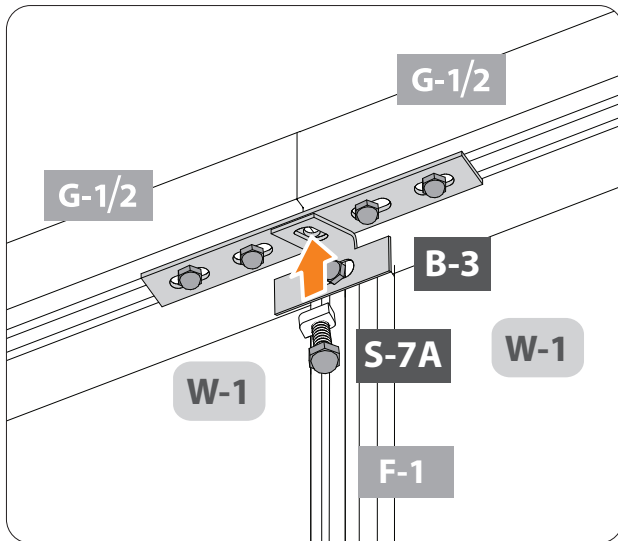

2.8D

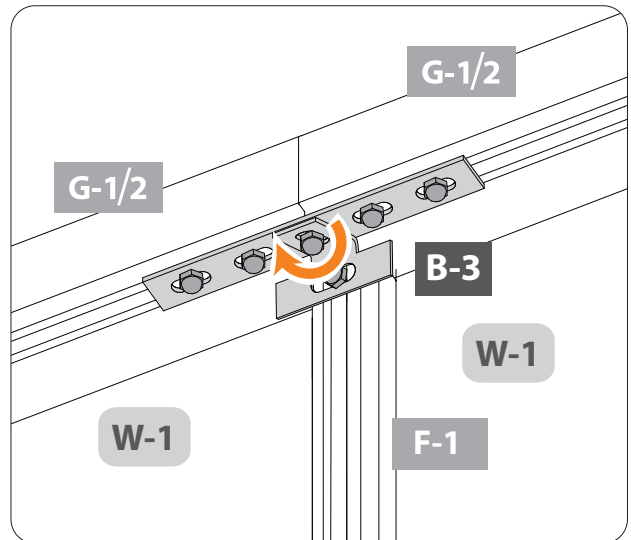

2.8E (2.8A - 2.8D) x 4

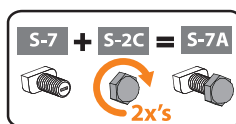

Connectors		QTY
	B-3	4
	S-2C	8
	S-7	8

Assemble Back Wall

CHECK YOUR WEATHER FORECAST. DO NOT CONTINUE ASSEMBLY DURING WINDS.

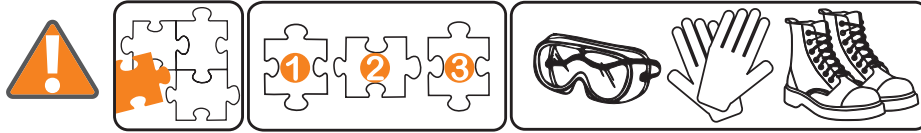
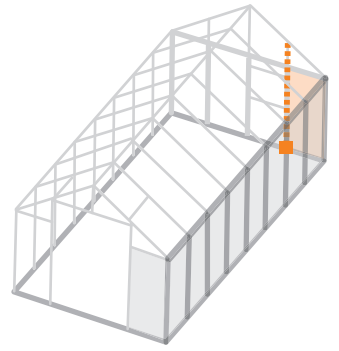

3.1A

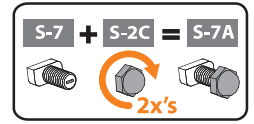
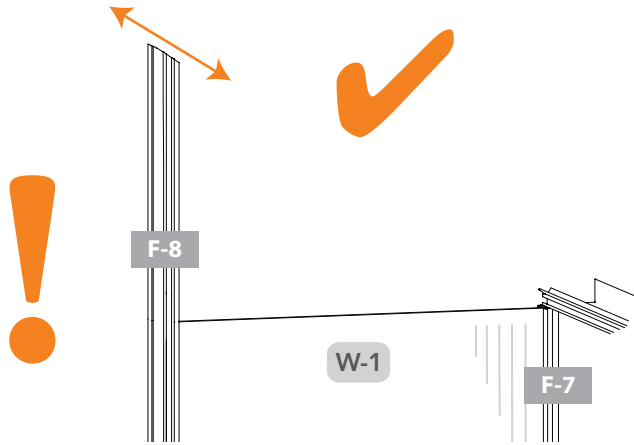

3.1B

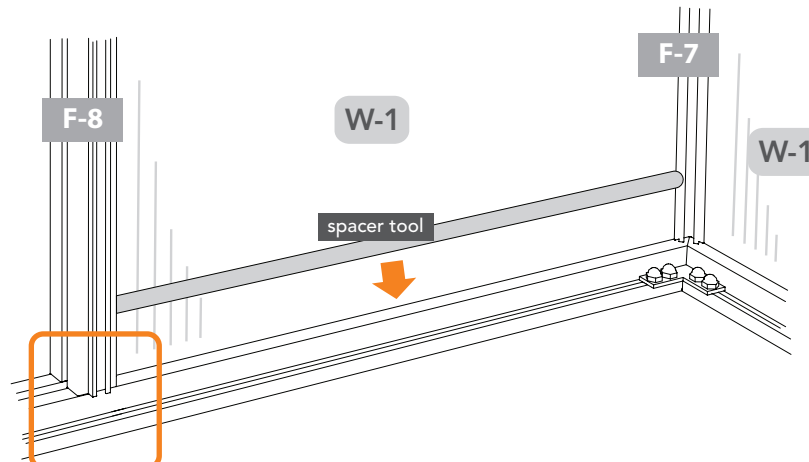

3.1C

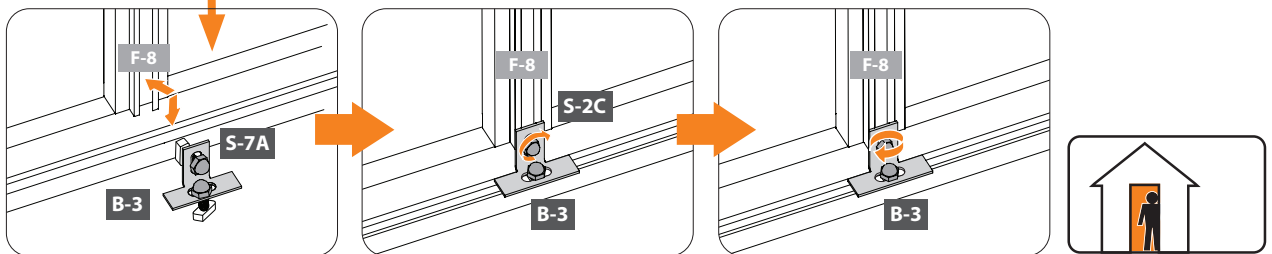

3.1D

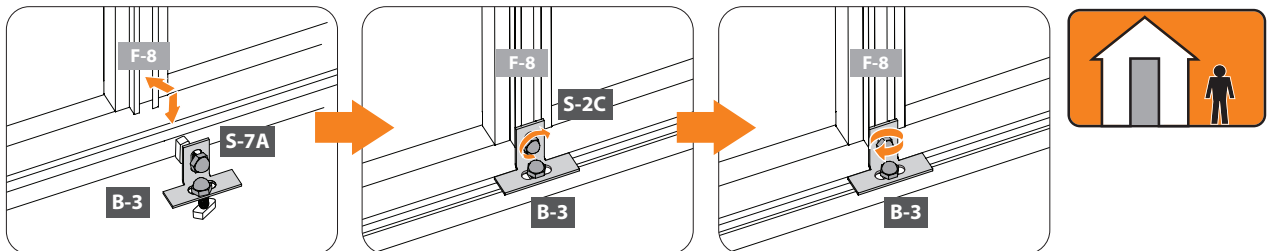

Profile	QTY	Connector	QTY
	1		2
F-8	1		4
			4

3.1E

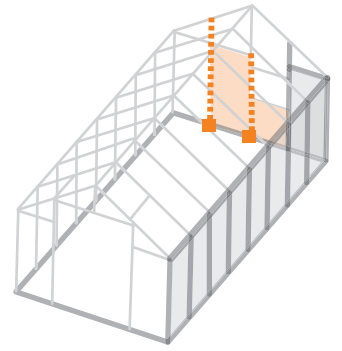
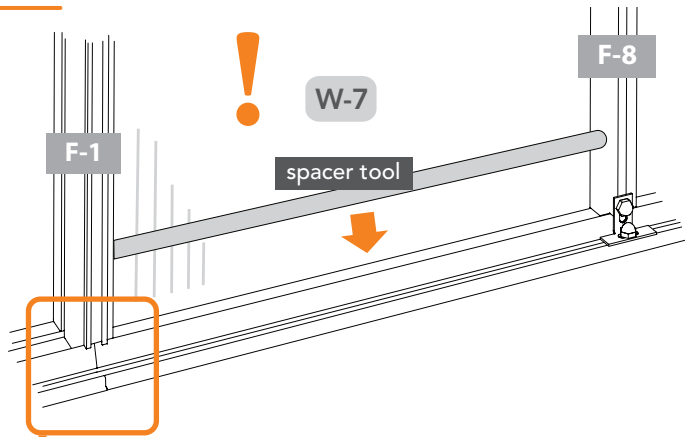

3.1F

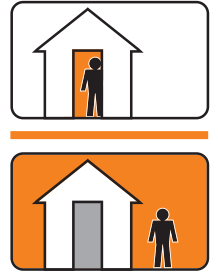
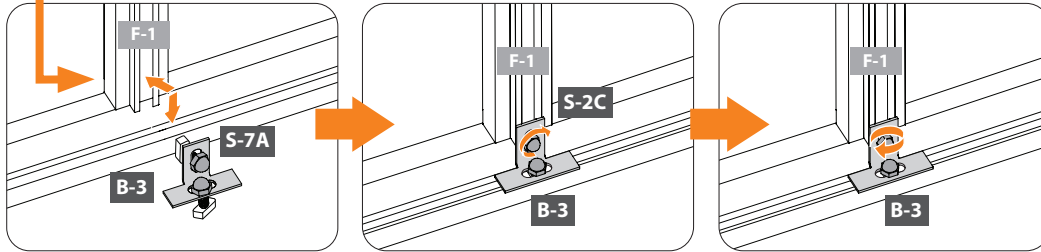

3.1G

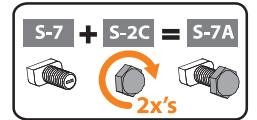
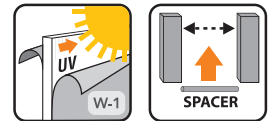
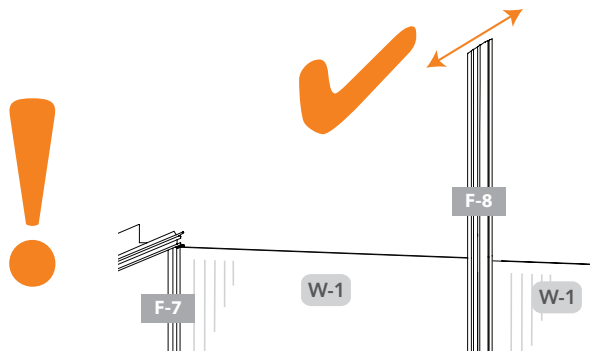

3.1H

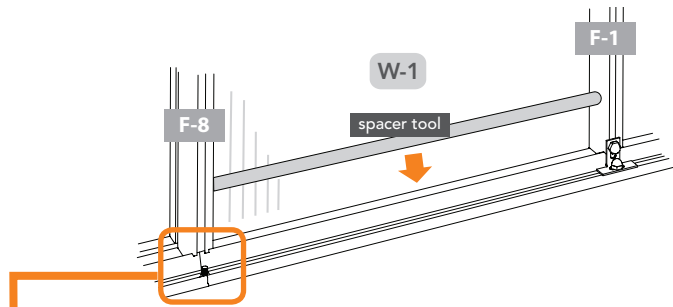

3.1I

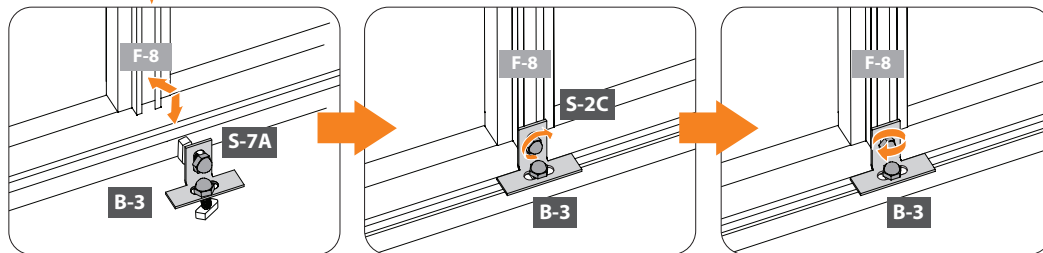

Profile	QTY	Panels	QTY	Connector	QTY
	1		1		4
	1		1		8

3.2A

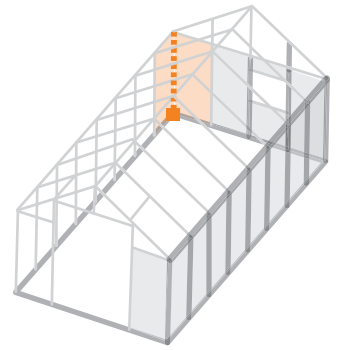
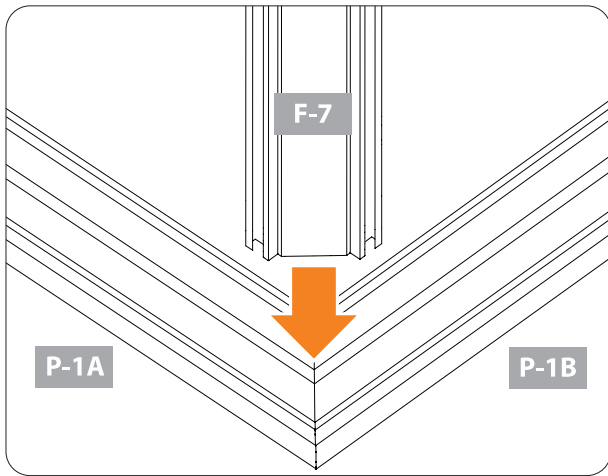

3.2B

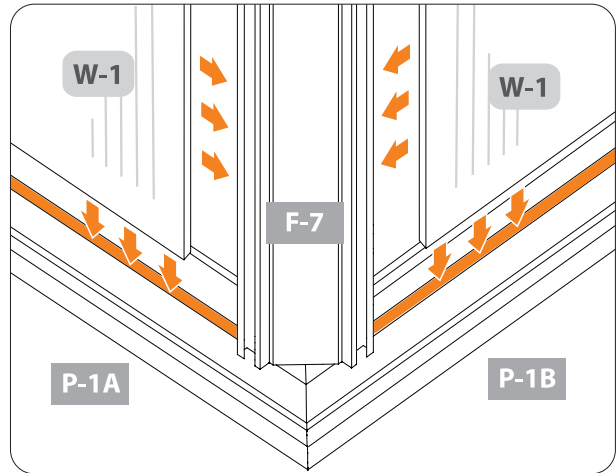

3.2C

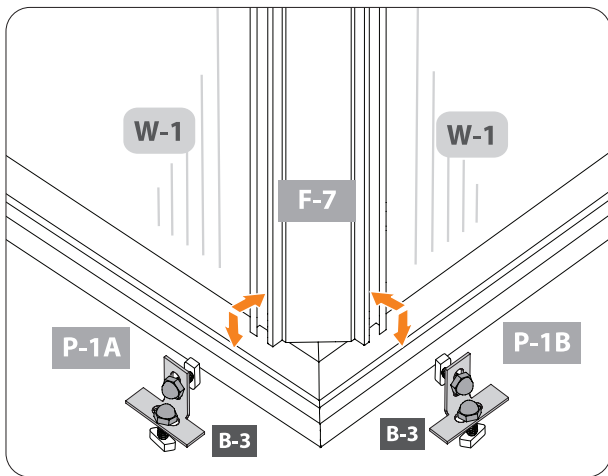

3.2D

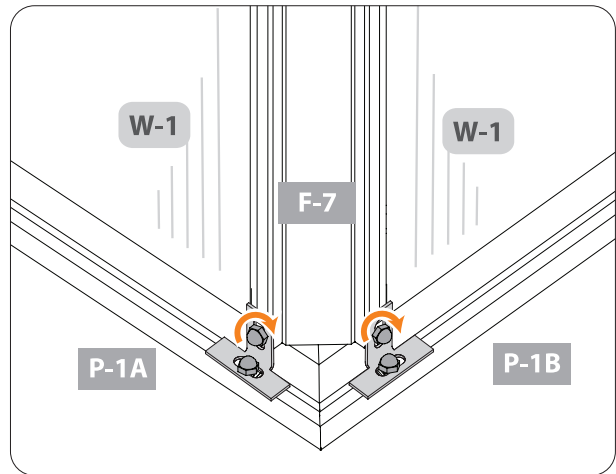

3.2E

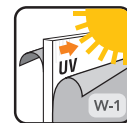
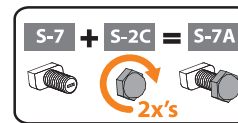
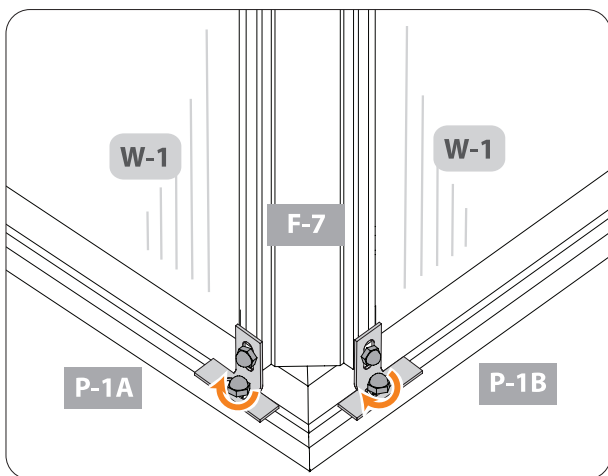

Profile	QTY	Panel	QTY	Connector	QTY		
	F-7	1		W-1	2		B-3 2 S-2C 4 S-7 4

3.3A

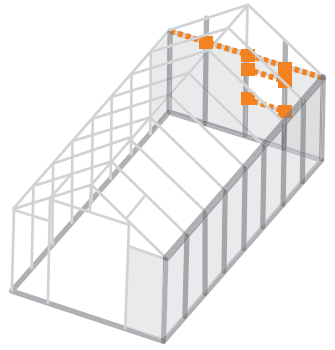
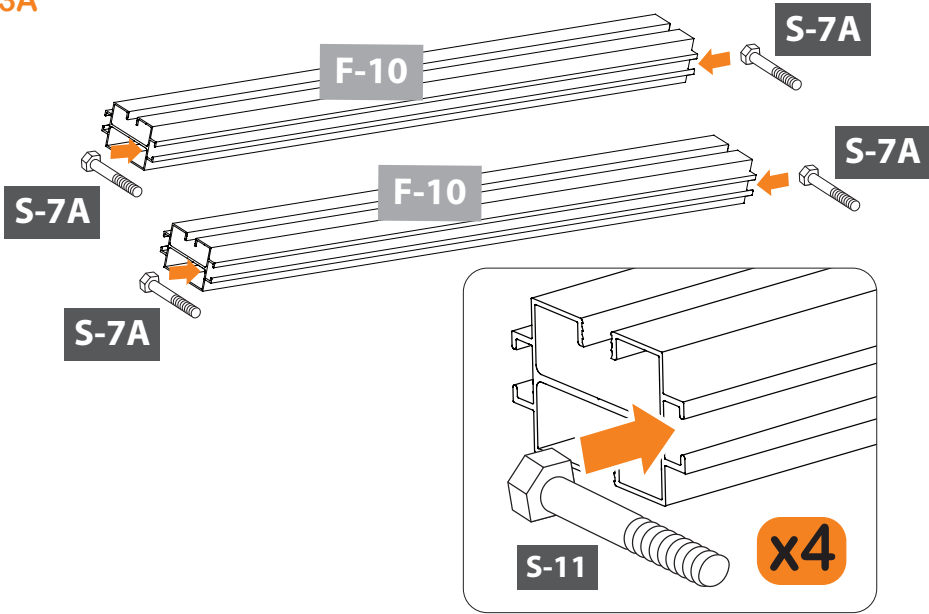

3.3B

Scan This QR Code!
 To be taken to helpful
 Pro-tips, techniques,
 and assembly videos!
Reference #10

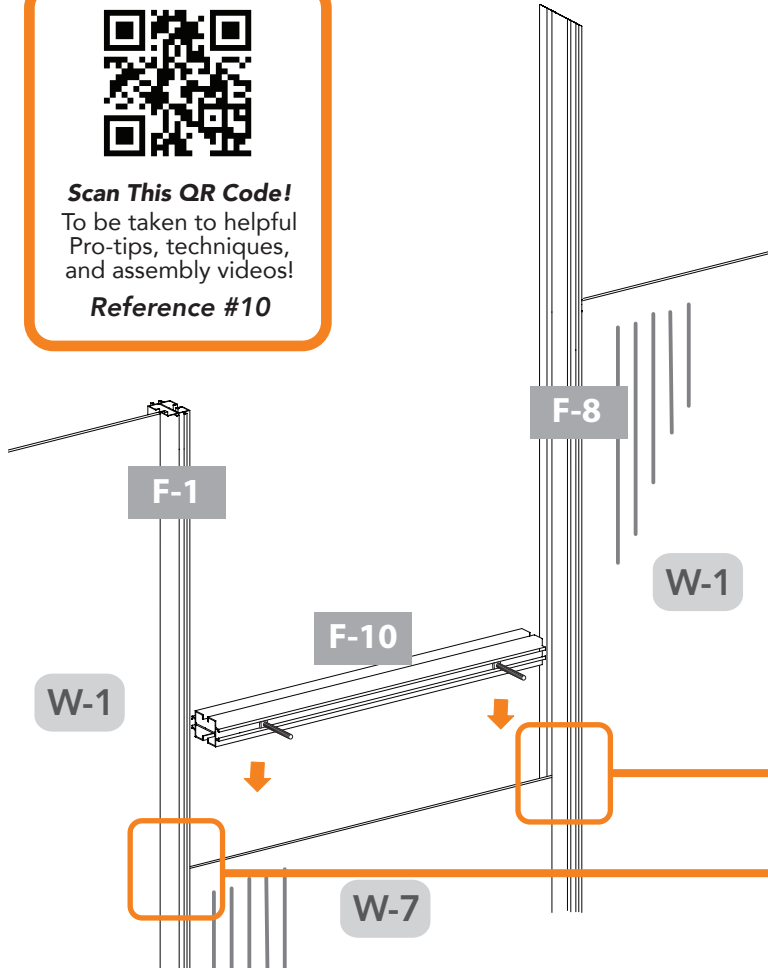

3.3C

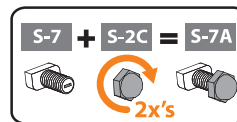
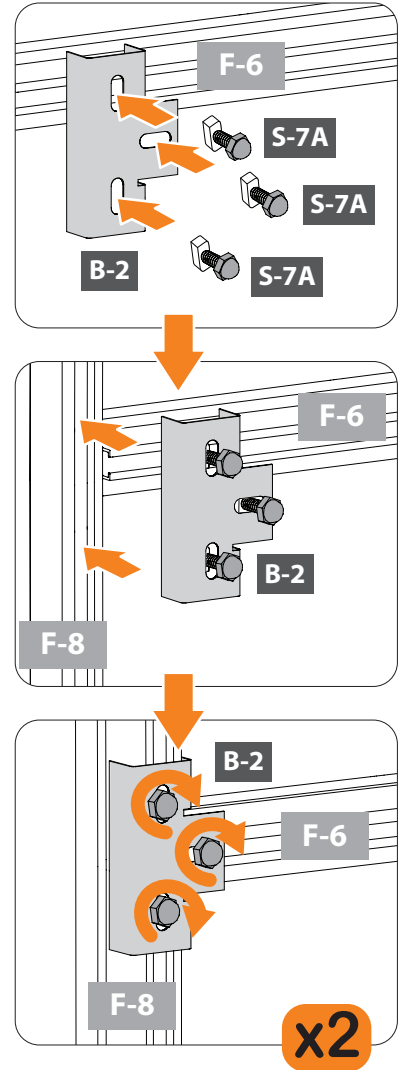

Connector	QTY	Profile	QTY	Connectors	QTY	
	S-11	4		F-10	2	
					B-2	2
					S-2C	6
					S-7	6

3.3D

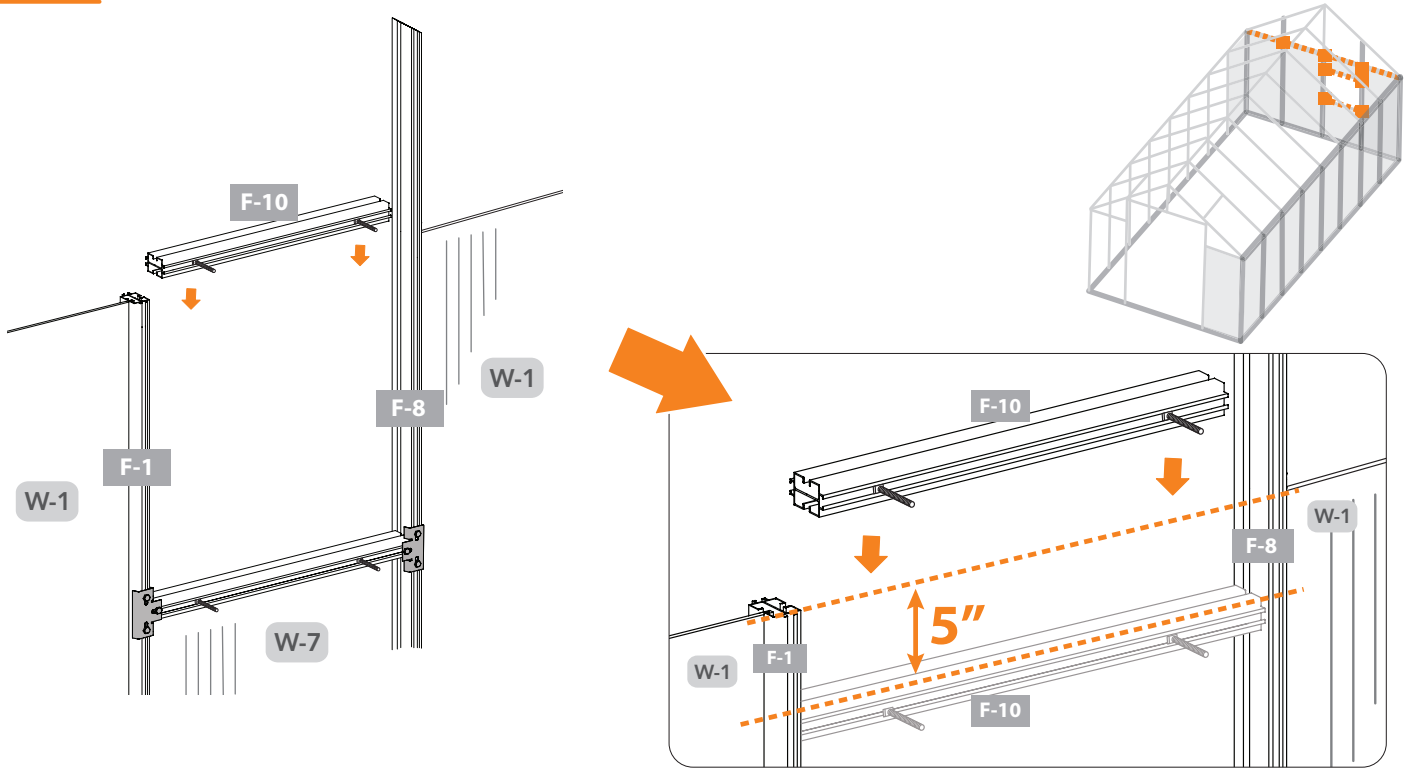

3.3E

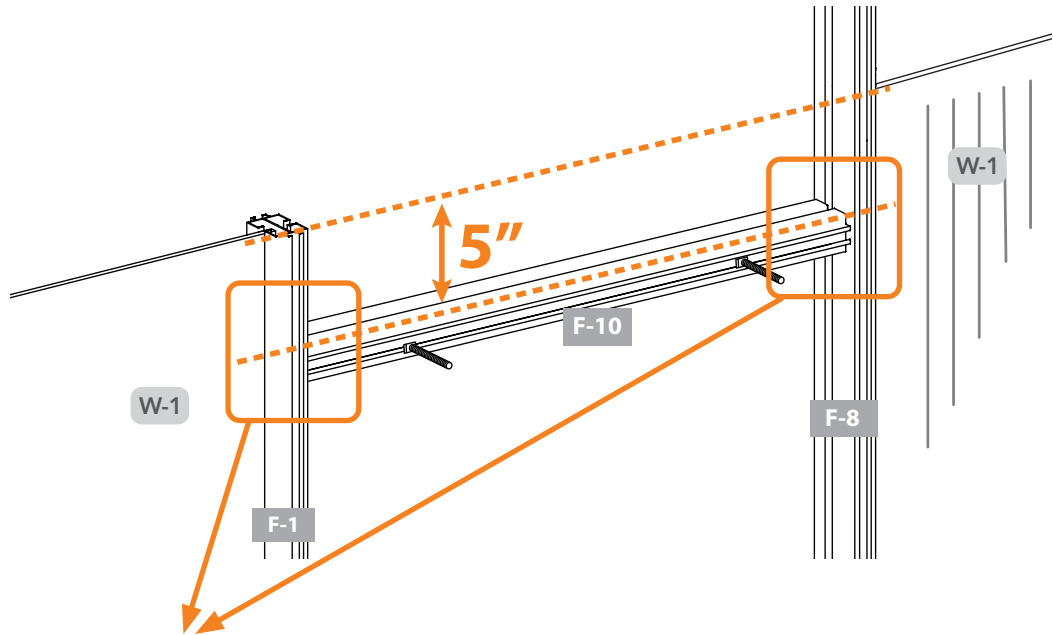

3.3F

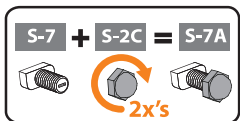
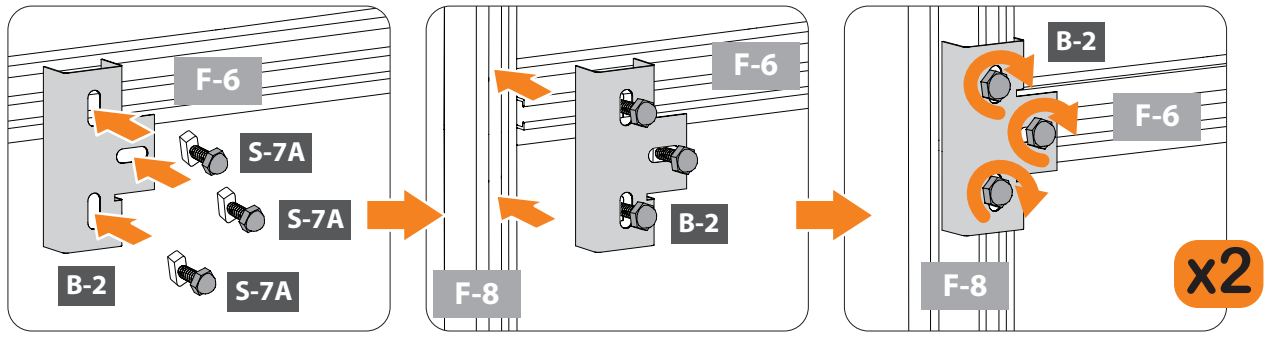



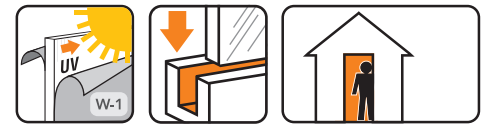
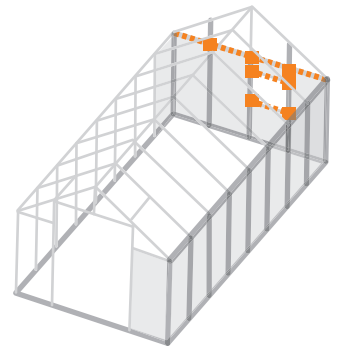
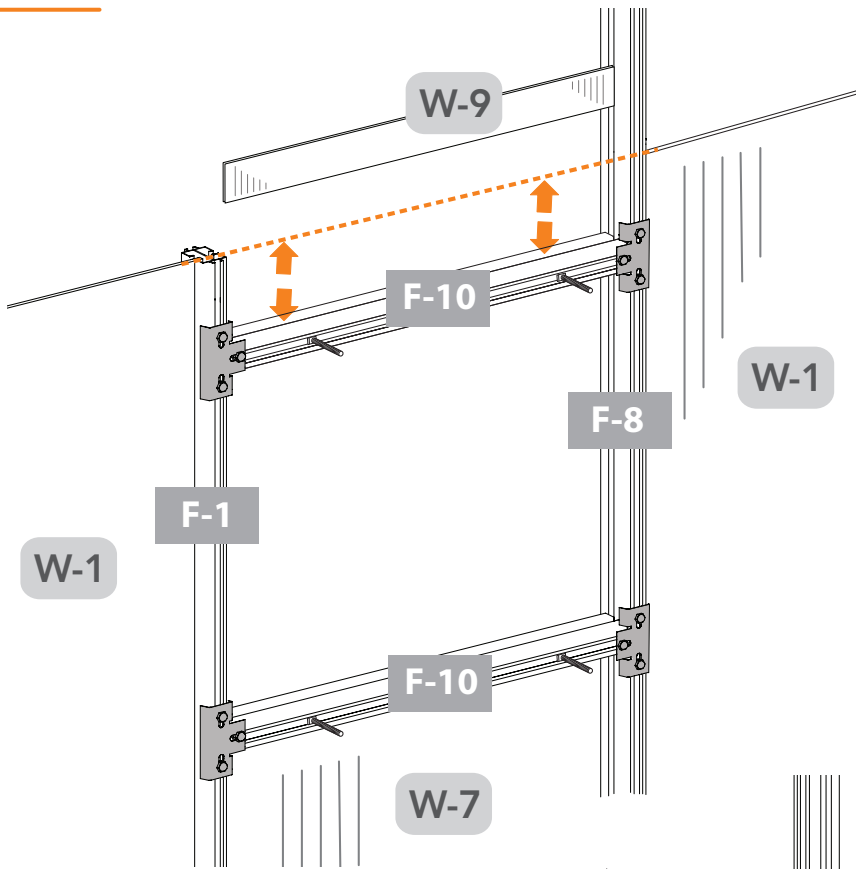

Connectors	QTY
B-2	2
S-2C	6
S-7	6

3.3G

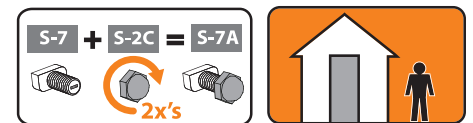
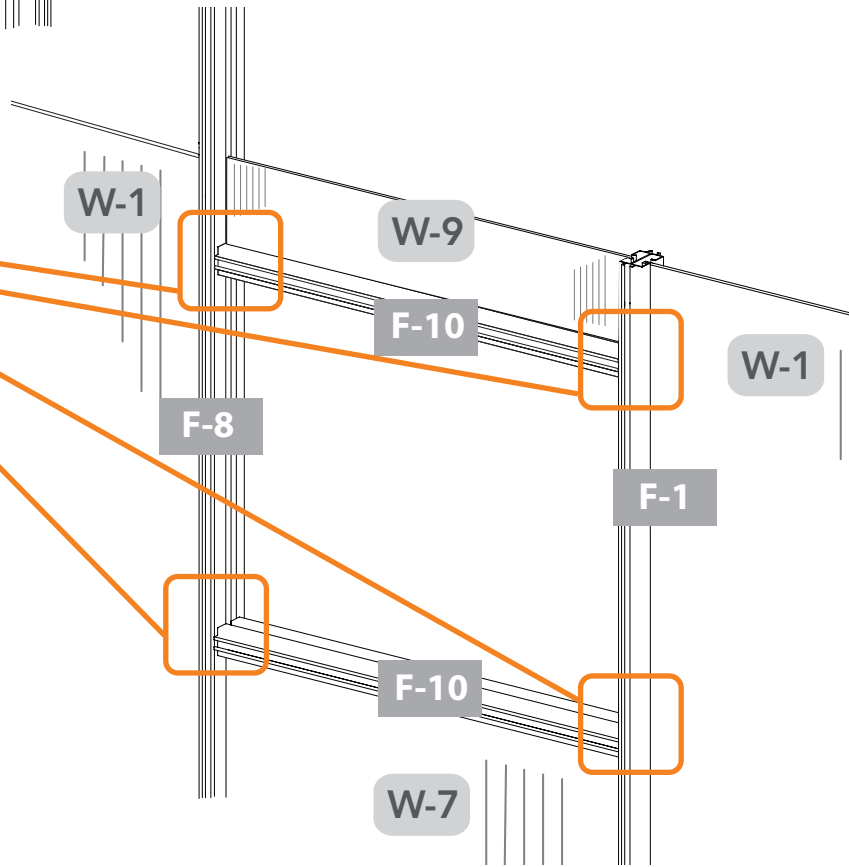
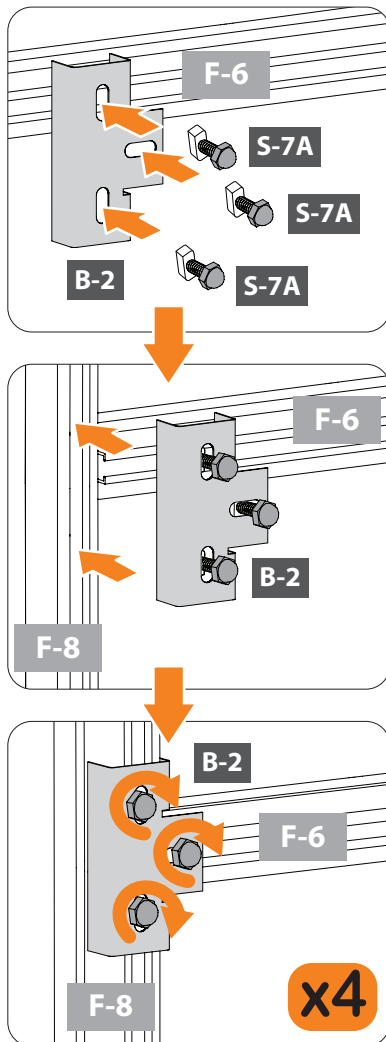

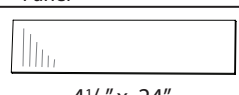
3.3H



Panel		Connectors		QTY	
Panel	QTY	Connectors			
 4 1/2" x 24"	W-9	1		B-2	4
				S-2C	12
				S-7	12

3.4A

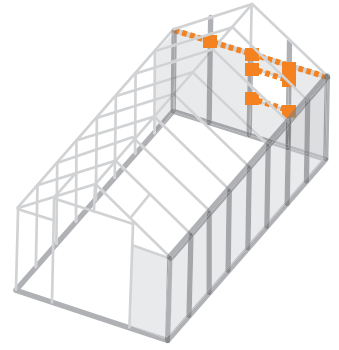
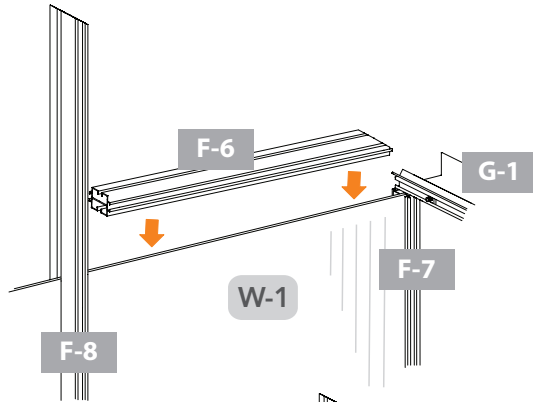

3.4B

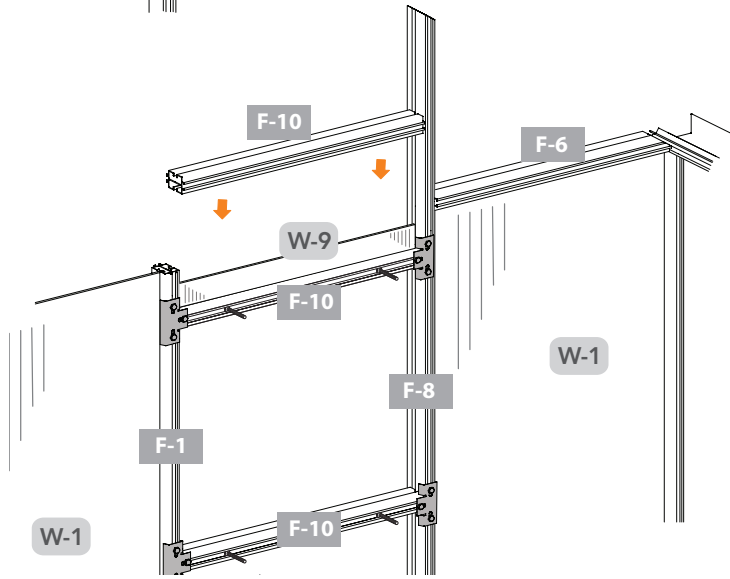

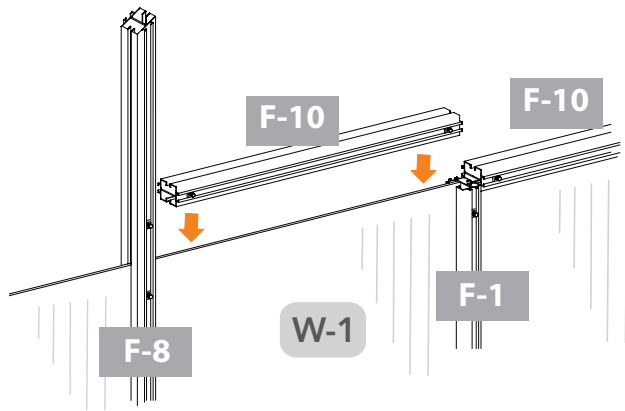

3.4C

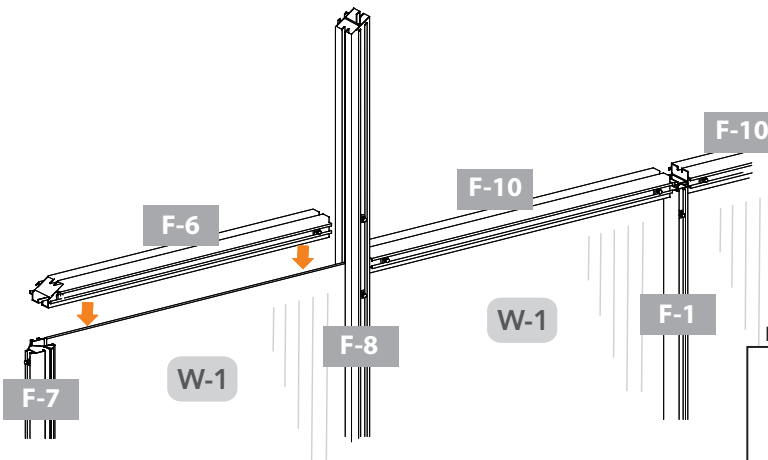

3.4D



Profile	QTY
 <div style="display: inline-block; text-align: center;"> <div style="border: 1px solid black; width: 60px; height: 10px; margin: 0 auto;"></div> <p>23"</p> </div>	F-6 2
 <div style="display: inline-block; text-align: center;"> <div style="border: 1px solid black; width: 60px; height: 10px; margin: 0 auto;"></div> <p>23"</p> </div>	F-10 2

3.5A

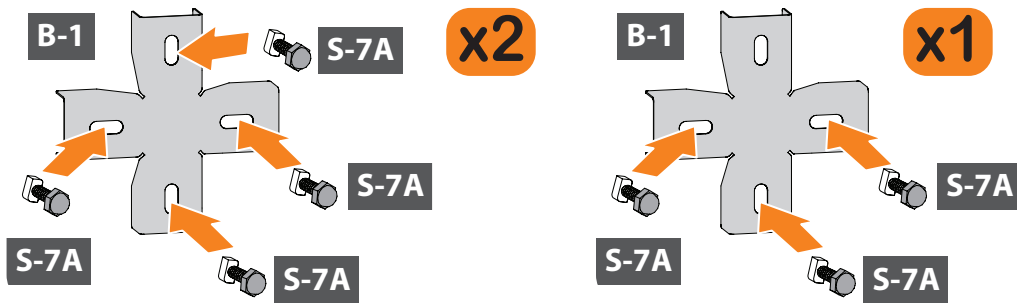

3.5B

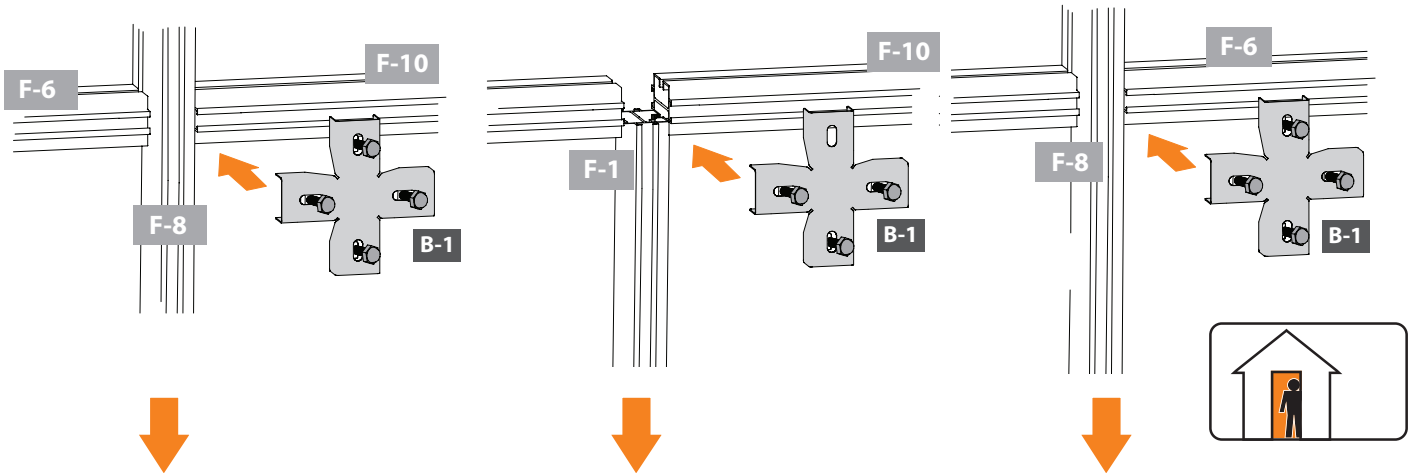

3.5C

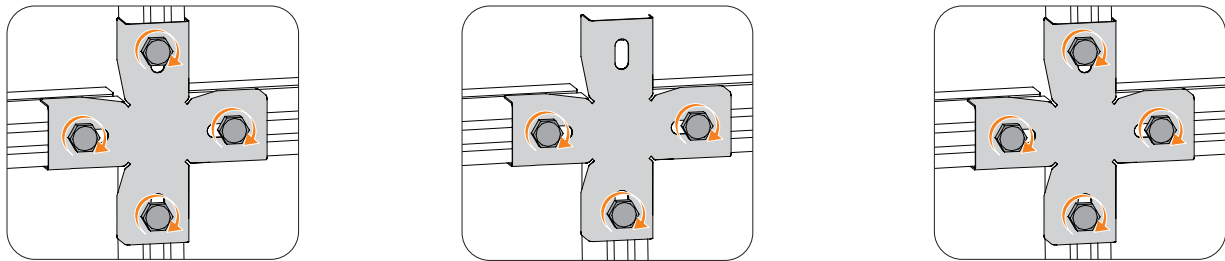

3.6

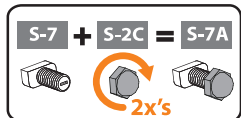
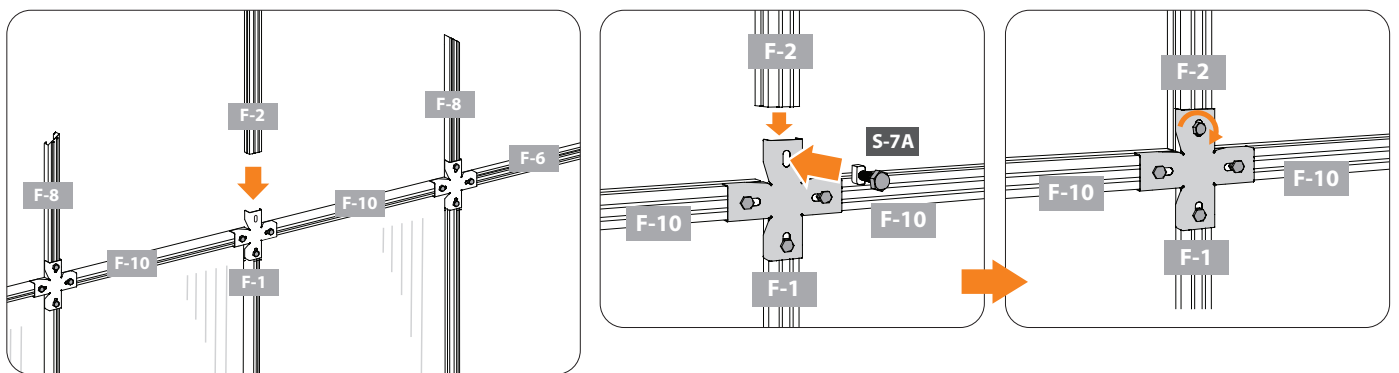

Profile	QTY	Connector	QTY
	F-2		12
			3
			12

Assemble Left Wall

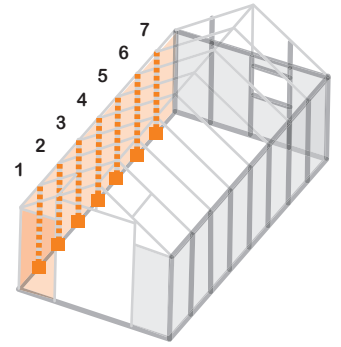
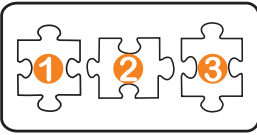

4.1A

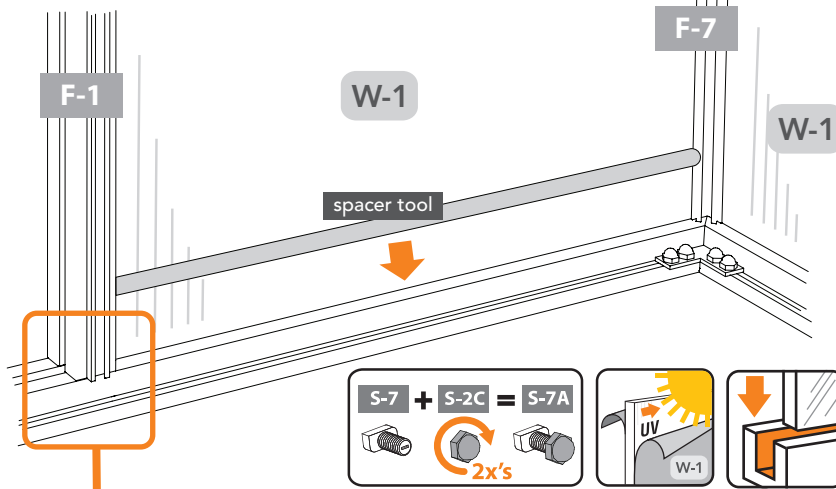

4.1B

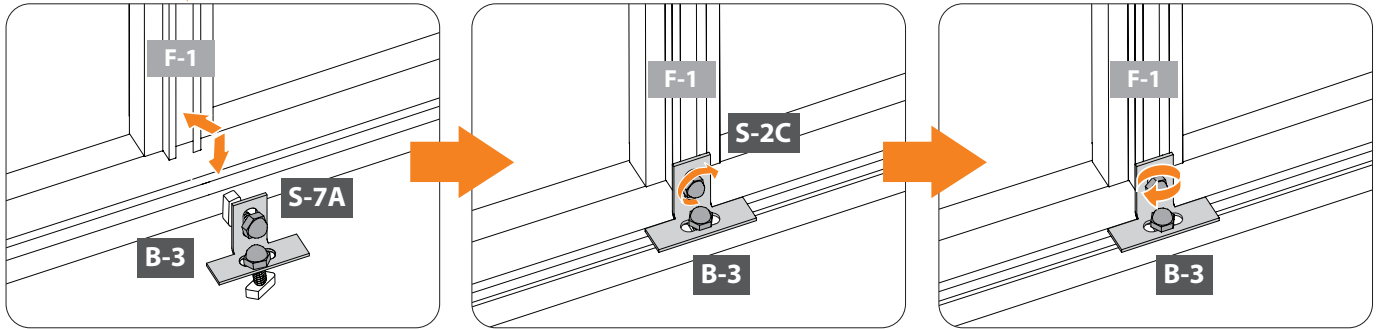

(4.1A - 4.1B) x 7



4.1C

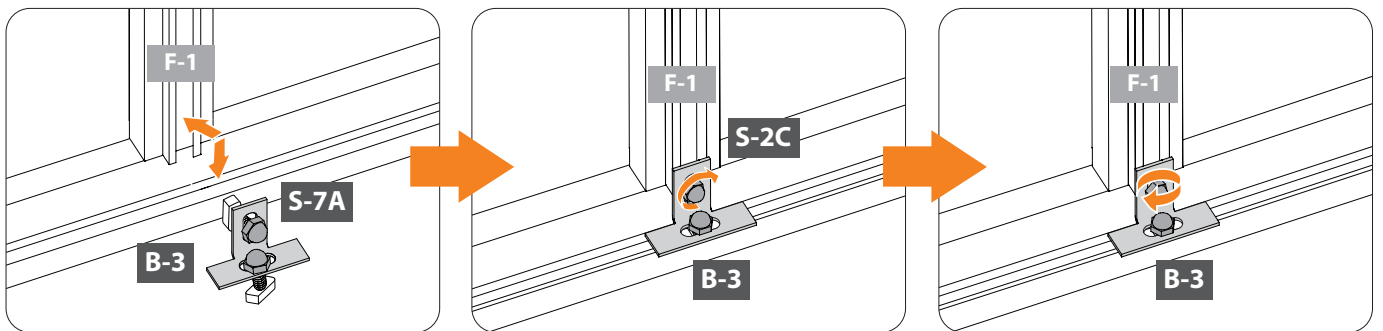

x7



Panel	QTY	Profile	QTY	Connector	QTY						
	7		7		<table border="1"> <tr> <td>B-3</td> <td>14</td> </tr> <tr> <td>S-2C</td> <td>28</td> </tr> <tr> <td>S-7</td> <td>28</td> </tr> </table>	B-3	14	S-2C	28	S-7	28
B-3	14										
S-2C	28										
S-7	28										

4.2A

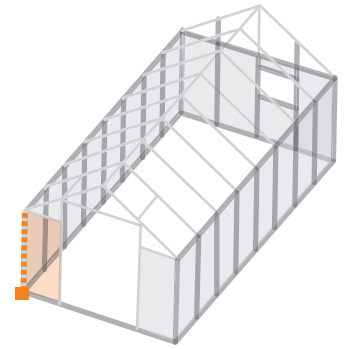
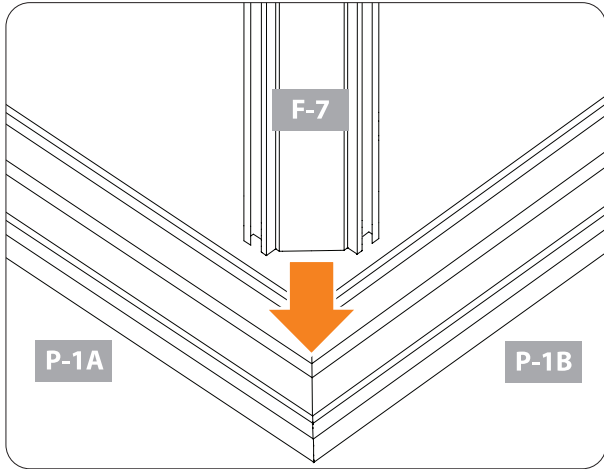

4.2B

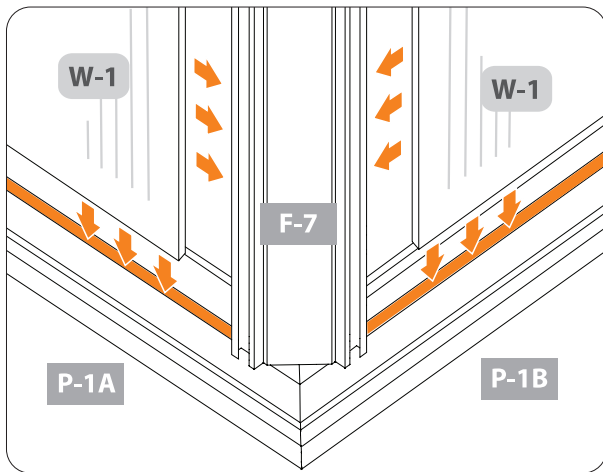

4.2C

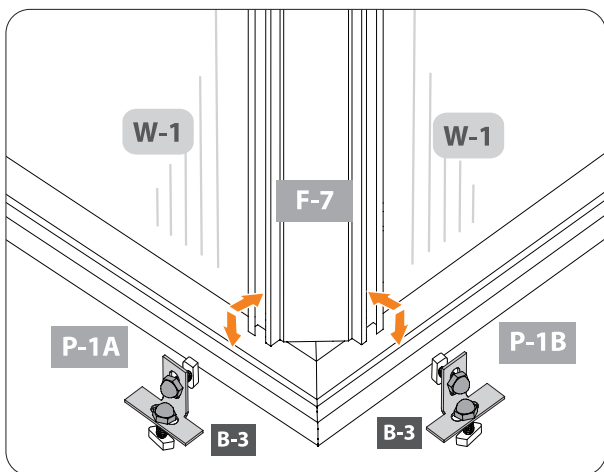



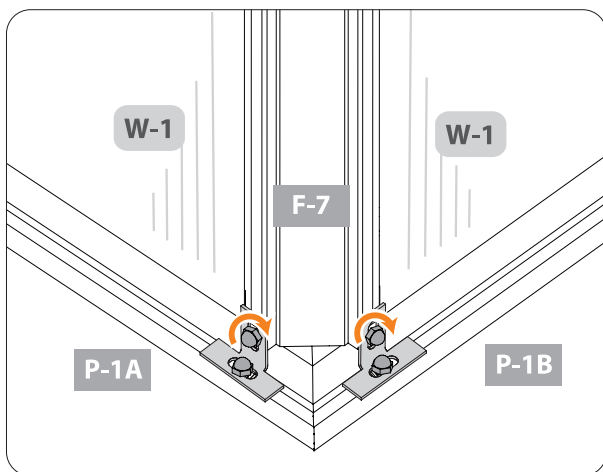

4.2D

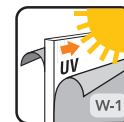
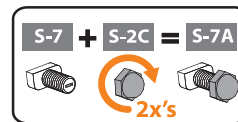
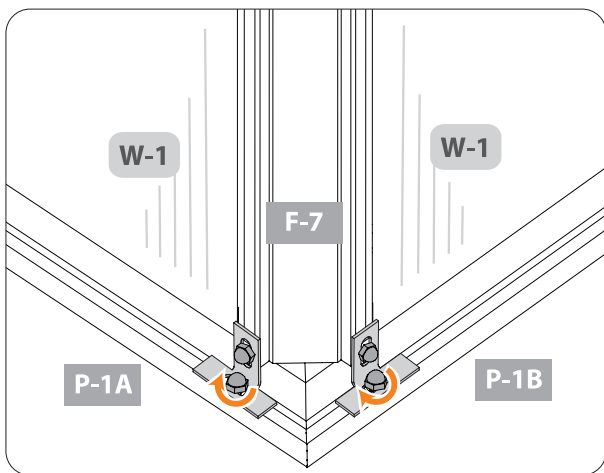

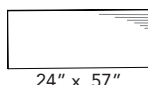
4.2E

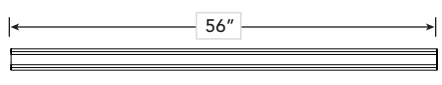

Panel	QTY	Profile	QTY	Connectors	QTY	
 24" x 57"	W-1	1			B-3	2
			 56"		S-2C	4
			F-7		S-7	4

Install Pre-Assembled Gutter

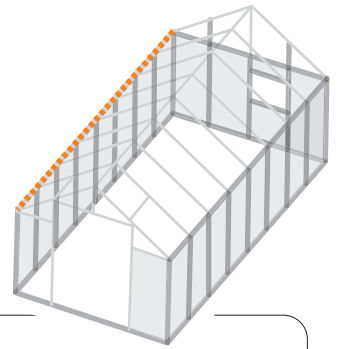
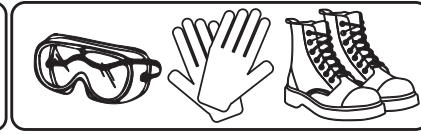
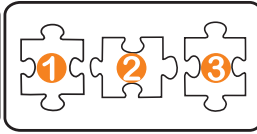

(2.4A - 2.5I) x 1 (see page 29)

4.5A

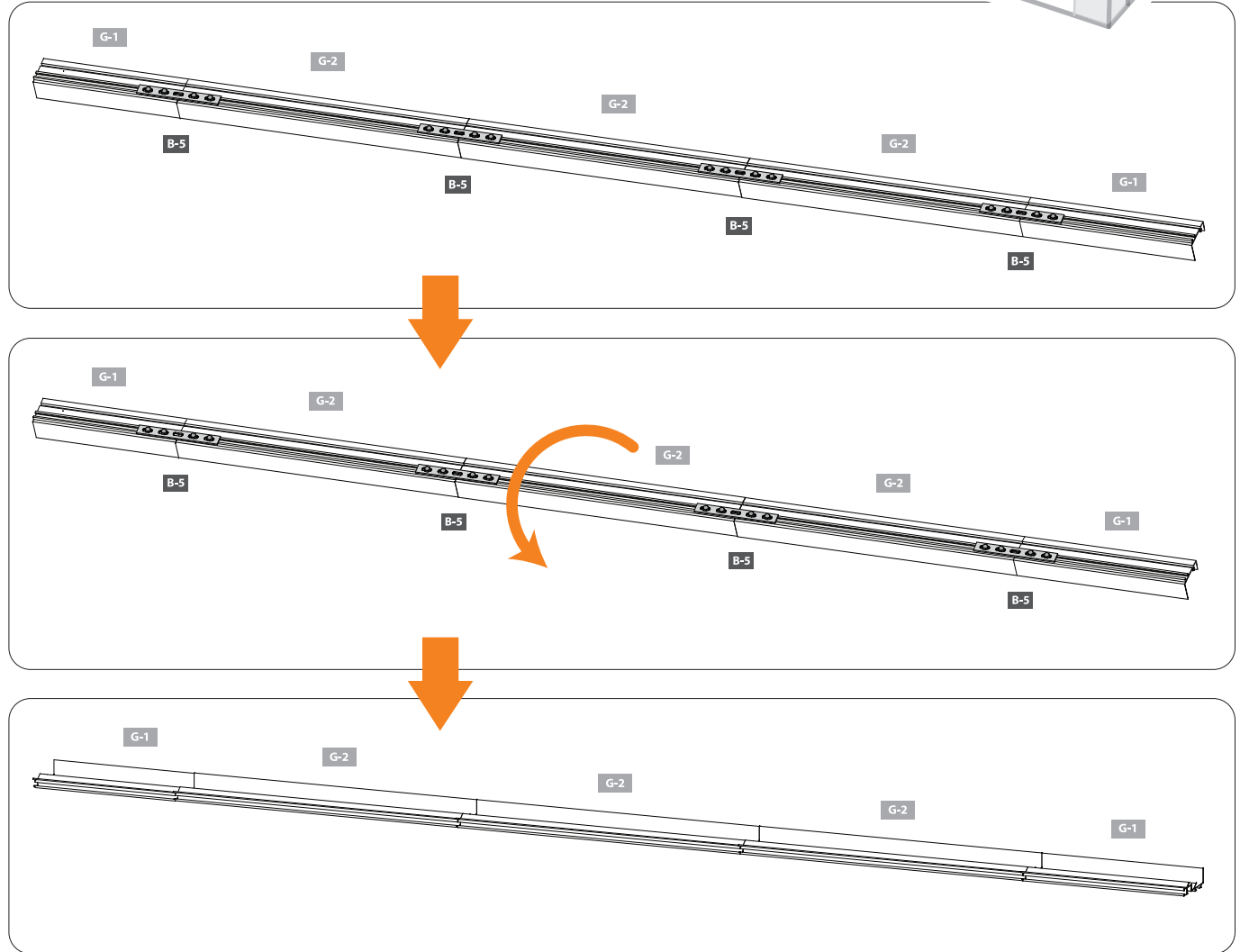

4.5B

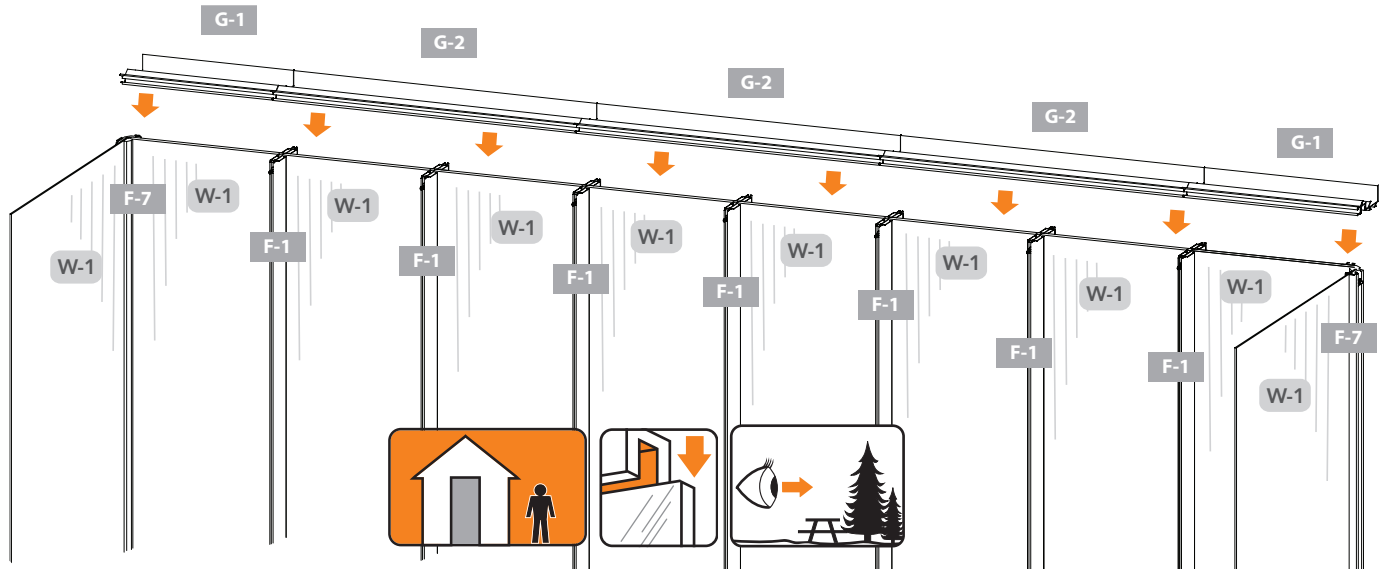

4.5C

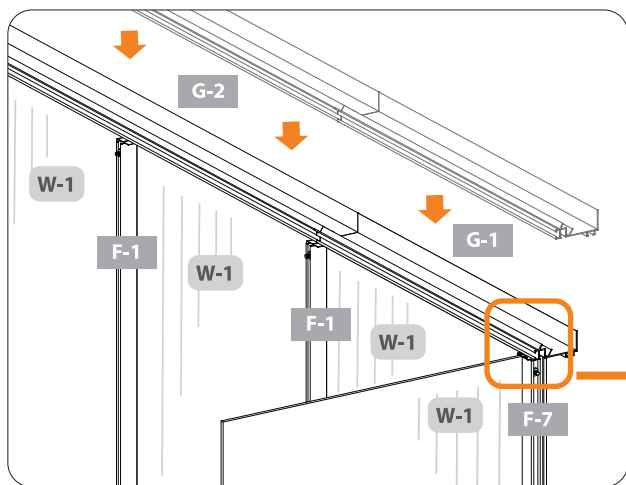

Scan This QR Code!
To be taken to helpful Pro-tips, techniques, and assembly videos!
Reference #05

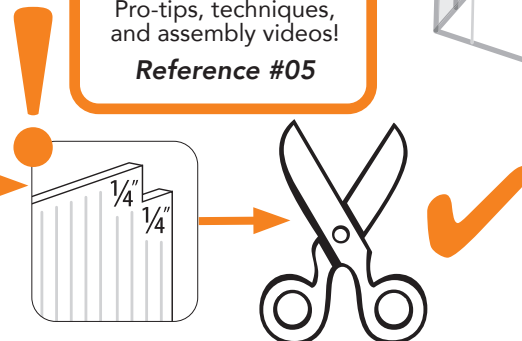
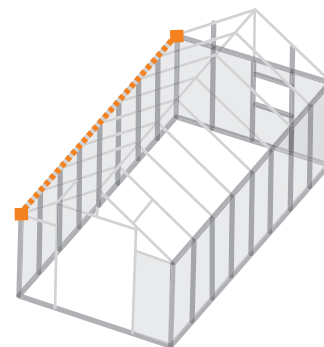

1 REAR

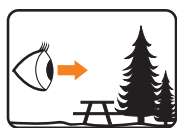

FRONT 2

4.5D

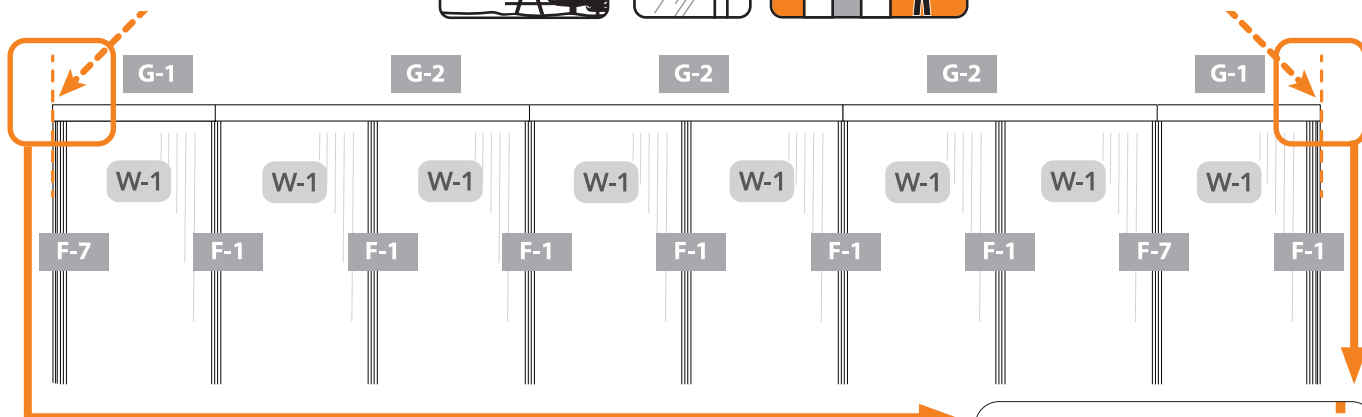

1 & 2

NOTE: At front and back, edge of G-1 gutter profile lines up flush with edge of F-7 corner profile.
REMARQUE: À l'avant et à l'arrière, le bord du profilé de gouttière G-1 est aligné avec le bord du profilé d'angle F-7.
NOTA: En la parte delantera y trasera, el borde del perfil de canalón G-1 se alinea al ras con el borde del perfil de esquina F-7.



4.5E

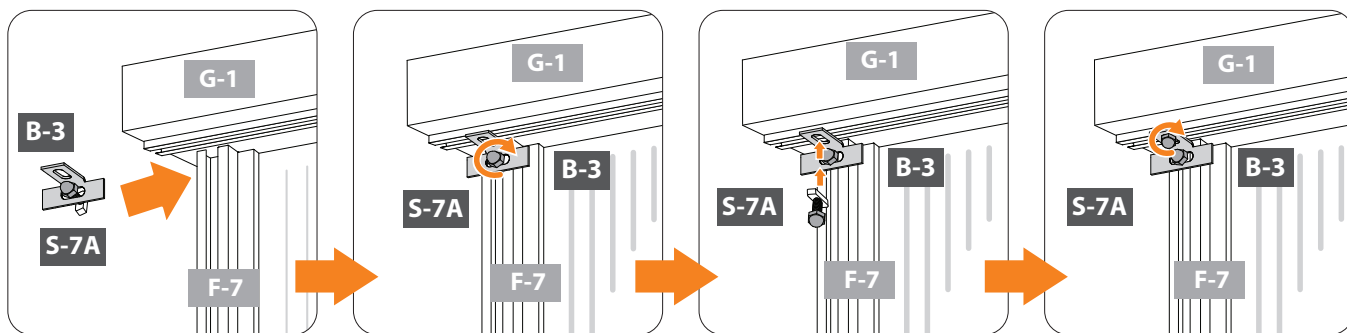

Connectors		QTY	Connectors		QTY	Connectors		QTY
	B-3	2		S-2C	4		S-7	4

3 5 7 9 : (4.7A - 4.7F)

4 6 8 : (4.6A - 4.6D)

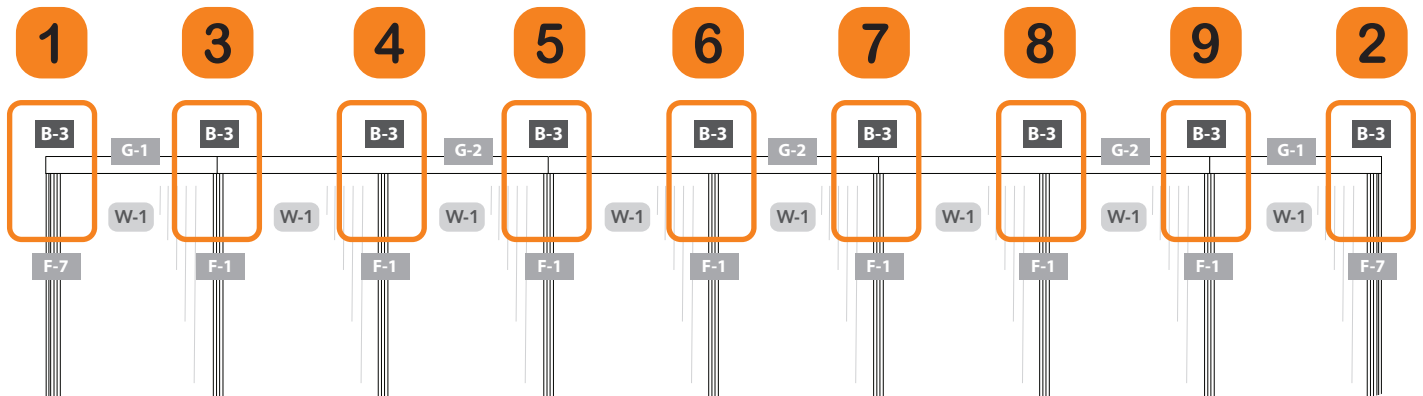
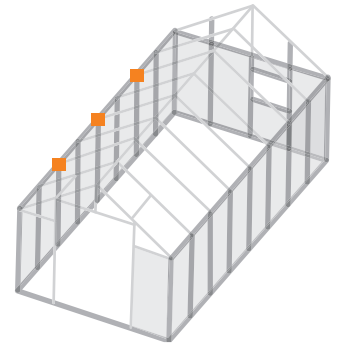
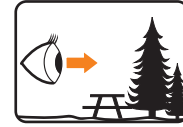

4.6A

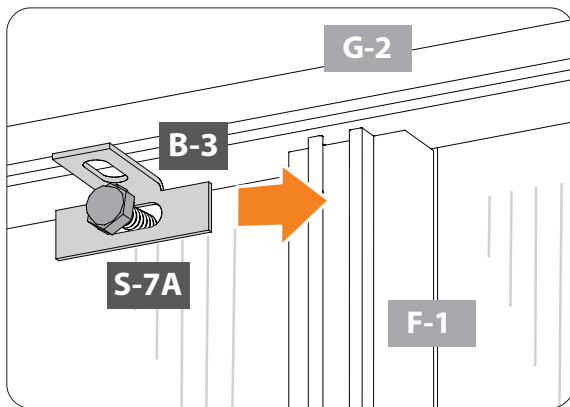

4.6B

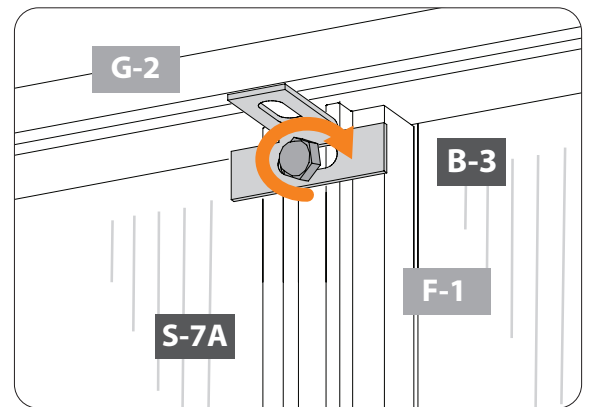

4.6C

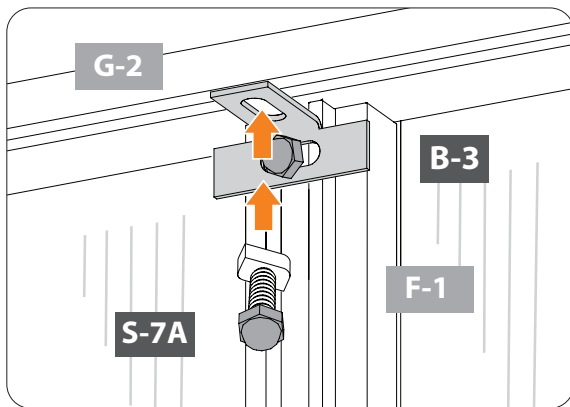

4.6D

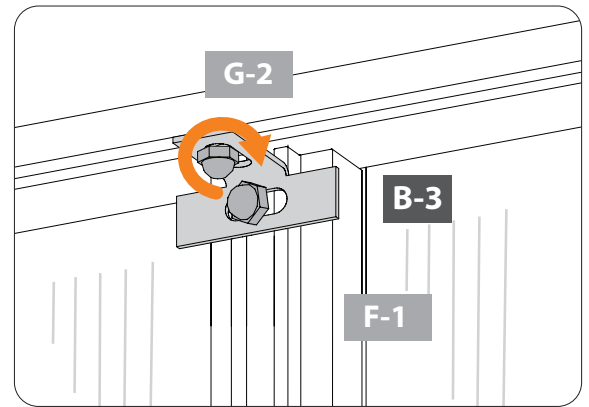

4.6E **(4.6A - 4.6D) x 3**

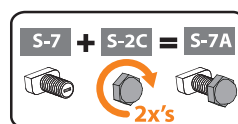

Connectors	QTY
B-3	3
S-2C	6
S-7	6

4.7A

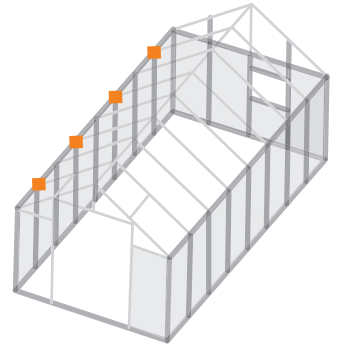
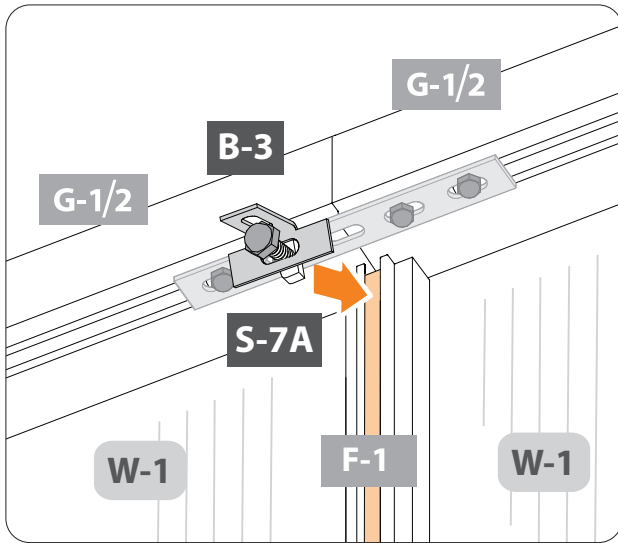

4.7B

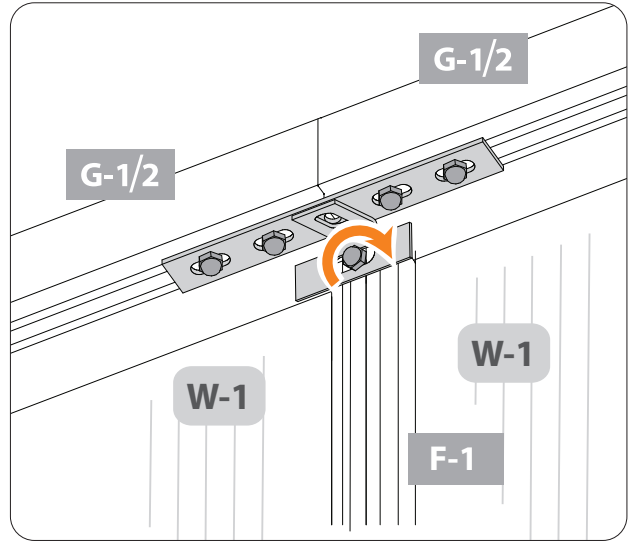

4.7C

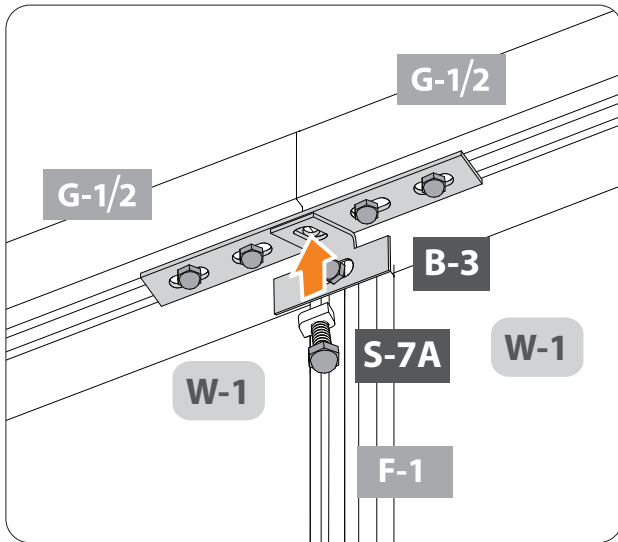

4.7D

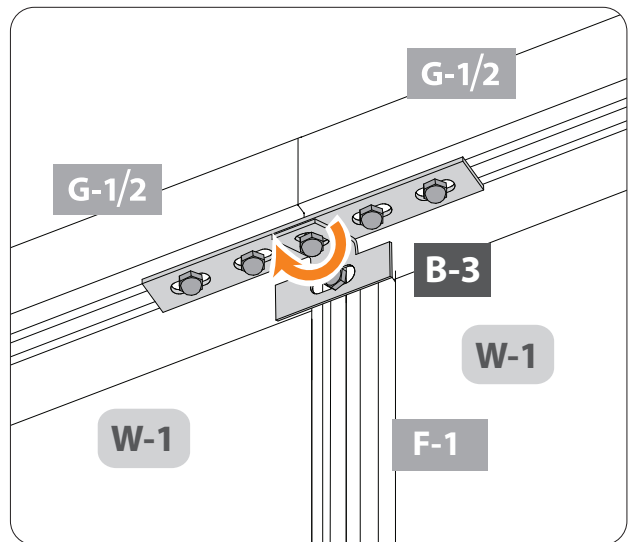

4.7E (4.7A - 4.7D) x 4

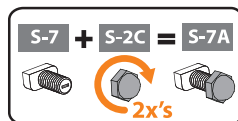

Connectors		QTY
	B-3	4
	S-2C	8
	S-7	8

Assemble Front Wall and Gable

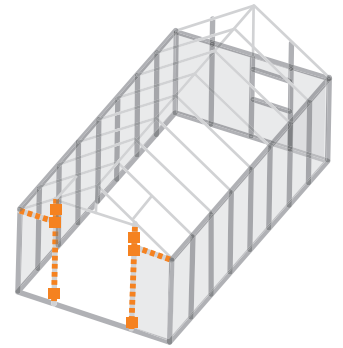
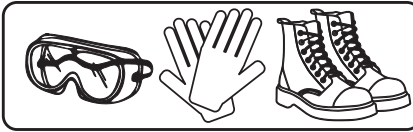
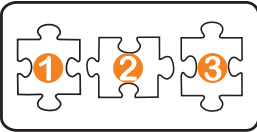

5.1A

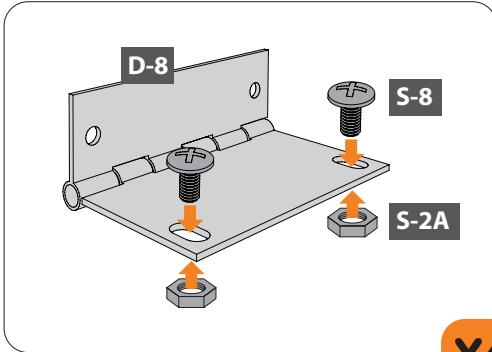

x4

5.1B

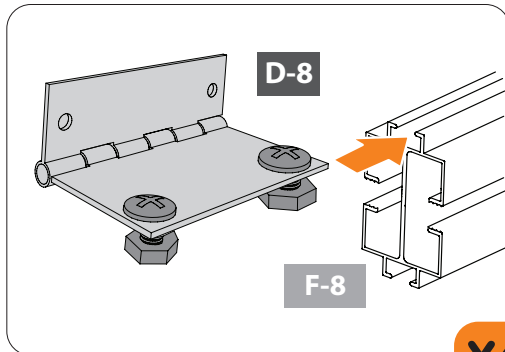

x4

5.1C

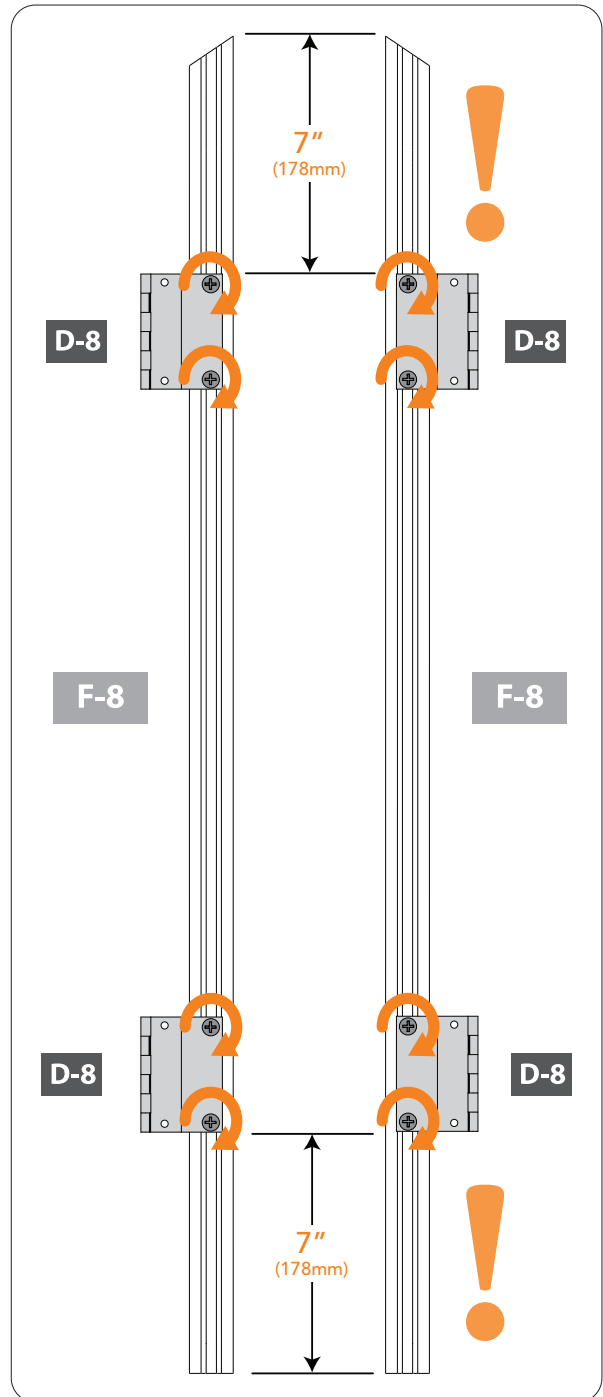

Profile	QTY	Connectors	QTY
	F-8		D-8 4 S-8A 8 S-2A 8

5.1D

see (5.1E) ←

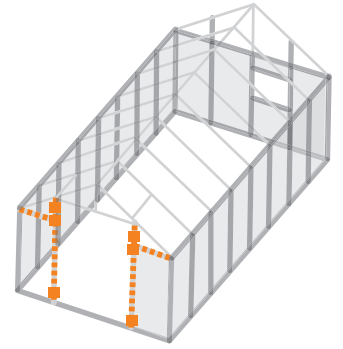
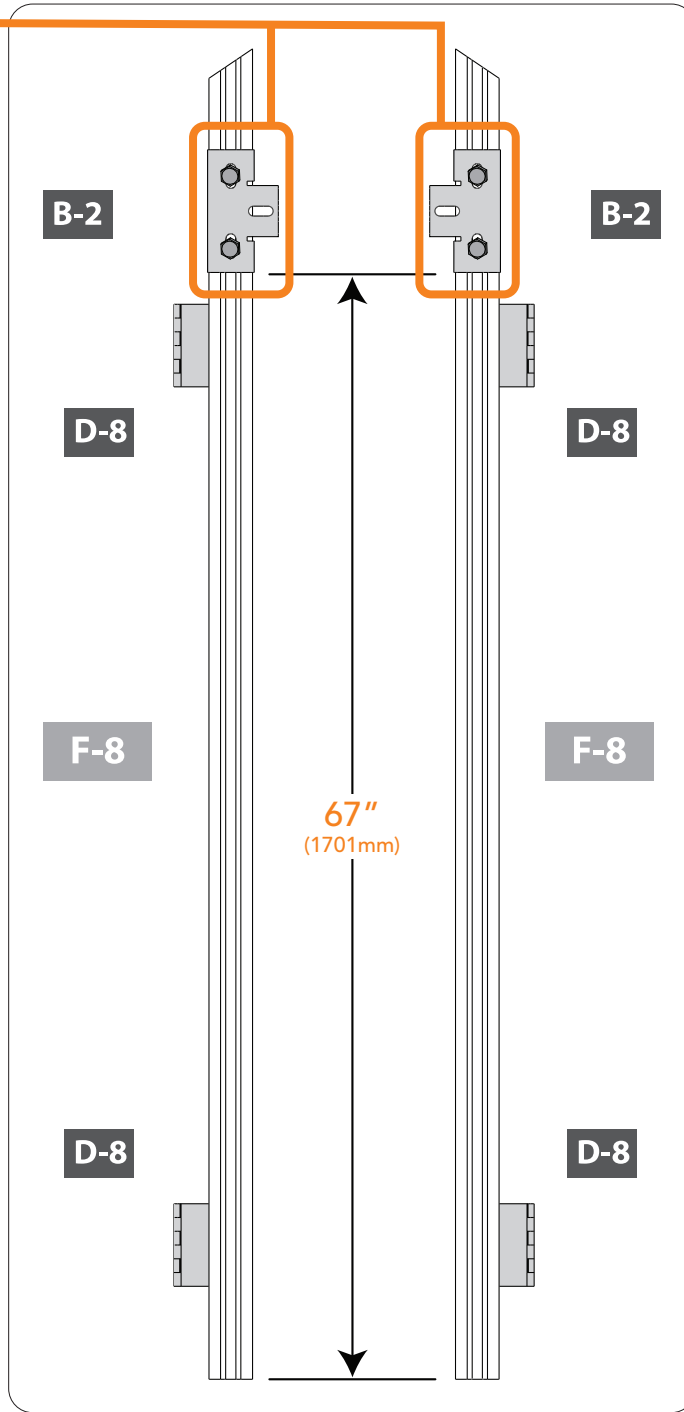
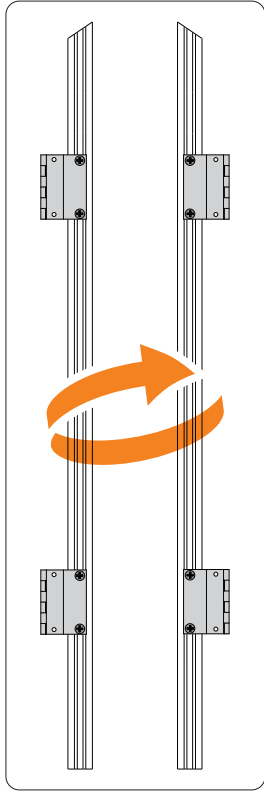

NOTE: Height of **B-2** may require adjustment, 67"-68" depending on your specific situation. *See 5.5B-5.5C.*

REMARQUE: Hauteur de **B-2** peut nécessiter un ajustement, 67"-68" selon votre situation spécifique. *Voir 5.5B-5.5C.*

NOTA: Altura de **B-2** puede requerir un ajuste, 67"-68" dependiendo de su situación específica. *Consulte 5.5B-5.5C.*



5.1E

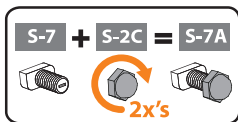
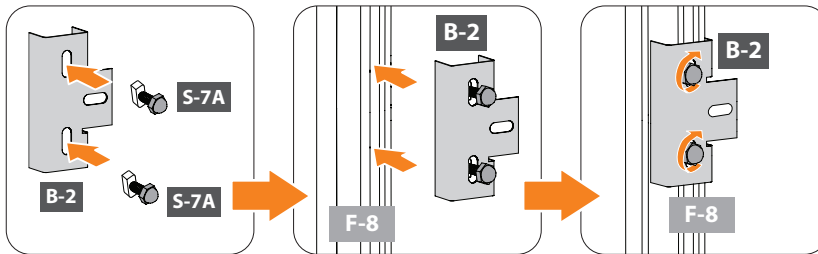



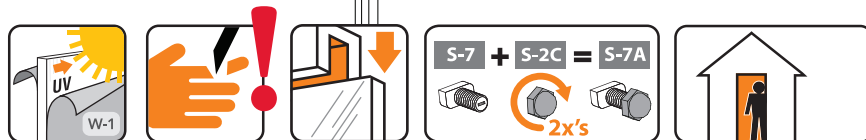
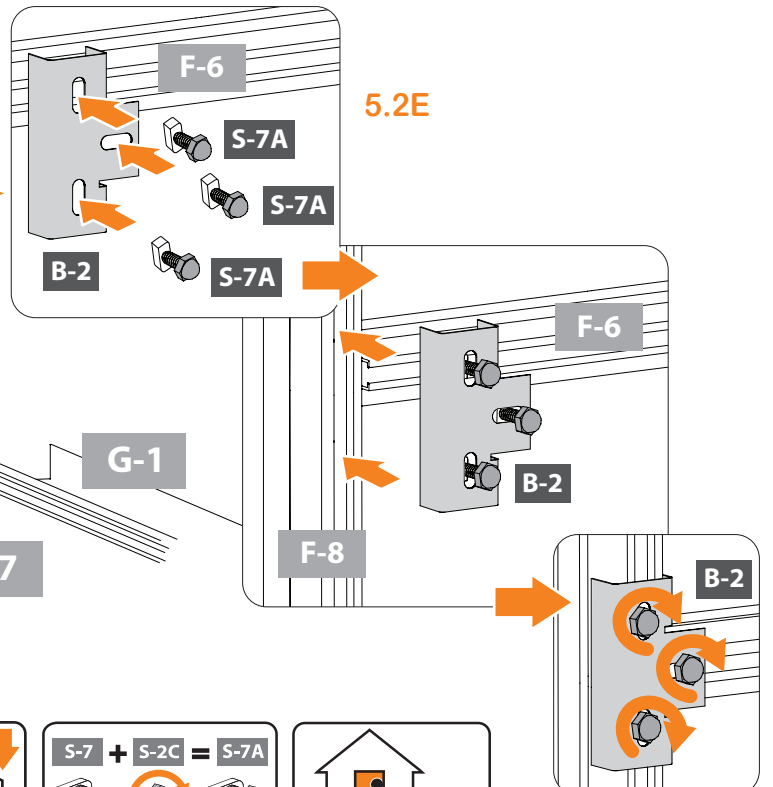
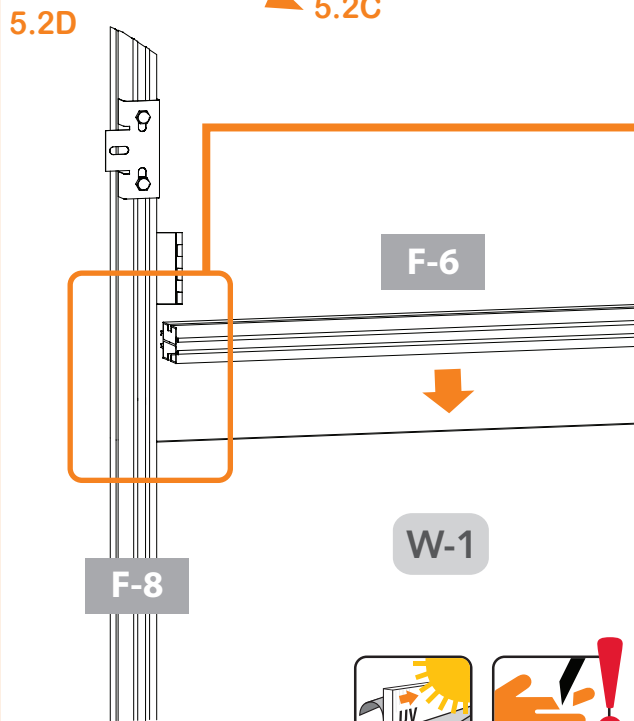
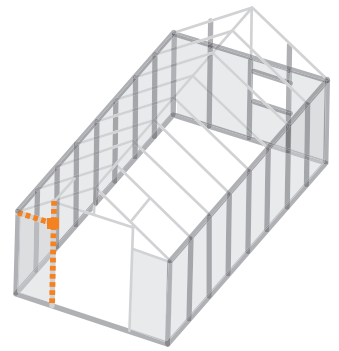
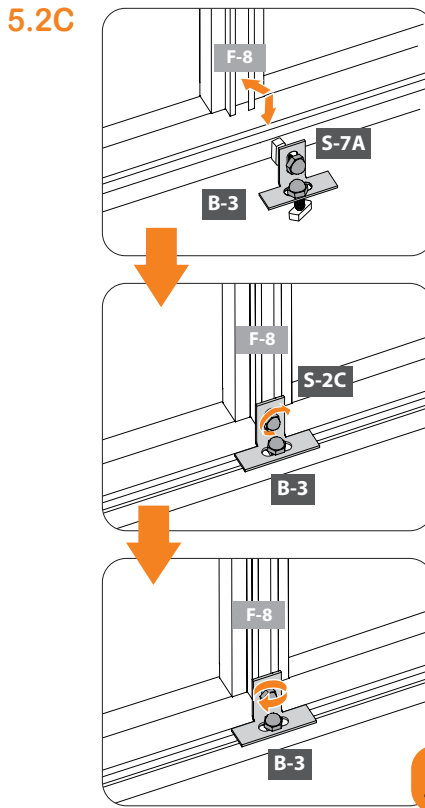
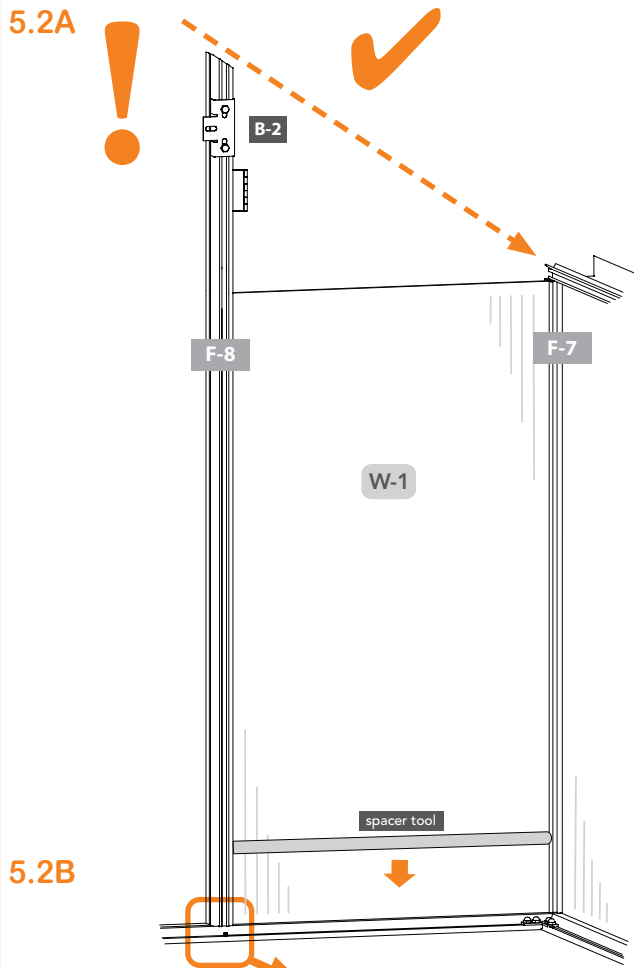

x2

Connectors		QTY
	B-2	2
	S-2C	4
	S-7	4

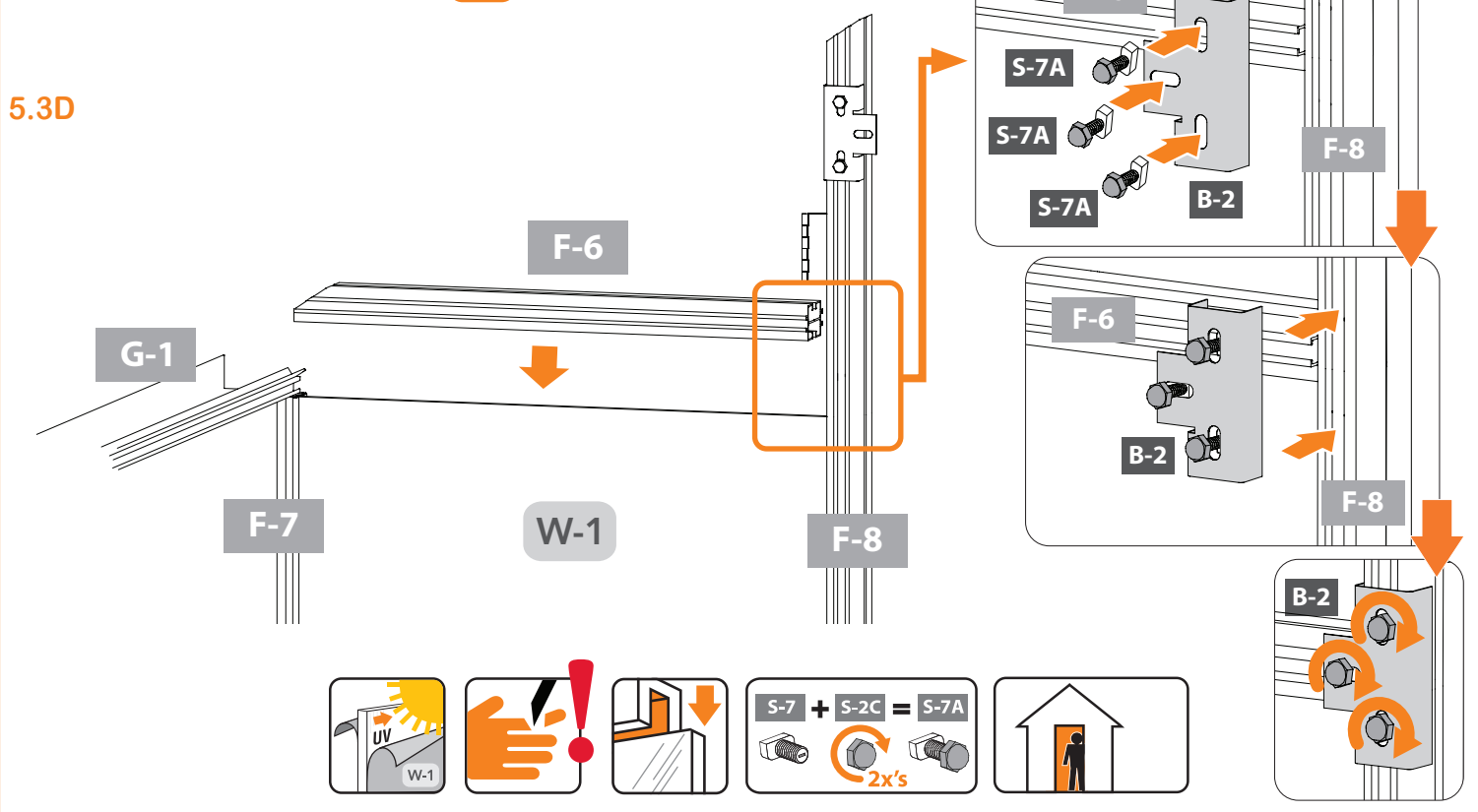
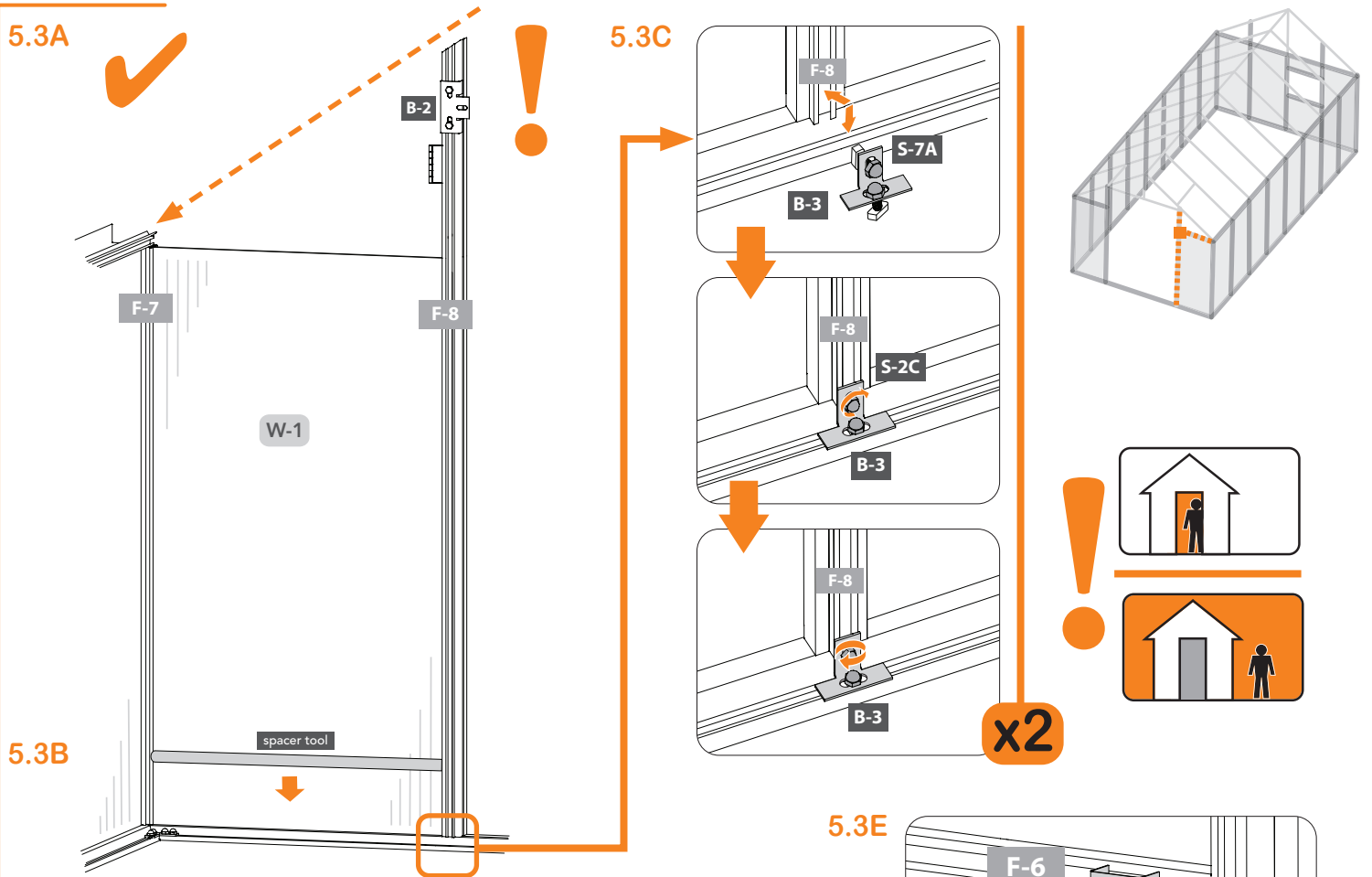

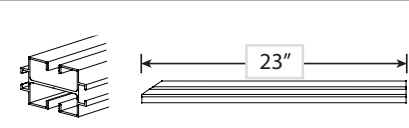
Profile	QTY	Connectors	QTY	Connector	QTY
	1		1		2
			7		7



Profile	QTY	Connectors	QTY	Connector	QTY
	1	 	1 7	 	2 7

5.4A

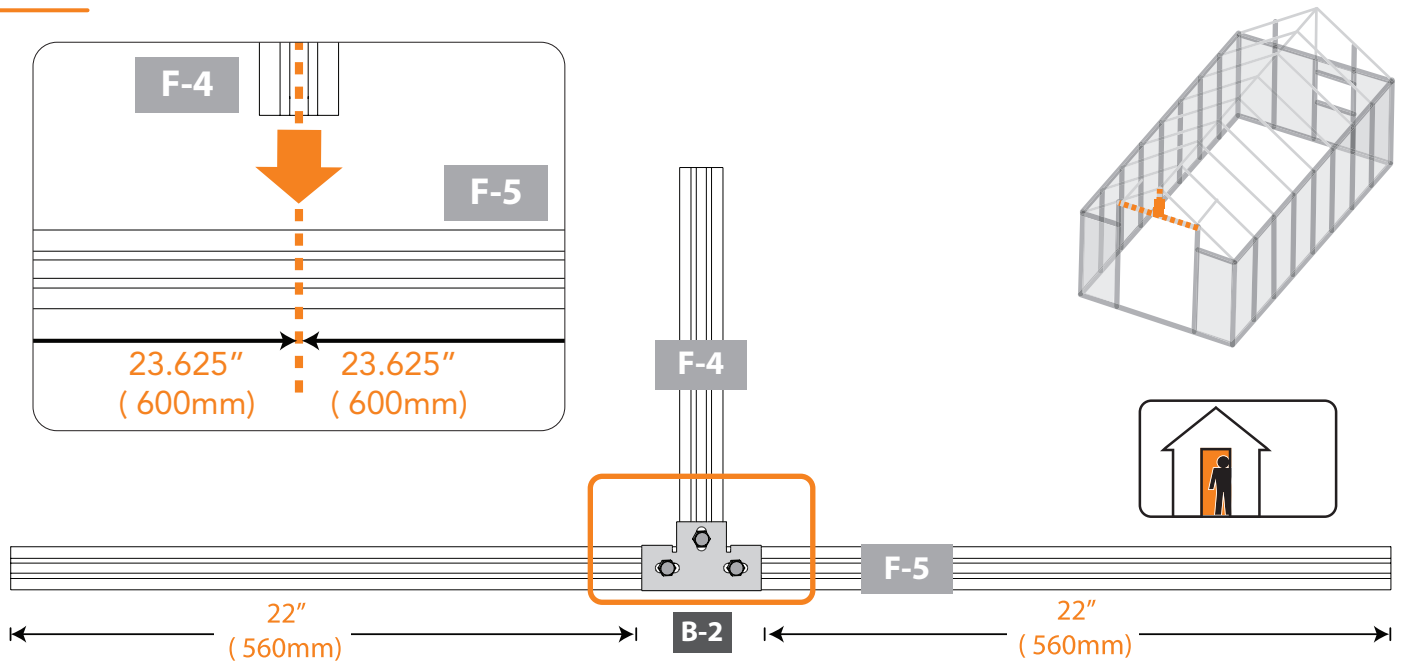

5.4B

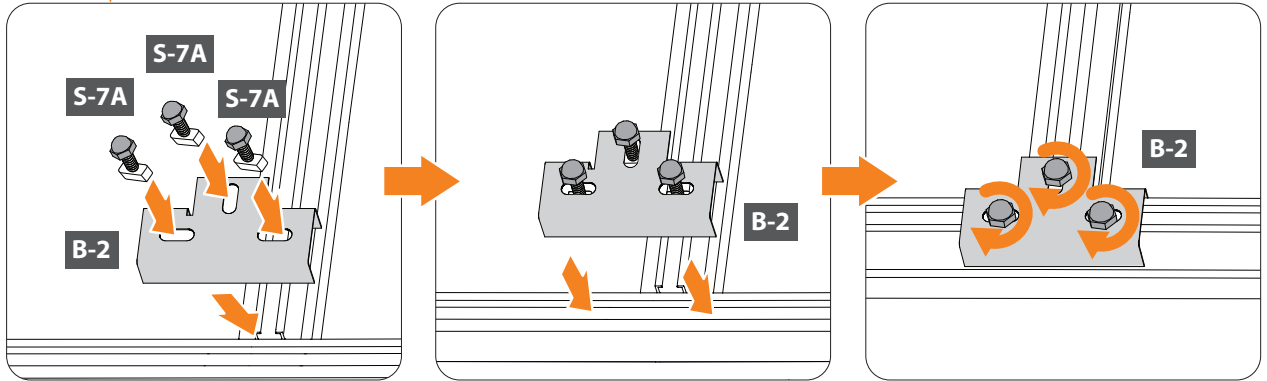

5.4C

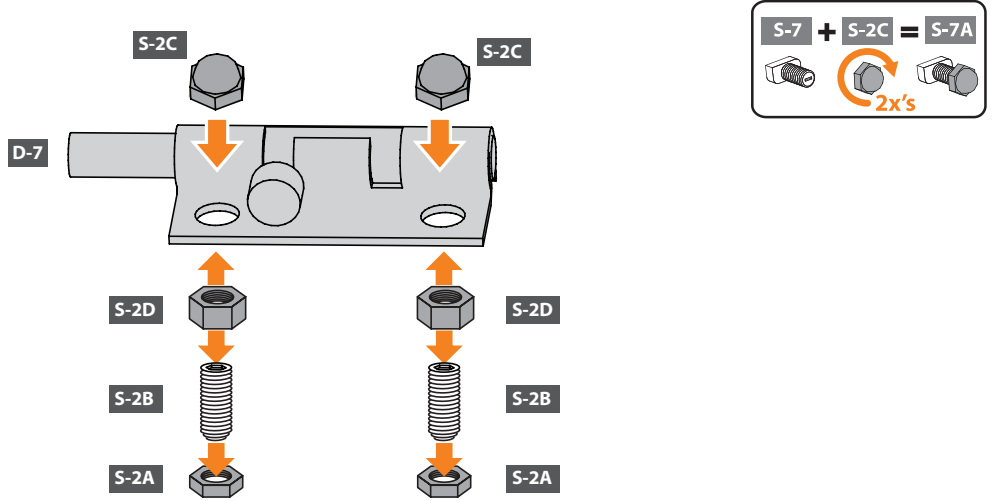

Profile	QTY	Connectors	QTY	CONNECTORS	QTY
	1		1		2
			1		2
			3		5
					2

5.4D

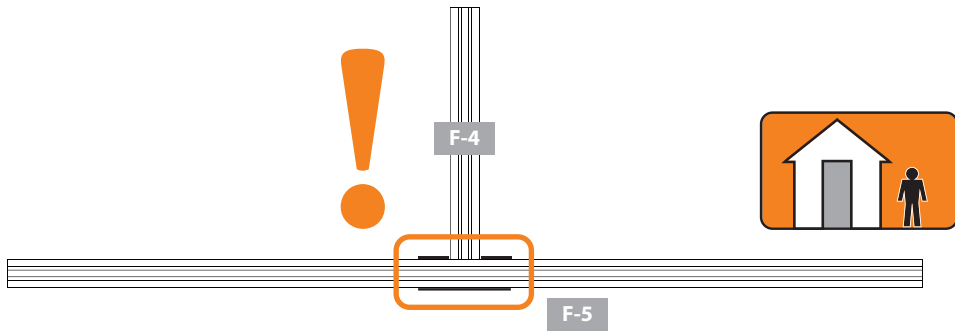
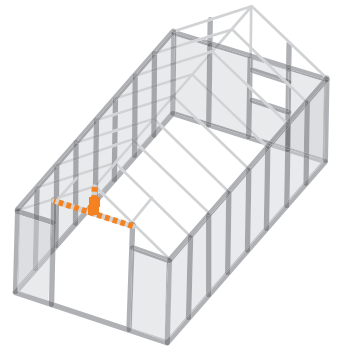
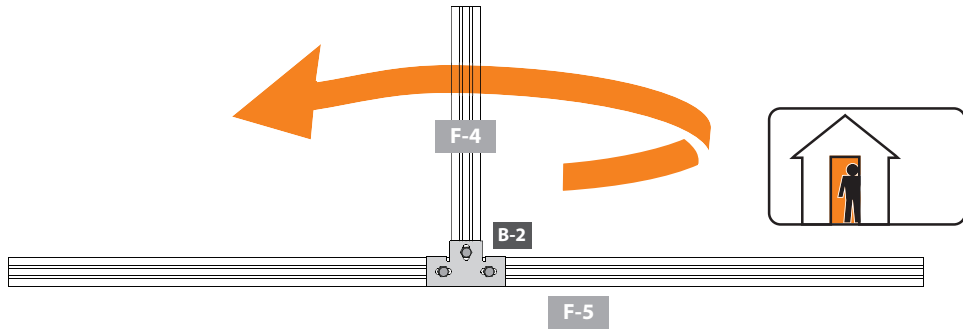

5.4E

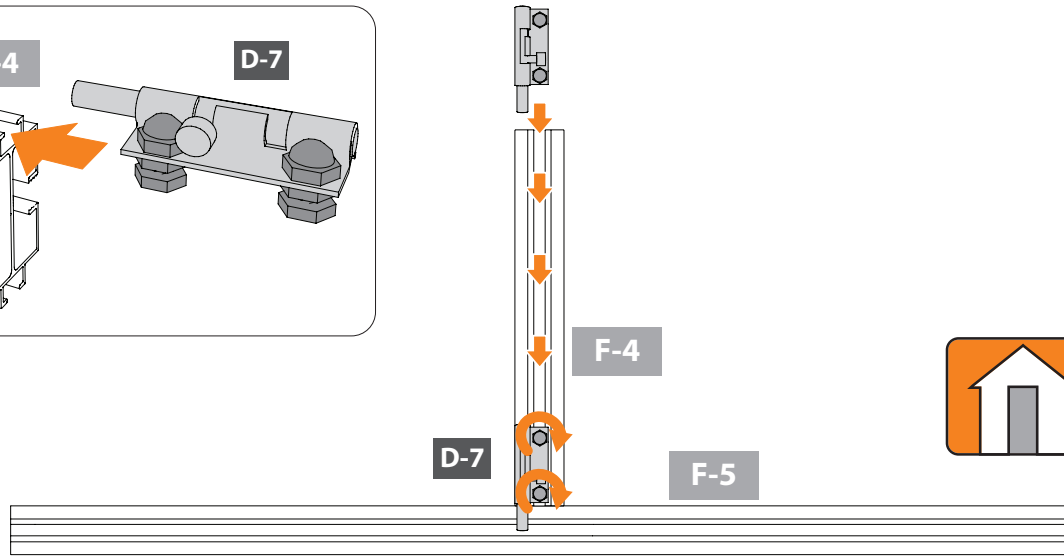
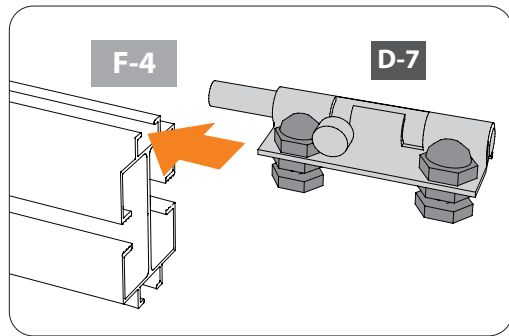

5.4F

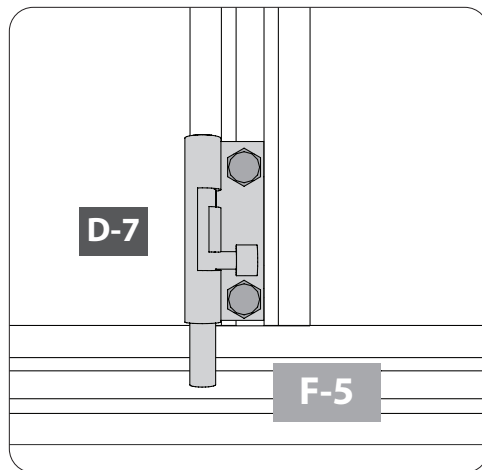

5.5A

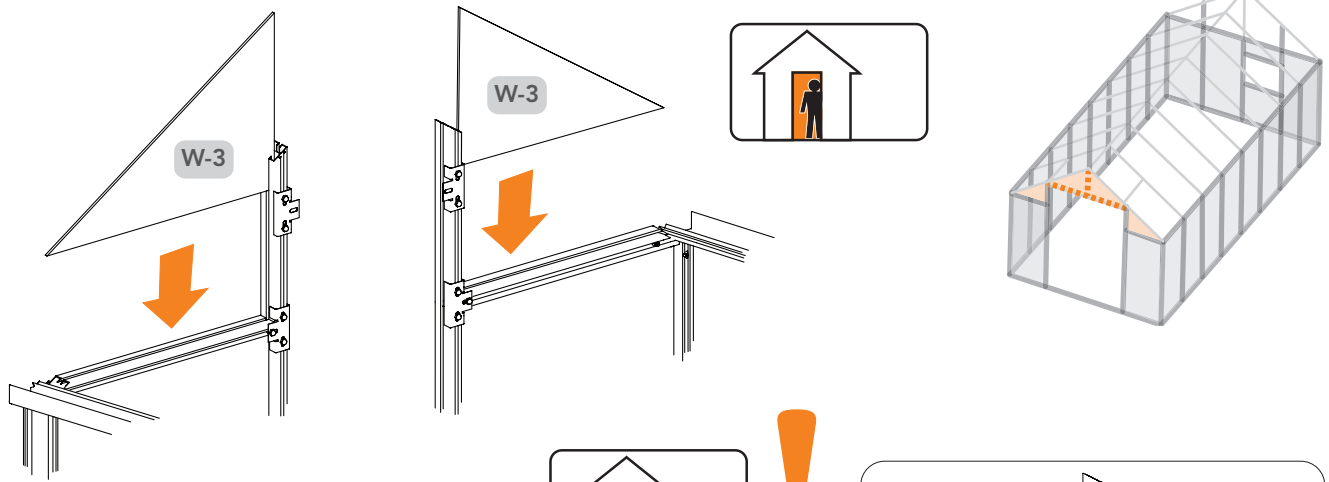

5.5B

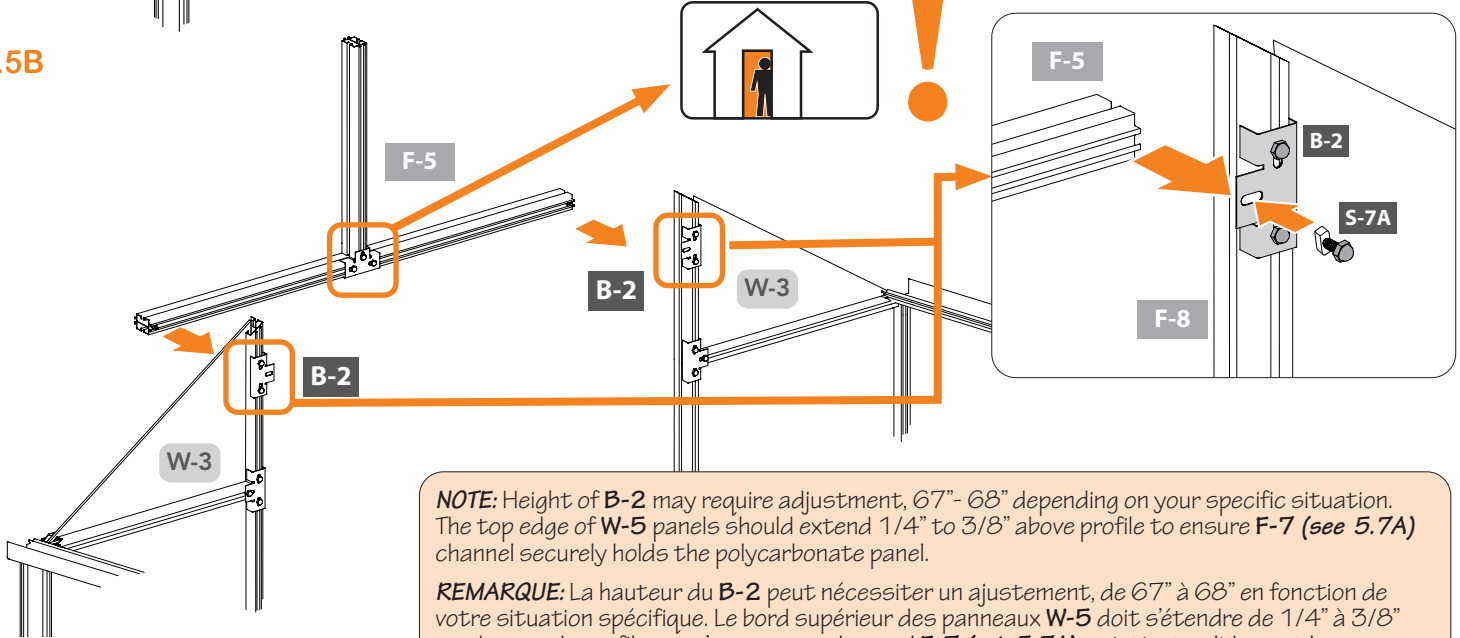



NOTE: Height of **B-2** may require adjustment, 67" - 68" depending on your specific situation. The top edge of **W-5** panels should extend 1/4" to 3/8" above profile to ensure **F-7** (see 5.7A) channel securely holds the polycarbonate panel.

REMARQUE: La hauteur du **B-2** peut nécessiter un ajustement, de 67" à 68" en fonction de votre situation spécifique. Le bord supérieur des panneaux **W-5** doit s'étendre de 1/4" à 3/8" au-dessus du profil pour s'assurer que le canal **F-7** (voir 5.7A) maintient solidement le panneau en polycarbonate.

NOTA: La altura de **B-2** puede requerir un ajuste, 67"- 68" dependiendo de su situación específica. El borde superior de los paneles **W-5** debe extenderse de 1/4" a 3/8" por encima del perfil para garantizar que el canal **F-7** (ver 5.7A) sujeta firmemente el panel de polycarbonato.

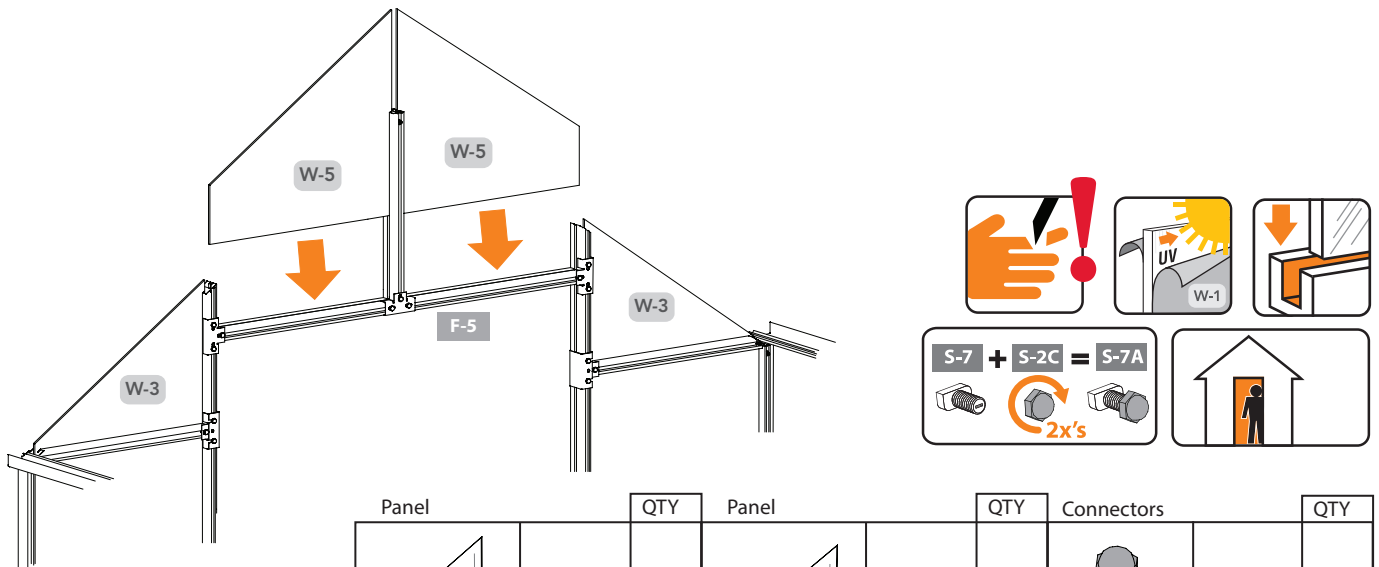
5.5C

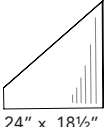
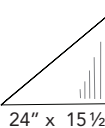

Panel	QTY	Panel	QTY	Connectors	QTY
 24" x 18 1/2"	2	 24" x 15 1/2"	2		2
					2

5.6

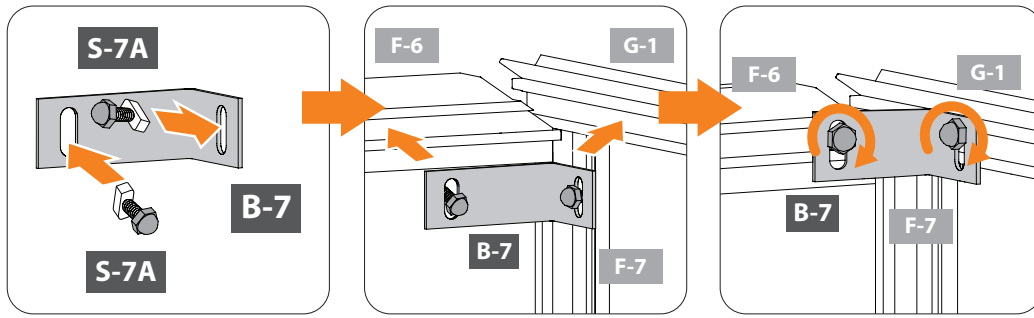

x2

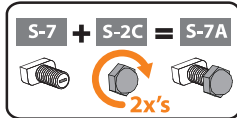

Connectors		QTY	Connectors		QTY
	S-7	4		B-7	2
				S-2C	4

5.7A

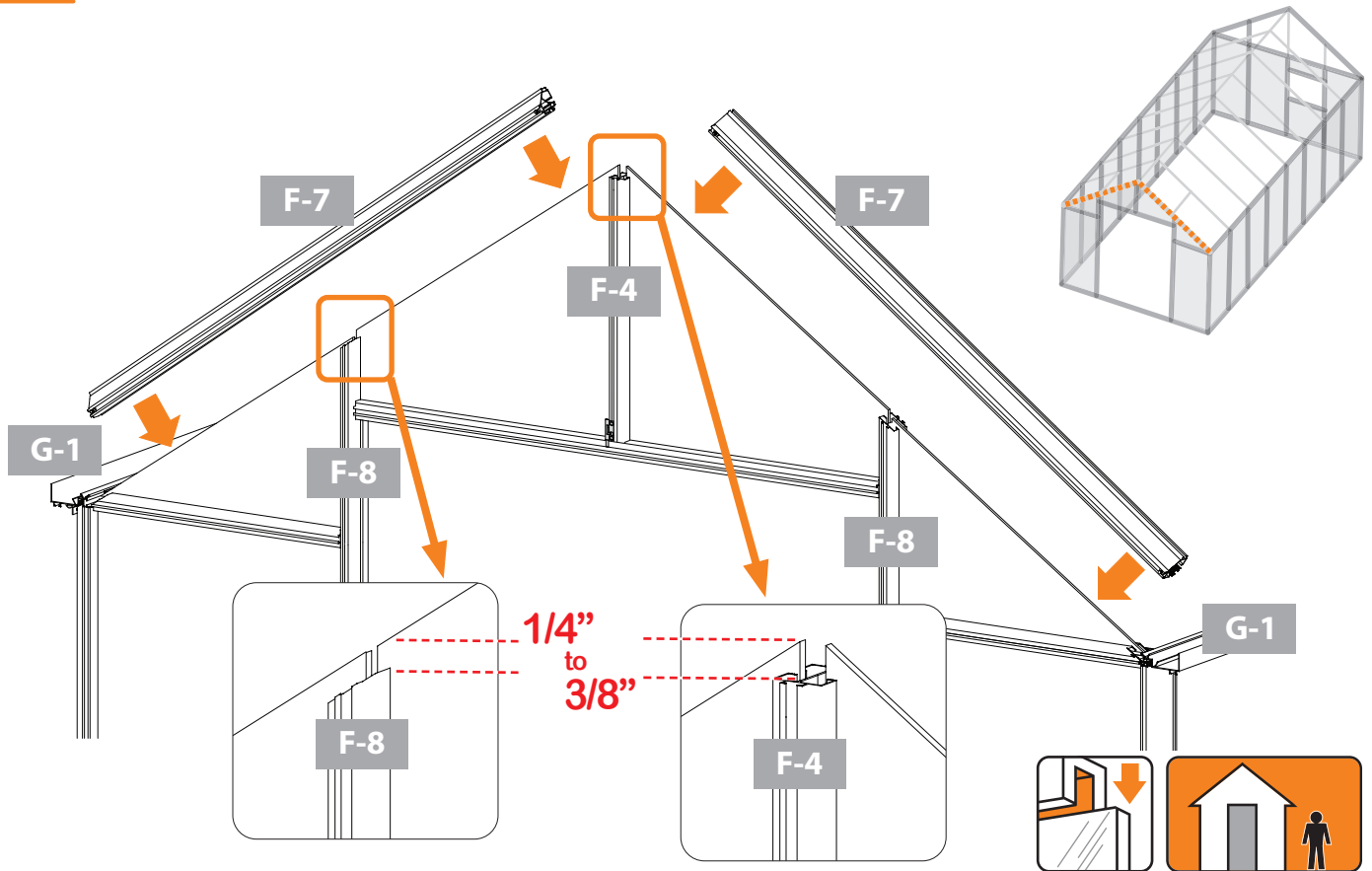

NOTE: The top edge of W-5 panels should extend 1/4" to 3/8" above profile to ensure F-7 (see 5.7A) channel securely holds the polycarbonate panel.

REMARQUE: Le bord supérieur des panneaux W-5 doit s'étendre de 1/4" à 3/8" au-dessus du profil pour s'assurer que le canal F-7 (voir 5.7A) maintient solidement le panneau en polycarbonate.

NOTA: El borde superior de los paneles W-5 debe extenderse de 1/4" a 3/8" por encima del perfil para garantizar que el canal F-7 (ver 5.7A) sujeta firmemente el panel de polycarbonato.

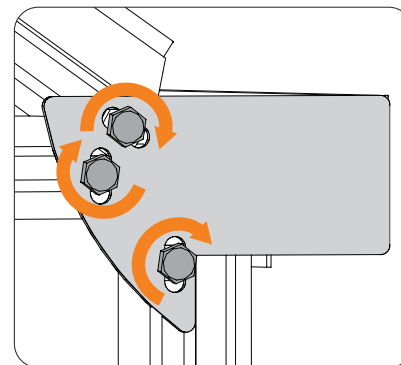
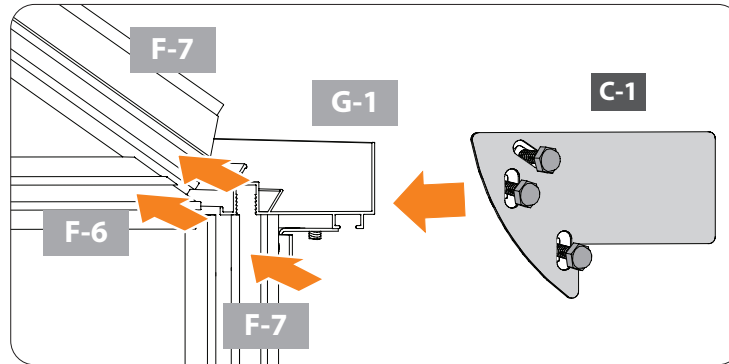
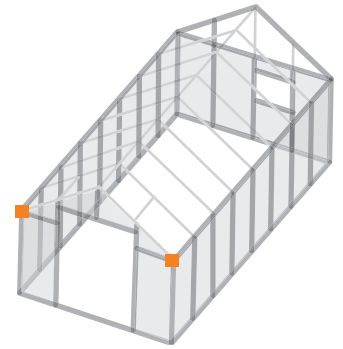
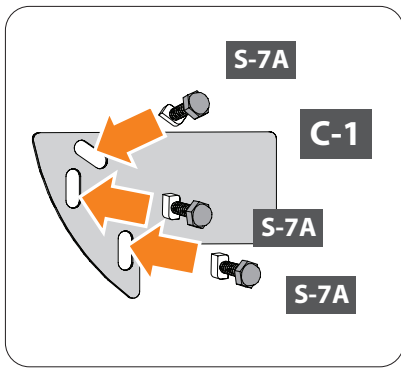

Profile		QTY
	56"	F-7 2

5.7B

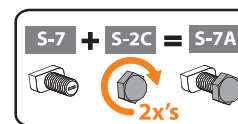

5.7B x 2

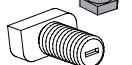

Connectors		QTY
	C-1	2
	S-2C	6
	S-7	6

5.8

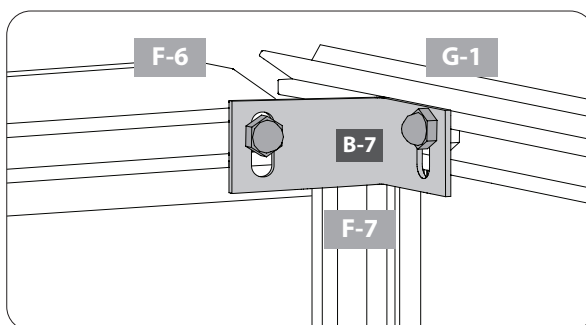

Check inside corners to ensure **B-7** connector is still in proper position. If it needs adjusting, repeat **step 5.6** until each corner is set.

Vérifiez les coins intérieurs pour vous assurer que le connecteur B-7 est toujours dans la bonne position. S'il doit être ajusté, répétez l'étape 5.6 jusqu'à ce que chaque coin soit défini.

Revisa las esquinas interiores para asegurarse de que el conector B-7 todavía esté en la posición correcta. Si necesita un ajuste, repita el paso 5.6 hasta que se establezca cada esquina.



Assemble Back Gable

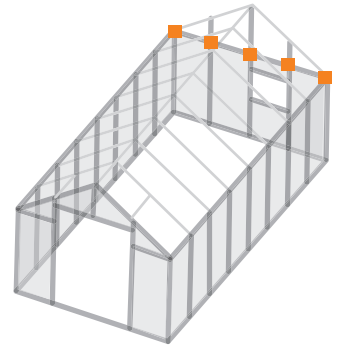
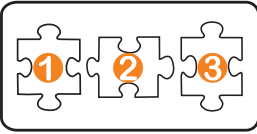

6.1

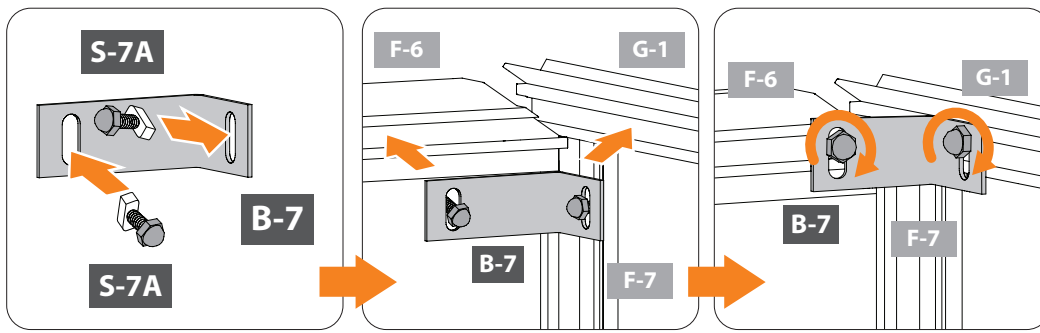

x2

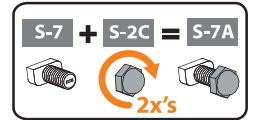

6.2A

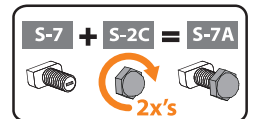
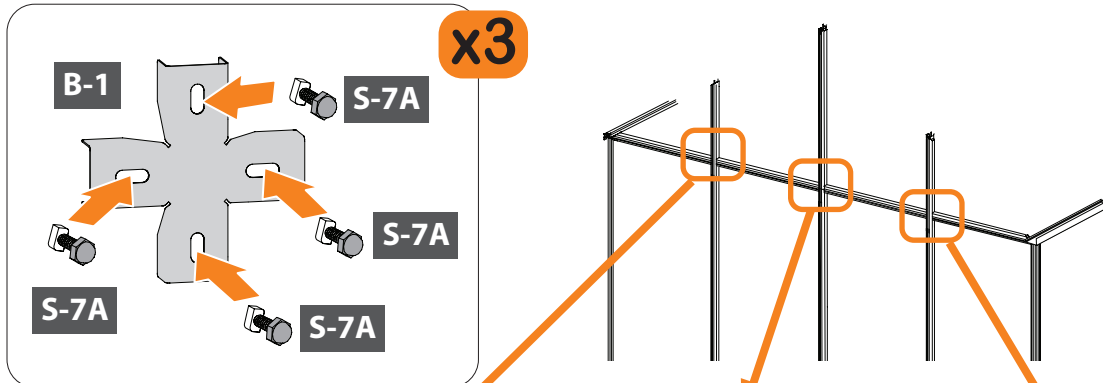

6.2B

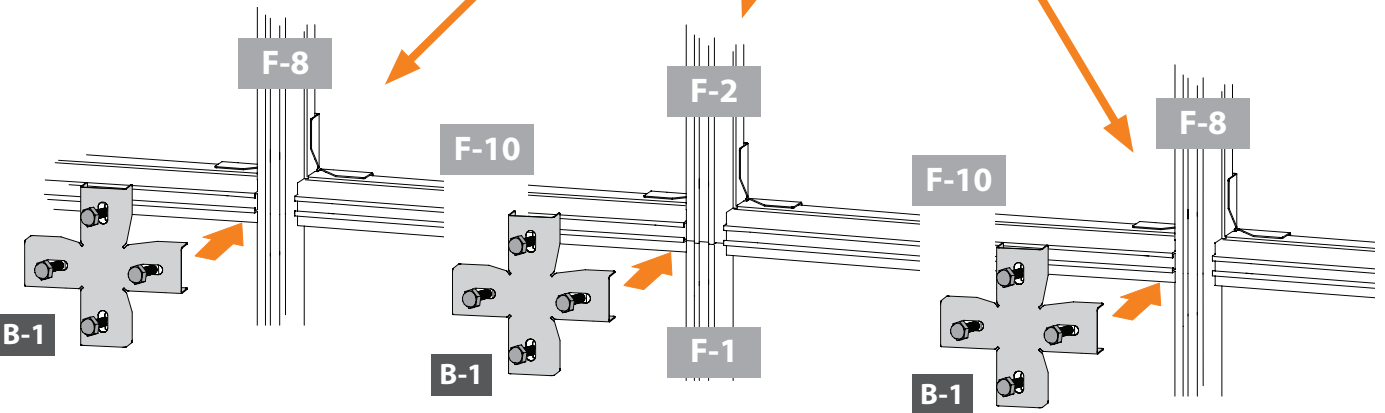

6.2C

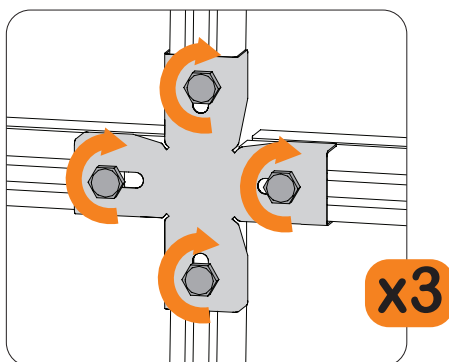

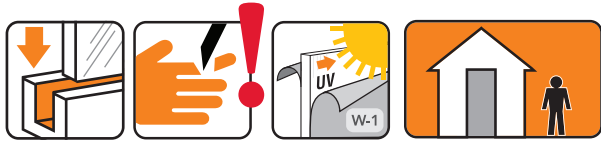
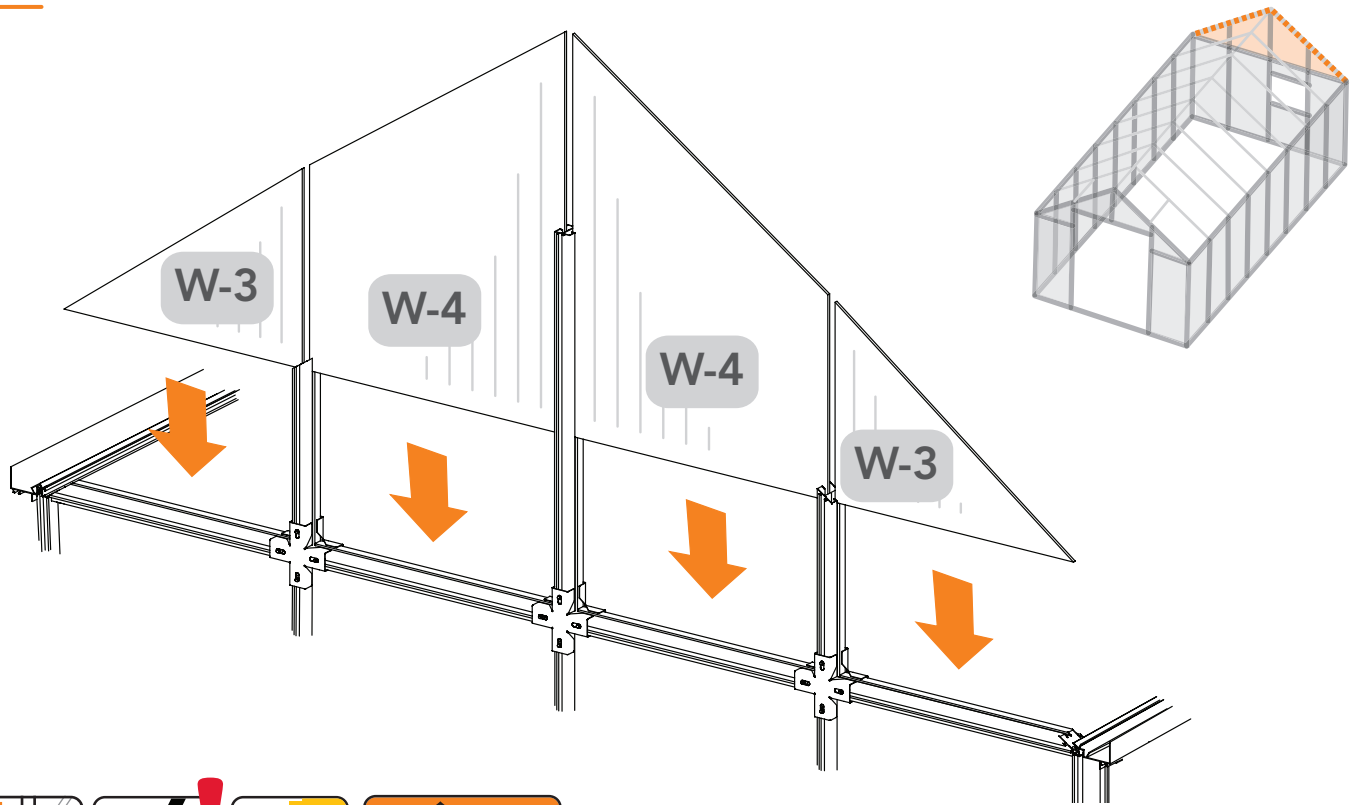

Connectors	QTY	Connectors	QTY		
	B-1	3		S-2C	16
	B-7	2		S-7	16

6.3

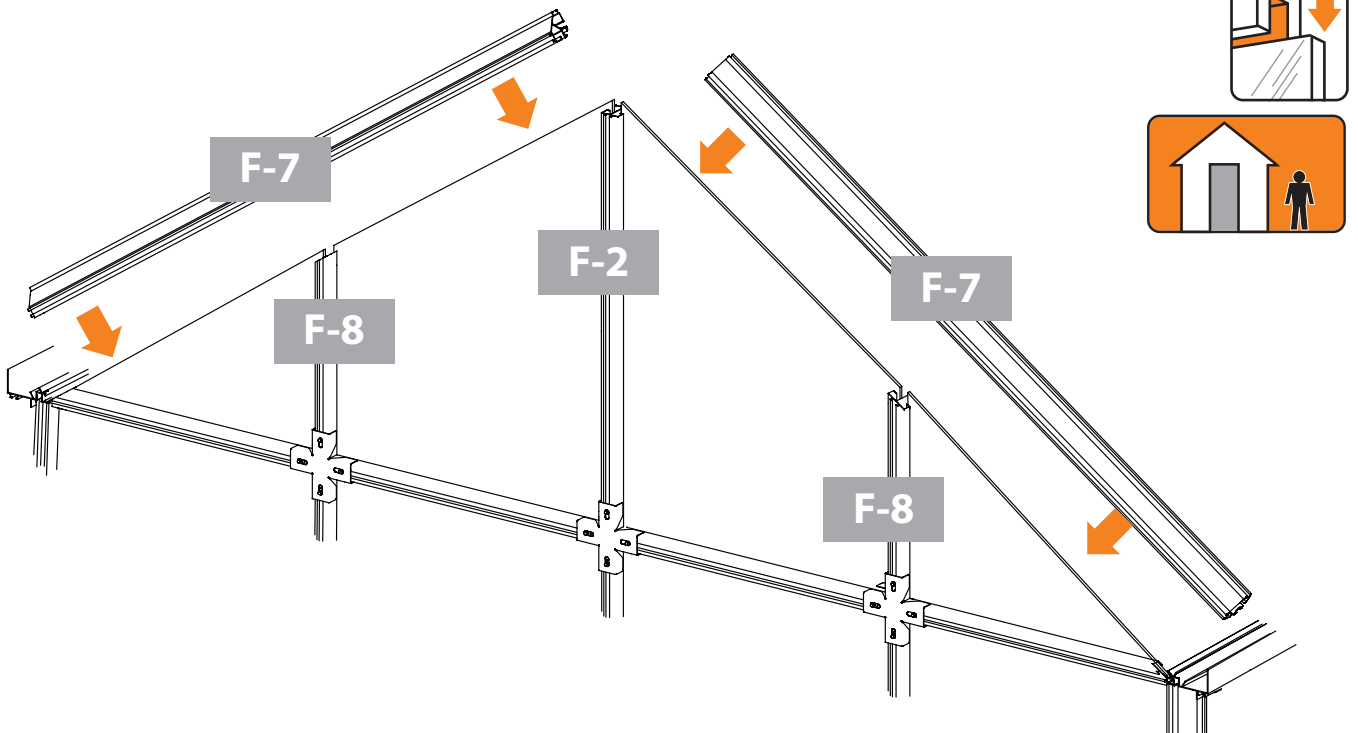

6.4A

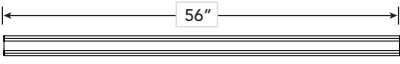
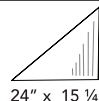
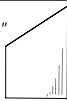

Profile	QTY	Panel	QTY	Panel	QTY
 	2		2		2

6.4B

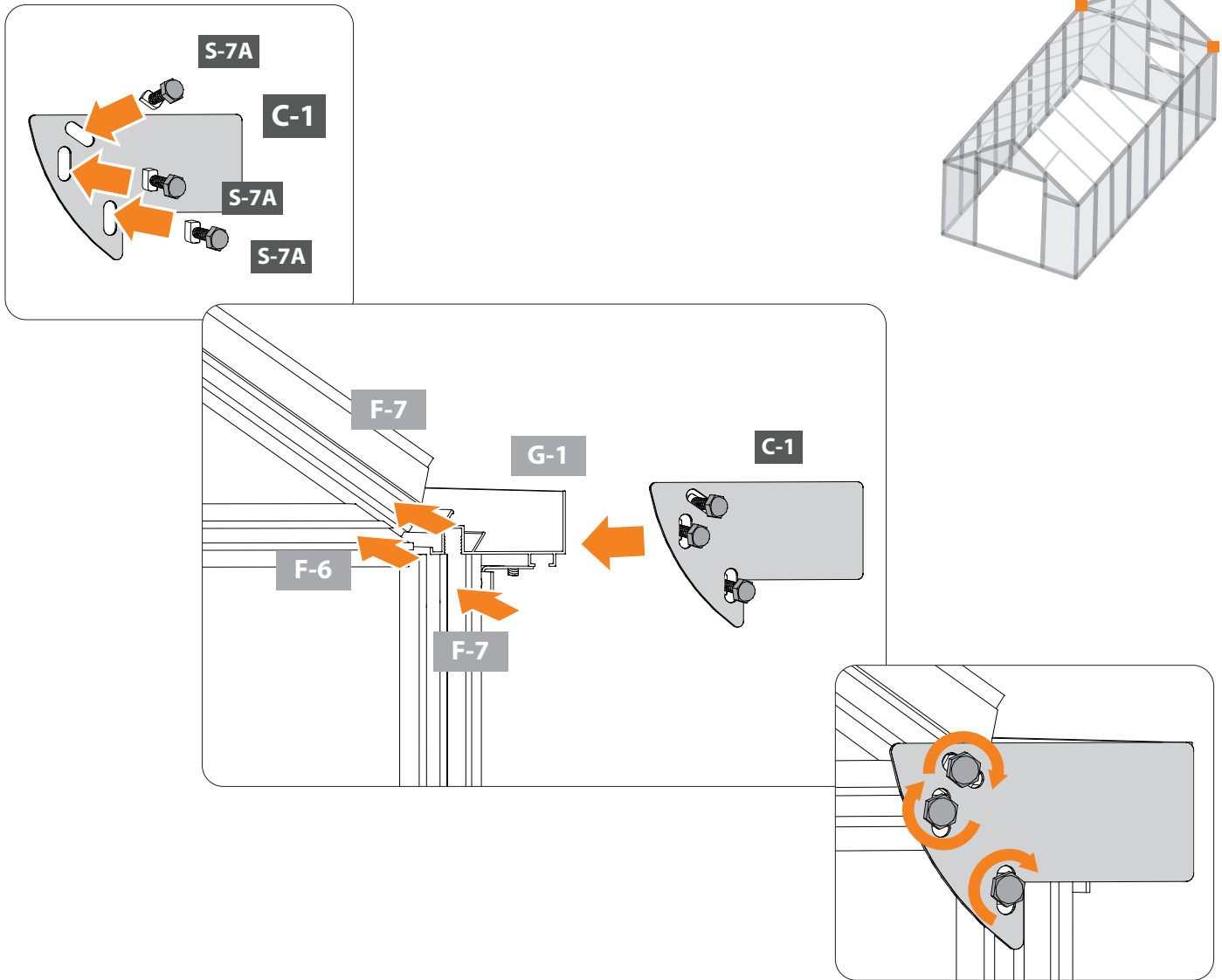

x2

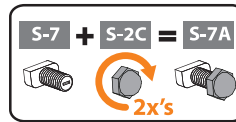

Connectors		QTY
	C-1	2
	S-2C	6
	S-7	6

6.5

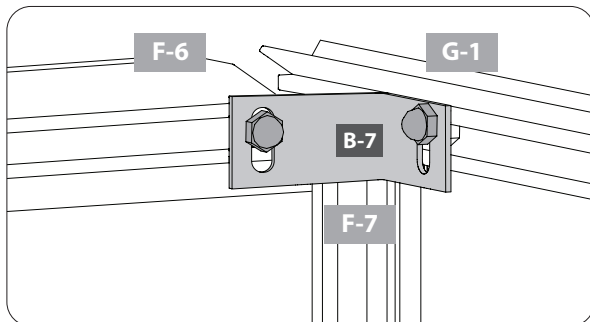

Check inside corners to ensure **B-7** connector is still in proper position. If it needs adjusting, repeat **step 5.6** until each corner is set.

Vérifiez les coins intérieurs pour vous assurer que le connecteur **B-7** est toujours dans la bonne position. S'il doit être ajusté, répétez l'étape 5.6 jusqu'à ce que chaque coin soit défini.

Revise las esquinas interiores para asegurarse de que el conector **B-7** todavía esté en la posición correcta. Si necesita un ajuste, repita el paso 5.6 hasta que se establezca cada esquina.



Install Pre-Assembled Roof Ridge

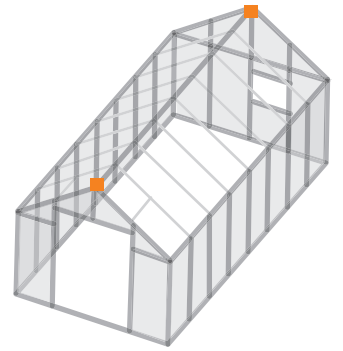
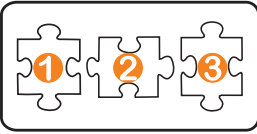

(7.1A - 7.2B) (see page 31)

7.3A

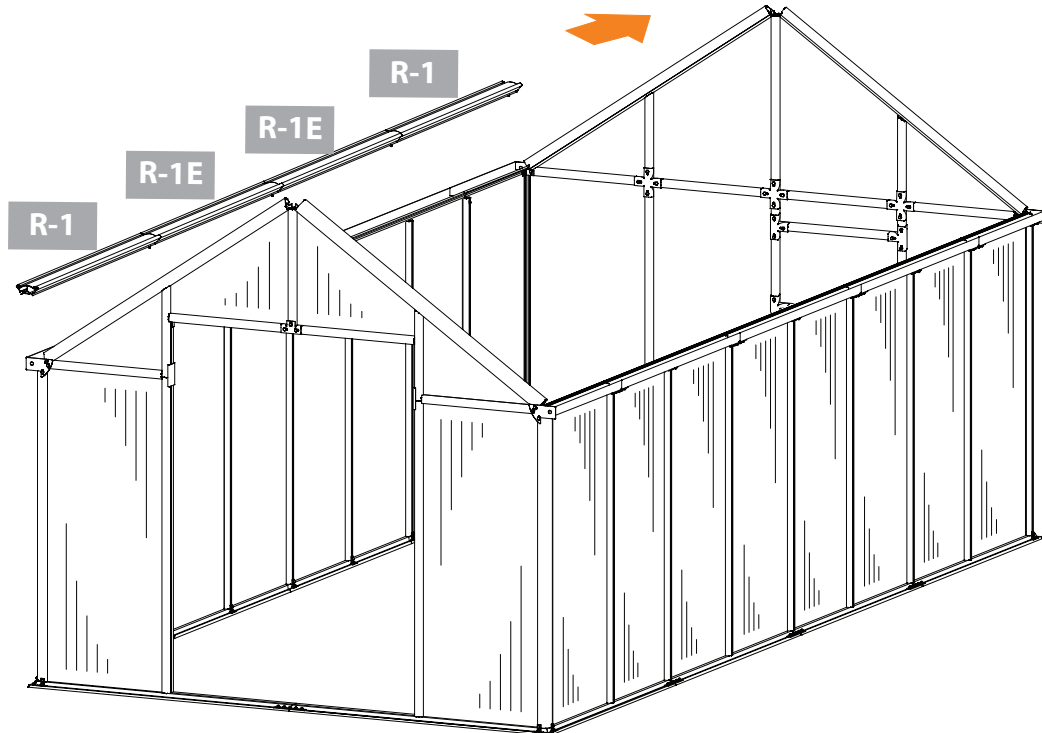
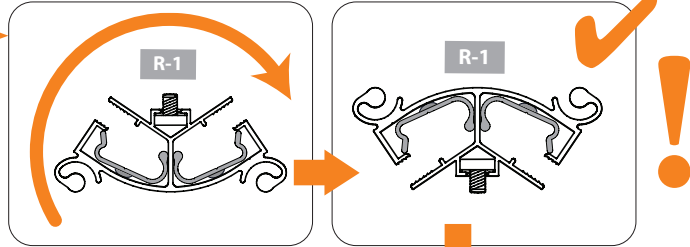
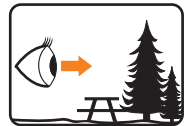

7.3B

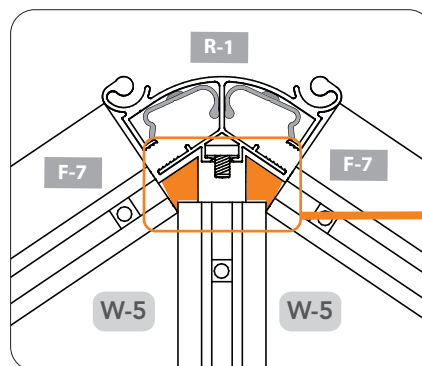
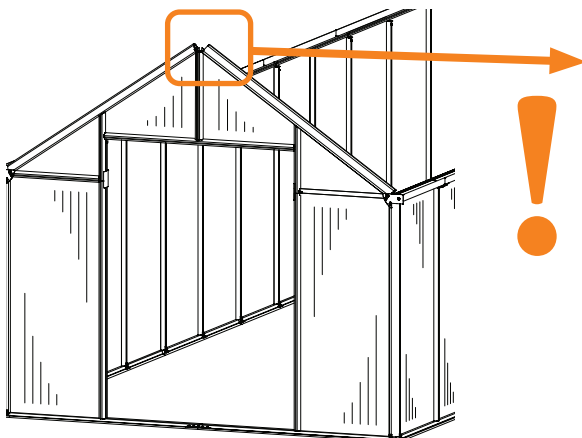

7.3C

x2

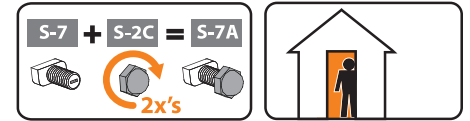
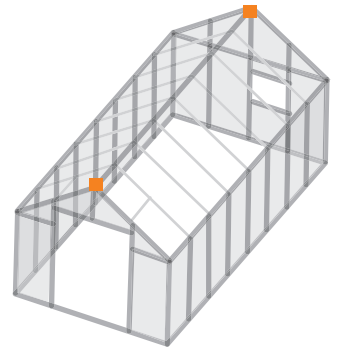
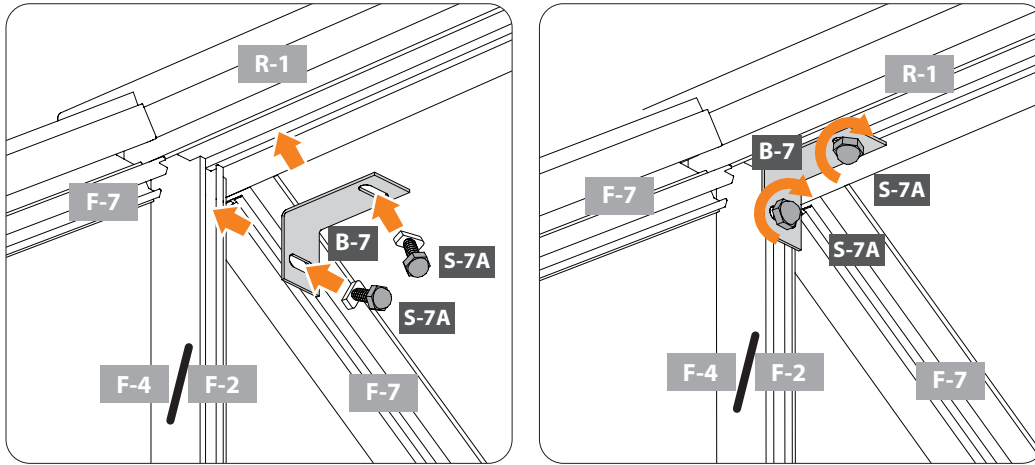

7.4

x2

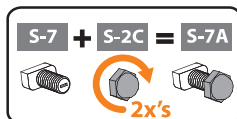
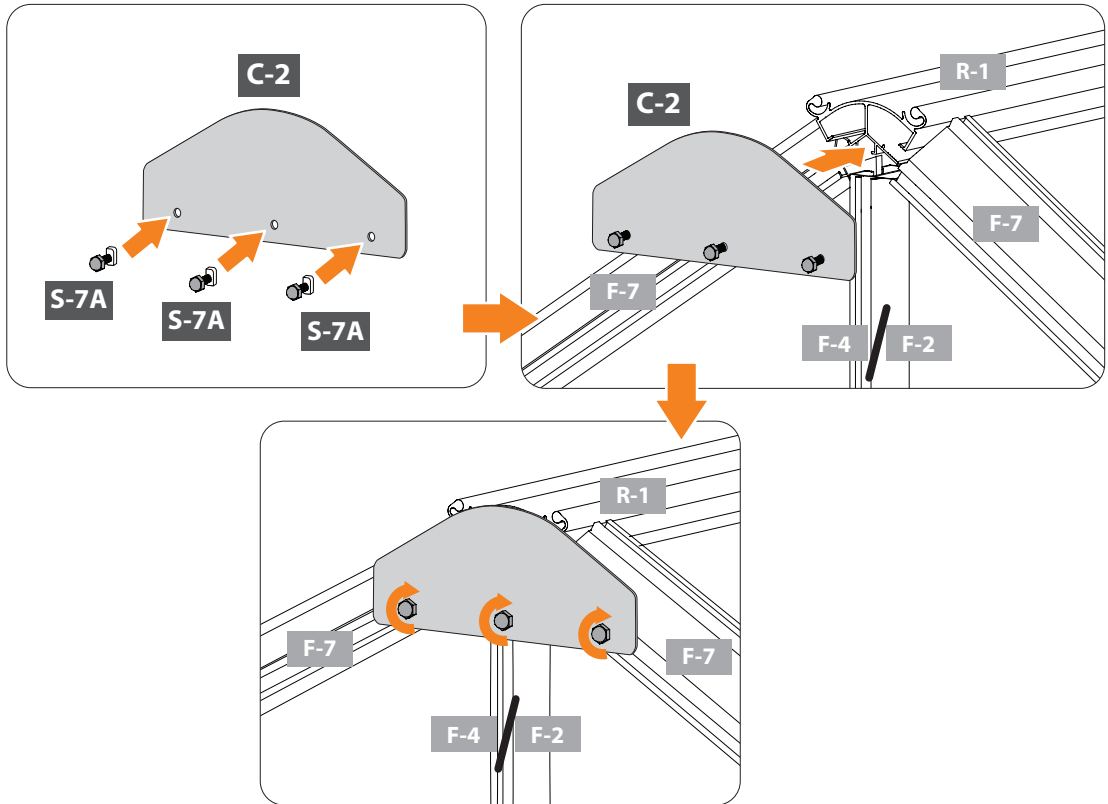

Connectors		QTY	Connectors		QTY
	C-2	2		B-7	2
	S-2C	10		S-7	10

Assemble Roof

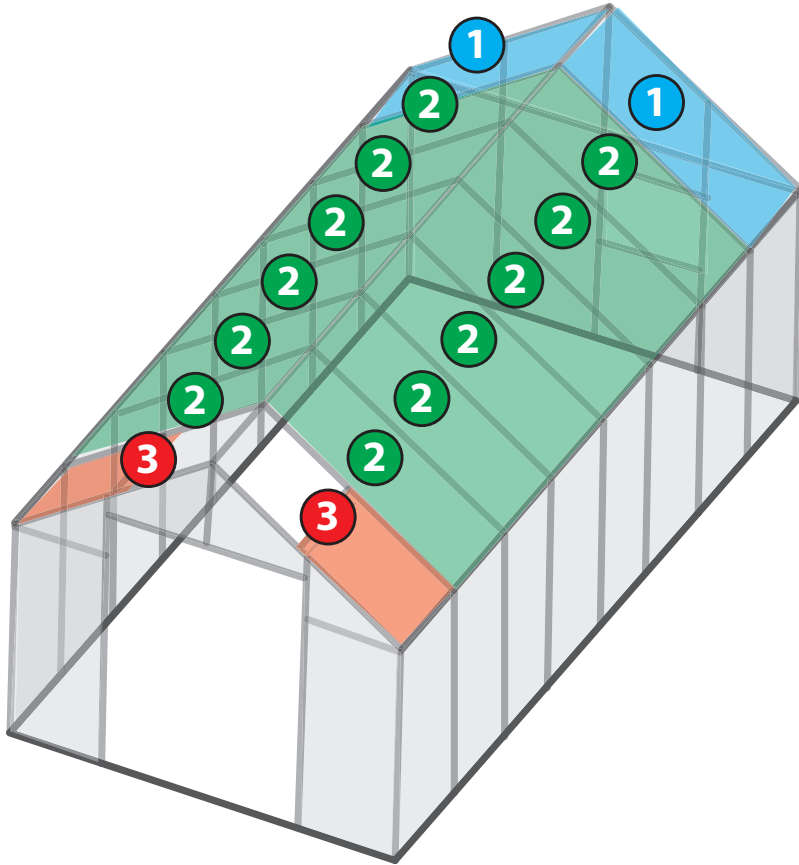
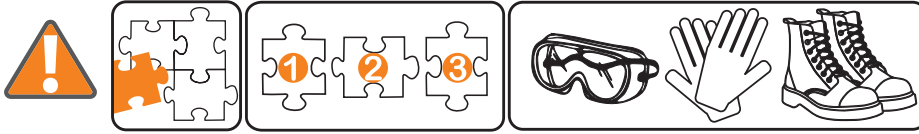

Section 1: W-8 x 2

Section 2: W-8 x 12

Section 3: W-10 x 2



Materials: Two 8' 2x4s cut to 78" +/- 2" based on type of flooring.

Matériaux: Deux 8' 2x4 coupés à 78" +/- 2" selon le type de revêtement de sol.

Materiales: Dos 8' 2x4 cortados a 78" +/- 2" según el tipo de piso.

8.1

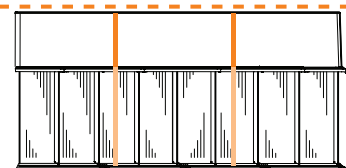
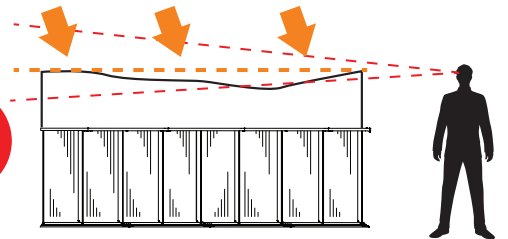
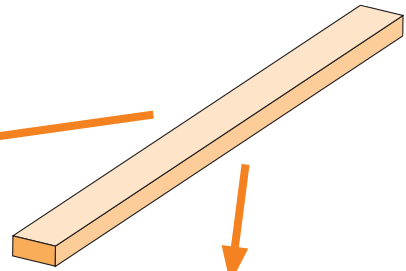
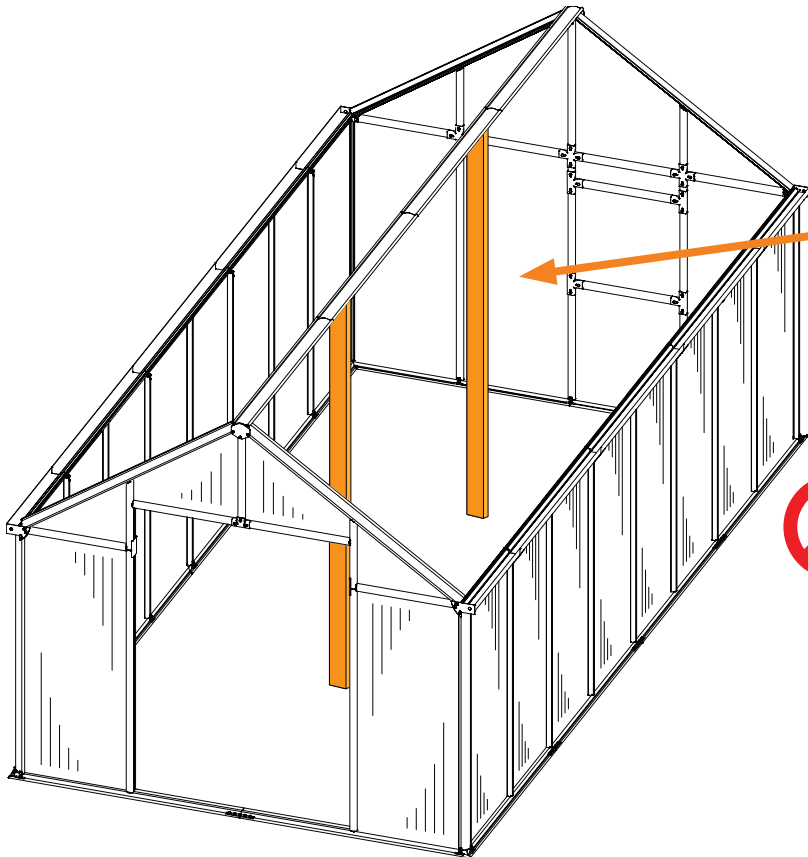

8.2A

1

W-8

x2

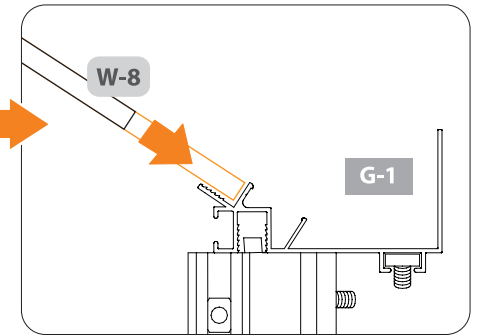
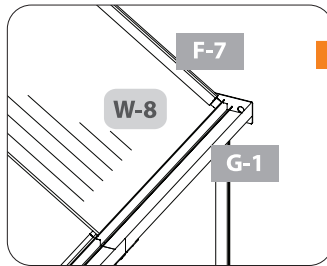
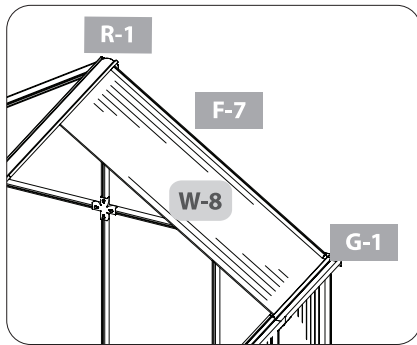
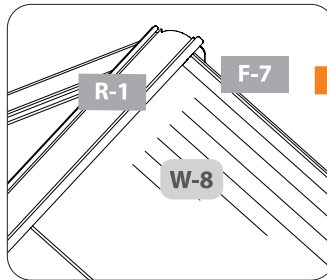
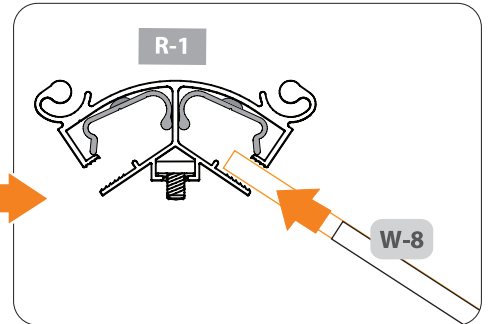
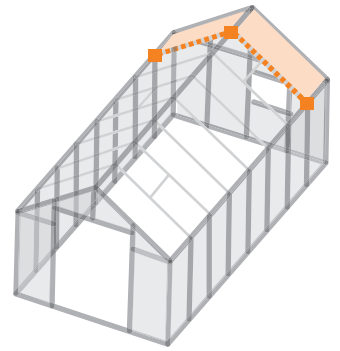
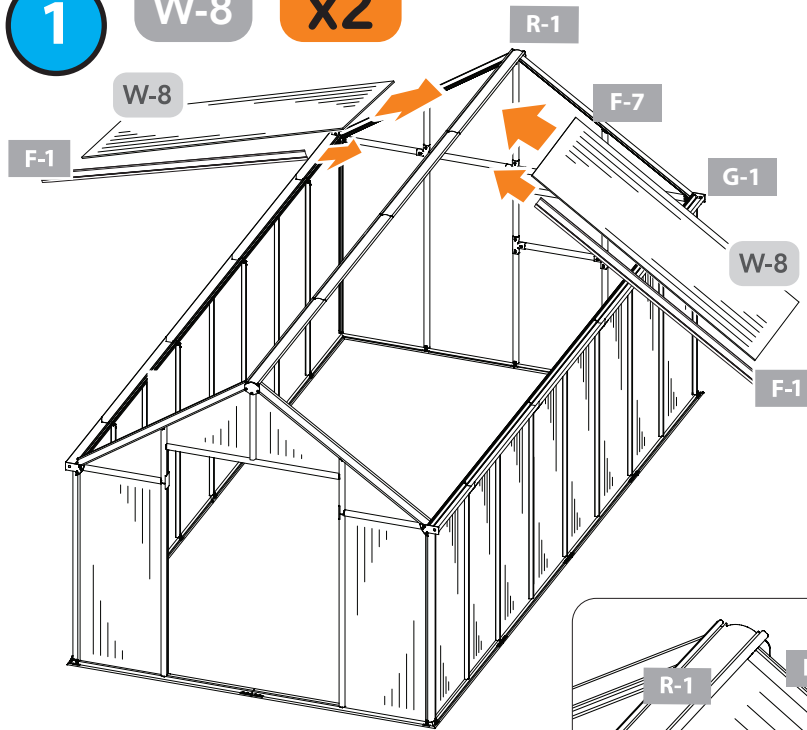

8.2B

F-1

x2

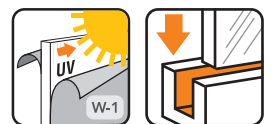
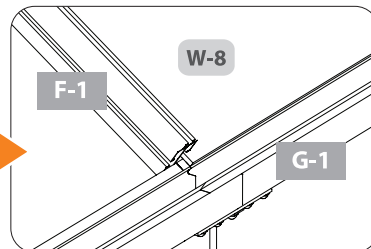
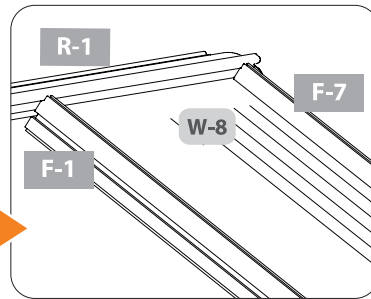
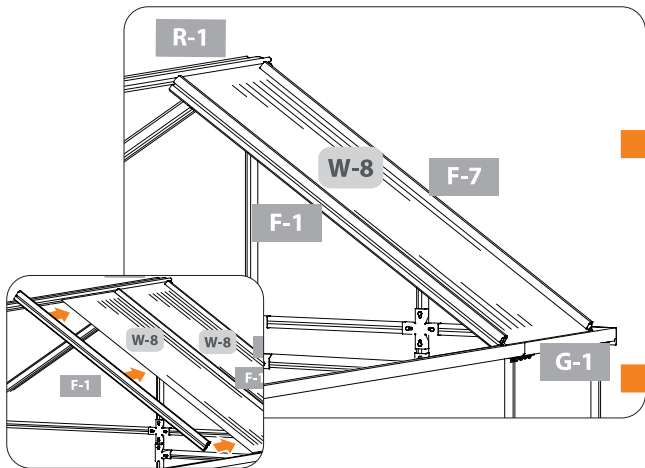

Profile	QTY	Panel	QTY
	F-1		W-8
	2		2

8.2C

x2

B-4

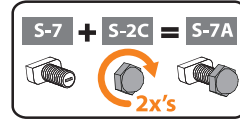
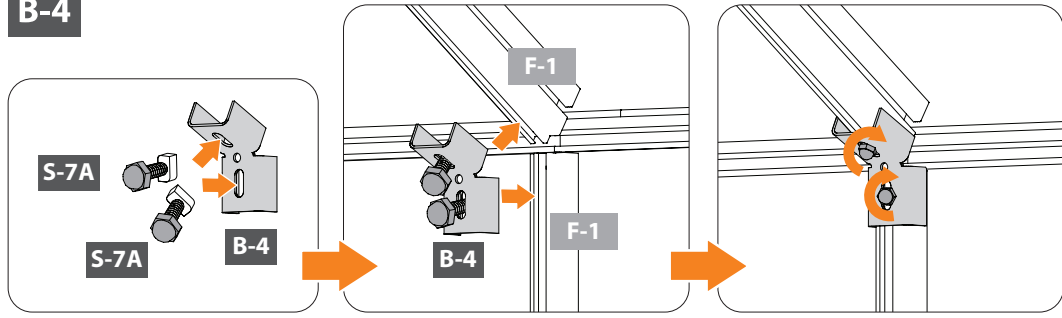

8.2D

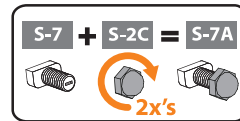
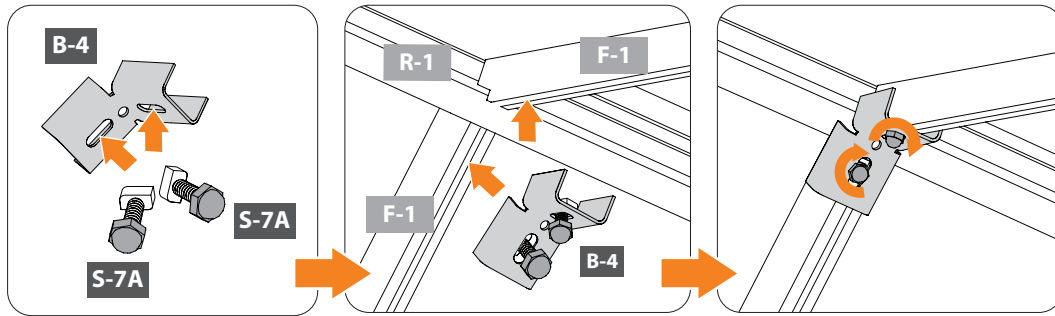

8.3A

2

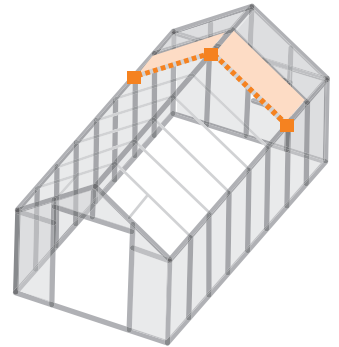
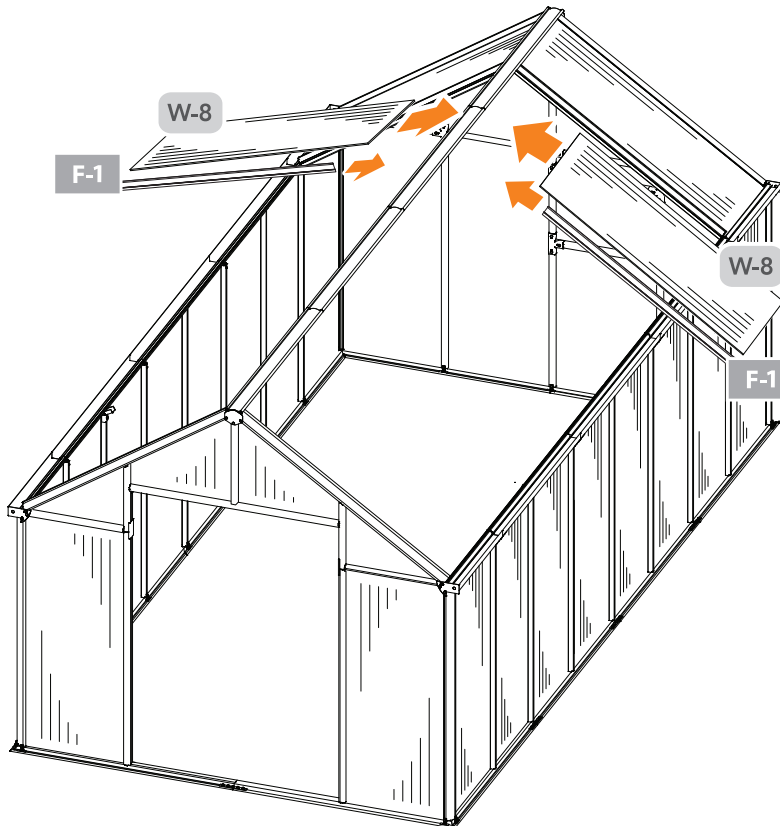

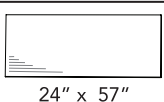
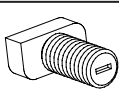
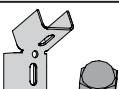
Panel	QTY	Connector	QTY	Connector	QTY
 24" x 57"	W-8	2		S-7	6
				B-4 S-2C	3 6

8.3B

F-1 **x2**

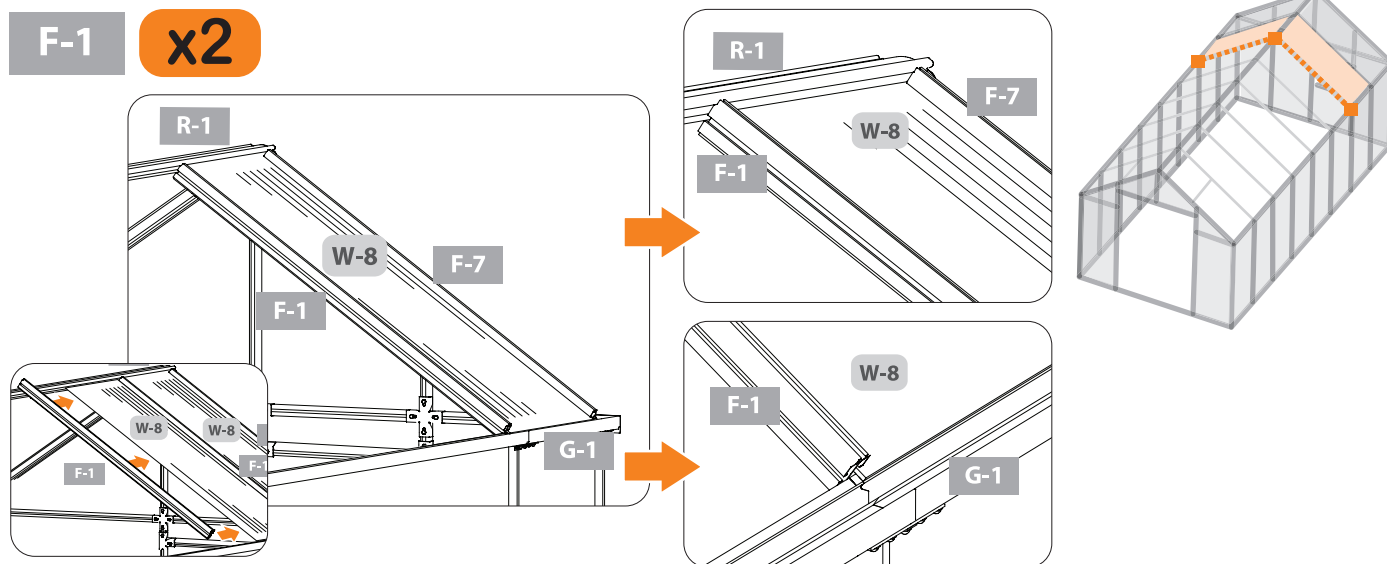

8.3C

B-4

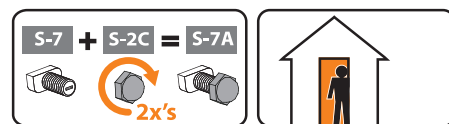
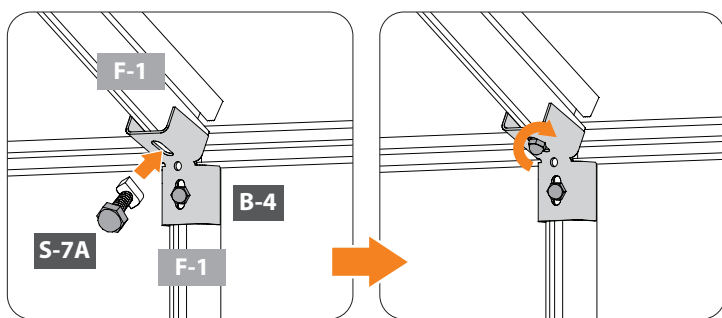

8.3D

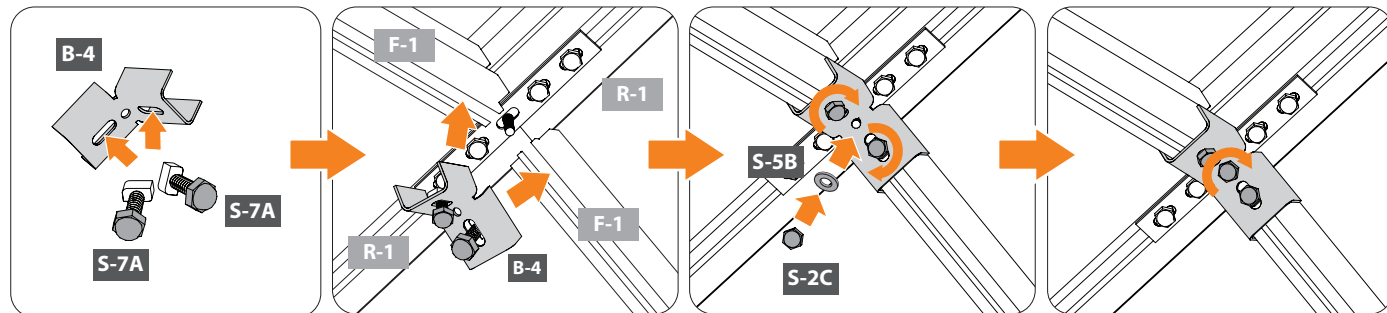

Profile		QTY	Connectors		QTY
	F-1	2		S-5B	1
				B-4	3
				S-2C	7
				S-7	6

8.3F (8.2A - 8.2D) x 1

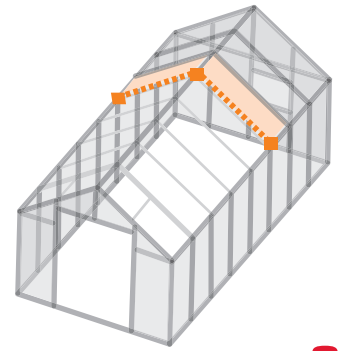
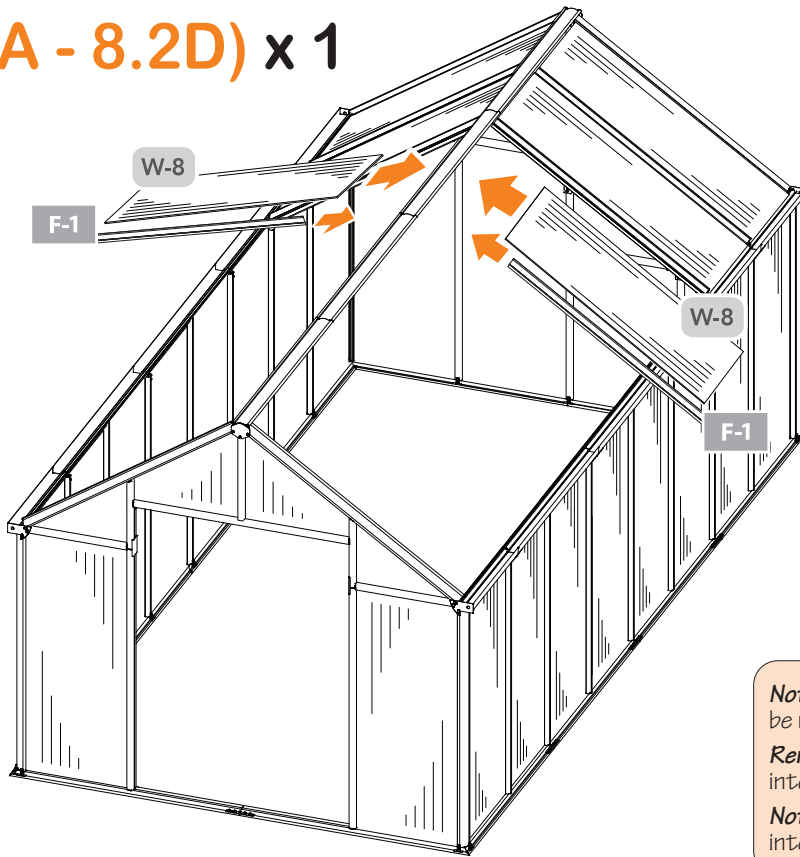

Note: Distance between interior walls should be maintained at 97.5".

Remarque: La distance entre les murs intérieurs doit être maintenue à 97,5 po.

Nota: La distancia entre las paredes interiores debe mantenerse en 97,5".

8.3G (8.3A - 8.3D) x 4

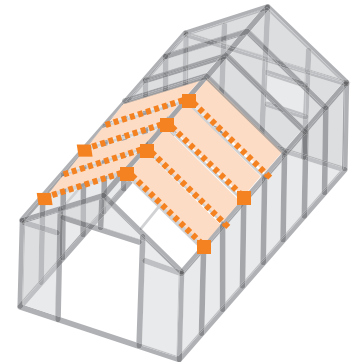
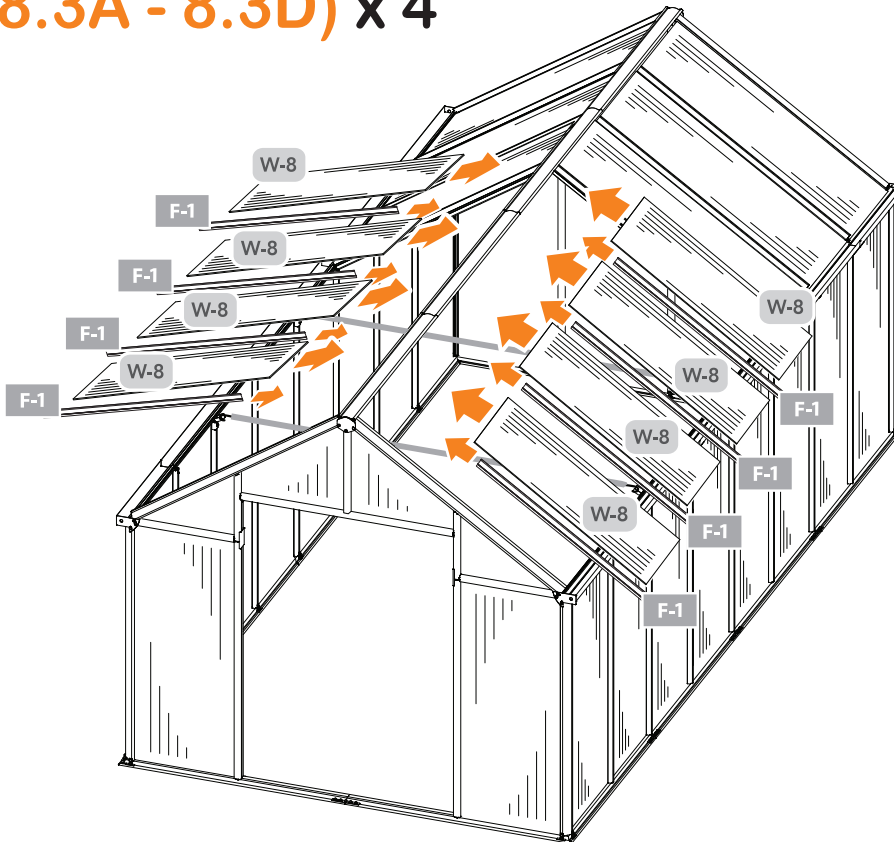

Note: Do NOT secure final F-1 to B-4 before installing W-10 in step 8.4.

Profile	QTY	Panel	QTY
F-1	10	W-8	10

Connectors	QTY
	S-5B 2
	B-4 15
	S-2C 32
	S-7 30

8.4A

3

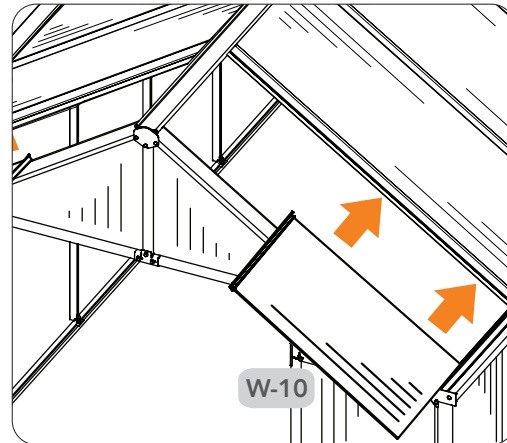
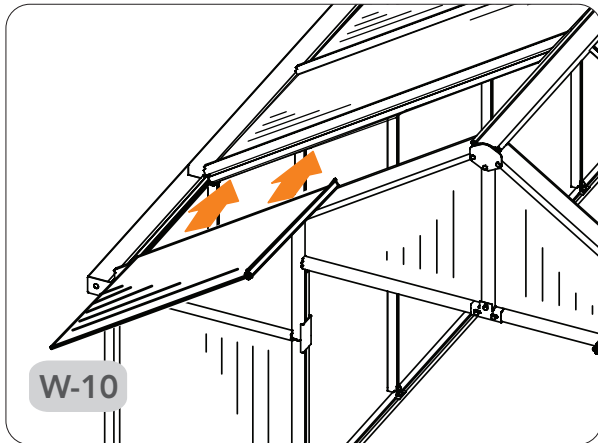
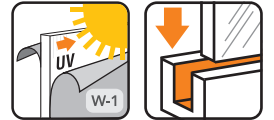
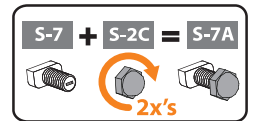
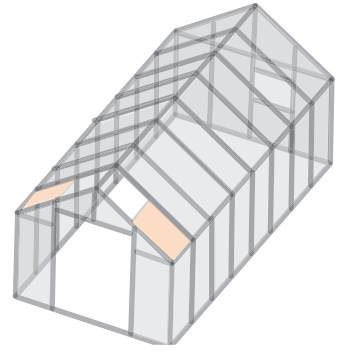
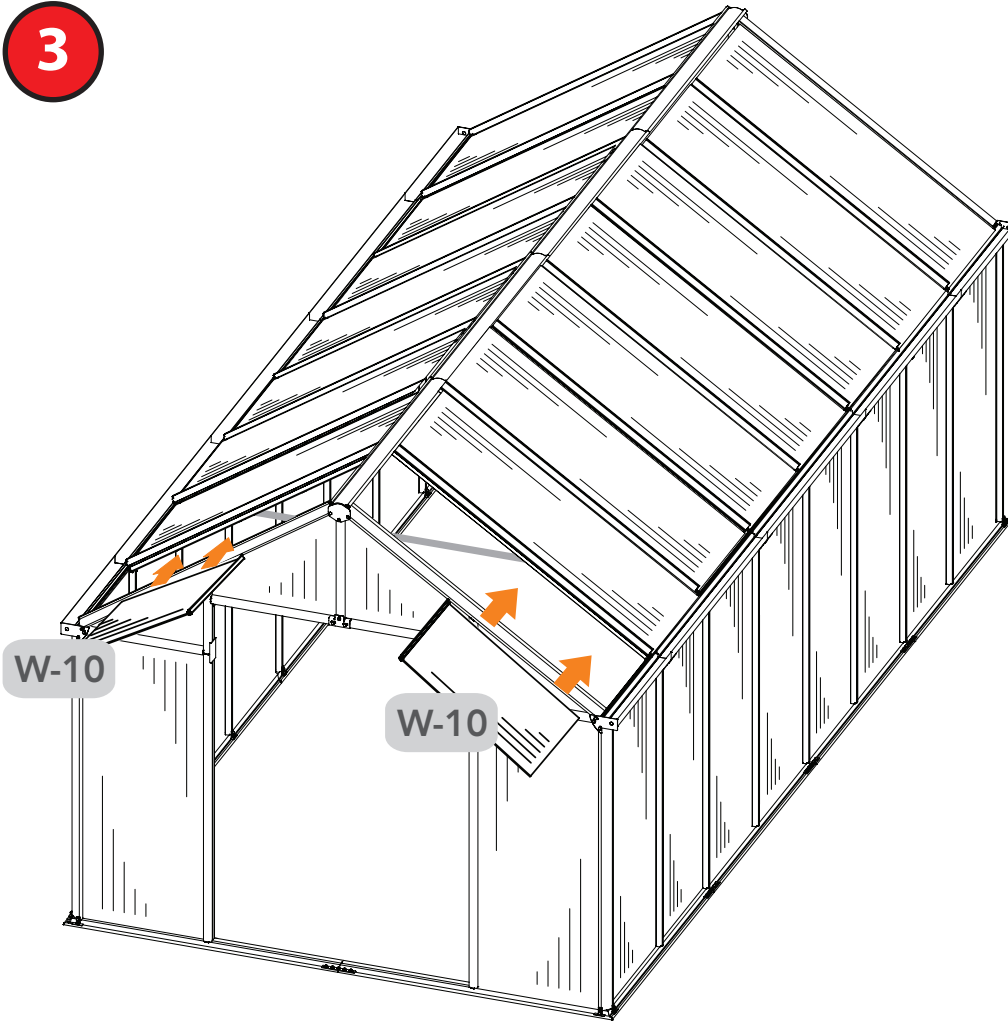

8.4B

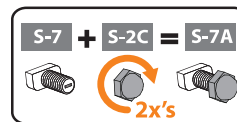
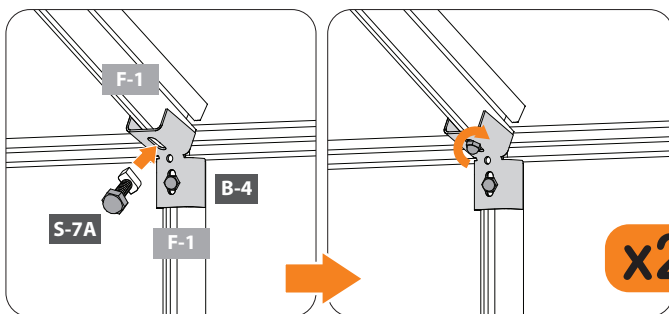

Panel	QTY
	2

8.5A

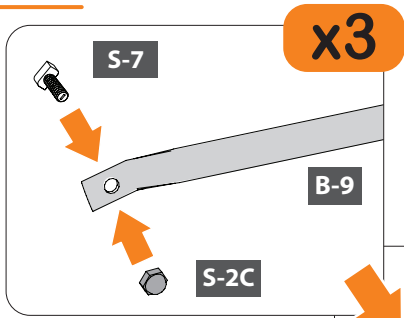

8.5B

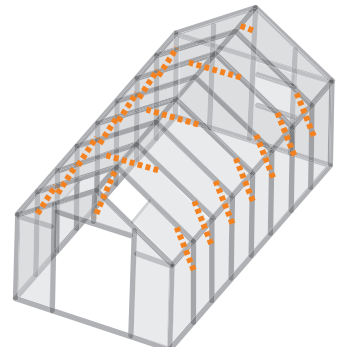
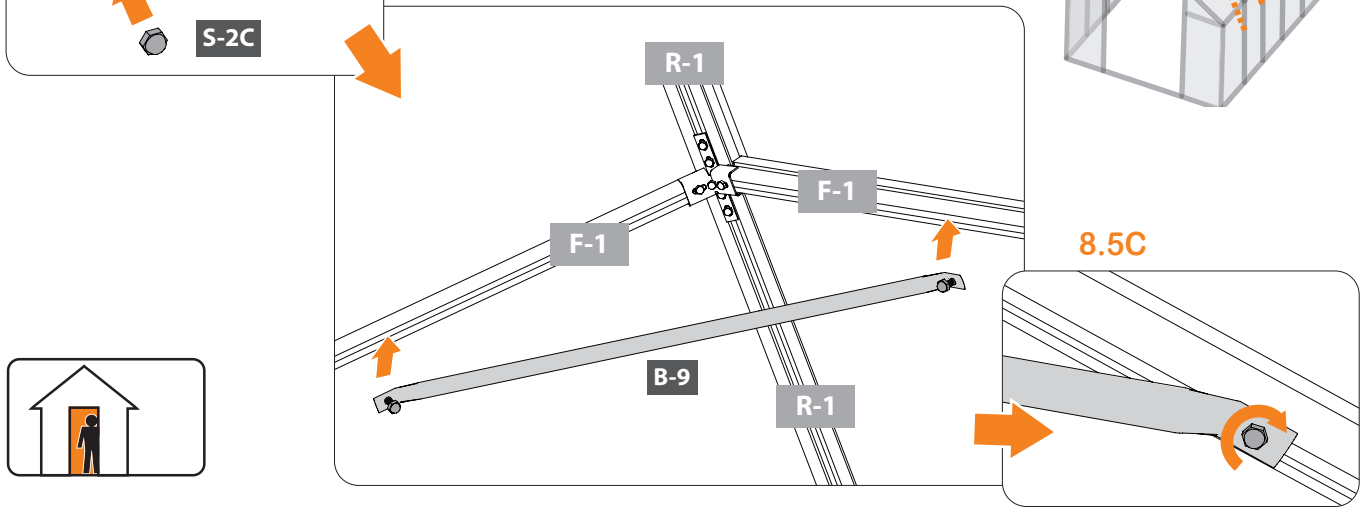

8.5C

8.5D

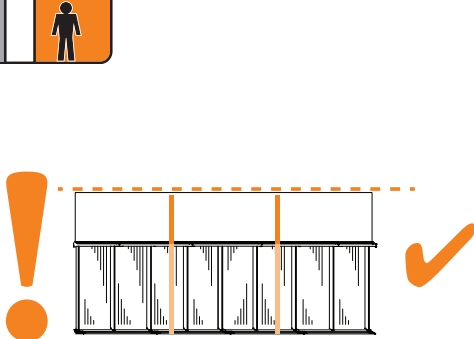
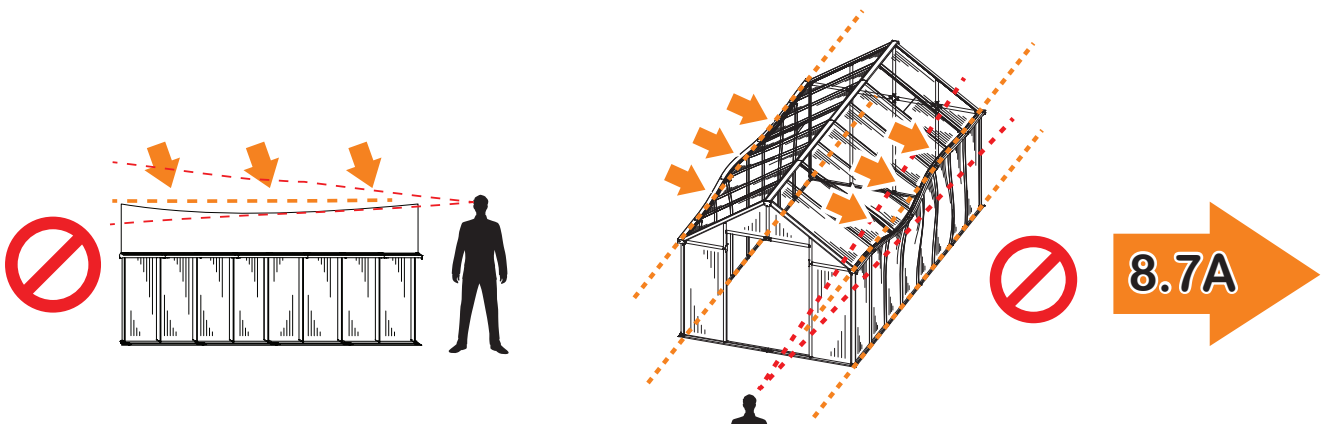

Brace		QTY	Connectors		QTY
	B-9	3		S-2C	6
				S-7	6

8.6A

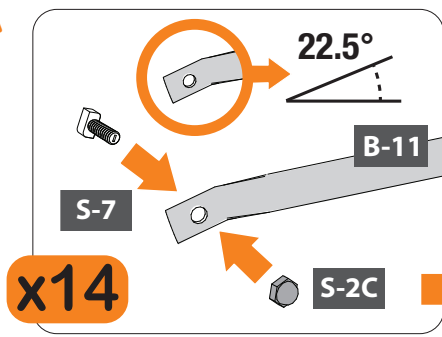

8.6B

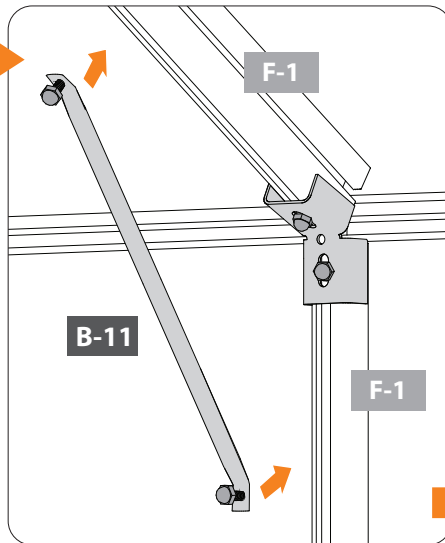

8.6C

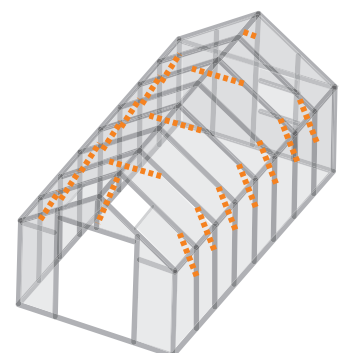
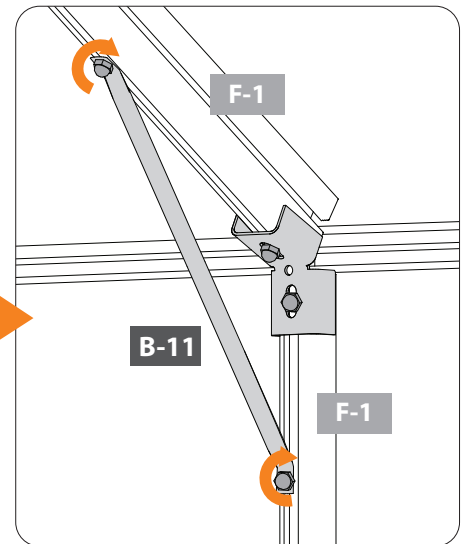

8.6D

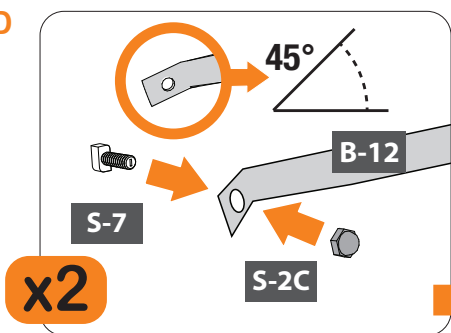

8.6E

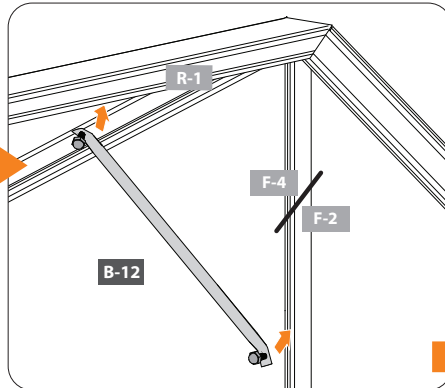



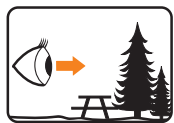
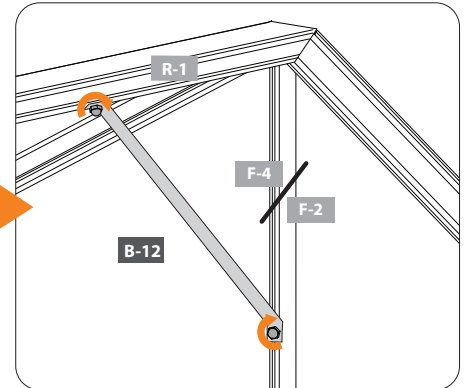

8.6F

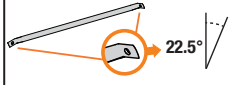

8.6F

➔ (8.8A)

Brace	QTY	Connectors	QTY
	B-11		S-2C
	14		32
	B-12		S-7
	2		32

PRO-TIP Roof Adjustment

8.7A

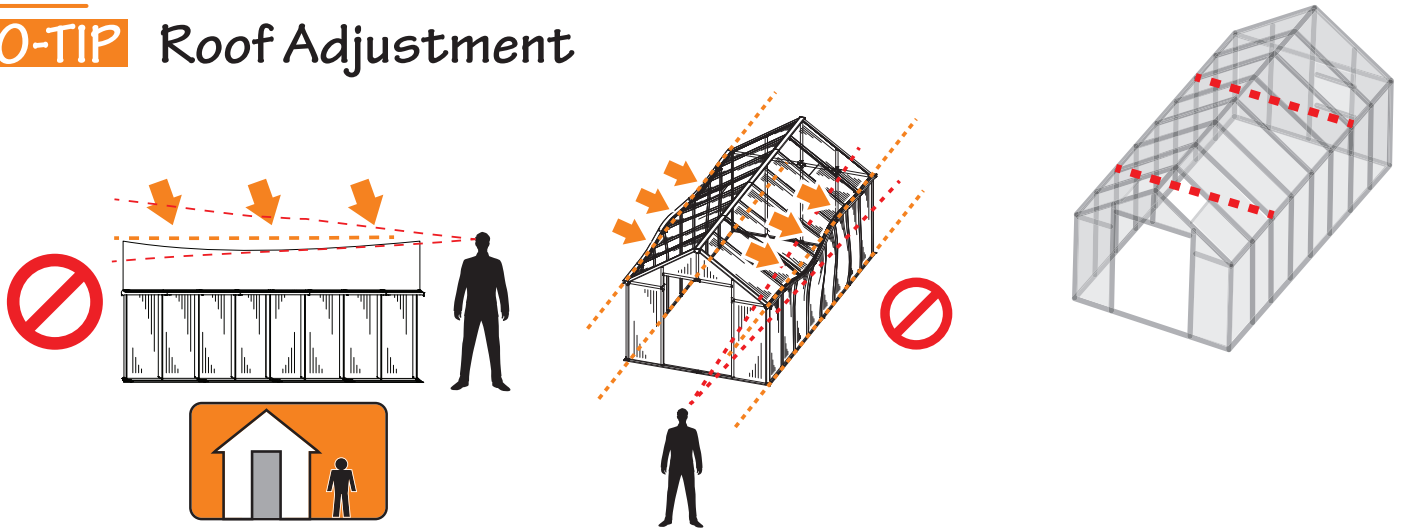

8.7B

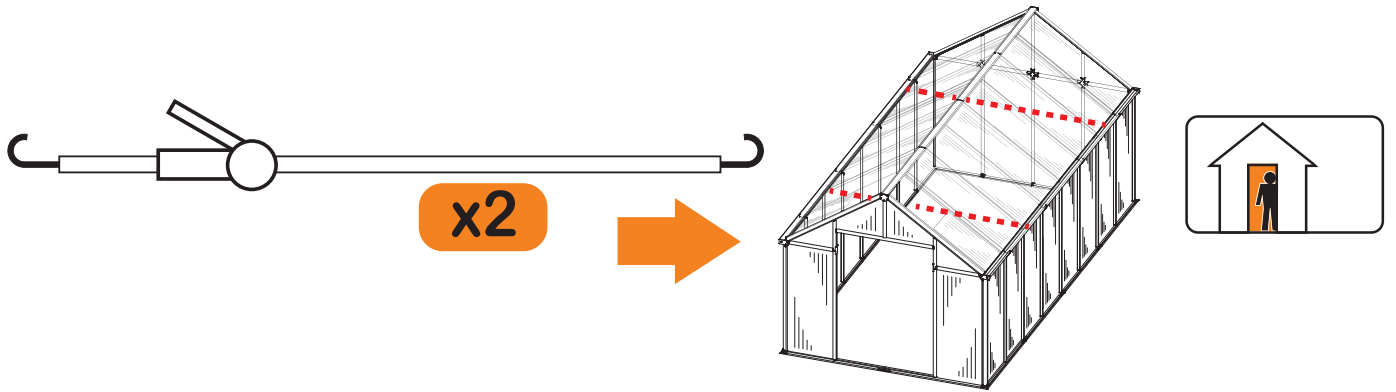

8.7C

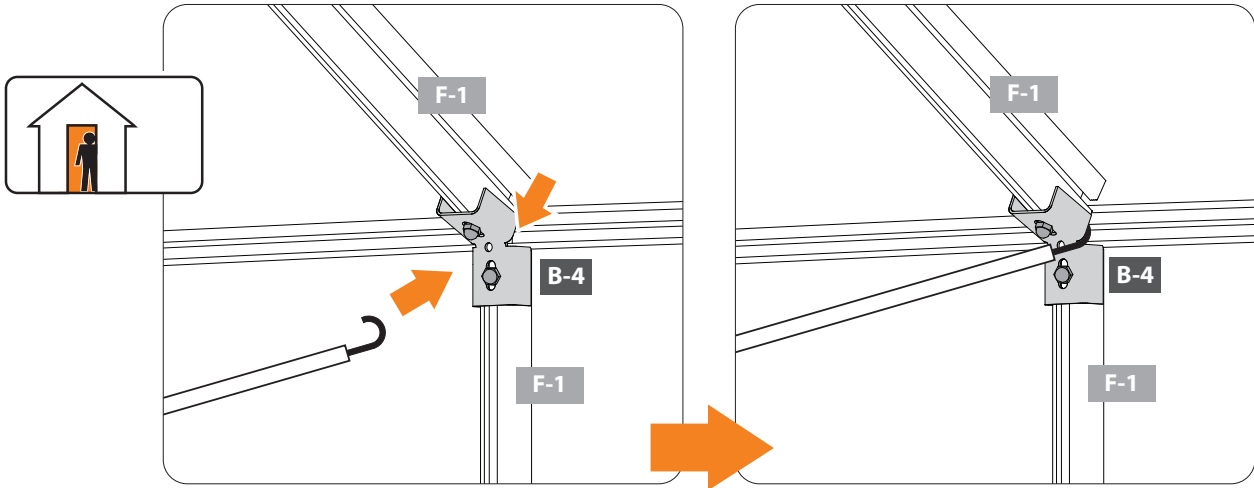

8.7D

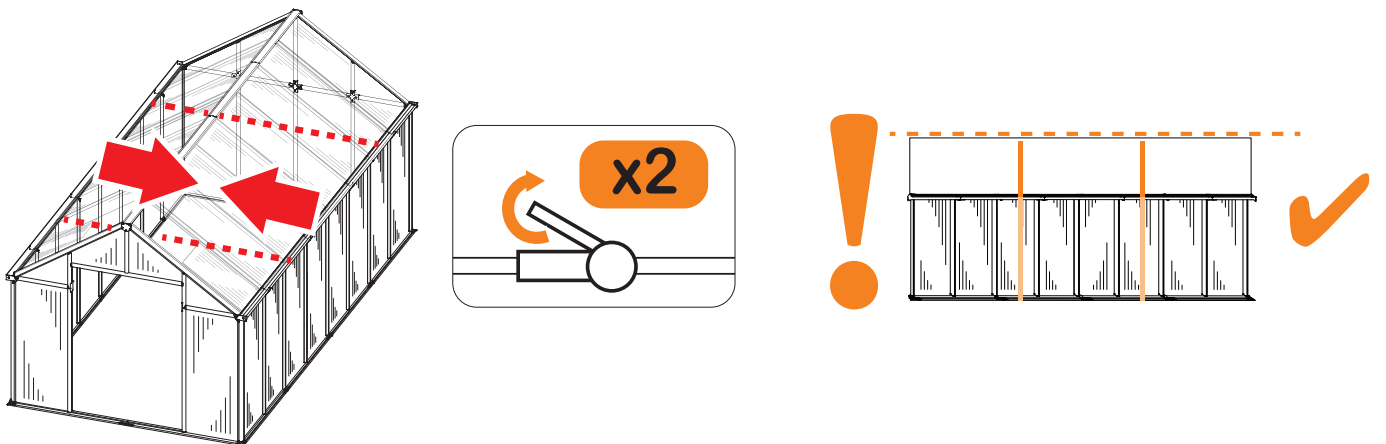

8.8A

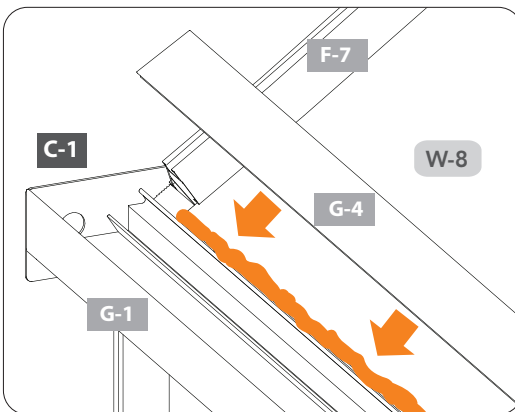
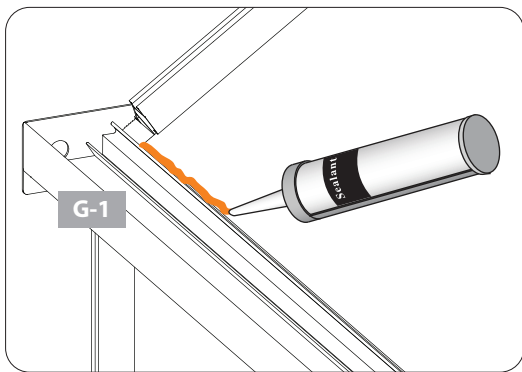

8.8B

8.8D

x8

x10

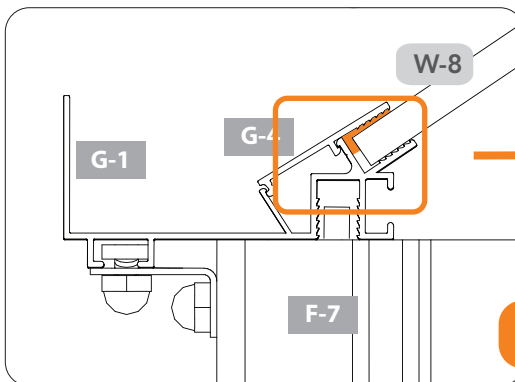
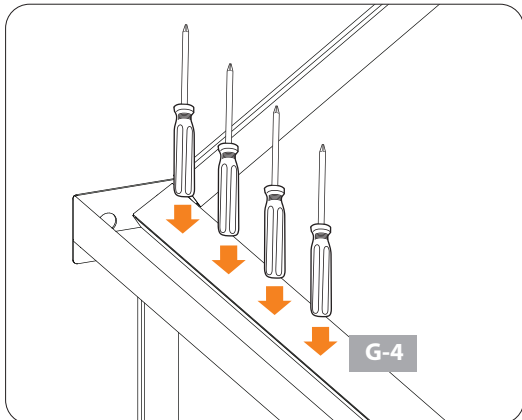

x4

8.8C

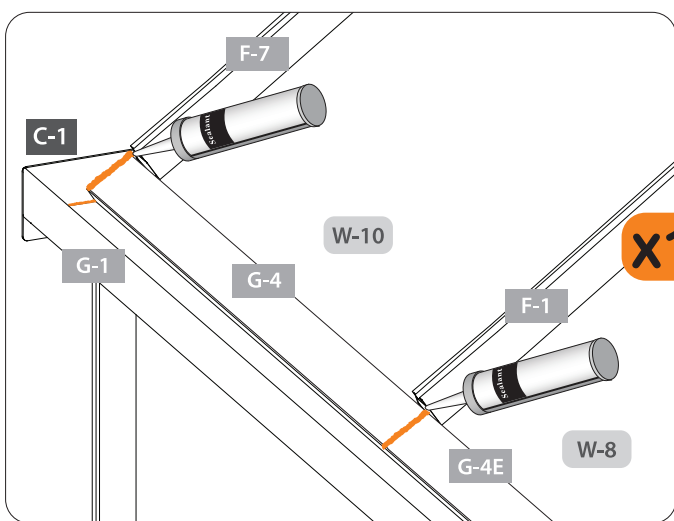

8.8E



Trim Plate	QTY
 49 3/4"	G-4 4
 48 1/2"	G-4E 4

8.9

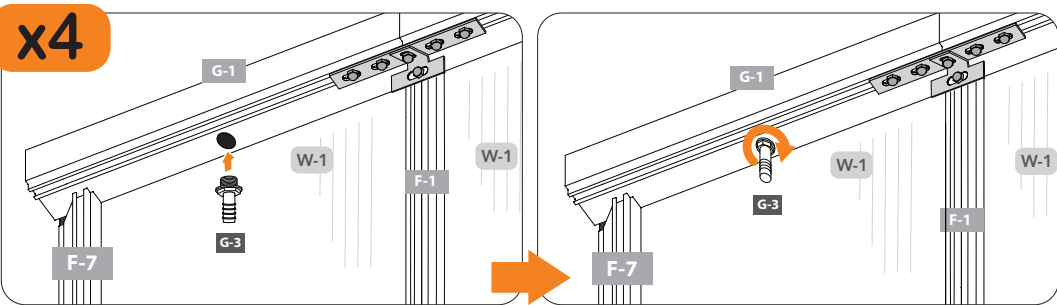

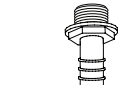
Gutter Drain	QTY
	G-3 4

Install Roof Vents

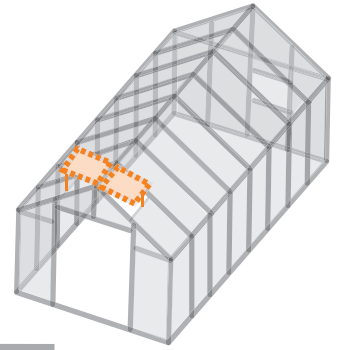
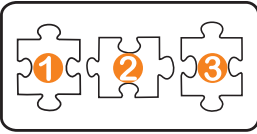

9.1A V-3 VERSION A



adjusting knob

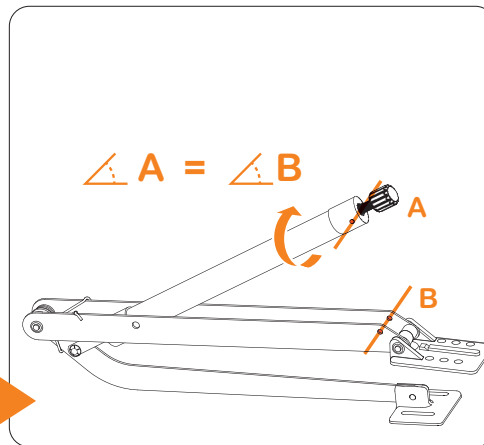
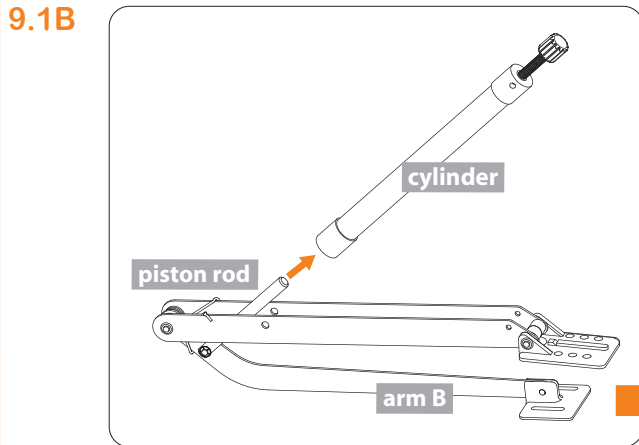

Scan This QR Code!
To be taken to helpful Pro-tips, techniques, and assembly videos!
Reference #06

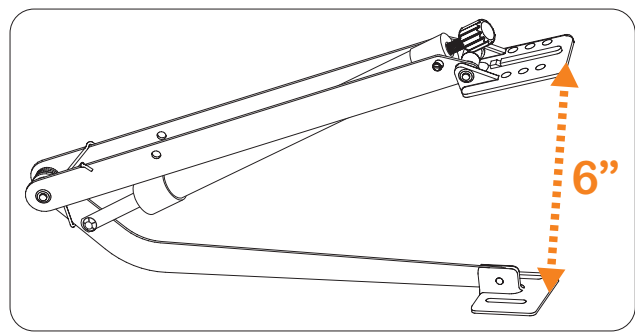
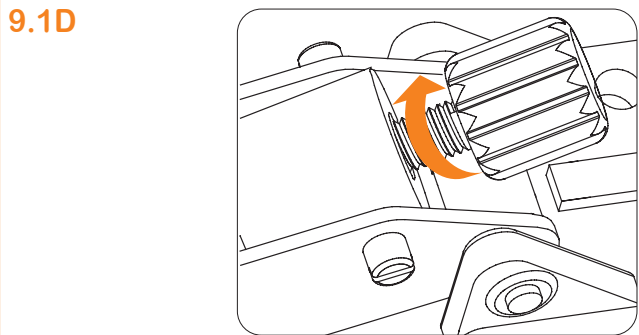
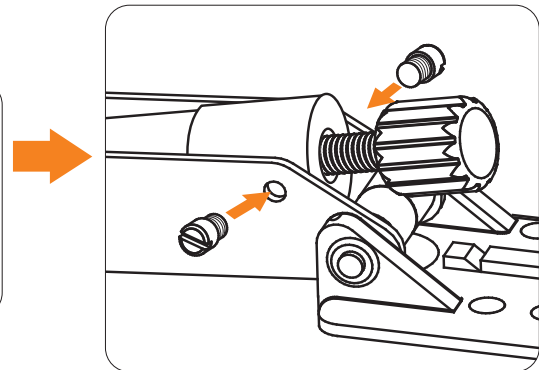
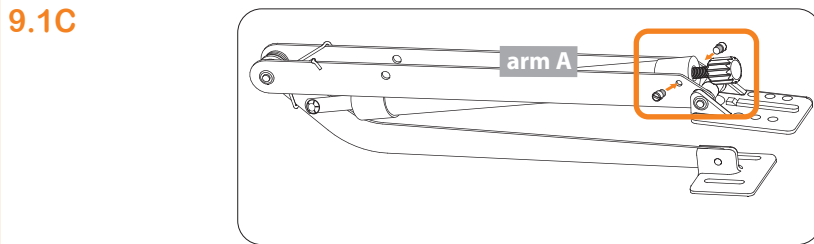

9.1E (9.1A - 9.1D) x 2

Handle	QTY	Cylinder	QTY	Adjusting Knob	QTY	Threaded Stud	QTY
	2		2		2		4

9.2A

V-3

VERSION B

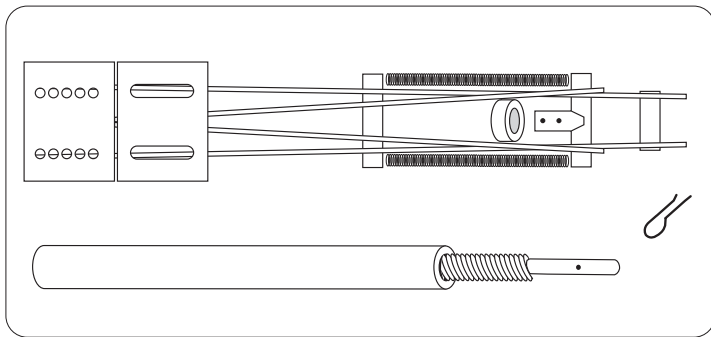

Scan This QR Code!
 To be taken to helpful
 Pro-tips, techniques,
 and assembly videos!
Reference #07

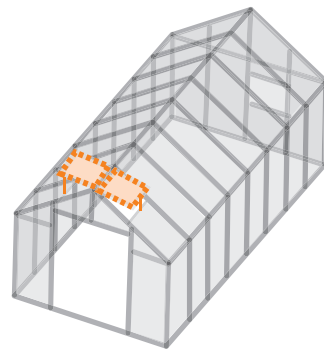

9.2B

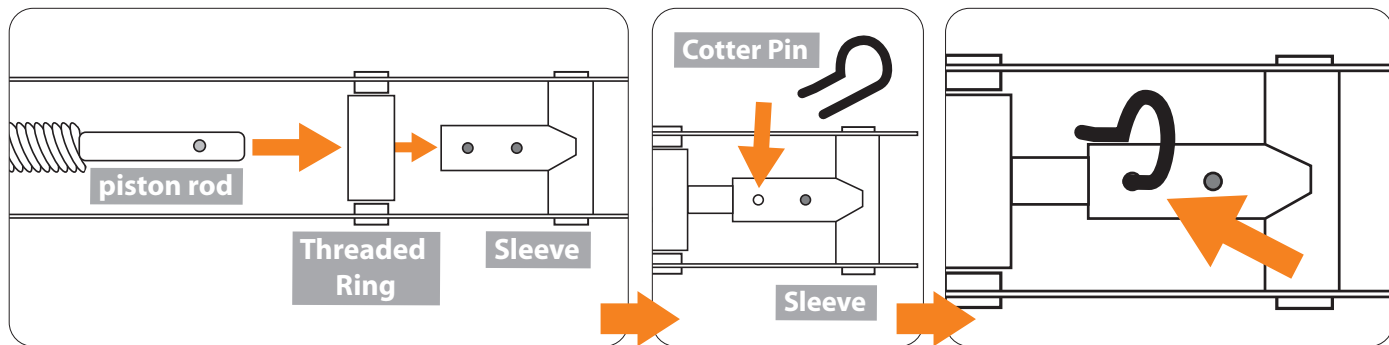

9.2C

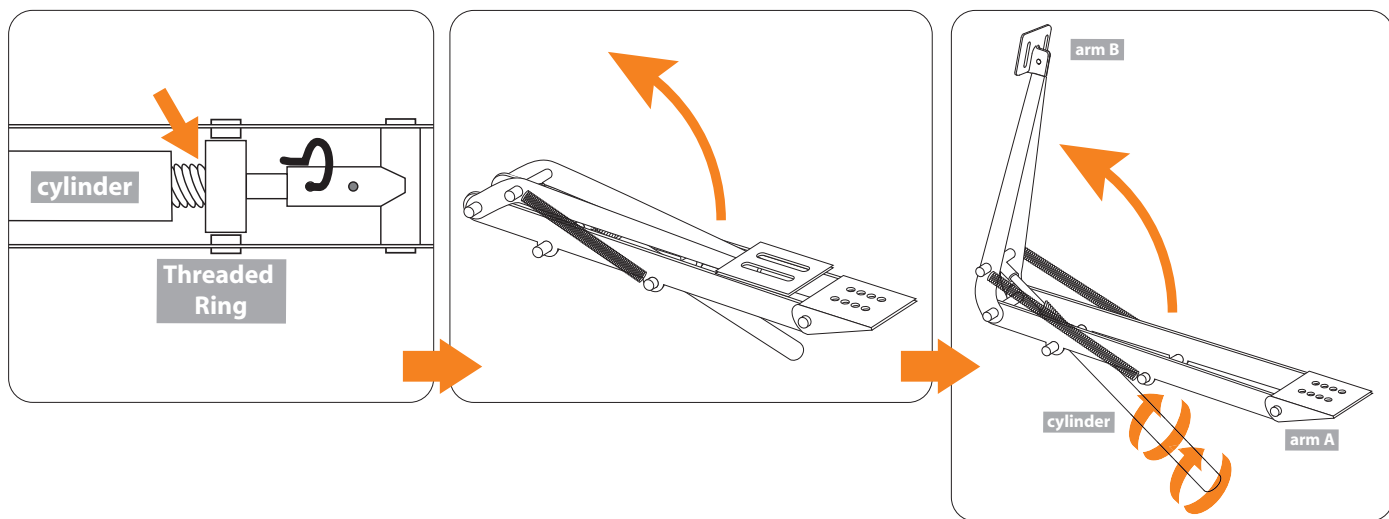

9.2D (9.2A - 9.2C) x 2

Handle B	QTY	Cylinder	QTY	Pin	QTY
	2		2		2

9.3A

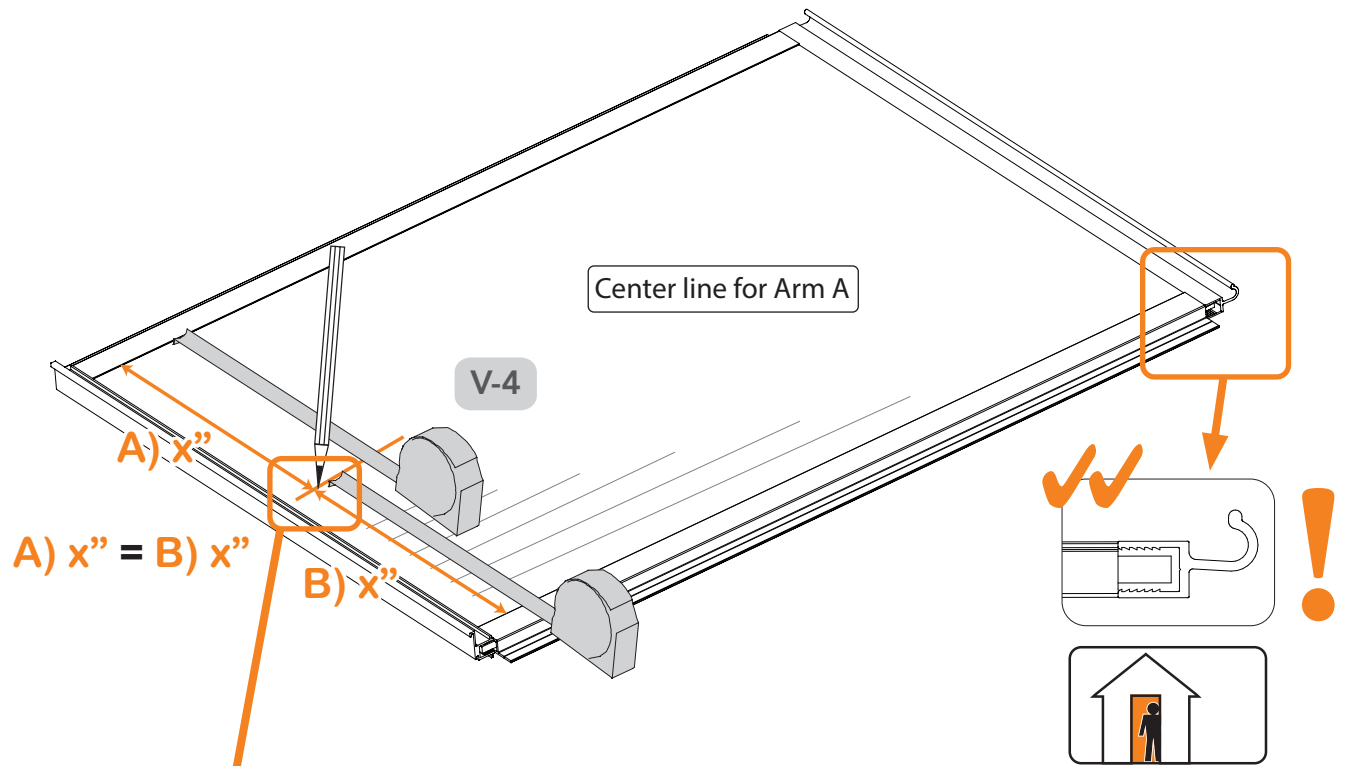

9.3B

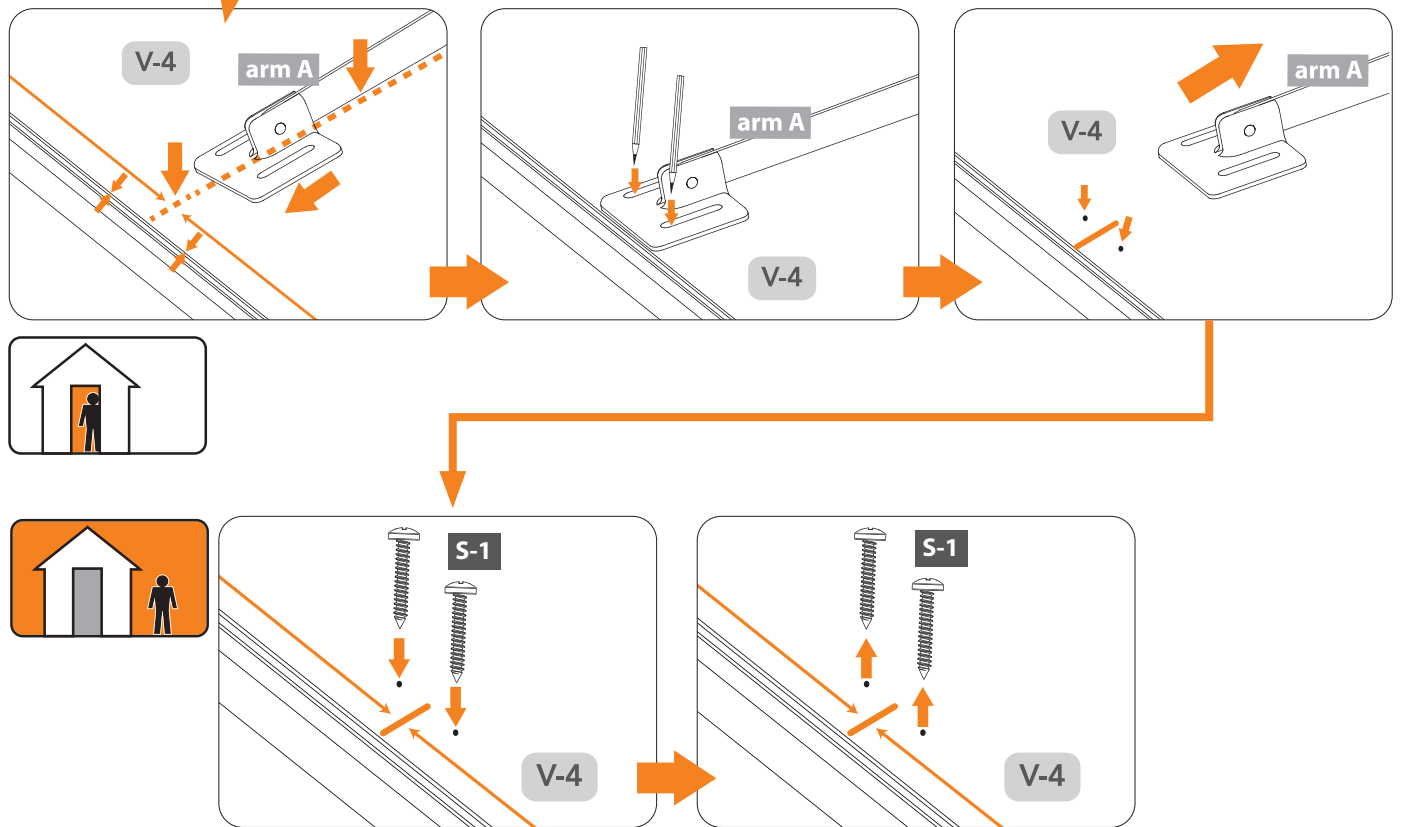

Factory Assembled Vent			QTY
	24" x 24 3/4"	V-4	2

9.3C

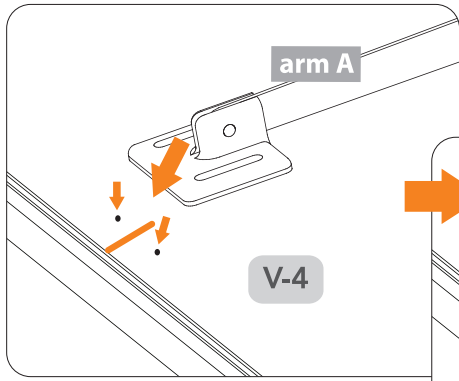

9.3D

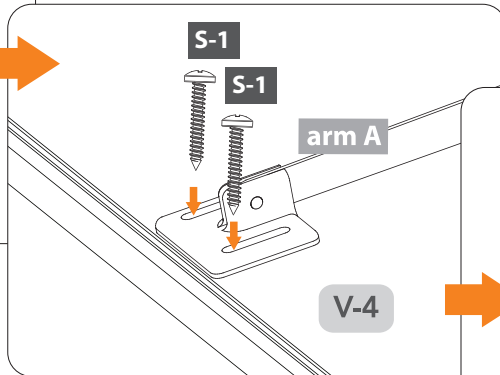

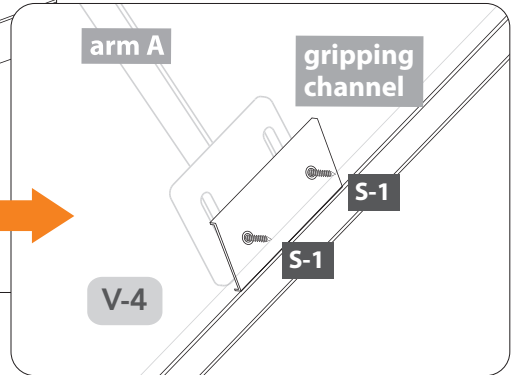

9.3E



9.3F (9.3A - 9.3E) x 2



Scan This QR Code!
To be taken to helpful
Pro-tips, techniques,
and assembly videos!
Reference #08

Connector	QTY	Gripping Channel	QTY
	S-1		2

9.4A

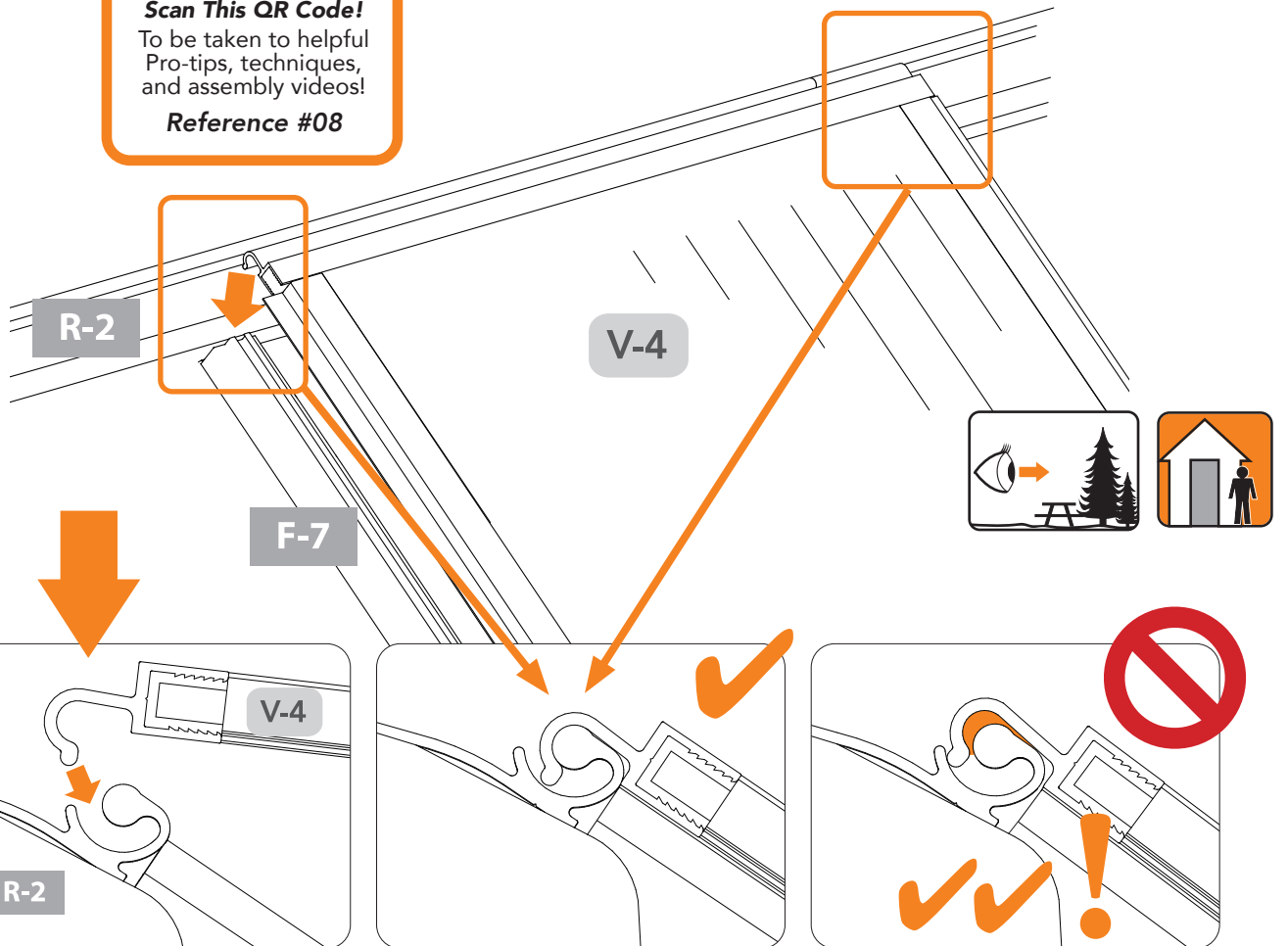

9.4B

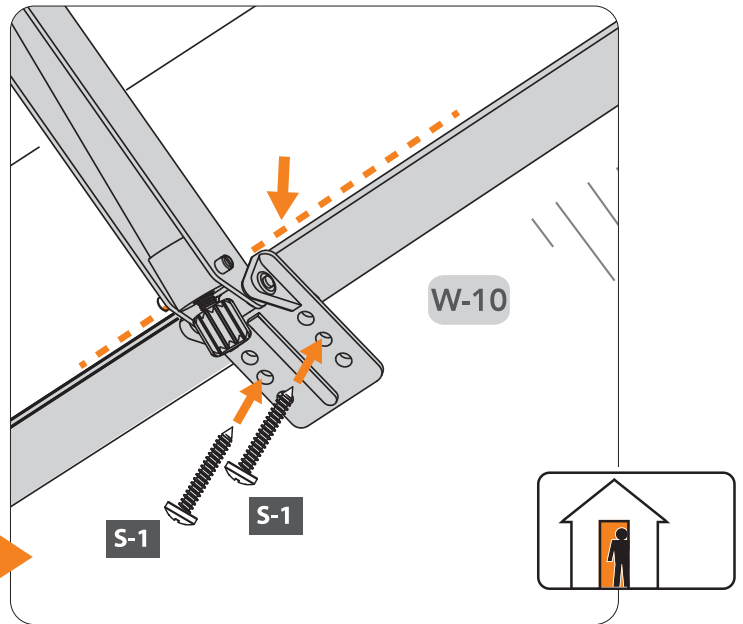
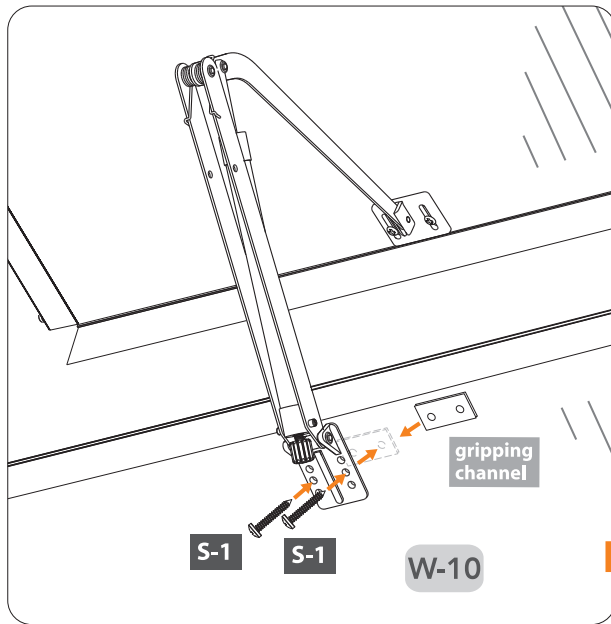

9.4C

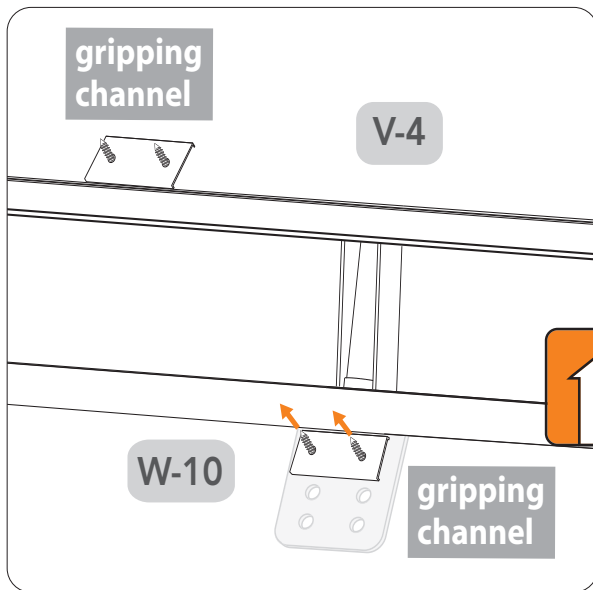

9.4D (9.4A - 9.4C) x 2

NOTE: Make sure **arm A** overlaps aluminum trim on **W-4**
REMARQUE: Assurez-vous que **le bras A** chevauche la garniture en aluminium sur **W-4**
NOTA: Asegúrese de que **el brazo A** se superponga a la moldura de aluminio en **W-4**

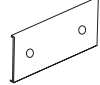
Connector	QTY	Gripping Channel	QTY
	S-1		2

9.5

x2

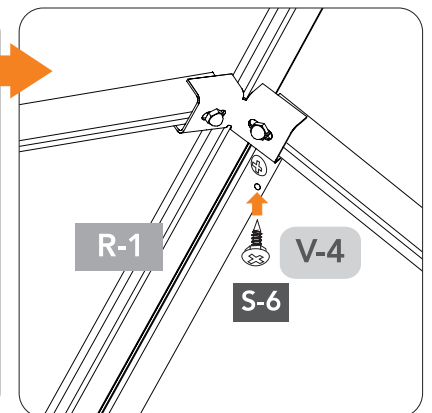
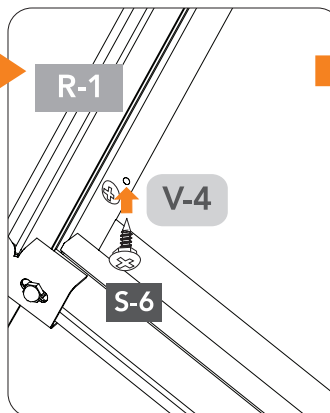
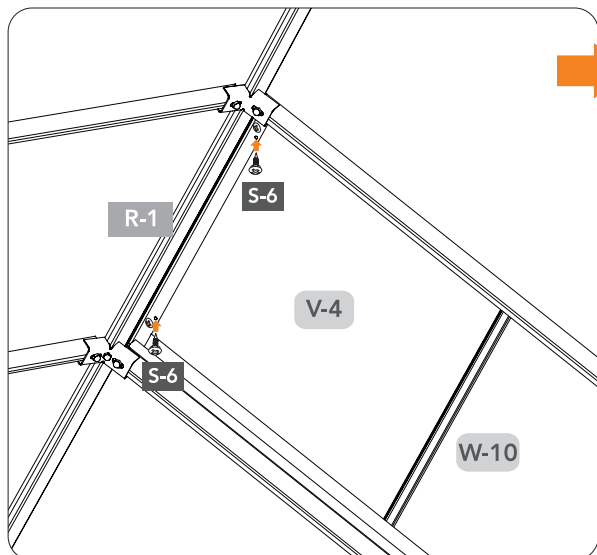

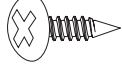
Connector	QTY
	S-6
	4

Install Pre-Assembled Doors

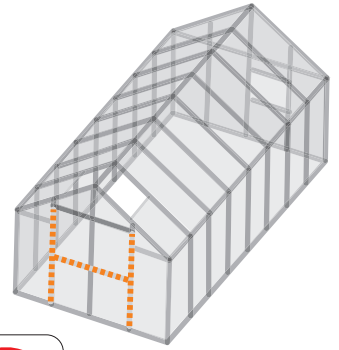
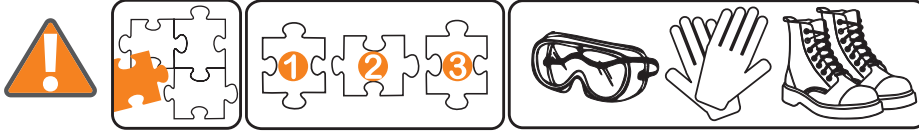

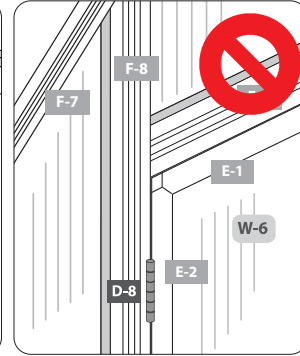
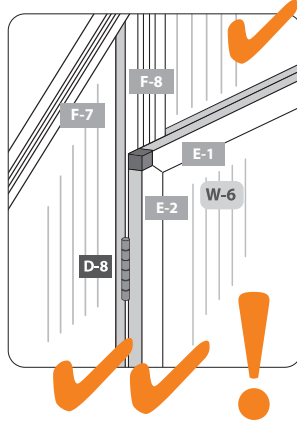
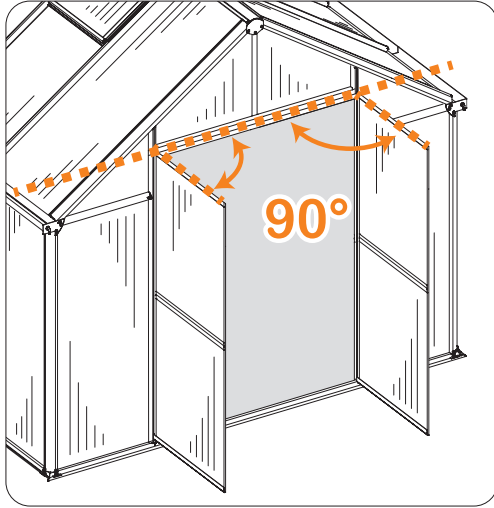

(10.1A - 10.3B) (see page 34)

10.4A

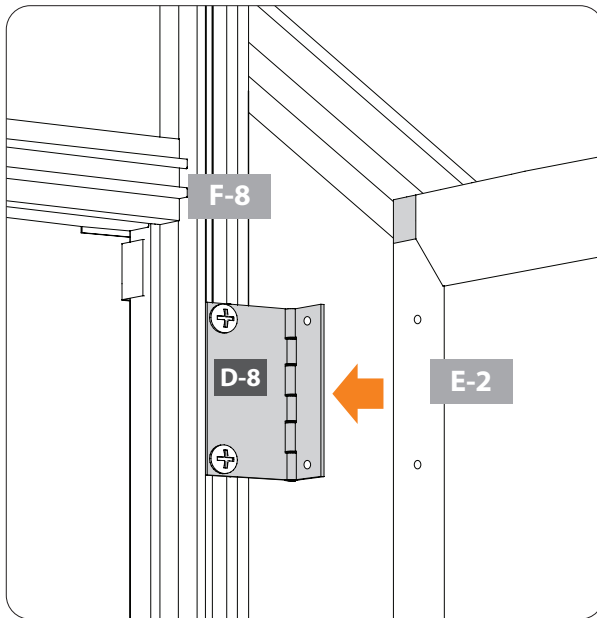

10.4B





Scan This QR Code!
To be taken to helpful Pro-tips, techniques, and assembly videos!
Reference #09



10.4C

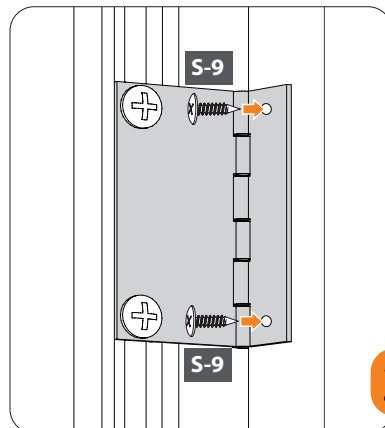

x4



Connector		QTY
	S-9	8

10.4D

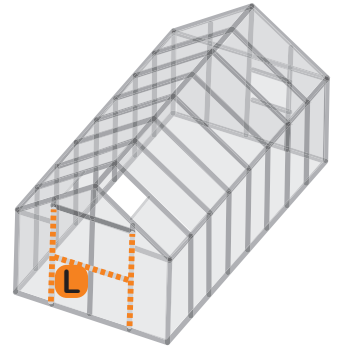
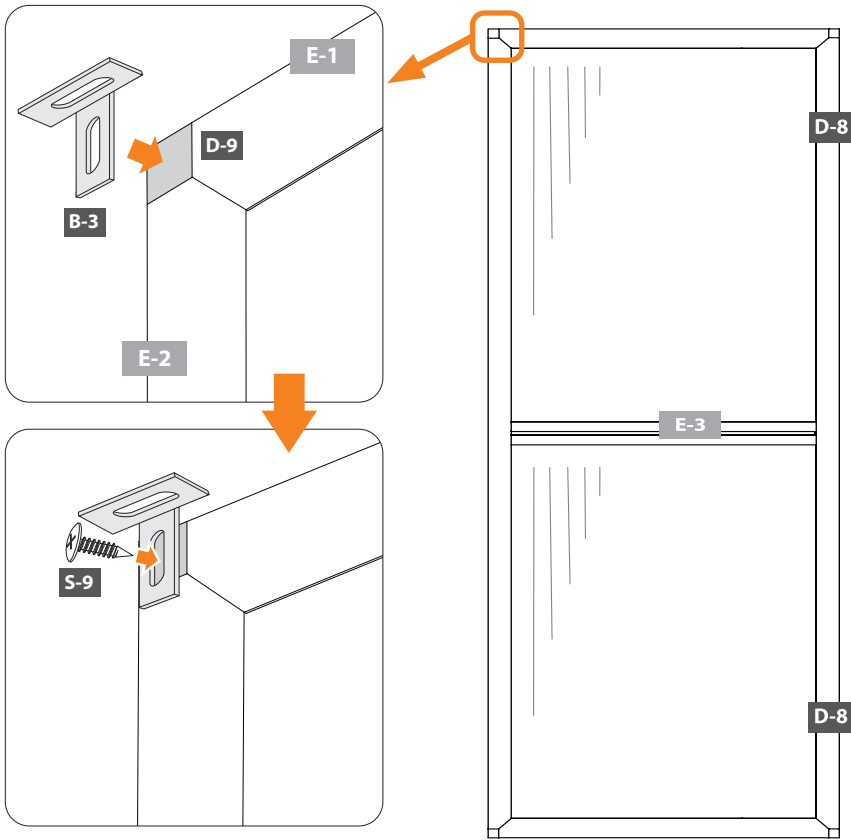

NOTE: Channel on E-3 indicates inside of door.
REMARQUE: le canal sur E-3 indique l'intérieur de la porte.
NOTA: El canal en E-3 indica el interior de la puerta.

10.4E

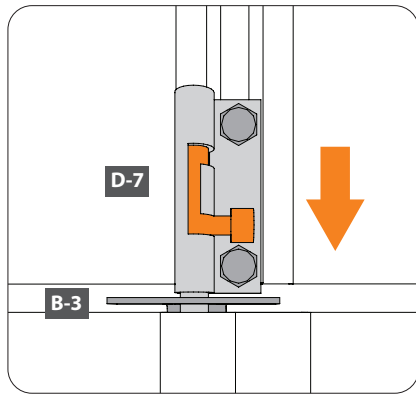

Connectors		QTY
	B-3	1
	S-9	1

10.5

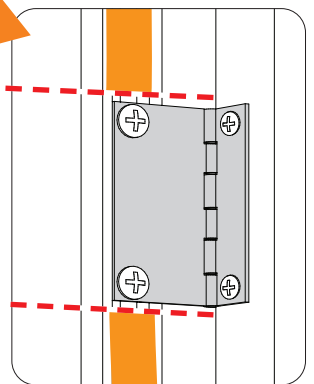
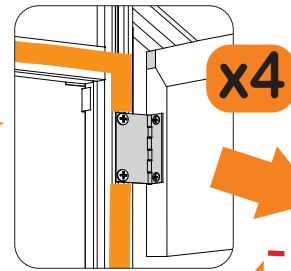
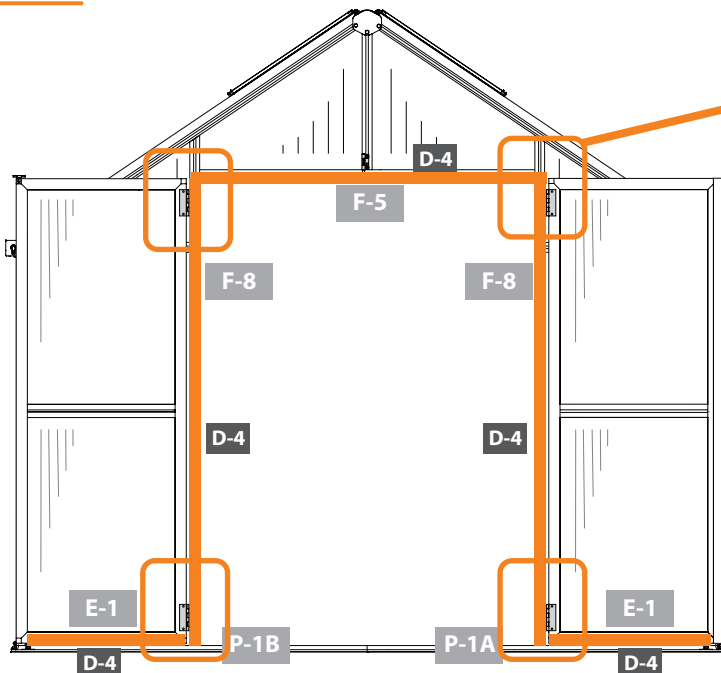

Connector		QTY
	D-4	20'

10.6A

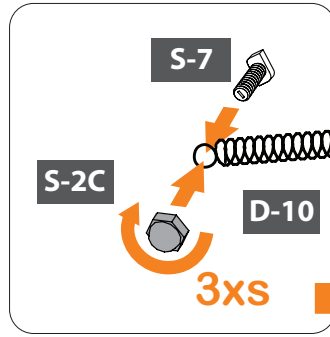
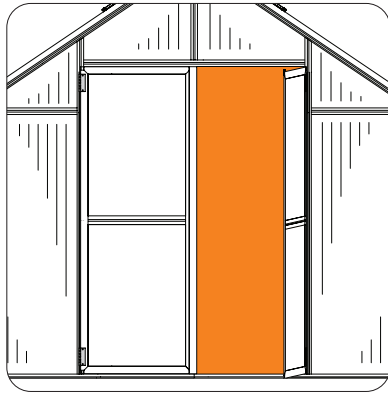

10.6B

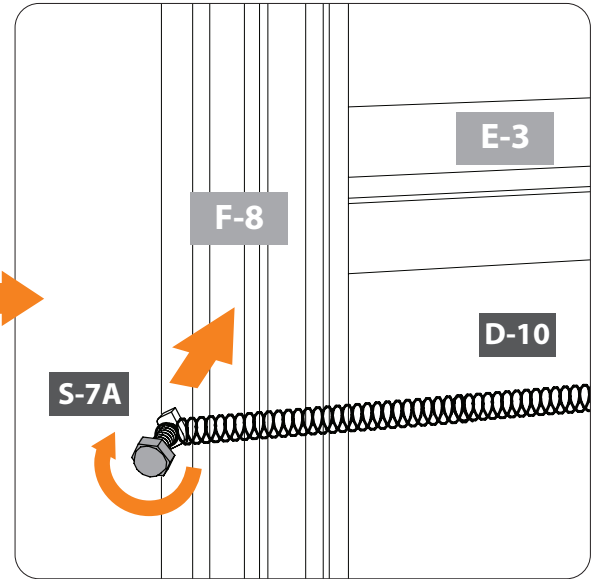

10.6C

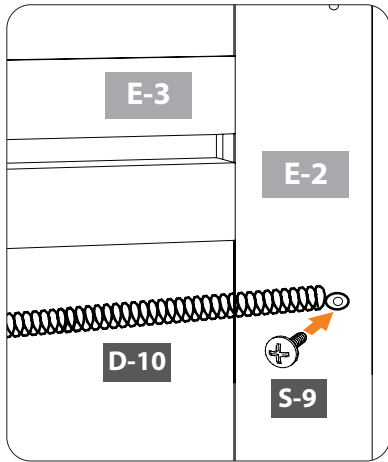

10.6D

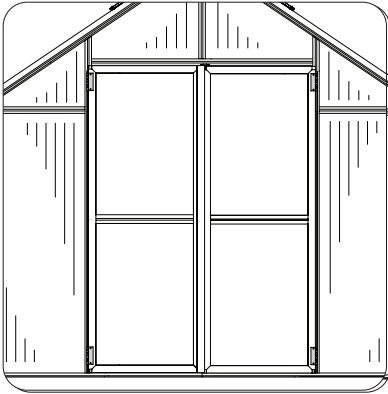

10.6E

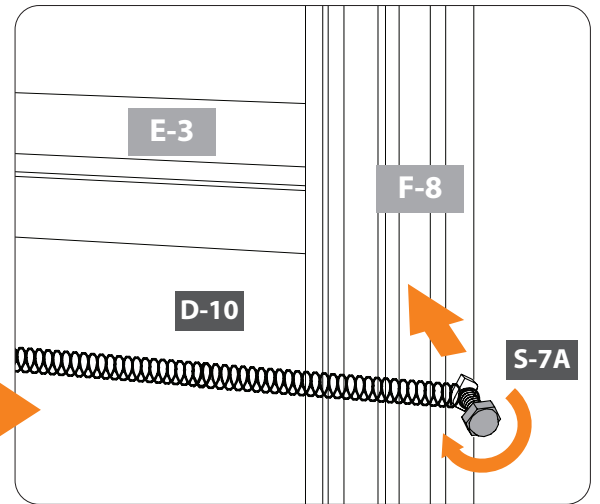
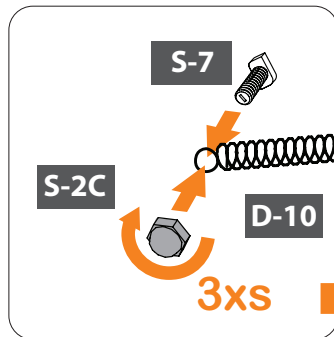

10.6F

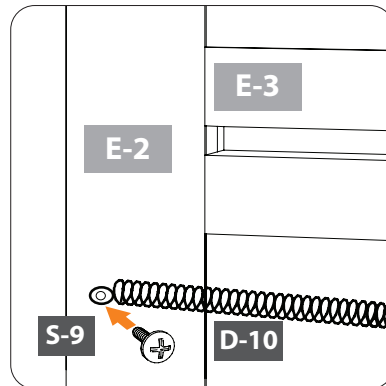
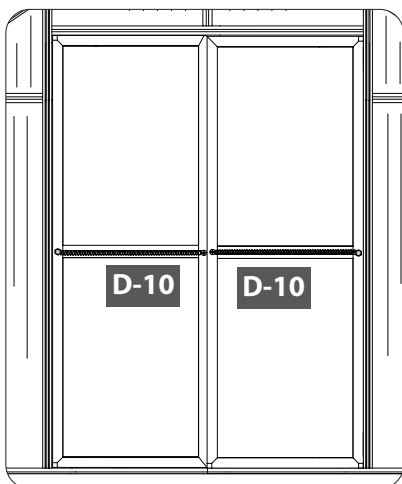

Connectors		QTY	Connectors		QTY
	D-10	2		S-2C	2
	S-9	2		S-7	2

Secure to Platform

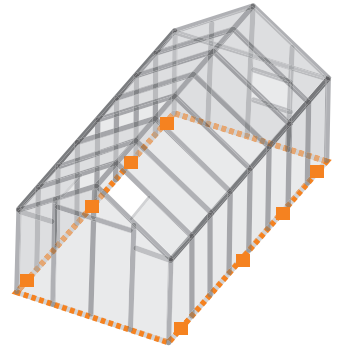
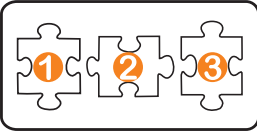

11.1



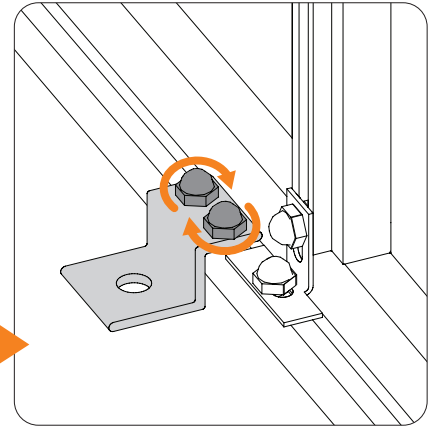
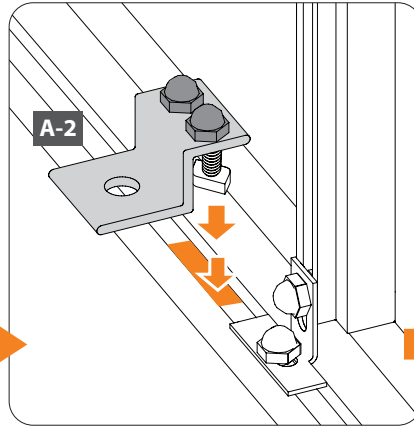
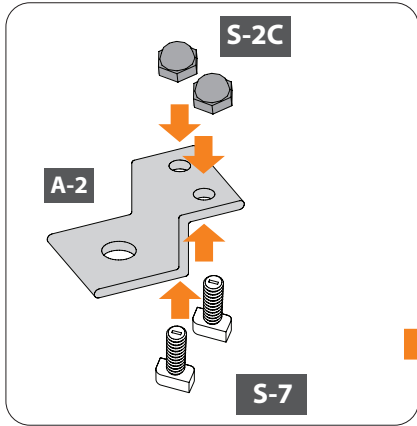

x8

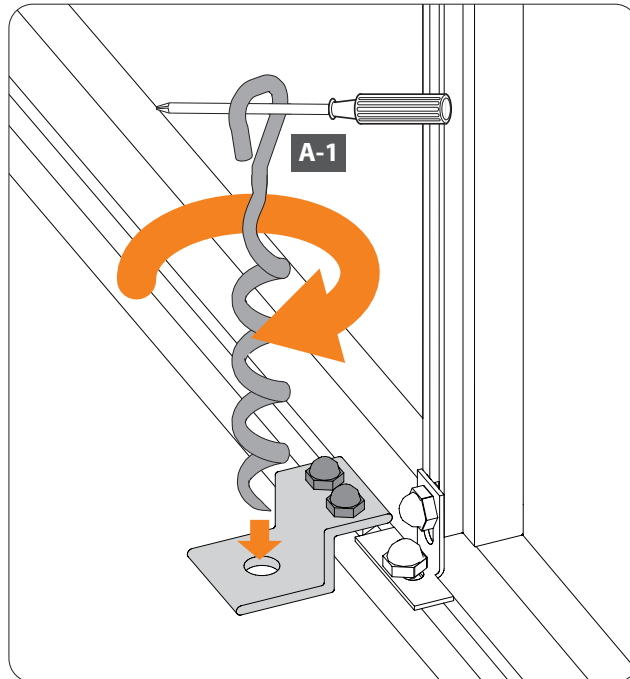

11.2

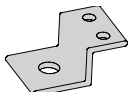
x8



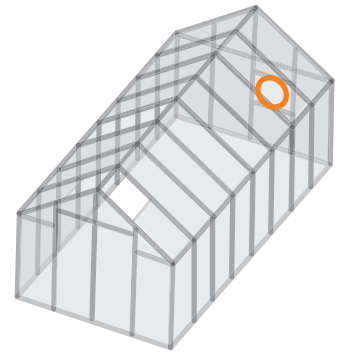
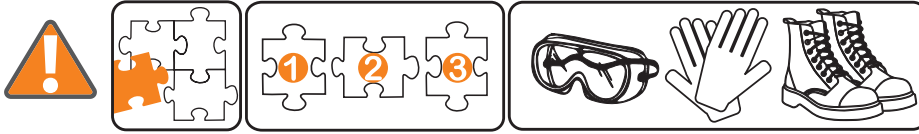

Bracket		QTY	Ground Anchor		QTY	Connectors		QTY
	A-2	8		A-1	8		S-2C	16
							S-7	16

Install Fan and Solar Panel

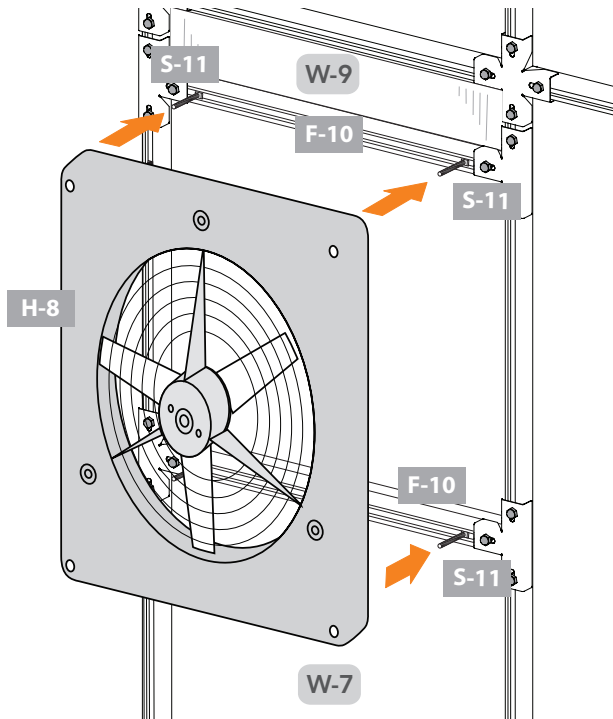

12.1A





Scan This QR Code!
To be taken to helpful Pro-tips, techniques, and assembly videos!
Reference #11

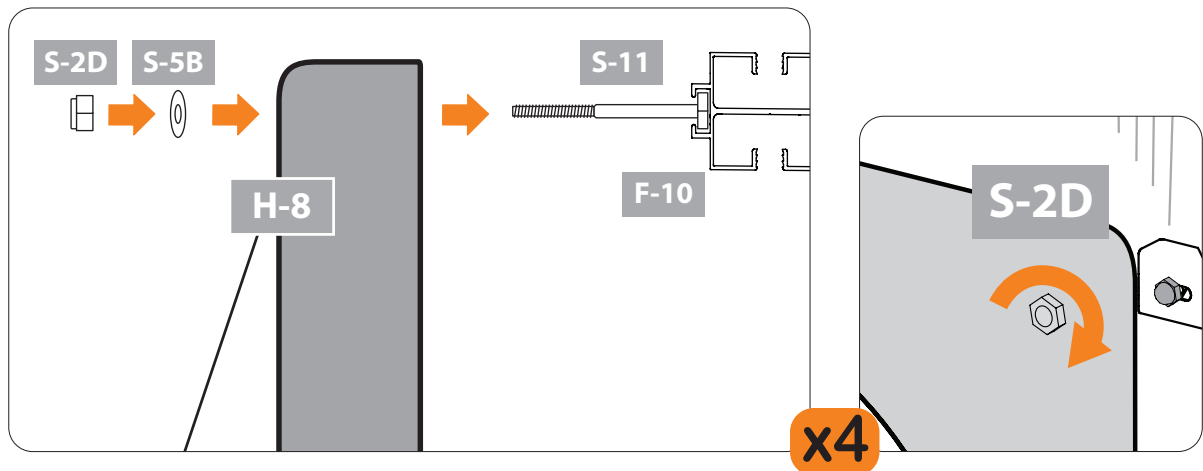

12.1B

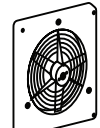

Connectors		QTY	Fan	QTY	
	S-2D	4		H-8	1
	S-5B	4			

12.2A

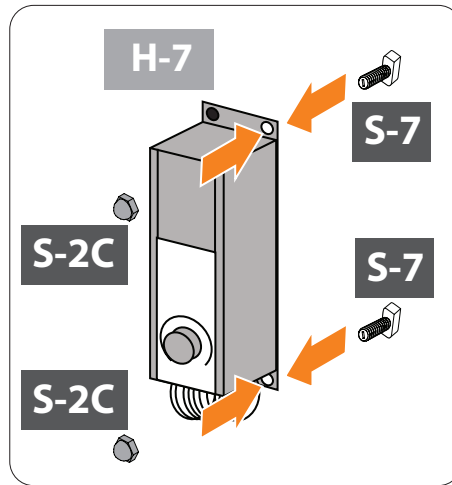
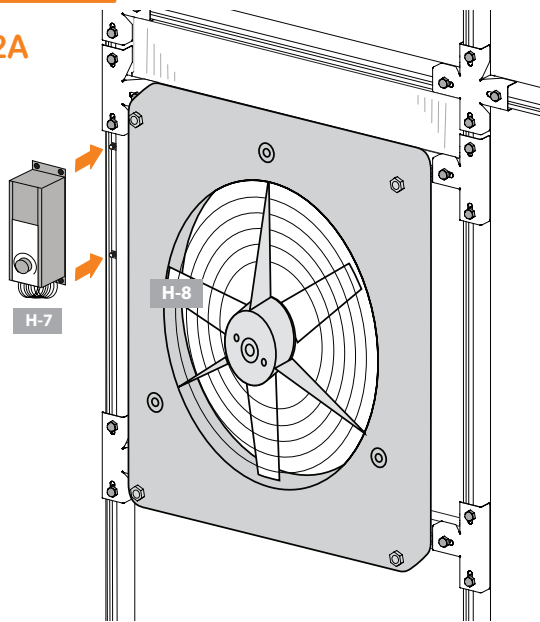

12.2B

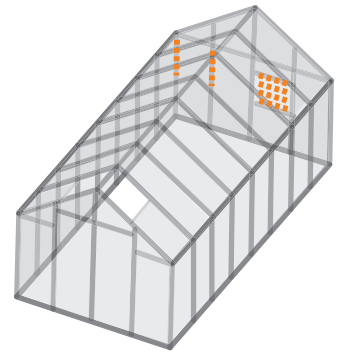

12.2C

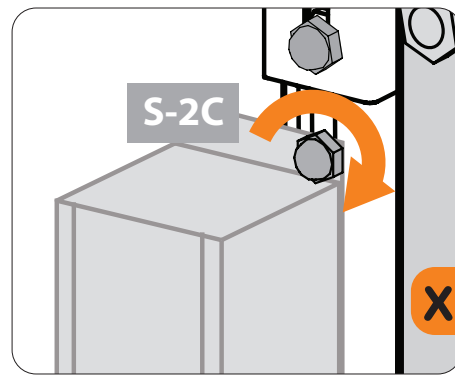
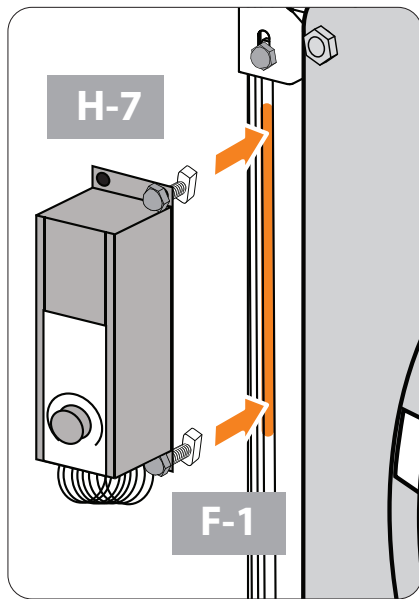

12.2D

x2

Connectors		QTY	Thermostat		QTY
	S-7	2		H-7	1
	S-2C	2			

12.3A

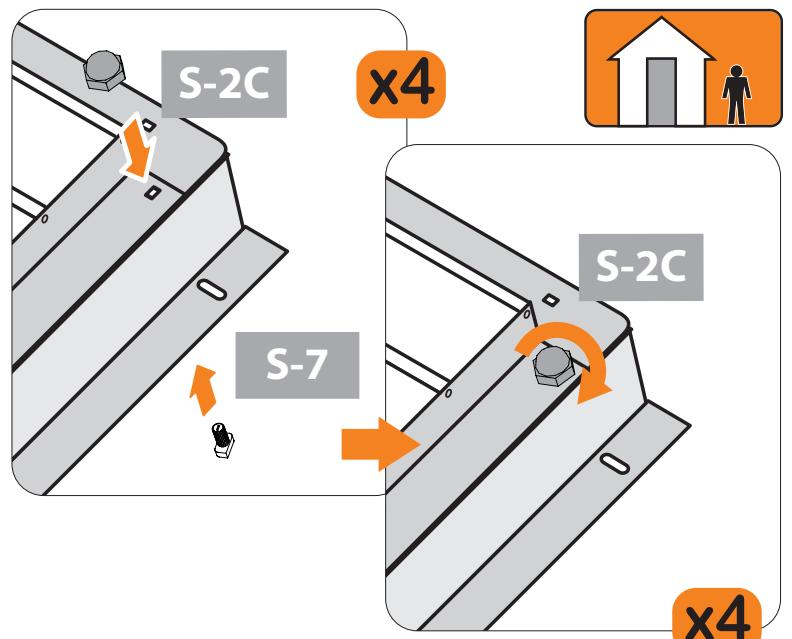
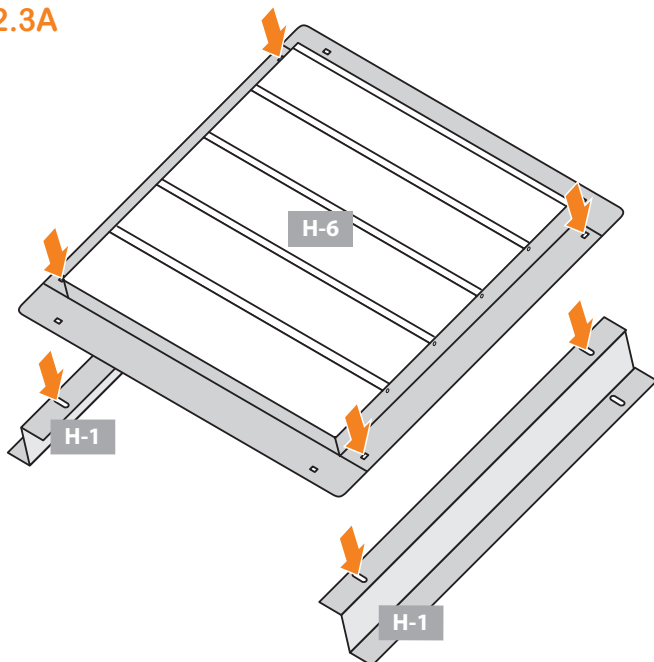

x4

x4

12.3B

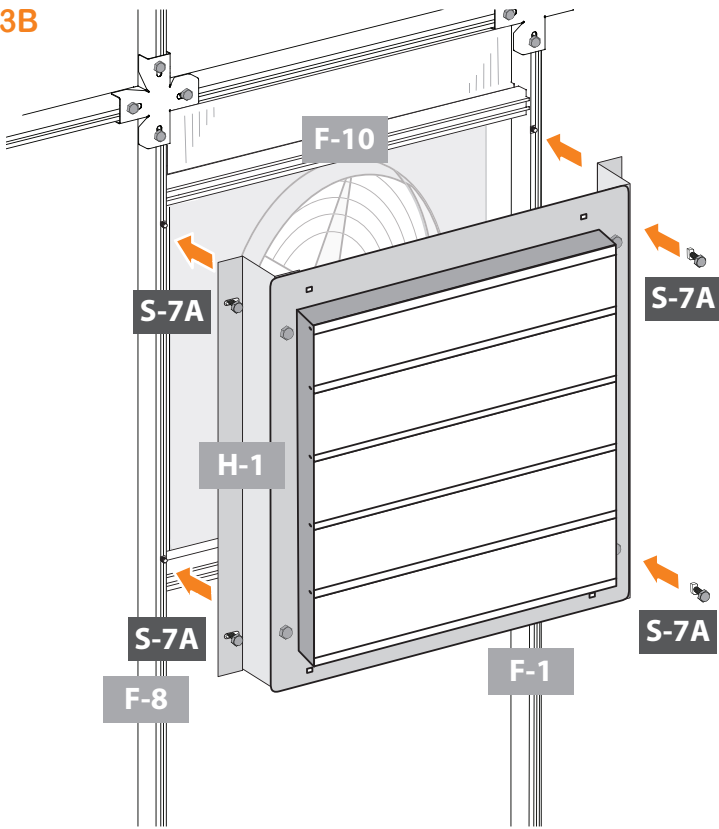

12.3C

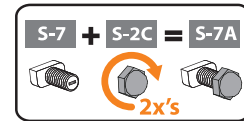
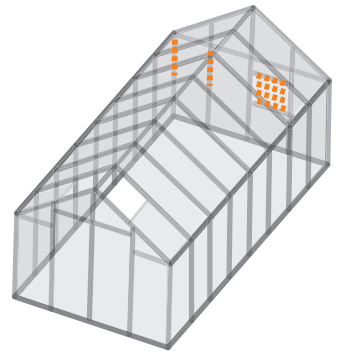
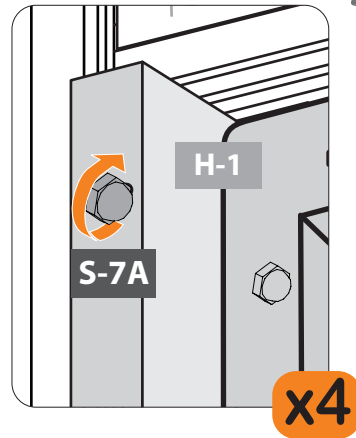

12.3D

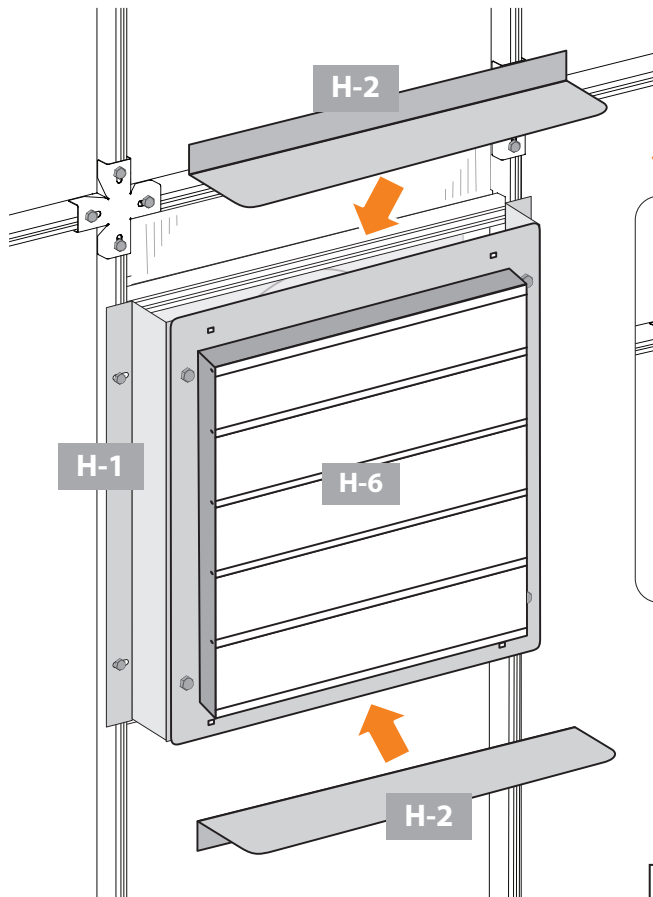

12.3E

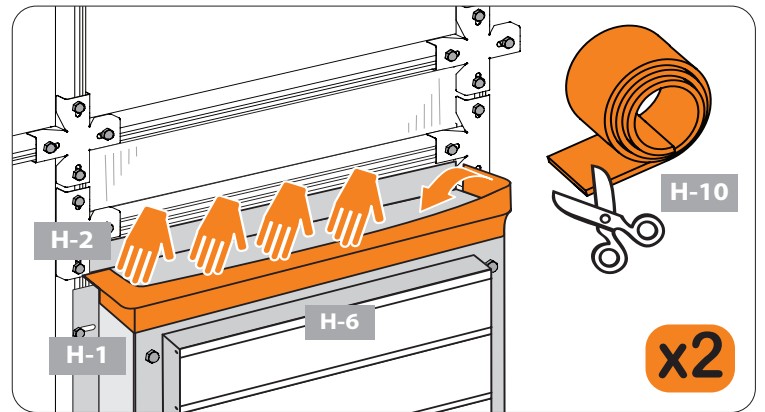

Shutter	H-6	QTY	Tape	H-10	QTY
	H-6	1		H-10	10'

Connectors		QTY	Shutter Parts		QTY
	S-7	8		H-2	2
	S-2C	8		H-1	2

12.4A

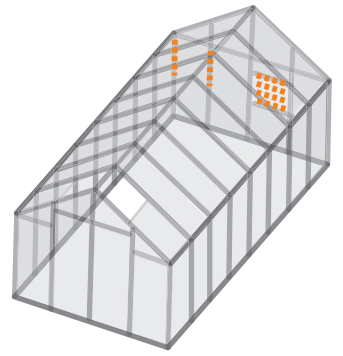
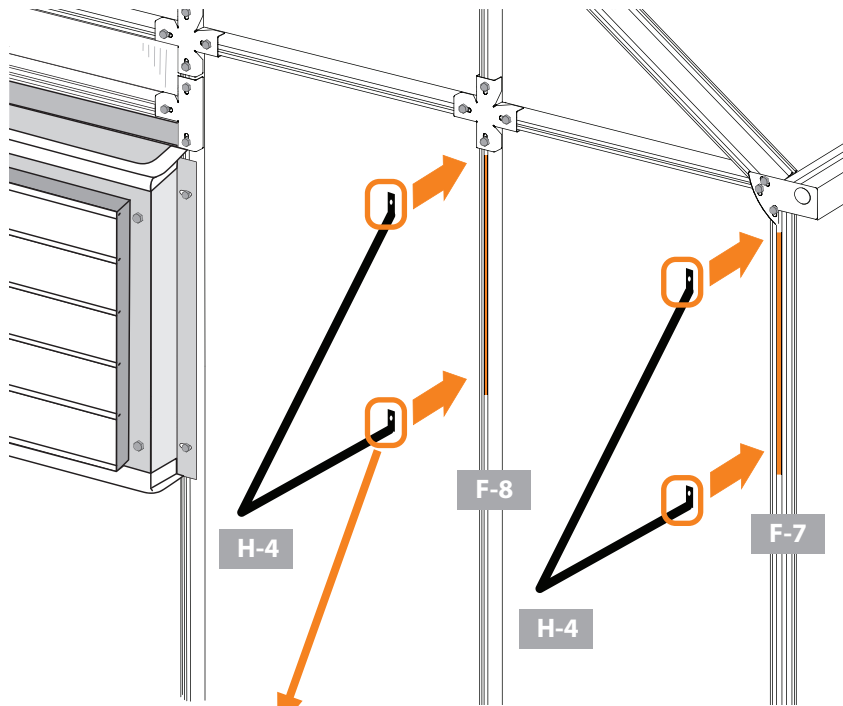

12.4B

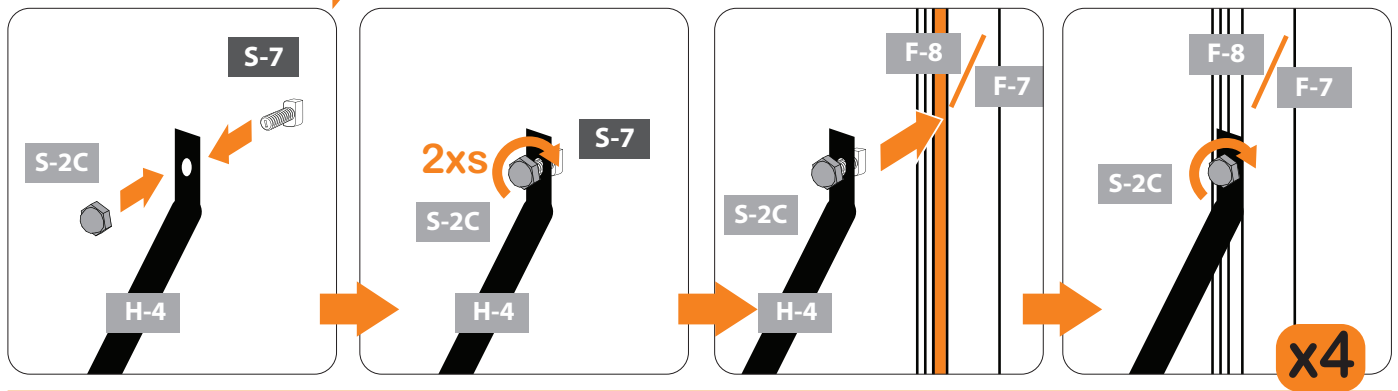

12.4C

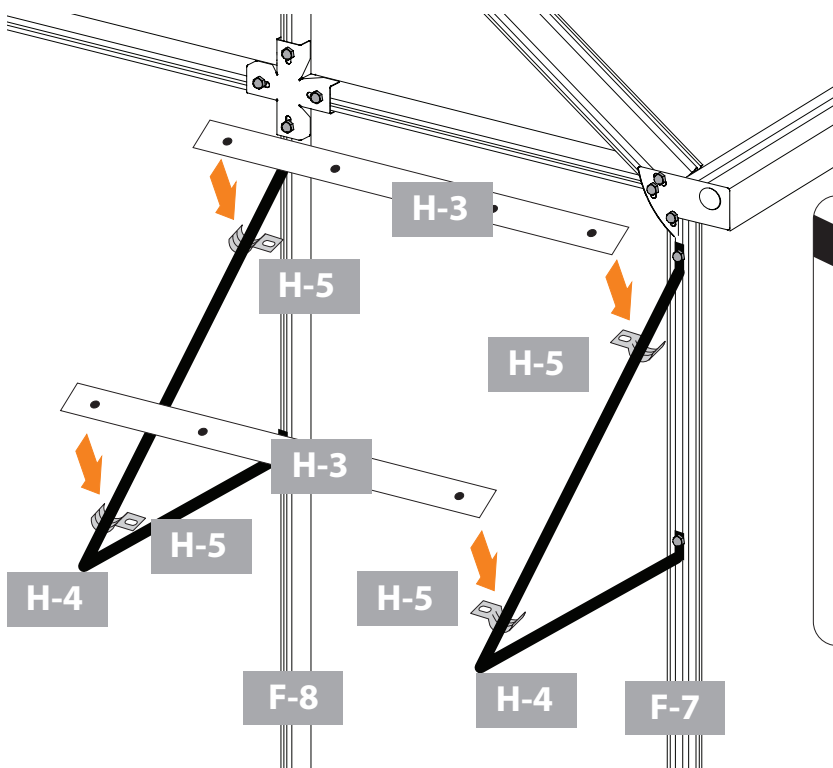

12.4D

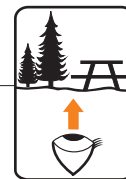
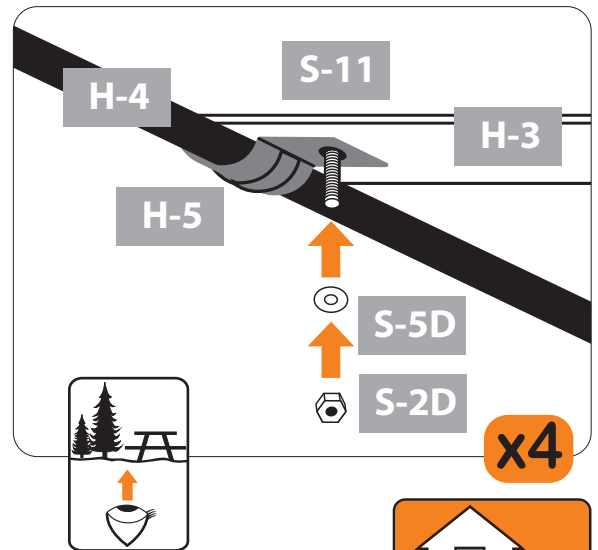

12.4E

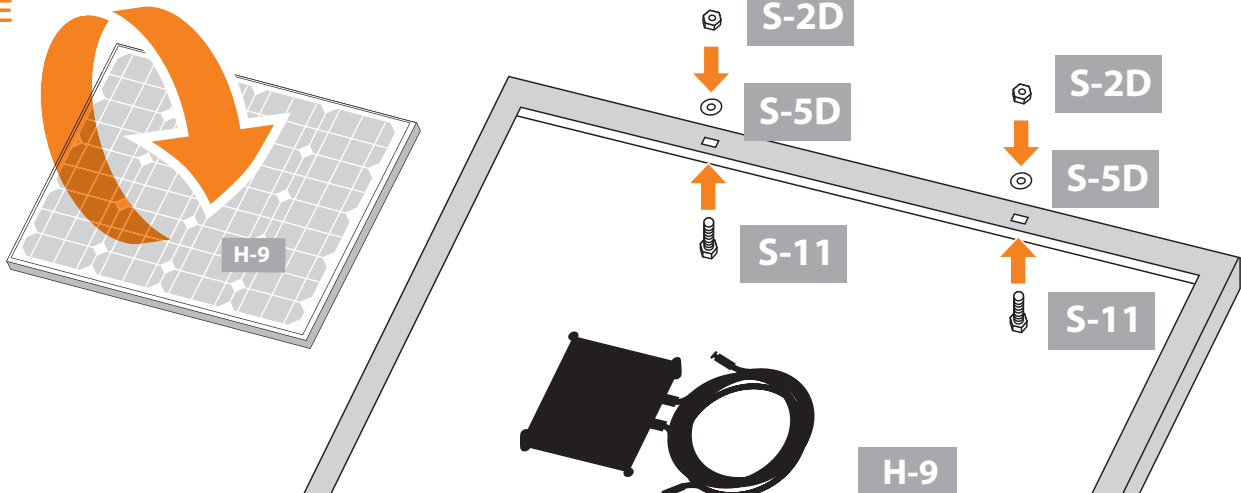

12.4F

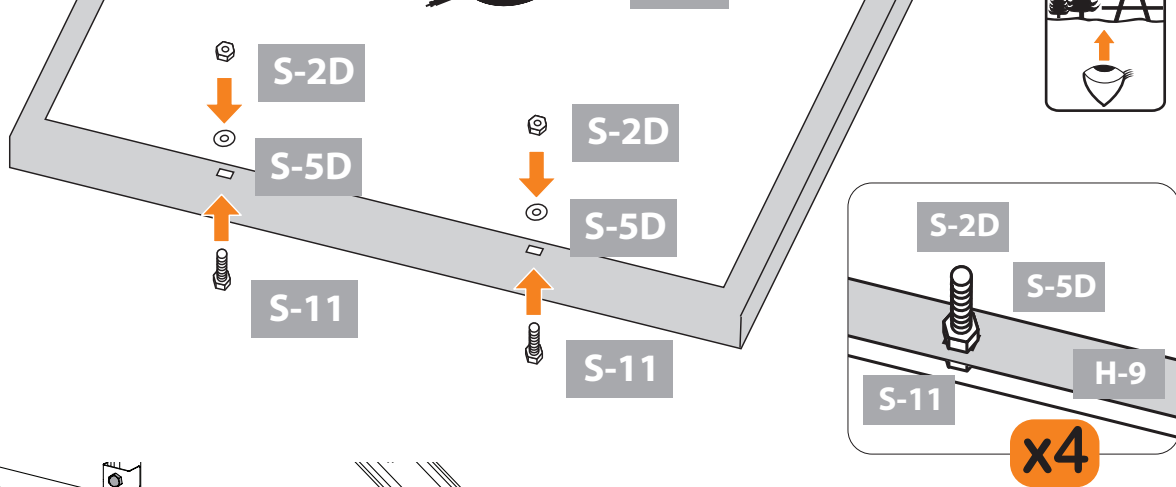

12.4G

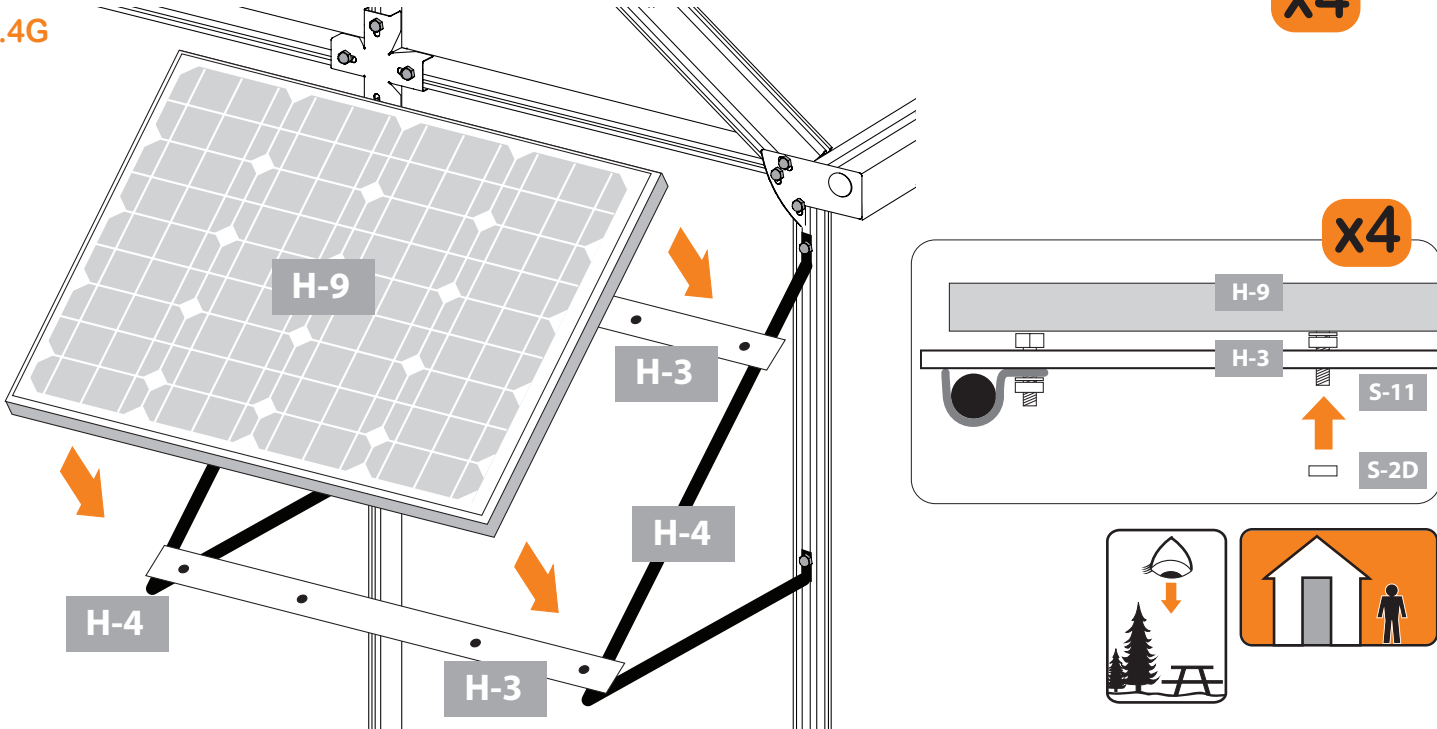

Connectors

Connectors	QTY	Solar Panel	QTY
	H-5	4	

Solar Panel Parts

Solar Panel Parts	QTY
	H-4
	H-3

Connectors	QTY
	S-11
	S-5D
	S-2D
	S-7
	S-2C

12.5A

Working from inside. Drill hole through polycarbonate.

Travailler de l'intérieur. Percez un trou dans le polycarbonate.

Trabajando desde adentro. Taladre un agujero a través del policarbonato.

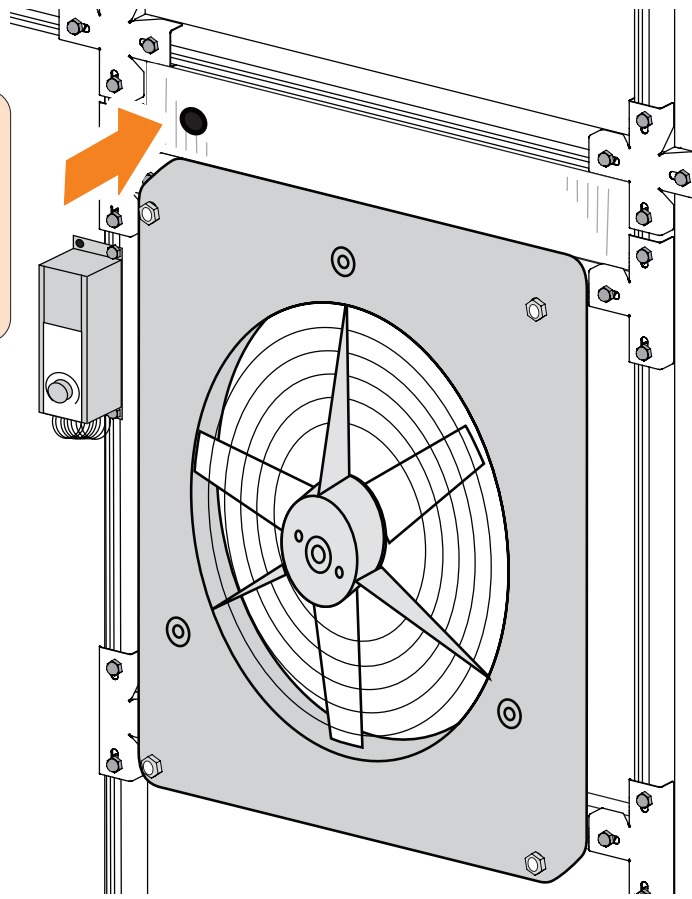

12.5B

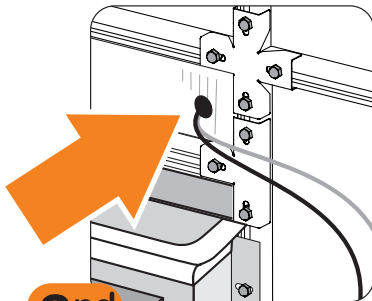

2nd

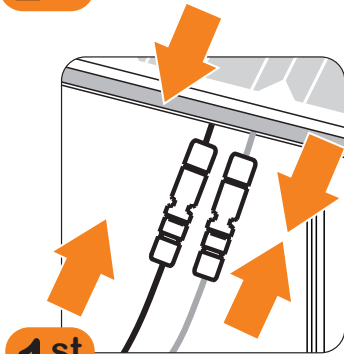

1st

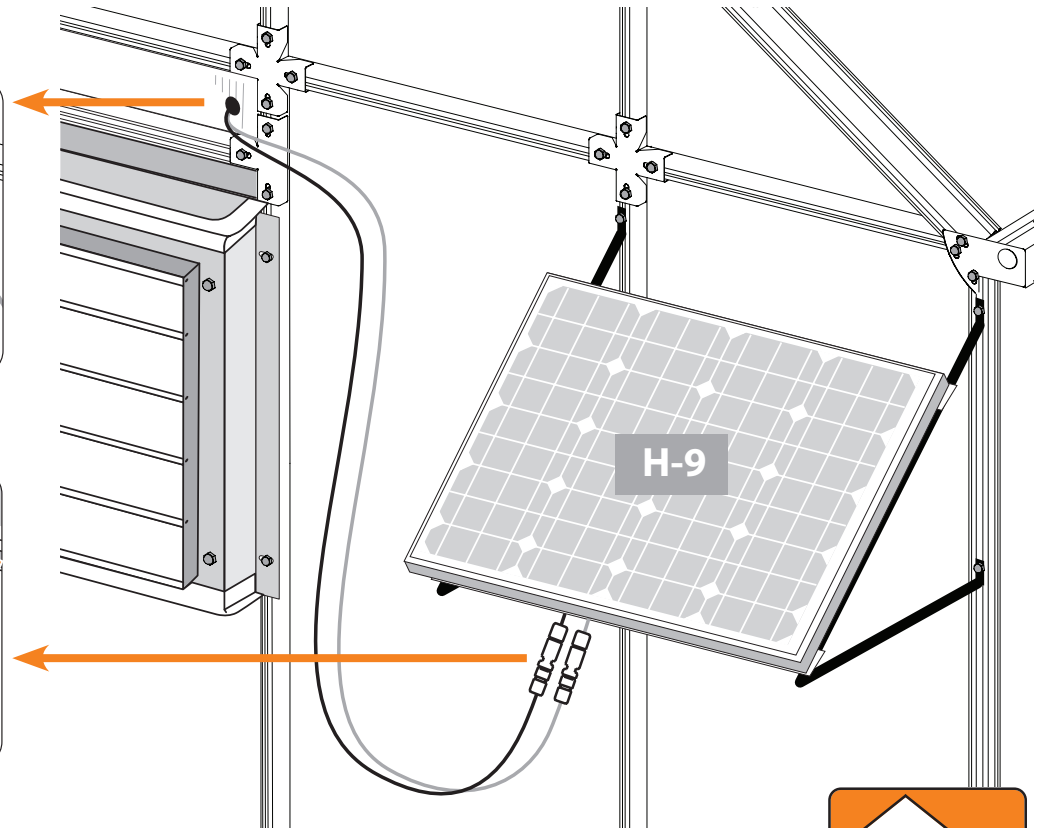

12.5C

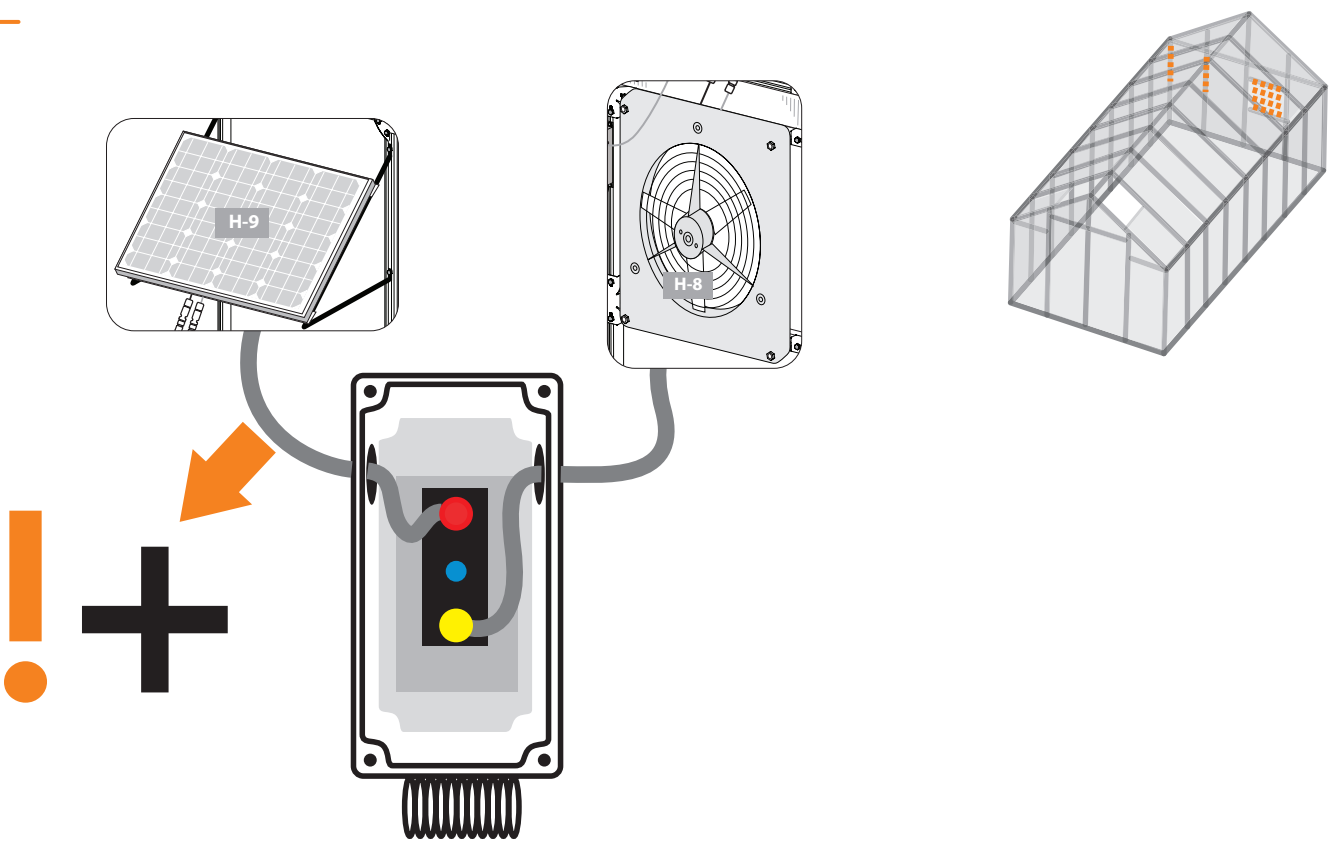

12.5D

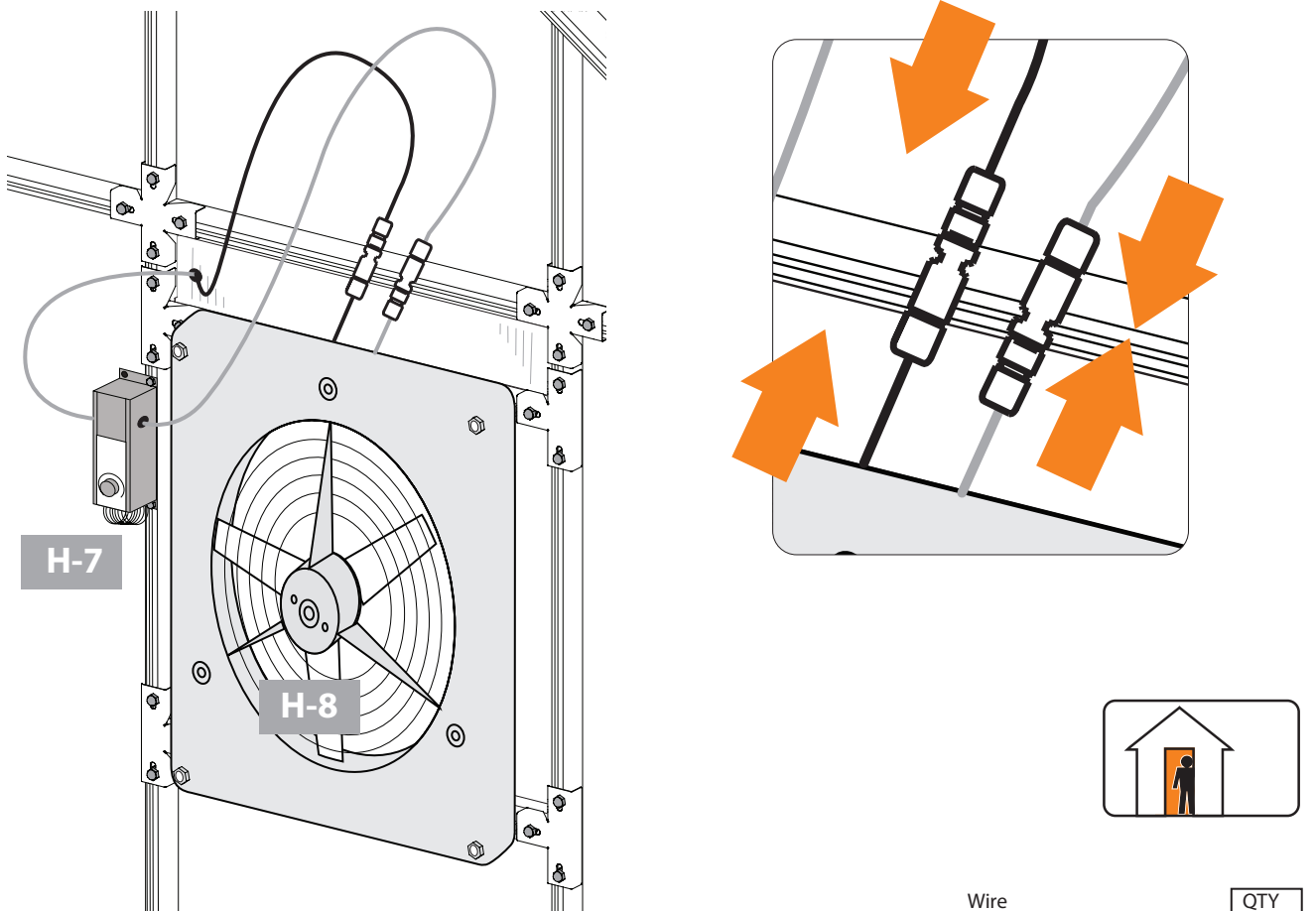

Wire		QTY
	H-11	16'

12.6

OPTIONAL CHARGE CONTROLLER AND BATTERY: For accurate wiring using charge controller and battery, refer to the wiring diagram provided with the charge controller.

CONTRÔLEUR DE CHARGE ET BATTERIE EN OPTION : Pour un câblage précis à l'aide du contrôleur de charge et de la batterie, reportez-vous au schéma de câblage fourni avec le contrôleur de charge.

CONTROLADOR DE CARGA Y BATERÍA OPCIONALES: Para un cableado preciso usando el controlador de carga y la batería, consulte el diagrama de cableado provisto con el controlador de carga.

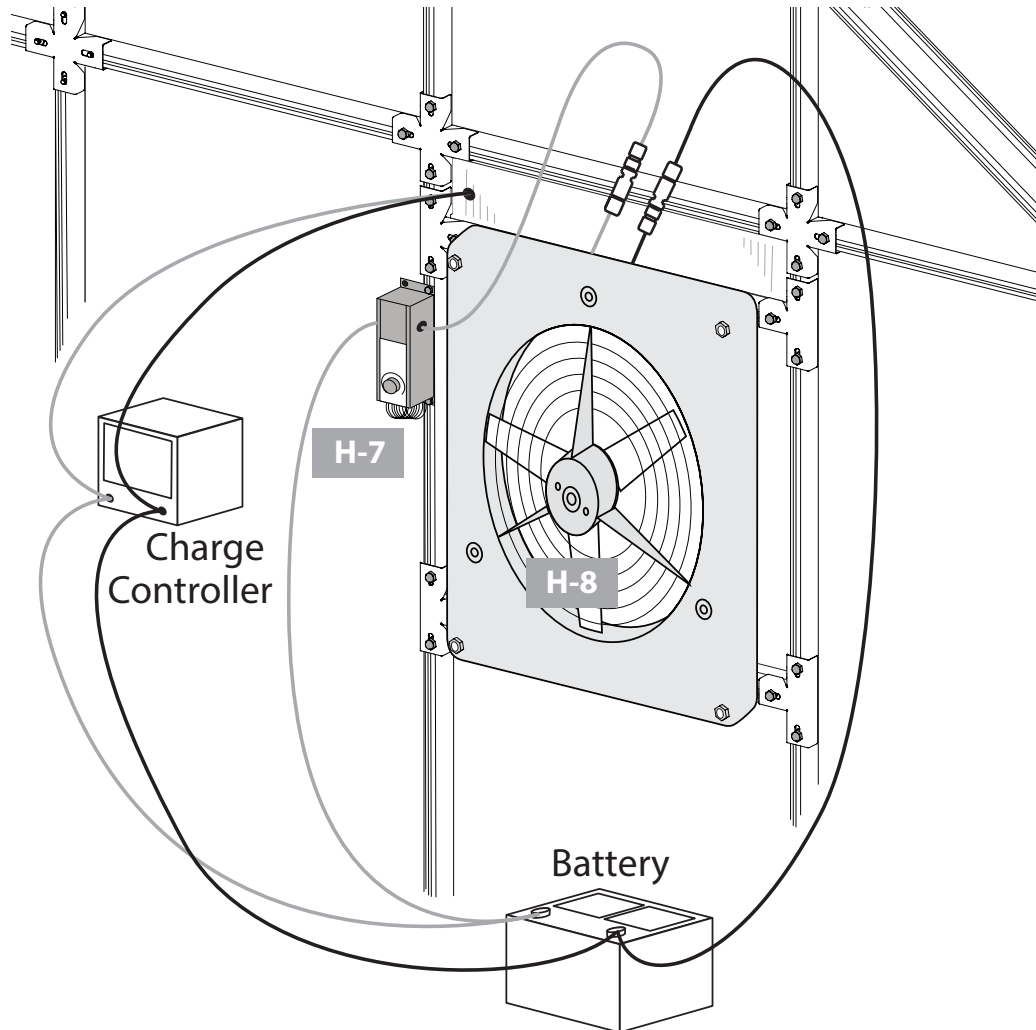
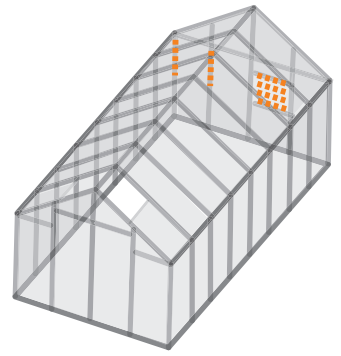

NOTE: Due to liability we do not sell or ship battery systems with charge controllers. They can easily be purchased locally. Customer would need a 6amp charge controller which helps to limit the power going into the battery and prevents the battery from overheating. Any standard 12 volt marine or deep cycle battery would do.

REMARQUE: En raison de notre responsabilité, nous ne vendons ni n'expédions de systèmes de batterie avec contrôleurs de charge. Ils peuvent facilement être achetés localement. Le client aurait besoin d'un contrôleur de charge de 6 ampères qui aide à limiter la puissance entrant dans la batterie et empêche la batterie de surchauffer. N'importe quelle batterie marine ou à cycle profond standard de 12 volts ferait l'affaire.

NOTA: Debido a responsabilidad, no vendemos ni enviamos sistemas de batería con controladores de carga. Se pueden comprar fácilmente localmente. El cliente necesitaría un controlador de carga de 6 amperios que ayuda a limitar la energía que ingresa a la batería y evita que la batería se sobrecaliente. Cualquier batería estándar marina o de ciclo profundo de 12 voltios serviría.