

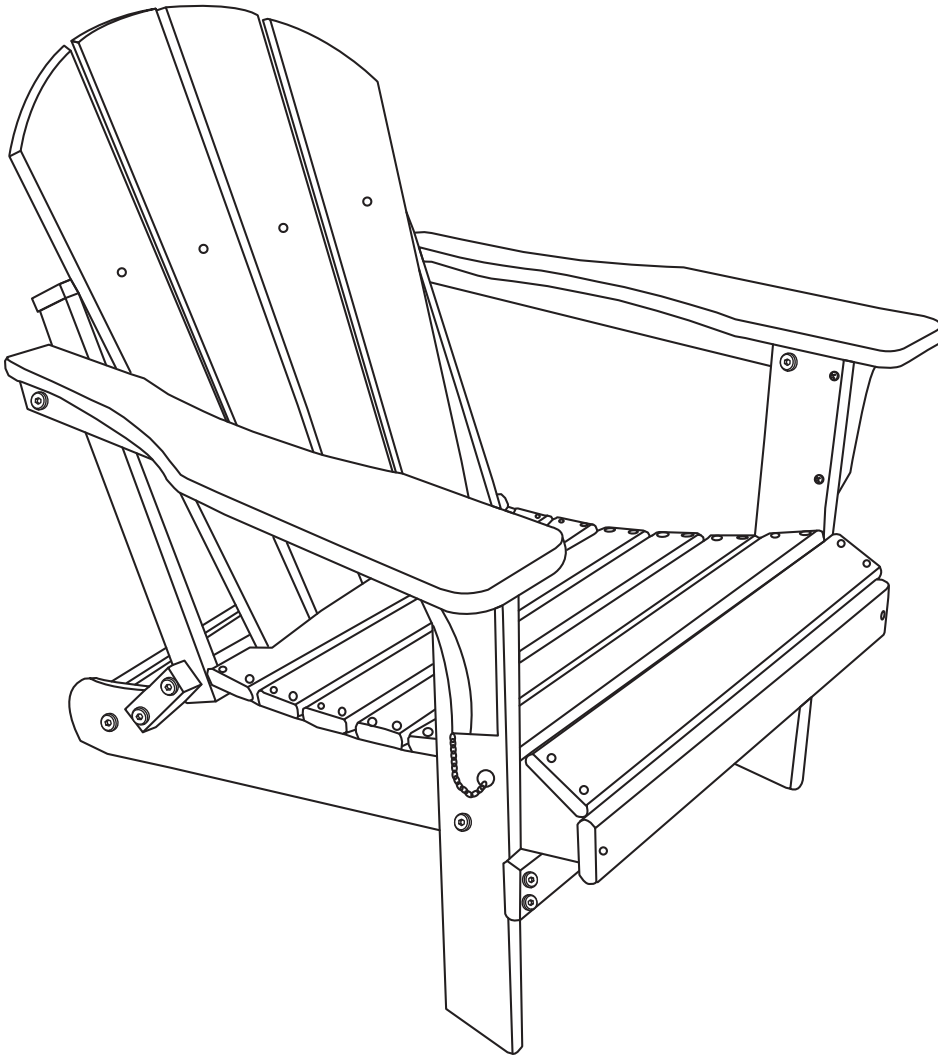

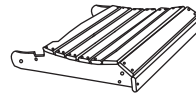

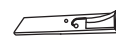

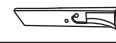



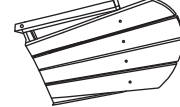

FOLDABLE ADIRONDACK CHAIR

Read all assembly and care instructions carefully before using this product. Save this manual for future reference.
Assemble components on a soft, clean surface to avoid scratching or damaging the finish.



Inspect packaging to ensure all parts are accounted for before disposing of packing materials.

No.	PARTS	QTY.
A	 Seat	1
B	 Right Leg	1
C	 Left Leg	1
D	 Right Armrest	1
E	 Left Armrest	1
F	 Backrest	1
G	 Back Rail	1
H	 Front Rail	1
I	 Locking Block	2

No.	HARDWARE	QTY.
1	 M6x60mm Bolt	4
2	 M6x50mm Bolt	4
3	 M6x30mm Screw	4
4	 M6x50mm Screw	4
5	 Lock Nut	8
6	 Washer	8

INCLUDED TOOLS	
	Hex Key
	Spanner



2-PERSON
ASSEMBLY
RECOMMENDED

! HELPFUL HINT

Do not fully tighten hardware until all components are assembled. If hardware is tightened too soon, mounting holes may not align, and parts may not easily fit together.

! WARNING !

CHOKING HAZARD — This item contains small parts that can be swallowed. Keep children and pets away during assembly.

ASSEMBLY

Review all steps and understand assembly before beginning.

Do not fully tighten hardware until all components have been loosely assembled.

NOTE: When installing lock nuts, the metal thread goes on first. Hand-tighten until you feel resistance, which is caused by the nylon insert. A wrench will be required to fully tightening the lock nut. **Do not fully tighten hardware until Step 5 is complete.**

STEP 1

- B: 1
- C: 1
- D: 1
- E: 1
- 1: 2
- 5: 2
- 6: 2

TIP: Install bolt head on the inside of the chair, as shown.

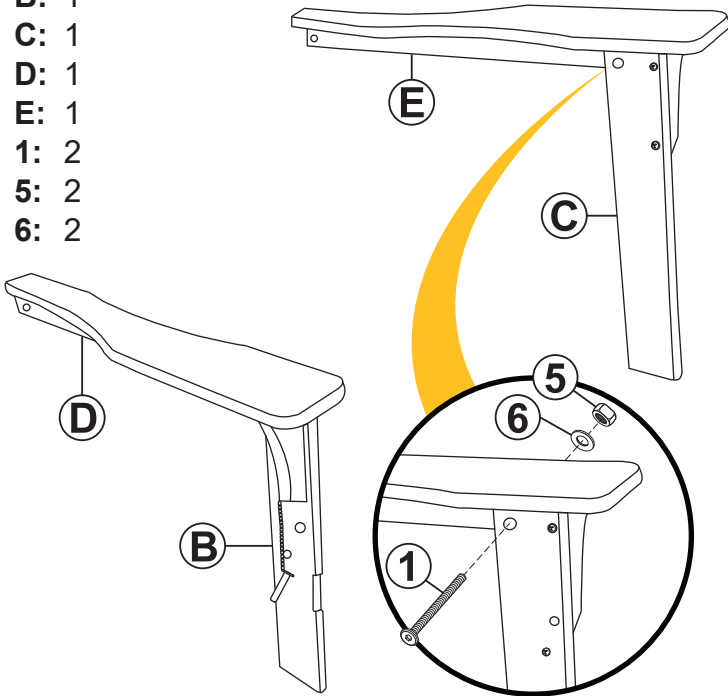

Do not fully tighten hardware until Step 5 is complete.

STEP 2

- A: 1
- 1: 2
- 5: 2
- 6: 2

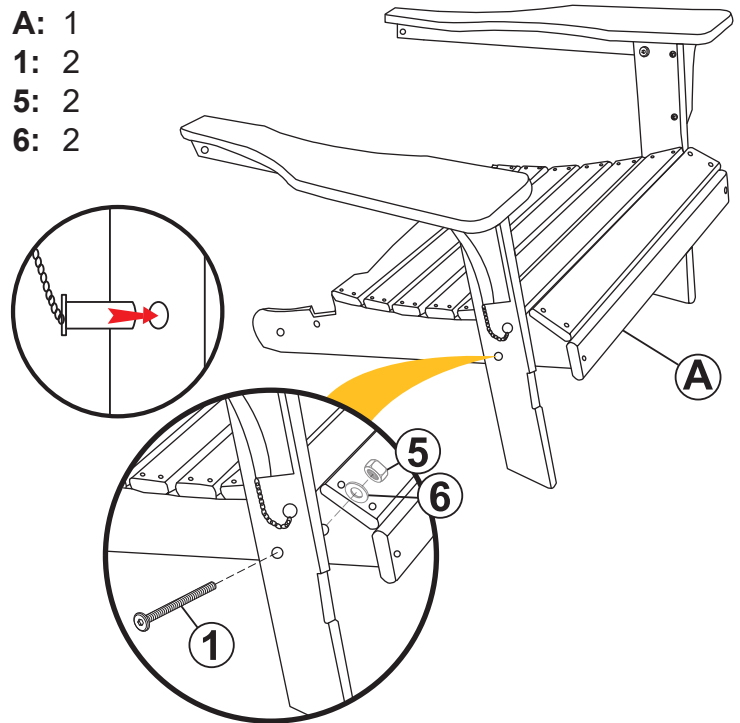

Do not fully tighten hardware until Step 5 is complete.

STEP 3

- F: 1
- 2: 2
- 5: 2
- 6: 2

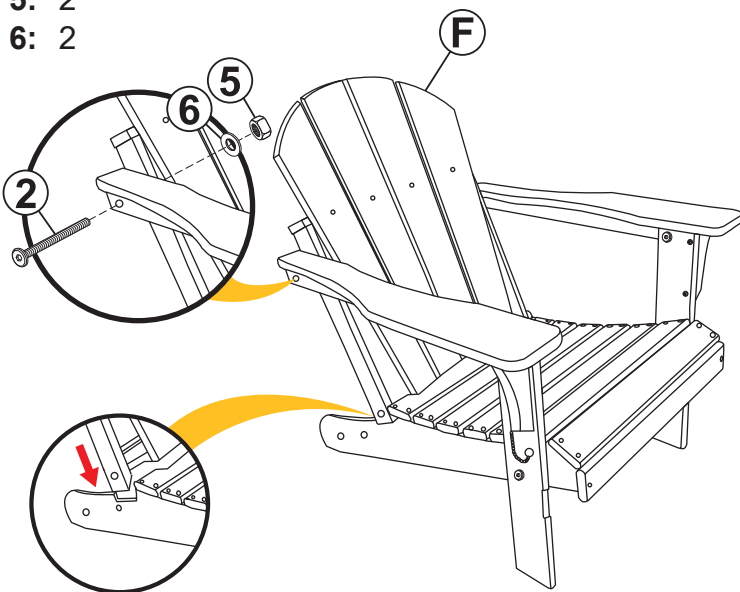

Do not fully tighten hardware until Step 5 is complete.

STEP 4

- l: 2
- 2: 2
- 4: 2
- 5: 2
- 6: 2

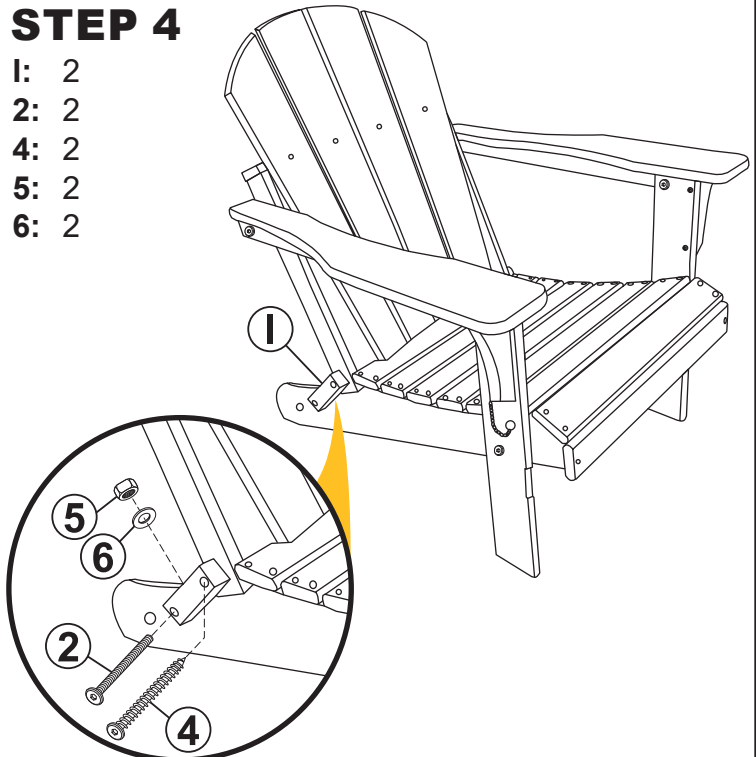

Do not fully tighten hardware until Step 5 is complete.

STEP 5

G: 1
H: 1
3: 4
4: 2

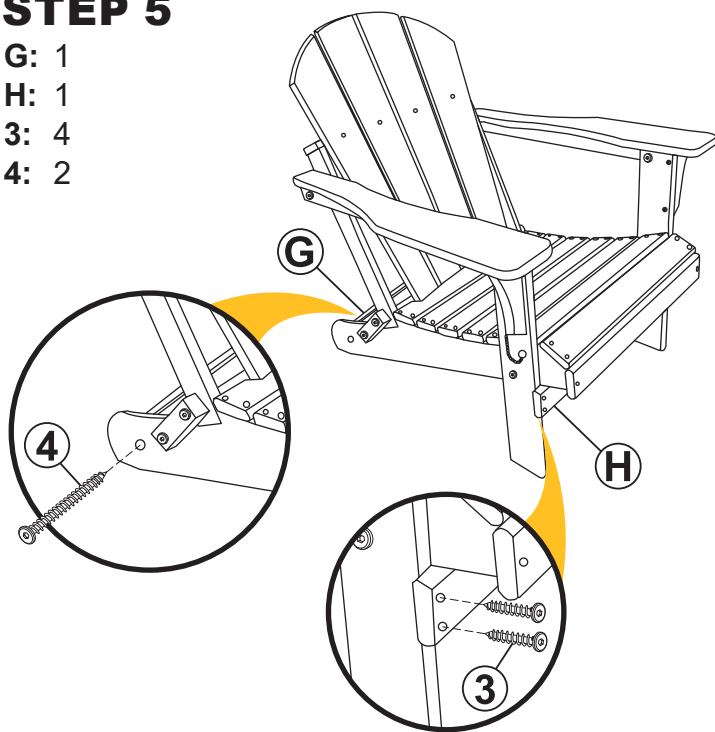

Fully tighten hardware from all steps after this step is complete.

TO FOLD: Pull the pins out from the legs, lift the backrest off the back of the seat and gently push the backrest toward the seat.

DO NOT step on the back rail when folding the chair as doing so may break the chair.

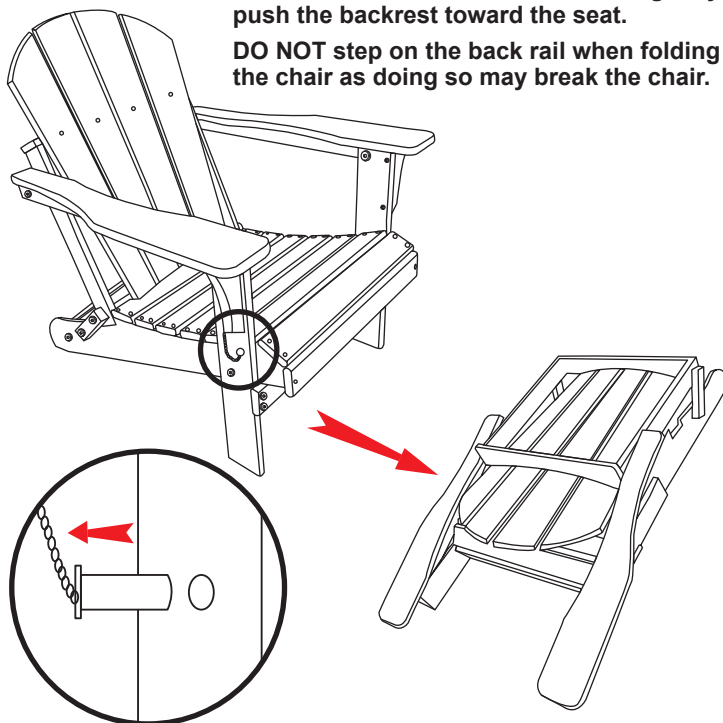

Care & Maintenance

SAFE USE: For residential use only. Only use on a flat, level surface. Ensure the pins in the front of the chair are fully inserted before each use. Do not stand on the chair. Do not exceed the weight capacity.

INSPECT: Periodically check hardware and tighten as necessary.

CLEAN: Mix a mild soap and water solution and wipe surfaces with a soft, non-abrasive cloth. Rinse with clean water, ensuring all soap residue has been removed. Do not use harsh chemicals or abrasive materials to clean.

WINTER CARE & STORAGE: Protect from inclement weather by moving furniture to an indoor location. Cover while in storage to help prevent dust build-up. When not in use, cover furniture with a breathable cover to help protect it from the effects of sunlight, inclement weather, dust build-up, and collecting debris.

! SAFETY STATEMENTS & WARNINGS !

- Do not exceed the weight capacity.
- Never stand on the chair.
- Inspect hardware often and tighten loose hardware before use.
- Do not put hot items on or near furniture.
- Keep furniture a safe distance from heat sources such as, but not limited to, fire pits, patio heaters, and grills.
- Do not allow children to use this product without adult supervision.
- Do not use harsh chemicals or abrasive materials to clean the furniture.

Any modification to the product or failure to follow recommended care will void the product warranty.

! WARNING:

Manufacturer and seller expressly disclaim any and all liability from personal injury, property damage or loss, whether direct or indirect, or incidental, resulting from the incorrect attachment, improper use, inadequate maintenance, or neglect of this product.