

OWNER'S MANUAL

Model: TSSK-300 (5301337)

(300 Gallon Skid-Mounted High Pressure Sprayer w/160cc Honda Engine & Electric Hose Reel)

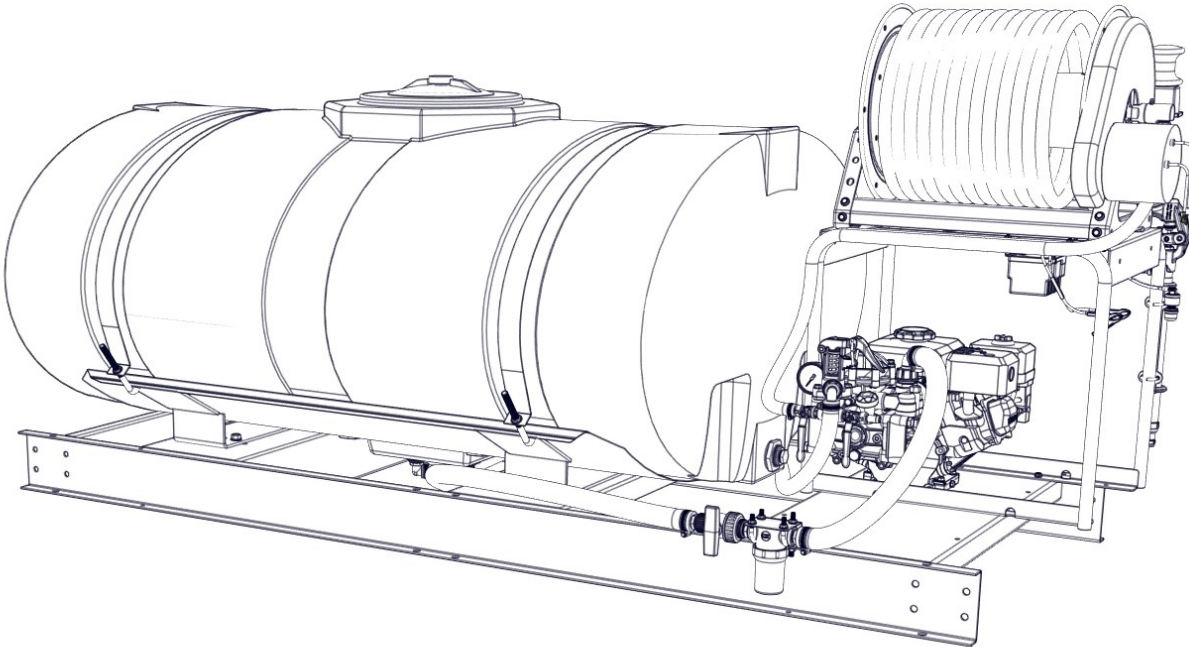

General Information

Thank you for purchasing this product. The purpose of this manual is to assist you in operating and maintaining your skid sprayer.

**BEFORE RETURNING THIS PRODUCT
FOR ANY REASON, PLEASE CALL**

1-800-831-0027

MONDAY-FRIDAY, 8:00 AM TO 5:00 PM CST

If you should have a question or experience a problem with your Fimco Industries Product: Visit our website @ www.fimcoindustries.com or call the Toll free number above. Our technical support representatives will be happy to help you. In most cases a customer service rep. can resolve the problem over the phone.

To obtain prompt, efficient service, always remember to give the following information....

- Correct Part Description and/or part number
- Model number and Serial Number

Part descriptions and numbers can be obtained from the illustrated parts list section(s) of this manual.

Retain a copy of your receipt for your unit, as it will be required to validate any warranty service.

Warranted against manufacturer or workmanship defects from date of purchase with copy of receipt:

Homeowner Usage: One Year

Commercial Usage: 90 Days.



WARNING: To reduce the risk of injury, the user must read and understand the operator's manual before using this product.



WARNING: Cancer and Reproductive Harm.
www.P65Warnings.ca.gov

IMPORTANT REMINDER:

Add proper oil to the engine crankcase and gasoline to the gas tank. Refer to the engine manual for the correct type and amount.

WARNING

This product when used can be dangerous and can cause bodily harm, if not properly used or guarded.

*** STAY AWAY FROM EQUIPMENT
WHEN IT IS IN OPERATION ***

Read information and the full instructions furnished with the product before installing and operating.



www.fimcoindustries.com

1000 FIMCO Lane, P.O. Box 1700, North Sioux City, SD 57049
Toll Free Phone: 800-831-0027 : Toll Free Fax: 800-494-0440
[5004739 (04/22)]

Contents

Technical Specs and Assembly Instructions	2	Sprayer Parts List.....	7
Operation	3	Electrical Components Exploded View/Parts List.....	8
Maintenance, Tank Care and Winter Storage	4	Sprayer Dimensions	8
HP Spray Gun and Lawn Spray Gun Info.....	5	Pump Troubleshooting.....	9
Sprayer Exploded Views	6 - 8	Warranty	10

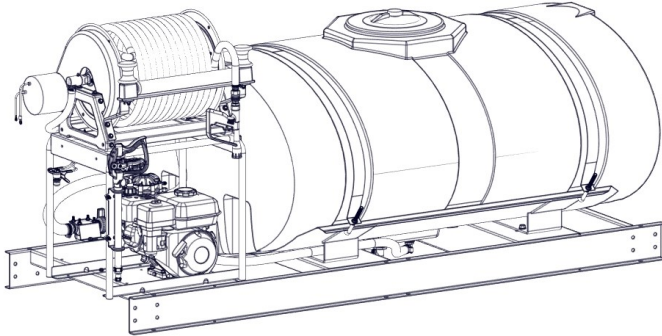

Model: TSSK-300 (5301337)
(300 Gallon Skid-Mounted High Pressure Sprayer
w/160cc Honda Engine & Electric Hose Reel)

Technical Specifications

- 300 Gallon Polyethylene Tank
- 160cc Honda Engine, Recoil Start
- Medium Pressure Diaphragm Pump
- Maximum Flow = 9.6 GPM
- Maximum Pressure = 580 PSI
- Maximum Temperature = 140°F
- GunJet Spray Gun w/1/2" x 300' of Hose

Caution: When fully filled with water, this sprayer will weigh approx. 3,095 lbs..
Consult the owner's manual for your vehicle to verify that you are within it's load carrying capacity.

~~~~~IMPORTANT~~~~~

Remove tank lid and be sure the tank is clean and free of any foreign material. Rinse tank out of any tank residue before filling with water to test.

~~~~~IMPORTANT~~~~~

It is VERY important to test this sprayer with plain water before actual spraying is attempted. This will enable you to familiarize yourself with the sprayer and check for leaks without the possibility of losing any expensive chemicals.

~~~~~WARNING~~~~~



Read and Understand the Owner's Manual before using this sprayer. Test and use in accordance to instructions.
Read and Follow chemical label instructions and wear protective gear when filling, using, cleaning and servicing the sprayer.

Exercise Caution in vehicle handling when towing/hauling a filled sprayer to avoid loss of control or overturning.

Keep Sprayer and Spray materials away from other people, children and pets.

Do Not Turn on Power to the sprayer, until ready to spray in order to avoid unintentional spray release.

Do Not Use on steep slopes. A full sprayer could cause loss of control or overturn sprayer and vehicle.

Always operate up and down a slope, never across the face of a slope.

Keep all movement on slopes slow and gradual. Do not make sudden changes in speed, directions or turning. Do not start or stop suddenly when going uphill or downhill.

Stop on level ground, set the parking brake and shut off engine before leaving the operator's position for any reason.

Keep all parts in good condition and properly installed. Fix damaged or worn parts immediately.

Caution should be taken when towing and/or using any sprayer. This sprayer combined with the weight distribution, turning radius and speed of vehicle can result in damage to vehicle and/or sprayer or severe injury or death, if not used properly.

Improper use of this sprayer or handling of chemicals could result in serious injury or illness, or could cause damage to the environment.

Assembly Instructions

The sprayer is completely assembled. It is ready to operate after mounting it securely on a truck bed.

Make sure all hose clamps are tight before testing or spraying for the first time.

~~~~~IMPORTANT REMINDER~~~~~

ADD proper oil to the engine crankcase and gasoline to the gas tank. Refer to the engine manual for the correct type and amount.

****The Sprayer is now ready to TEST w/plain water before actual use****

Before Operating the Sprayer

1. Add proper oil to the engine crankcase and gasoline to the gas tank. Refer to engine manual for correct oil type. Add SAE 30 to the sight level in the diaphragm pump. Fill the gear case with 90W gear lube until the gear lube runs out the side plug hole.
2. Add plain water to the tank and check the system for leaks. Open the suction line valve. Make sure the pressure regulator is in the (0 PSI) position.

Do not exceed recommended pressure on pump or sprayer, as it may cause hoses to burst and will shorten pump life.

IMPORTANT: Remove tank lid and be sure the tank is clean and free of any foreign material. Rinse tank out of any tank residue before filling with water to test.

Testing the Sprayer

NOTE:

It is important to test this sprayer for leakage and proper spray patterns with plain water before chemical application is attempted. This will also give you the opportunity to familiarize yourself with the operation of the sprayer, without the possibility of losing any expensive chemicals.

Operating the Sprayer

1. Adjust the pressure by clamping the relief valve adjustment lever down.
2. With the bale hook in the number one position, the pressure is about 100 psi; number two is about 250 psi; number three is about 450 psi; number four is about 550 psi.
3. Pressure can be adjusted by using the fine adjustment knob, located on top of the relief valve spring. The fine adjustment knob can be rotated when the relief valve lever is in the up position.
4. Pressure is released by lifting up the relief valve adjustment lever with the bale hook on the number one position.

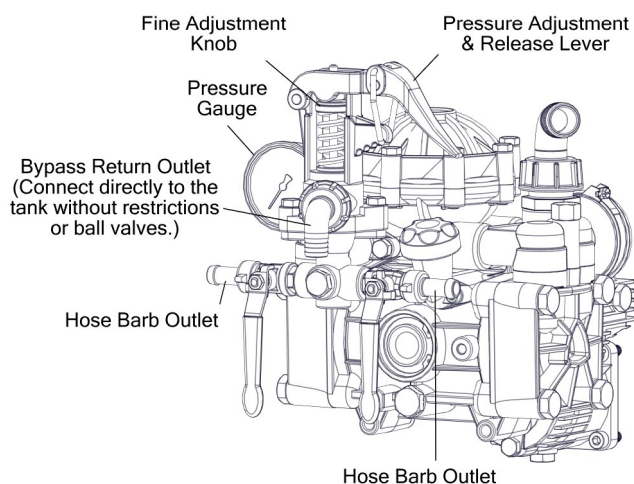

****NOTICE****

1. Be sure all guards covering exposed moving parts, such as shafts, are in place at all times. **DO NOT USE** the sprayer unless all guards are in place.
2. Test the sprayer with plain water before adding chemicals to the tank.
3. **DO NOT EXCEED** recommended speed, pressure and temperature for the sprayer and pump.
4. High pressure spray can cause serious bodily injury. Handle with care. Grasp gun firmly before starting to spray. During spraying operation, hold gun firmly.
5. **DO NOT** put hands or fingers in front of the gun or point the gun at your body or anyone else.
6. Before working on, servicing or making adjustments to equipment, disengage power, shut off engine, make sure all moving parts have stopped and all pressure in the system is relieved.
7. Perform periodic cleaning, maintenance and inspection of fittings and hoses for operator safety. Replace any fittings or hoses that are shown to have defects.
8. **DO NOT** use sprayer for pumping water or other liquid for human or animal consumption.
9. If equipment is used in freezing or near freezing conditions, protect pump and plumbing on sprayer from freezing. Drain liquid from system and add antifreeze (containing a rust inhibitor).
10. **Only fill the tank with what you're going to spray in a day, never leave chemicals sit in tank.**

WARNING: Never pump corrosive or abrasive liquids as these will cause rapid wear or deterioration of body, rotor, shaft and seals in the pump. Never run pump dry. Some chemicals will damage the pump valves if allowed to soak untreated for a length of time! ALWAYS flush the pump as instructed after each use. **DO NOT** allow chemicals to sit in the pump for extended times of idleness. Failure to follow this warning will void the product warranty.

Maintenance During/After Spraying

Periodically close the suction line valve and check the line strainer and clean the screen. Stop the engine and shut off the valve near the strainer. Remove the bowl and screen portions of the strainer and wash them free from all impurities. You may also drain the tank by uncoupling the suction line near the strainer. Open the valve and pour the contents into another container. Read the chemical label for disposal instructions.

Proper care and maintenance will keep your pump wear at a minimum and will keep it running smoothly and trouble-free for a long time and prolong the life of your sprayer.

Change the engine oil per the engine manufacturer's specifications. Oil changes in the pump should be done after each 200 hours of use or at least once a season. To fill the pump with oil, pour oil slowly into the sight tube while slowly turning the pump shaft. Turning the pump shaft purges all of the air from the crankcase. Use SAE 30 motor oil.

Refer to the pump and motor owners manuals for their respective replacement parts and service recommendations.

After use, fill the sprayer tank part way with water. Start the sprayer and allow the water to pump through the entire plumbing system and nozzles. Drain and then refill half full with plain water, add the recommended amount of good quality tank cleaner such as FIMCO Sprayer Tank Neutralizer and Cleaner. (If no tank cleaner is available, you may substitute dish soap for this step, about 1-2 oz. per gallon). But a neutralizer/cleaner should be used to thoroughly clean the system. Turn sprayer on and circulate through system for 15 minutes and then spray out through handgun nozzle (and boom nozzles if applicable). Refill tank half way with clean water and repeat. Follow the chemical manufacturer's disposal instructions of all wash or rinsing water.

For the boom (if applicable) remove the tips and screens from the nozzle assemblies. Wash these items out thoroughly. Blow the orifice clean and dry. If the orifice remains clogged, clean it with a fine bristle (NOT WIRE) brush or with a toothpick. Do not damage the orifice. Water rinse and dry the tips before storing.

Follow the chemical manufacturer's instructions on disposal of all waste water from the sprayer.

Tank Care & Maintenance

Warning: Do not use the tank as a container for fuel oils, kerosene, gasoline or any other petroleum distillate product. All polyolefins are softened and permeated by such products. In an enclosed area the vaporization of these materials from the outside surface of the tank could create a dangerous condition.

The tank should not be used as a pressure vessel nor used with chemicals or solutions having a weight of more than 12 pounds per gallon.

Store the tank in a dry dark place when not in use. Storage out of sunlight will prolong the life of the tank.

Do not drop, strike or kick the tank, especially at low temperatures. Tanks become brittle and are subject to cracking at temperatures below 20° Fahrenheit.

Always flush the tank with water and a neutralizing agent at the end of each use, to prevent contamination of solutions.

Winter Storage

Prepare the sprayer for end-of-season storage by draining all water out of your sprayer, paying special attention to the pump, handgun and valve(s). These items are especially prone to damage from chemicals and freezing weather.

The sprayer should be winterized before storage by pumping a solution of automotive antifreeze (containing a rust inhibitor) through the entire plumbing system. This antifreeze solution should remain in the plumbing system during the winter months. When spring time comes and you are preparing your sprayer for the spray season, rinse the entire plumbing system out, clearing the lines of the antifreeze solution. Dispose of antifreeze and flush water properly.

Proper care and maintenance will prolong the life of your sprayer.

It is nearly impossible to drain all of the water from the sprayer and any trapped water can freeze in cold weather and damage parts of the sprayer. Pumping the antifreeze through the system will displace the water and help prevent this damage.

PRO SERIES Long Range Ergonomic Handguns

Technical Specifications:

- Adjustable Spray Pattern
- No Drip Shut Off
- Adjustable On/Off Trigger Stop for Precise Spray Pattern
- Aluminum Barrel
- Ergonomic Handgun Design
- Integrated Trigger Lock
- Convenient Hanger Hole
- 600 PSI, 8 GPM
- Chemical Resistant Construction
- 38' Horizontal, 27' Vertical Maximum Spray Distance

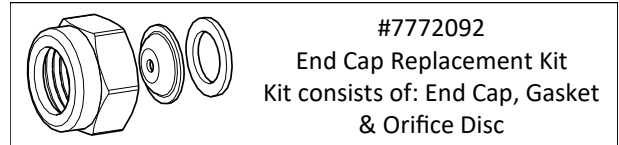
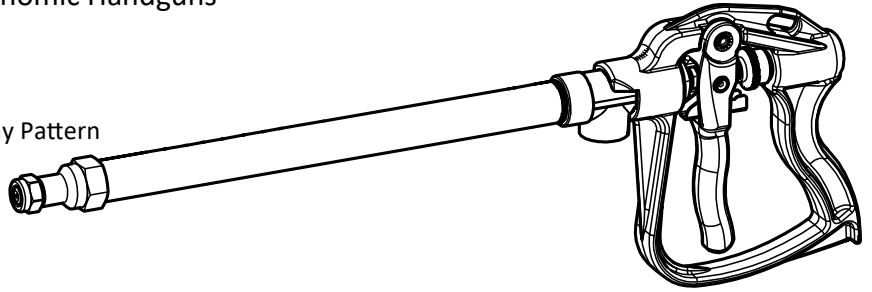

#7772092
End Cap Replacement Kit
Kit consists of: End Cap, Gasket
& Orifice Disc

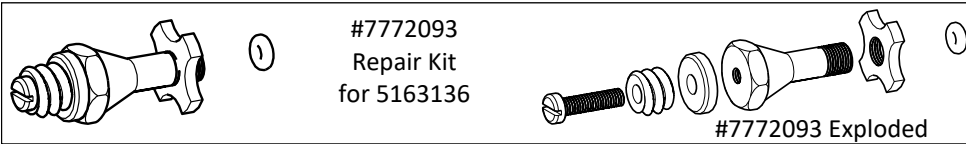

#7772093
Repair Kit
for 5163136

#7772093 Exploded

25660 Lawn Spray Gun

Features:

- Nozzle tips provide a 45° full cone "showerhead" spray pattern.
- Convenient trigger lock for continuous spraying.

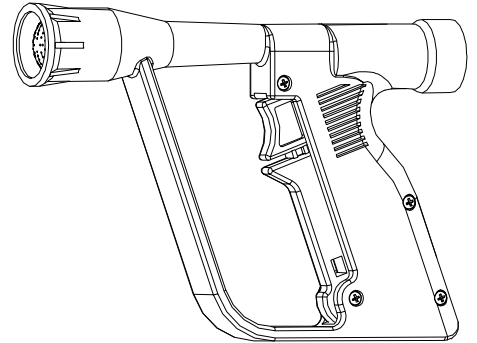

Comes w/
Black Nozzle
5138569

Nozzle #	Fimco #	Capacity (GPM) at Various Pressure*							
		Nozzle Mfg. #	2 PSI	4 PSI	6 PSI	8 PSI	10 PSI	15 PSI	20 PSI
Gray 1.5	5138568	CP25670-1.5-NY	1.4	1.9	2.3	2.6	2.9	3.4	4.0
Black 3.0	5138569	CP25670-3.0-NYB	2.0	2.7	3.2	3.6	4.1	4.9	5.6
Red 4.0	5138570	CP25670-4.0-NY	2.3	3.1	3.7	4.3	4.7	5.6	6.4

*Pressure measured at spray nozzle

Gray 1.5 and Red 4.0 or optional nozzle tip accessories and do not come with this sprayer.

Exploded View: TSSK-300 (5301337)

Refer to Parts List next page for Part Numbers

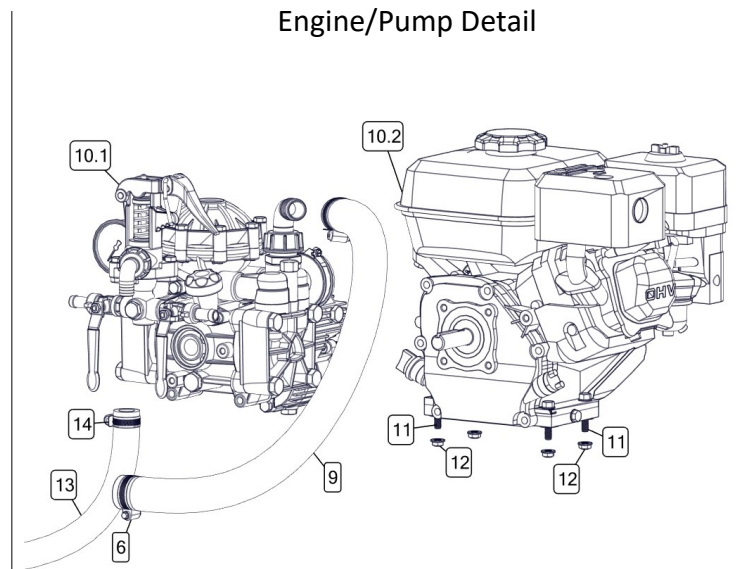
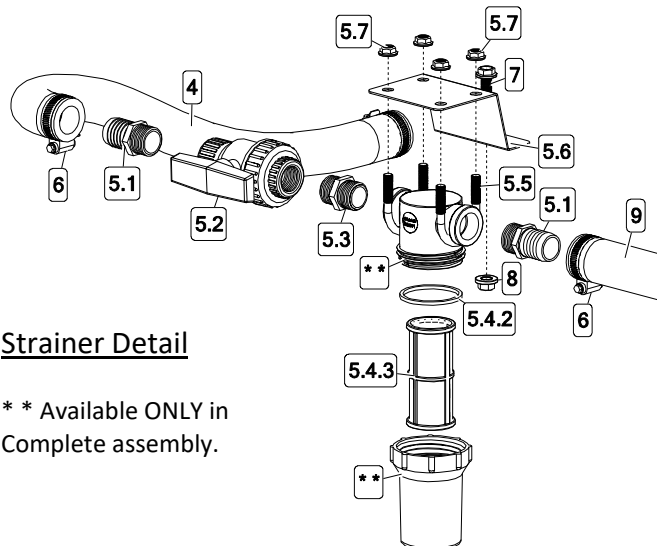
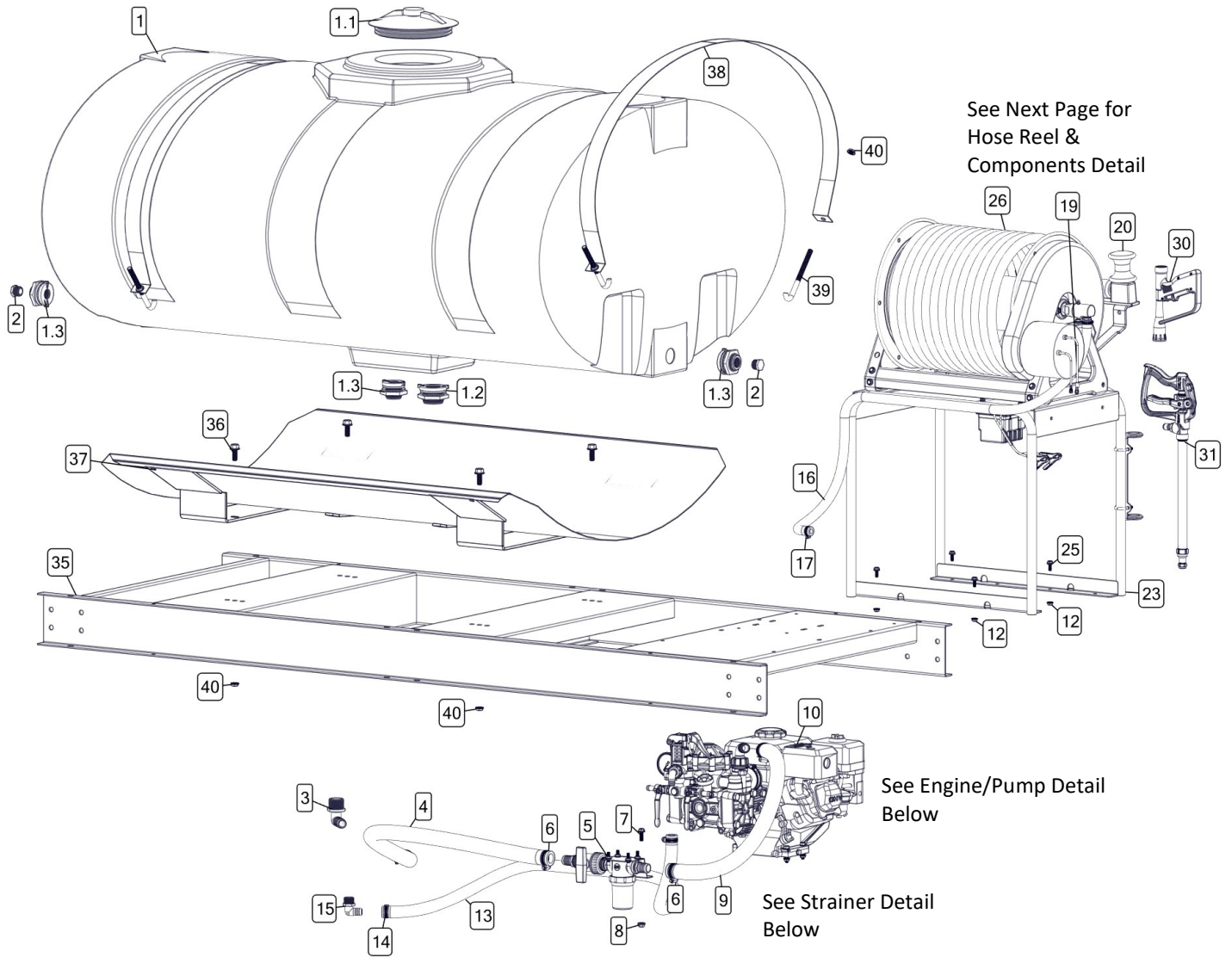

Hose Reel (misc.) Components (TSSK-300 Setup)

Refer to Parts List Below
for Part Numbers

See Electrical Components
Next Page

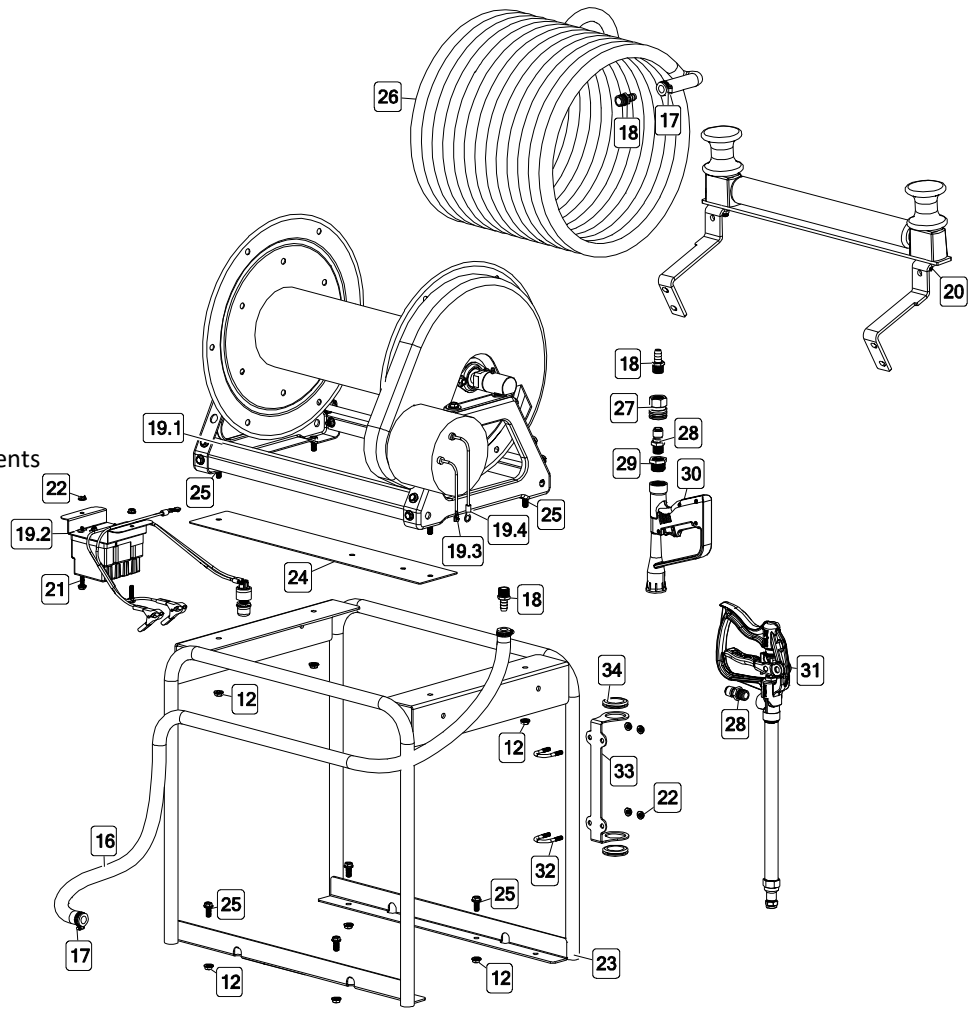

Parts List: TSSK-300 (5301337)

Ref. #	Part #	Description	Qty
1	5169081	300 Gallon Elliptical Tank (White)	1
1.1	63485	16" Tank Lid & Ring w/Blue Snap-In Lid	1
1.2	5274362	1-1/4" Double-Threaded Bulkhead	1
1.3	5273736	3/4" Double-Threaded Tank Bulkhead	3
2	5102071	Poly Pipe Plug, 3/4" MNPT	2
3	5010215	Poly Elbow, 1 1/4" MNPT x 1" HB	1
4	5020962	Hose, 1" - 2-Brd. x 46"	1
5	5277601	Strainer Assembly	1
5.1	5067128	Poly Fitting, 3/4" MNPT x 1" HB	2
5.2	5143206	3/4" Single Union Ball Valve	1
5.3	5011140	Poly Close Nipple, 3/4" MNPT	1
5.4	5116443	3/4" Black Poly Strainer, 50 Mesh	1
5.4.1	**	Strainer Cap	1
5.4.2	5072540	Strainer Gasket	1
5.4.3	5116456	50 Mesh Strainer Screen	1
5.4.4	**	Strainer Bowl	1
5.5	5034065	5/16-18 x 1.5 x 2.1875 Round U-Bolt	2
5.6	5038258-BLK	Strainer Bracket	1
5.7	5006307	5/16-18 Serrated Fling Hex Nut	4
6	5051025	Hose Clamp, 1"	4
7	5117307	3/8-16 x 1.00 Fling Hex Bolt	1
8	5006259	3/8-16 Serrated Fling Hex Nut	1
9	5020975	Hose, 1"-2 Brd. x 27"	1
10	5282506	AR30 Pump/Honda GX160 Assembly	1
10.1	5151161	AR Two Diaphragm Pump w/6:1 & Control	1
10.2	5152058	160cc Honda (OHV) (Less Gear Reduction)	1
11	5034638	5/16-18 x 1.50 Fling Hex Bolt (Full Thread)	4
12	5006307	5/16-18 Serrated Fling Hex Nut	12
13	5020485	Hose, 3/4"-2 Brd. x 64"	1
14	5051024	Hose Clamp, 3/4"	2
15	5010209	Poly Elbow, 3/4" MNPT x 3/4" HB	1
16	5020488	Hose, 1/2" Yellow PVC x 60" (600#)	1

Ref. #	Part #	Description	Qty
17	5051114	Hose Clamp, 1/2"	4
18	5067052	Steel Fitting, 1/2" MNPT x 1/2" HB	3
19	5274309	Electric Hose Reel Assembly	1
19.1	5272183	Electric Hose Reel	1
19.2	5275416	Electric Components Assembly	1
19.3	5157065	1/4" Female Push-On Terminal (10-12 Ga.)	1
19.4	5157063	Ring Terminal Lug, 3/8" (10-12 Ga.)	1
20	5274371	Spool Kit for Hannay 1500 Series Hose Reel	1
21	5117301	1/4-20 x 1.00 Fling Hex Bolt	2
22	5006306	1/4-20 Serrated Fling Hex Nut	6
23	5274195-BLK	Reel Mount Weldment	1
24	5038705-BLK	Electric Hose Reel Mounting Bracket	1
25	5117323	5/16-18 x 0.75 Fling Hex Bolt	8
26	5153097	Hose, 1/2" PVC 600# (Yellow) x 300 Ft.	1
27	5126003	SS Quick Connector Female Coupler Socket	1
28	5102121	SS Quick Connector Male Coupler Plug	2
29	5041078	Reducer Bushing, 3/4" MNPT x 1/2" FNPT	1
30	5163038	GunJet Spray Gun	1
30.1	25660-0	Lawn Spray Gun - Less Nozzle	1
30.2	5138569	Black Nozzle for 25660 Lawn Gun	1
31	5163136	High Pressure Aluminum Spray Gun 22"	1
32	5034197	1/4-20 x 1.00 x 1.75 Round U-Bolt	2
33	5038637-BLK	Handgun Holder Bracket	1
34	5075014	Rubber Grommet (Black)	2
35	5274303-RED	Skid Weldment	1
36	5034691	1/2-13 x 1.25 Fling Hex Bolt	4
37	5273183-BLK	Saddle Weldment (300E)	1
38	5133227	Tank Strap (300E)	2
39	5034111	1/2-13 x 6.00 Hook Bolt	4
40	5006337	1/2-13 Serrated Fling Hex Nut	8

Electrical Components Assembly (5275416)

Ref. #	Part #	Description	Qty
1	5006186	#10-24 Serrated Flng Hex Nut	3
2	5157025	Strain Relief	1
3	5272286-BLK	Electrical Components Base	1
4	5157075	Solenoid (12 Volt)	1
5	5157057	Auto-Reset Circuit Breaker (40 Amp)	1
6	5117234	#10-24 x 0.50 PH Truss Head Screw	2
7	5117334	#10-24 x 0.50 PH Round Head Screw	1
8	5272287	Battery Wire Assembly	1
9	5272289	Jumper Wire Assembly	1
10	5272290	Push-Button Switch Assembly	1
11	5272288	Lead Wire Assembly (Positive)	1
12	5058101	Switch Box Cover	1
13	5117176	#10-24 x 0.75 PH Truss Head Screw	2

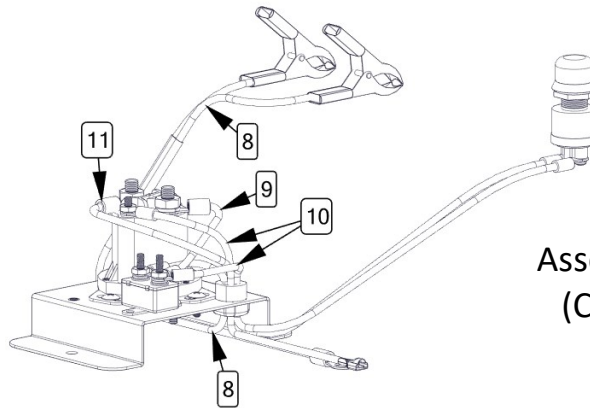
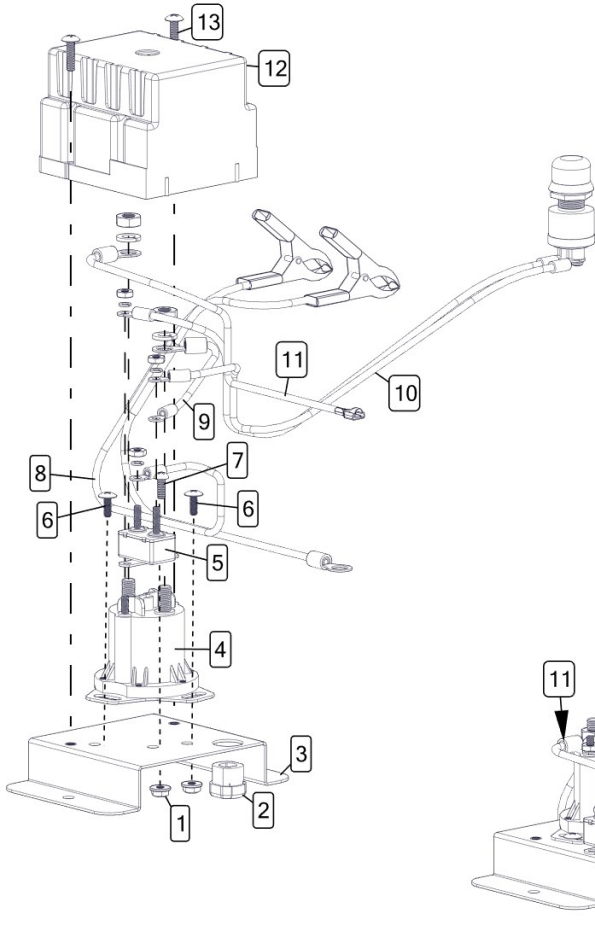

Assembled Switchbox
(Cover not shown)

Approx. Dimensions:

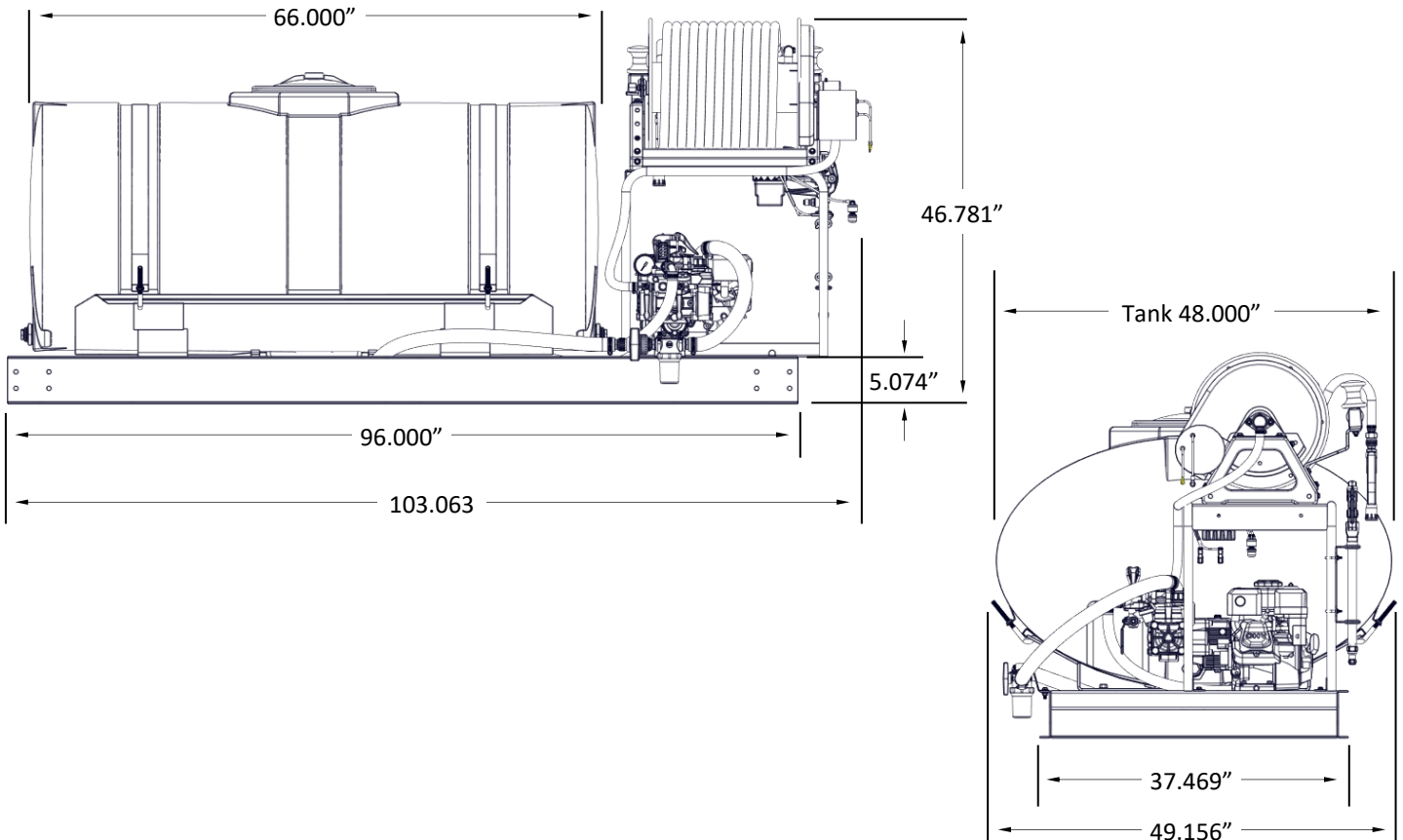

Pump Troubleshooting		
Problem	Cause	Remedy
Pump does not prime properly.	Intake circuit not airtight.	Tighten, repair or replace hoses and fittings, as necessary.
	Control unit switching lever on "Pressure" setting.	Move control switching lever to "By-pass" setting.
Pump does not require the required pressure.	Seat and plate of intake and delivery valves worn.	Replace the worn valves.
	Nozzle worn or too large in diameter.	Replace the worn nozzles. Use nozzles of suitable diameter.
	Restriction in intake circuit.	Remove the restriction from the circuit.
	Intake filter fouled.	Clean the filter cartridge.
Pressure gauge needle wobbles, pressure pulsating.	Intake circuit not airtight.	Clean or replace the intake and delivery valves.
	Residual air left inside pump.	Discharge the air by opening a ball valve/central unit connected to the delivery side with the pump in operation.
	Valve plate stuck to it's seat.	Tighten, repair or replace hose and fittings as necessary.
	Pressure accumulator deflated.	Inflate accumulator to the correct pressure.
Uneven flow of liquid to nozzles.	Pressure accumulator deflated.	Inflate accumulator to the correct pressure.
Increase in noise and simultaneous drop in oil level (pump cavitation).	Restriction in intake circuit.	Remove the restriction from the circuit.
	Intake filter fouled.	Clean the filter cartridge.
	Pump drawing in liquid from too low a level.	See "Pump Intake Conditions" section in Pump Manual.
Oil on pump body or base.	Oil seal on pump shaft worn.	Replace the worn oil seal.
	Oil pressure inside pump too high.	Restore correct oil level in tank.
Pump using too much oil(oil flowing from delivery port) or oil whitish in color (water/oil emulsion in tank).	One or more diaphragms ruptured.	Stop the pump at once. Replace the diaphragm.

Warranty Info

LIMITED WARRANTY FOR NEW FIMCO, INC.

WHO MAY USE THIS LIMITED WARRANTY. This limited warranty (the "Limited Warranty") is provided by Fimco, Inc. to the original purchaser ("you") of the Equipment (as defined below) from Fimco, Inc. or one of Fimco, Inc.'s authorized dealers. This Limited Warranty does not apply to any subsequent owner or other transferee of the Equipment. THIS LIMITED WARRANTY GIVES YOU SPECIFIC LEGAL RIGHTS, AND YOU MAY ALSO HAVE OTHER RIGHTS WHICH VARY FROM STATE TO STATE.

WHAT THIS LIMITED WARRANTY COVERS AND FOR HOW LONG. Fimco, Inc. warrants that any registered new Equipment will be free from defects in material and workmanship for a period of **one (1) year** (homeowner), **90 days** (commercial user), after delivery of the Equipment to you (the "Warranty Period"). The Warranty Period is not extended if Fimco, Inc. repairs or replaces the Equipment.

WHAT IS NOT COVERED BY THIS LIMITED WARRANTY. This Limited Warranty does not apply to: (1) used Equipment; (2) any Equipment that has been altered, changed, repaired or treated since its delivery to you, other than by Fimco, Inc. or its authorized dealers; (3) damage or depreciation due to normal wear and tear; (4) defects or damage due to failure to follow Fimco, Inc.'s operator's manual, specifications or other written instructions, or improper storage, operation, maintenance, application or installation of parts; (5) defects or damage due to misuse, accident or neglect, "acts of God" or other events beyond Fimco, Inc.'s reasonable control; (6) accessories, attachments, tools or parts that were not manufactured by Fimco, Inc., whether or not sold or operated with the Equipment; or (7) rubber parts, such as tires, hoses and grommets.

HOW TO OBTAIN WARRANTY SERVICE. To obtain warranty service under this Limited Warranty, you must (1) provide written notice to Fimco, Inc. of the defect during the Warranty Period and within **thirty (30) days** after the defect becomes apparent or the repair becomes necessary, at the following address: Fimco, Inc., 1000 Fimco Lane, North Sioux City, SD 57049; and (2) make the Equipment available to Fimco, Inc. or an authorized dealer within a reasonable period of time. For more information about this Limited Warranty, please call: **800-831-0027**

WHAT REMEDIES ARE AVAILABLE UNDER THIS LIMITED WARRANTY. If the conditions set forth above are fulfilled and the Equipment or any part thereof is found to be defective, Fimco, Inc. shall, at its own cost, and at its option, either repair or replace the defective Equipment or part. Fimco, Inc. will pay for shipping and handling fees to return the repaired or replacement Equipment or part to you.

LIMITATION OF IMPLIED WARRANTIES AND OTHER REMEDIES. THE REMEDIES DESCRIBED ABOVE ARE YOUR SOLE AND EXCLUSIVE REMEDIES, AND FIMCO, INC.'S SOLE LIABILITY, FOR ANY BREACH OF THIS LIMITED WARRANTY. TO THE EXTENT APPLICABLE, ANY IMPLIED WARRANTIES, INCLUDING, WITHOUT LIMITATION, THE IMPLIED WARRANTIES OF MERCHANTABILITY AND FITNESS FOR A PARTICULAR PURPOSE, SHALL BE LIMITED IN DURATION TO THE WARRANTY PERIOD, AND THE REMEDIES AVAILABLE FOR BREACH THEREOF SHALL BE LIMITED TO THE REMEDIES AVAILABLE UNDER THIS EXPRESS LIMITED WARRANTY. SOME STATES DO NOT ALLOW LIMITATIONS ON HOW LONG AN IMPLIED WARRANTY LASTS, SO THE ABOVE LIMITATION MAY NOT APPLY TO YOU. IN NO EVENT SHALL FIMCO, INC.'S LIABILITY UNDER THIS LIMITED WARRANTY EXCEED THE ACTUAL AMOUNT PAID BY YOU FOR THE DEFECTIVE EQUIPMENT, NOR SHALL FIMCO, INC. BE LIABLE, UNDER ANY CIRCUMSTANCES, FOR ANY CONSEQUENTIAL, INCIDENTAL, SPECIAL OR PUNITIVE DAMAGES OR LOSSES, WHETHER DIRECT OR INDIRECT. SOME STATES DO NOT ALLOW THE EXCLUSION OR LIMITATION OF INCIDENTAL OR CONSEQUENTIAL DAMAGES, SO THE ABOVE LIMITATION OR EXCLUSION MAY NOT APPLY TO YOU.