

# LOYAL MANURE SPREADER

## Model MS23B

### Owner's and Operator's Manual



Read and Understand this manual  
*Before Operating*



**WARNING:** This manure spreader has rotating parts & shafts. Use care during operation and maintenance.

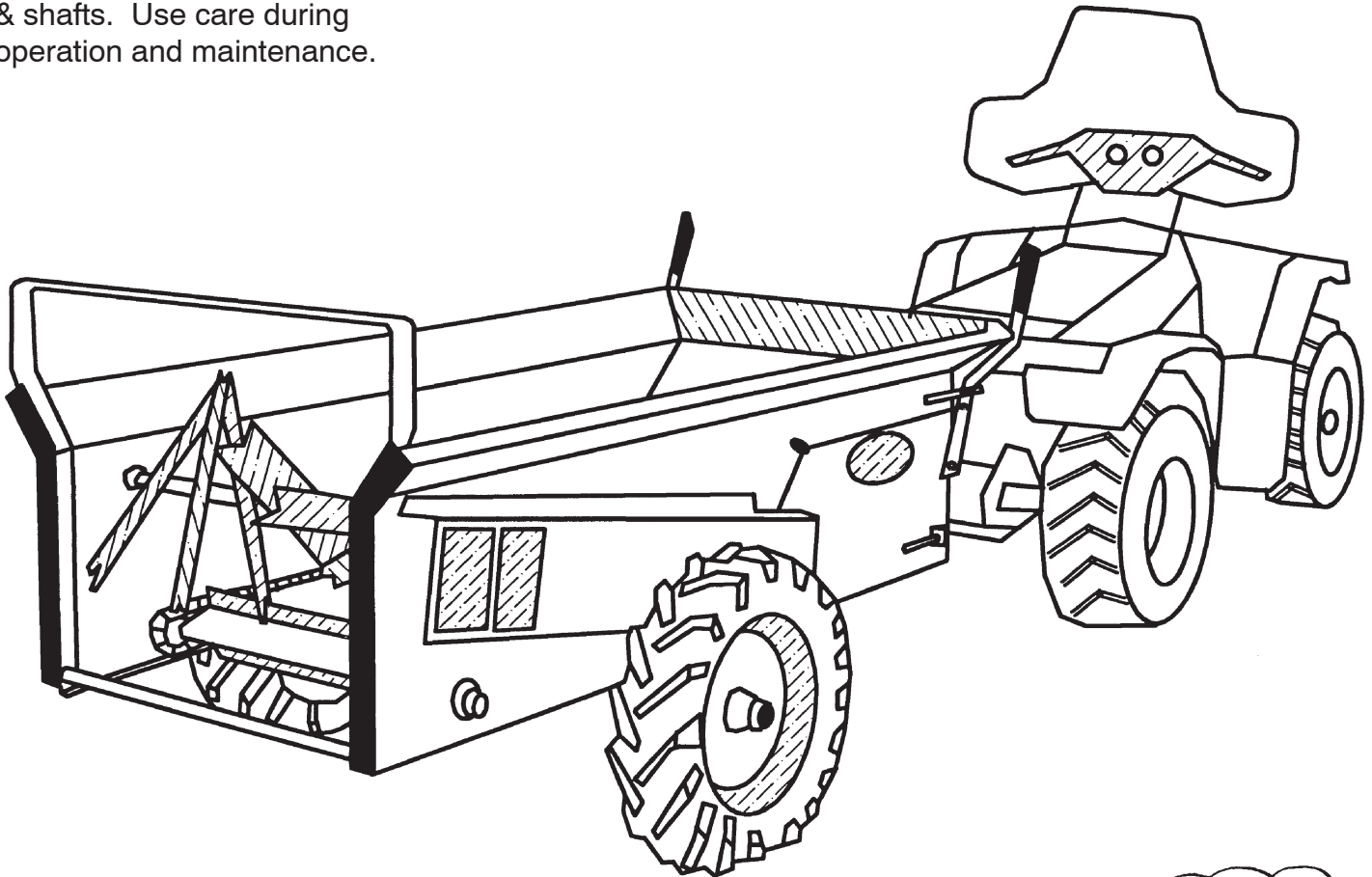

#### **IMPORTANT**

This manure spreader was test-run, inspected, and carefully packaged prior to shipment. Note any visible damage or shortages on carrier's delivery receipt before signing. If there is concealed damage, do not dispose of packing materials. Contact us immediately so a timely freight claim can be filed.



#### **Additional Assistance**

If any items covered in this manual are not fully understood by you, contact your dealer or T.R. Metal Crafters, Inc., 312 E. Industrial Drive, P.O. Box 248, Loyal, WI 54446, (call TOLL FREE 1-800-842-5349) for assistance.

# General Safety Statement

It is your responsibility as an owner, operator or supervisor to know what specific requirements, precautions and work hazards exist and to make these known to all other personnel working with the equipment or in the area, so that they too may take any necessary safety precautions that may be required. Failure to read this Owner's and Operator's Manual and its safety instructions is a misuse of the equipment.



## The Operator's Manual



Anyone who will operate or work around this equipment, shall first read the Owner's and Operator's Manual!

*Complete sign-off sheet in "Operator Qualifications" section of this Manual to document training.*



## Safety Alert Symbol

This Safety Symbol means:

**Attention!  
Become Alert!  
Your Safety Is Involved!**

The Safety Alert Symbol identifies important safety messages on machines, safety decals, in manuals, or elsewhere. When you see this symbol, be alert to the possibility of personal injury or death. Follow the instructions in the safety message.

This symbol will be used with one of three signal words: **CAUTION** **WARNING** **DANGER** to indicate the degree of hazard.

**CAUTION** — Hazards or unsafe practices which **COULD** result in minor personal injury or product or property damage.

**WARNING** — Hazards or unsafe practices which **COULD** result in severe personal injury or death.

**DANGER** — Immediate hazards which **WILL** result in severe personal injury or death.

## Why is Safety important to You?

### 3 Big Reasons:

- **Accidents Disable and Kill**
- **Accidents Cost**
- **Accidents Can Be Avoided**

# Foreword

This Manual is intended to point out some of the basic situations which may be encountered during the normal operation and service of your machine and to suggest possible ways of dealing with these conditions.

Additional precautions may be necessary, depending on conditions at the worksite or in the service area. The manufacturer has no direct control over machine application, operation, inspection, lubrication, or maintenance. Therefore, it is your responsibility to use good safety practices in these areas.

Other information which may affect the safe operation of your machine may be contained on safety decals, or in insurance requirements; employer's safety programs; safety codes; and local, state, and federal laws, rules, and regulations.

If you require information not covered in this manual, contact T.R. Metal Crafters Inc., 312 E. Industrial Drive, P.O. Box 248, Loyal, WI 54446 (call TOLL-FREE 1-800-842-5349).

Because Loyal engineers are constantly improving products, T.R. Metal Crafters Inc. reserves the right to change design and/or specifications without notice. The information on this document does not constitute a warranty by T.R. Metal Crafters Inc.

# Table of Contents

General Safety Statement ..... Inside Front Cover  
Foreword .....1  
Decal Location.....3  
Operator Qualifications and Sign Off Sheet .....4  
Assembly Instructions.....5  
Safety & Accident Prevention .....6,7  
Operating Instructions .....8  
Service and Maintenance .....9, 10  
Warranty Registration Card .....Insert  
Warranty .....11  
Parts Lists..... 12-17

## **Right and Left Identification**

References to "right" and "left" in this manual are based on the operator standing at the rear of the spreader, looking toward the front of the spreader.

# The Decals Shown On This Page Must Be Displayed As Shown Below

FREE REPLACEMENTS ARE AVAILABLE UPON REQUEST

Contact T.R. Metal Crafters Inc., 312 E. Industrial Drive, P.O. Box 248, Loyal, WI 54446.

(Call TOLL-FREE 1-800-842-5349)

Safety decals must be replaced if they are destroyed, missing, painted over, or can no longer be read. New equipment components installed during repair shall be equipped with the same safety decals that were affixed to the original components. Keep decals wiped clean at all times.

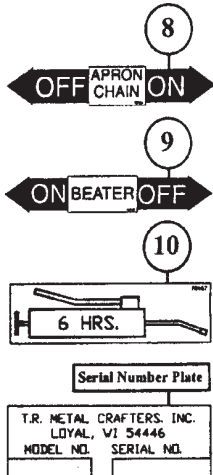
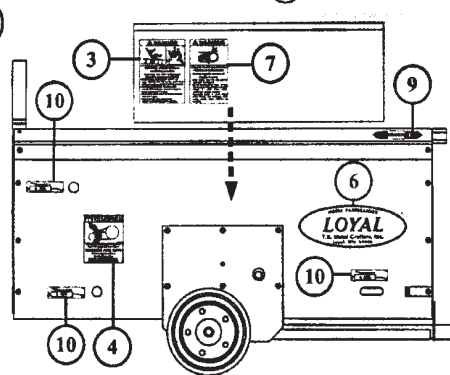
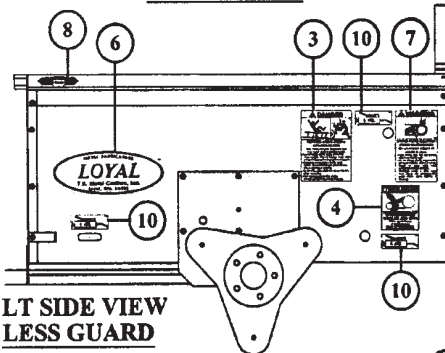
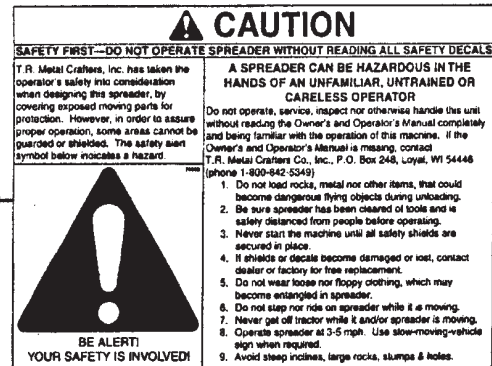
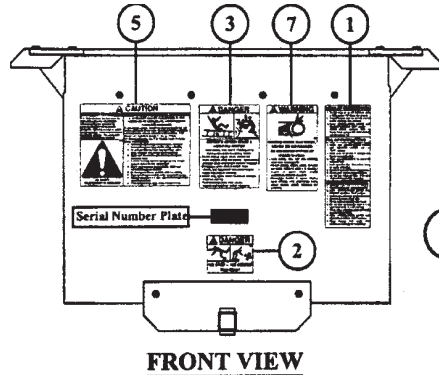

**HOOK-UP INSTRUCTIONS**

1. Tractor must be 10 HP minimum, with a hitch approx. 10" above the ground.
2. Shut off tractor and set parking brake, before attaching onto spreader.
3. Move APRON-CHAIN LEVER and BEATER LEVER to "OFF" position.
4. Attach manure spreader hitch to tractor hitch, using a 5/8" hitch pin that will not bounce out.

**FILL-UP INSTRUCTIONS**

1. Make sure APRON-CHAIN LEVER and BEATER LEVER are in "OFF" position.
2. Make sure no chunks of manure are frozen to spreader floor.
3. Make sure apron chain is not frozen to spreader floor.
4. Load spreader from front toward back for easier unloading.
5. Do not fill spreader above side panels.
6. Do not pack manure against beaters.
7. Do not load string nor wire. They can wind onto beater while unloading.

**SPREADING INSTRUCTIONS**

1. Shut off tractor and set parking brake.
2. Move APRON-CHAIN LEVER and BEATER LEVER to "ON" position.
3. Start tractor and begin moving forward.
4. Operate spreader at 3-5 mph.
5. Do not operate spreader over 5 mph.
6. Do not back up spreader when it is in unloading mode, to avoid damage.
7. When done unloading, shut off tractor and set parking brake.
8. Move APRON-CHAIN LEVER and BEATER LEVER to "OFF" position.
9. Clean manure from cracks and corners, to increase life of spreader.

Key No.	Description	Qty.	Item No.
1	Decal, Spreader "Instructions"	1	70166
2	Decal, Danger - "No Step, No Riders"	1	70163
3	Decal, Danger - "Exposed Apron Chain & Rotating"	3	70161
4	Decal, Danger - "Shields Are Off"	2	11097
5	Decal, Caution - "A Spreader Can Be Hazardous"	1	70160
6	Decal, "Loyal / TRM" Large Oval	2	70292
7	Decal, Warning - "Moving Parts Can Pinch"	3	70162
8	Decal, "Apron Chain, On / Off"	1	70164
9	Decal, "Beater, On / Off"	1	70165
10	Decal, Grease Every "6 Hrs"	6	70167
11	Manual Assembly, MS23B Manure Spreader Owner's	1	YA70293B

# 4 Operator Qualifications and Sign Off Sheet

Operation of this machine shall be limited to competent and experienced persons. In addition, anyone who will operate or work around this machine must use good common sense. In order to be qualified, he must also know and meet all other requirements, such as:



1. Some regulations specify that no one under the age of 18 may operate power machinery. This includes this machine. It is your responsibility to know what these regulations are in your own area or situation.
2. Current OSHA regulations state in part: "At the time of initial assignment and at least annually thereafter, the employer shall instruct **every** employee in safe operation and servicing of all equipment with which the employee is, or will be involved" (*per Federal Occupational Safety and Health Standards for Agriculture Subpart D, Section 1928.57 (a) (6)*)
3. Complete sign off sheet below to document training.
4. A person who has not read and understood all operating and safety instructions, is not qualified to operate this machine.
5. It is the responsibility of the owner, qualified operator/s or supervisor/s to see that no unqualified persons are allowed to operate this machine and that unqualified persons (*especially children*) stay out of the work area.



As a requirement of OSHA, it is necessary for the employer to train the employee in the safe operation and servicing of this machine at the time of initial assignment and at least annually thereafter. Use this sign off sheet to document training.

Date	Employer Signature	Employee Signature

# ASSEMBLY INSTRUCTIONS

1. Remove tongue (1) assembly from shipping skid.
2. Fasten tongue (1) to axle (3) and to spreader box (2) using provided 5/16" fasteners(A) and 3/8" fasteners(B).

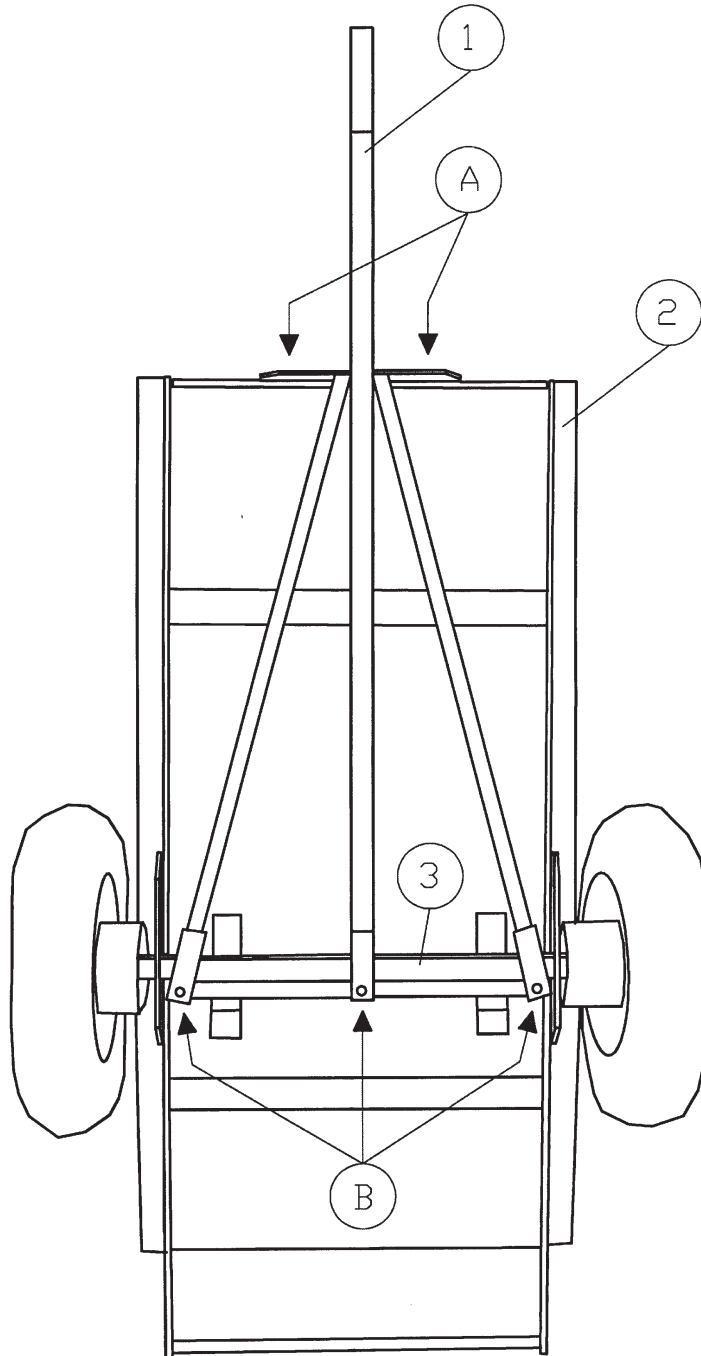

3. Unbolt lag screws which secure shipping skid to spreader.
4. Use overhead hoist to lower spreader to ground. **NOTE:** Spreader weighs 385 lbs.

# SAFETY & ACCIDENT PREVENTION

## CAUTION

### SAFETY FIRST—DO NOT OPERATE SPREADER WITHOUT READING ALL SAFETY DECALS

T.R. Metal Crafters, Inc. has taken the operator's safety into consideration when designing this spreader, by covering exposed moving parts for protection. However, in order to assure proper operation, some areas cannot be guarded or shielded. The safety alert symbol below indicates a hazard.

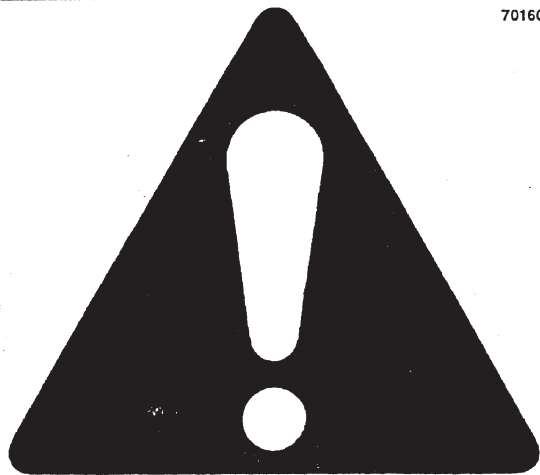

**BE ALERT!  
YOUR SAFETY IS INVOLVED!**

### A SPREADER CAN BE HAZARDOUS IN THE HANDS OF AN UNFAMILIAR, UNTRAINED OR CARELESS OPERATOR

Do not operate, service, inspect nor otherwise handle this unit without reading the Owner's and Operator's Manual completely and being familiar with the operation of this machine. If the Owner's and Operator's Manual is missing, contact T.R. Metal Crafters Co., Inc., P.O. Box 248, Loyal, WI 54446 (phone 1-800-842-5349)

1. Do not load rocks, metal nor other items, that could become dangerous flying objects during unloading.
2. Be sure spreader has been cleared of tools and is safely distanced from people before operating.
3. Never start the machine until all safety shields are secured in place.
4. If shields or decals become damaged or lost, contact dealer or factory for free replacement.
5. Do not wear loose nor floppy clothing, which may become entangled in spreader.
6. Do not step nor ride on spreader while it is moving.
7. Never get off tractor while it and/or spreader is moving.
8. Operate spreader at 3-5 mph. Use slow-moving-vehicle sign when required.
9. Avoid steep inclines, large rocks, stumps & holes.

## DANGER



**NO STEP – NO RIDERS  
Stay Clear!**



## DANGER



70161

### EXPOSED APRON CHAIN & ROTATING BEATER

Keep hands, feet, hair & clothing away from apron chain & rotating beater.

- Do not unplug, adjust, clean, service nor repair machine while it is moving. Apron chain or beater could accidentally become engaged.
- Disengage apron chain & beater, block wheels, and disconnect from power source, before adjusting or servicing.
- Do not step, climb, stand nor ride on machine while it is moving.
- Point discharge away from people, animals and buildings, before engaging.

## WARNING



70162

### MOVING PARTS CAN PINCH, CRUSH OR DISMEMBER Do not operate without all shields in place.

- Keep hands, feet, hair and clothing away from moving parts.
- Do not unplug, adjust, clean, service nor repair machine while it is moving. Beater or apron chain could accidentally become engaged.
- Disengage beater & apron chain, block wheels, and disconnect from power source, before adjusting or servicing.

# OPERATING INSTRUCTIONS

## HOOK-UP INSTRUCTIONS

1. Tractor must be 10 HP minimum, with a hitch approx. 10" above the ground.
2. Shut off tractor and set parking brake, before attaching onto spreader.
3. Move **APRON-CHAIN LEVER** and **BEATER LEVER** to "**OFF**" position.
4. Attach manure spreader hitch to tractor hitch, using a 5/8" hitch pin that will not bounce out.

## FILL-UP INSTRUCTIONS

1. Make sure **APRON-CHAIN LEVER** and **BEATER LEVER** are in "**OFF**" position.
2. Make sure no chunks of manure are frozen to spreader floor.
3. Make sure apron chain is not frozen to spreader floor.
4. Load spreader from front toward back for easier unloading.
5. Do not fill spreader above side panels.
6. Do not pack manure against beaters.
7. Do not load string nor wire. They can wind onto beater while unloading.

## SPREADING INSTRUCTIONS

1. Shut off tractor and set parking brake.
2. Move **APRON-CHAIN LEVER** and **BEATER LEVER** to "**ON**" position.
3. Start tractor and begin moving forward.
4. Operate spreader at 3-5 mph.
5. Do not operate spreader over 5 mph.
6. Do not back up spreader when it is in unloading mode, to avoid damage.
7. When done unloading, shut off tractor and set parking brake.
8. Move **APRON-CHAIN LEVER** and **BEATER LEVER** to "**OFF**" position.
9. Clean manure from cracks and corners, to increase life of spreader.

Spread *into* the wind, especially when strewing heavy, mucky loads. Clods of soggy manure sometimes cling to beaters . . . and can spray back toward driver.

"3-5 mph" (*needed to obtain desired spreading action*) = a **comfortable** walking pace

"over 5 mph" (can cause premature wear or damage) = a **very-brisk** walking pace

70166



Disengage apron chain & beater, block wheels, and disconnect from power source, before adjusting or servicing.

Always replace guards before operating manure spreader. If guards or decals become damaged or lost, contact dealer or factory for free replacements. *Failure to heed these instructions could result in severe personal injury or death.*

## GENERAL MAINTENANCE

- Check the spreader each time it is used for loose, bent, broken or missing parts. During operation, listen for abnormal sounds which might indicate loose parts or other damage. Correct any problems immediately.
- Rinse manure out of the spreader after each use to prevent rust and avoid winter freezedown.

## LUBRICATING INSTRUCTIONS

As with any type of equipment, the life of the unit is dependent upon the lubrication care given by the operator. Lubrication should be done at regular intervals to avoid premature failure.

### **Bearing, Sprocket & Chain Lubrication:**

Grease bearings and sprockets after every 6-hours of use and just before storage (*with a multi-purpose grade of grease*).

Grease lube fittings until grease begins to seep from fittings.

Replace fittings when they will not take grease (*all lube fittings are SAE standard*).

Six locations require greasing  
(marked by "6 hr." grease decals).

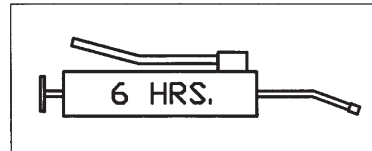

Lubricate apron chain and roller chain with chain lube or motor oil once a month. Lubrication will reduce friction, quiet spreader and greatly extend chain life.

## ADJUSTMENT INSTRUCTIONS

### **Apron-Chain Tension:**

- 1) Pull up on the floor apron-chain flight at center of the spreader box length.
- 2) If you can lift the bottom of flight higher than 2", the chain is too loose (*which can cause premature chain and sprocket wear*).
- 3) If you can not lift the bottom of flight at least 2", the chain is too tight (causing excessive loads on all components).
- 4) To adjust the apron-chain tension, use the 3/8 x 6" tension bolts on each side of the front apron shaft.
- 5) **Check that chains on each side of apron are equally taut.**

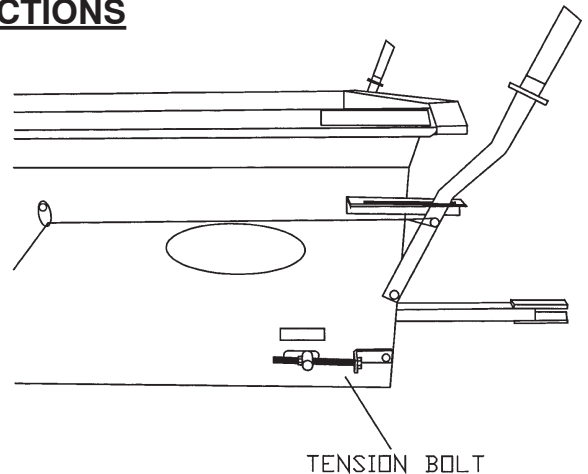

### **Cam Arm Pulley:**

Check alignment of cam arm pulley with cam. Cam should align with center of pulley.

### **Fasteners:**

Tighten all fasteners after approximately 10-hours of use. This should include all bolts, nuts and set screws. Periodically tighten all fasteners to prevent elongation of holes and premature component failure.

**Latch Adjustment:**

*Symptom:* Apron chain is not moving

*Problem:* Improper latch adjustment

*Solution:* Adjust latch as follows.

- 1) Raise left drive wheel off the ground
- 2) Remove crank-arm guard
- 3) Turn left drive wheel by hand, while checking latch (5) engagement into the sprocket tooth (6)
- 4) Loosen-lightly the four 5/16" lock nuts (4) which attach latch bracket (3) onto spreader-box side
- 5) With roller (2) positioned on highest point of ratchet cam (1), tap the latch bracket (3) ahead or back as necessary to attain 3/32" to 1/8" of clearance between the latch (5) and the sprocket tooth (6). See illustration below.
- 6) Re-tighten the four 5/16" lock nuts (4) that attach latch bracket (3) onto spreader-box side
- 7) Re-install crank-arm guard

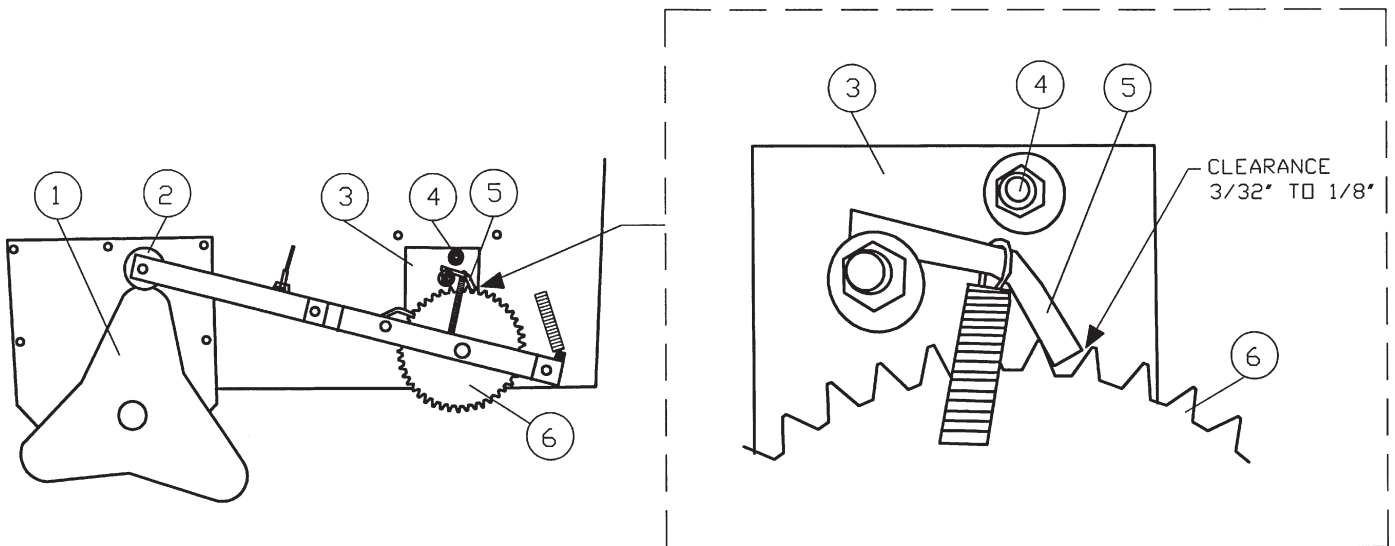
**Cold Weather Instructions**

- Manure can be spread in cold weather, although snow and ice may affect the spreader wheel traction required for good spreading action (because the cleated spreader wheels drive the apron chain and the beater).
- While manure should not be stored in the spreader, it must not be stored in the spreader during freezing weather. Frozen manure could result in severe equipment damage, such as breaking the floor apron chain.
- Store spreader under cover in freezing weather. Exposure to snow and ice can cause the mechanisms to freeze and not operate properly, and they may break under the stress.

# Limited Warranty

T.R. Metal Crafters, Inc. warrants this unit to be free from breakage or malfunctions due to defects in material and/or workmanship under normal farm use and service, for a period of **one-year** from date of original sale. Should such breakage occur within warranty period, the liability of T.R. Metal Crafters, Inc., its employees, agents, authorized distributors, and dealers (hereinafter collectively referred to as sellers) is hereby expressly limited to repairing or, at its option, replacing free of charge at its factory, any part or parts found upon examination by factory to be defective in material or workmanship or both; this is the exclusive remedy. The purchaser is responsible for transportation cost of the equipment for warranty service or for any service call expense. Sellers liability is further expressly limited with respect to components manufactured by others, such as, but not limited to tubes, tires, bearings, detachable link and roller chains, or other trade accessories; to the extent of such warranties as are extended to sellers by these manufacturers. This warranty shall apply only within the boundaries of the continental United States.

Notice of defect shall be furnished in writing to the Seller and to the agent through whom the unit was purchased, disclosing in full all known defects and failure in operation and use. Reasonable time shall be given to the Seller to remedy any such defects and failures.

This warranty is in lieu of all other warranties, expressed (except as set forth within) or implied, including but not limited to warranties of merchantability and fitness for a particular purpose. Manufacturer makes no warranty as to the design, capability, capacity, nor suitability for use of the unit. The obligation and liability of sellers under this warranty does not extend to loss of crops, loss because of delay in harvesting or any expense or loss incurred for labor, supplies, substitute machinery or rental machinery, transportation, or other charges.

Except as provided herein, manufacturer shall have no liability or responsibility to purchaser or any other person or entity with respect to any liability, loss, or damage caused or alleged to be caused directly or indirectly by the unit including, but not limited to, any indirect, special, consequential, or incidental damages resulting from the use or operation of the unit or any breach of this warranty. Notwithstanding the above limitations and warranties, manufacturer's liability hereunder for damages incurred by purchaser or others shall not exceed the price of the unit.

T.R. Metal Crafters, Inc., reserves the right to make changes in design and components or material or to utilize available materials which it deems satisfactory, in order to improve its products. Also, T.R. Metal Crafters, Inc. reserves the right to make changes in the construction or design of any parts without incurring any obligations to install these improvements or changes on previously delivered units.

This warranty shall be void if any part or parts not manufactured or supplied by T.R. Metal Crafters, Inc., are used either in servicing or maintaining the unit, and sellers obligation to repair or replace parts are then voided. This warranty shall be void if in the judgement of T.R. Metal Crafters, Inc., repairs are made in such a manner to affect this unit in a materially adverse manner or if this unit is operated unsafe or while in a state of disrepair. This warranty shall be void if equipment is used for commercial, industrial, lease, rental, custom operation and non-agricultural use. Any damage to this product as a result of misuse, abuse, neglect, accident, improper installation, alteration, repairs (not out own), improper adjustment, accident, damage by fire, act of God, lack of performing required maintenance or any other use contrary to our instructions will void the warranty. This warranty will be void if the product serial numbers are altered, defaced or removed.

If any provision of this limited warranty shall violate any applicable law and is held to be unenforceable, then the invalidity of such provision shall not invalidate any other provisions herein. Applicable law may provide rights and benefits to purchaser in addition to those provided herein.

The terms and conditions of this warranty cannot be altered, modified, or waived by any seller without the expressed, written consent of an officer of T.R. Metal Crafters, Inc.

## Notice

T.R. Metal Crafters, Inc., disclaims any liability for the operation of the equipment with the safety shields removed or modified. The nature of this product require that it be operated in a safe way only, and in good repair by qualified persons. Each purchaser, through the process of purchasing this equipment, agrees with T.R. Metal Crafters, Inc., to operate it in a safe manner and in accordance with applicable state and federal laws and agrees to indemnify and hold harmless sellers, from any loss to any person or persons caused by purchaser's failure to do so. Each purchaser further agrees to bring to the attention this notice to each subsequent purchaser, and to obtain his agreement thereto as a condition of resale or transfer.

## Important

To make this warranty effective, the Owners "Warranty Registration" card (located inside Owners/Operator's Manual) must be filled out and sent to T.R. Metal Crafters, Inc. within 30-days of purchase.

Model MS23B

**DRIVE AND APRON**

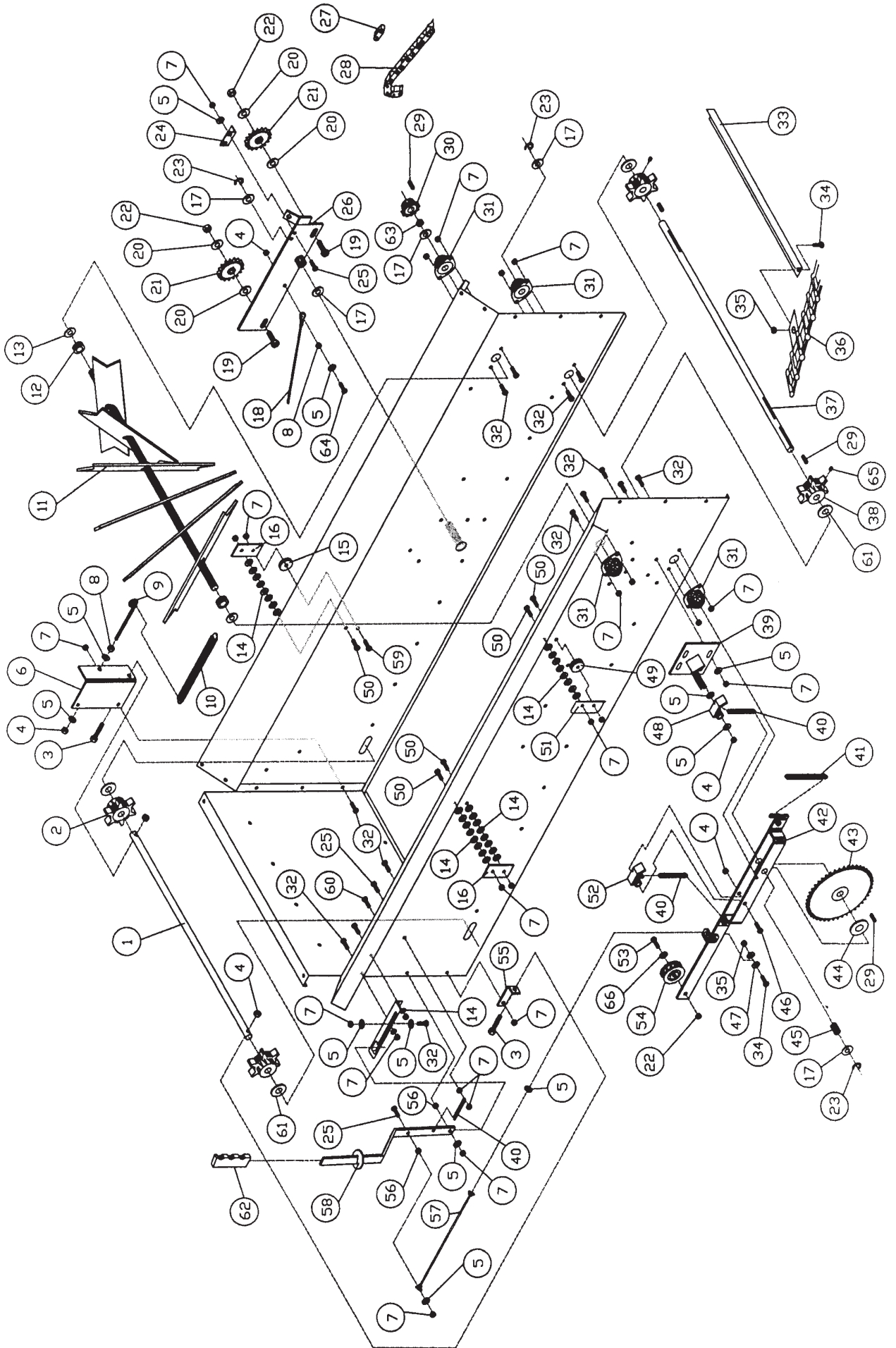

# Loyal Manure Spreader Parts Manual

## Model MS23B

### DRIVE and APRON

Key No.	Description	Qty.	Item No.	Key No.	Description	Qty.	Item No.
1	Shaft, Apron (Front)	1	70183	*34	Hex Head Cap Screw — 1/4"-20 x 3/4", Grade 5, Plated	20	F1072245
2	Sprocket with Bushing — 6-Tooth x No. 55	2	70274	*35	Nut, Nylon-Insert Lock — 1/4"-20, Grade 2, Plated	21	F356030
*3	Hex Head Tap Bolt — 3/8"-16 x 6", Grade 5, Plated	2	F108670	36	Chain with Attachment less Flight — No. 55 x 10' Pair	1	T0356
*4	Nut, Nylon-Insert Lock — 3/8"-16, Grade 2, Plated	6	F356050	37	Shaft, Apron (Rear)	1	70184
*5	Washer, Standard Flat — 5/16", Plated	19	F808030	38	Sprocket with Key — 6-Tooth x No. 55	2	70265
6	Bracket, Chain Tensioner (Right)	1	70298	39	Bracket, Latch	1	70255
*7	Nut, Nylon-Insert Lock — 5/16"-18, Grade 2, Plated	32	F356040	40	Spring, Extension — 7/16" x 3"L, Plated	3	JN97080
*8	Nut, Hex — 3/8"-16, Grade 2, Plated	3	F354050	41	Spring, Extension — 5/8" x 5-1/2"L, Galvanized	1	JN97082
9	Bolt, I — 3/8"-16 x 7" Long x 3/8" I.D., Grade 2, Plated	1	F103030	42	Arm, Crank	1	71291
10	Spring, Extension — 1" x 15"L, Plated	1	JN100907	43	Sprocket, Crank Arm	1	70268
11	Agitator	1	70260	*44	Washer, Standard Flat — 3/4", Unplated	1	F808078
12	Collar, Shaft — 3/4" ID, Plated	2	12523	45	Spacer, Rear Shaft	1	70310
13	Washer, Copper — .125" x .766" x 1.375"	2	70291	*46	Hex Head Cap Screw — 3/8"-16 x 2-1/2", Grade 5, Plated	1	F1072485
*14	Washer, SAE Flat — 5/16", Plated	34	F807040	*47	Washer, Standard Flat — 1/4", Plated	2	F808020
15	Pulley, Cable Guide	1	70302	48	Latch, Crank Arm	1	70258
16	Plate, Cable Guide	2	70314	49	Guide, Cable	1	70317
17	Bushing, Machine — 18 Gauge x 3/4" x 1-1/4", Unplated	5	F806030	*50	Hex Head Cap Screw — 5/16"-18 x 1-1/4", Grade 5, Plated	5	F1072350
18	Cable, Agitator	1	70245	51	Plate, Cable Guide	1	70318
*19	Bolt, Carriage — 1/2"-13 x 2", Grade 2, Plated	2	F101060	52	Pawl, Ratchet Crank Arm	1	70257
*20	Washer, Standard Flat — 1/2", Plated	4	F808050	*53	Hex Head Cap Screw — 1/2"-13 x 2", Grade 5, Plated	1	F1072655
21	Sprocket, Idler — 4017 x 1/2" ID	2	04017E08	54	Pulley with Bushing and Bearing, Idler, .5" ID x 2.5" OD	1	71288
*22	Nut, Nylon-Insert Lock — 1/2"-13, Grade 2, Plated	3	F356060	55	Bracket, Chain Tensioner (Left)	1	70264
*23	Ring, E-Retaining — .05" x 5/8" x 1.12", Unplated	3	F503020	*56	Nut, Hex — 5/16"-18 Grade 2, Plated	4	F354040
24	Guard, Chain Carrier	1	70222	57	Cable, Apron	1	70244
*25	Hex Head Cap Screw — 5/16"-18 x 1", Grade 5, Plated	3	F1072345	58	Handle, Engagement	2	70263
26	Bar, Chain Carrier	1	70256	*59	Hex Head Cap Screw — 5/16"-18 x 1-1/2", Grade 5, Plated	1	F1072355
27	Link with Pin and Clip, Roller Chain — No. 40	1	N0401	*60	Hex Head Tap Bolt — 5/16"-18 x 1-1/2", Grade 5, Plated	2	F108621
28	Chain with Link, Roller — No. 40 x 168 Pin	1	70170	*61	Washer, SAE Flat — 12 Gauge x 49/64 I.D. x 1-1/2" O.D.	4	F807030
*29	Key, Square — 3/16" x 3/16" x 1", Unplated	4	F203020	62	Handle Grip, Red	2	40006250734
30	Sprocket with Key and Screw — No. 40 x 12-Tooth x 3/4"	1	40BS12H-3/4	63	Spacer, Agitator Shaft	1	70320
31	Bearing, Flange — 2-Hole, 3/4" ID	4	FAH12G	*64	Hex Head Tap Bolt — 3/8"-16 x 1-1/4", Grade 5, Plated	1	F108630
*32	Hex Head Cap Screw — 5/16"-18 x 3/4", Grade 5, Plated	20	F1072340	*65	Socket Head Set Screw, Knurled Point — 5/16"-18 x 5/16"	2	F702035
33	Flight, Chain	10	70179	66	Washer, SAE Flat, 1/2", Plated	1	F807050

\* Also available from your local hardware store

 Do not substitute Grade 2 bolts when stronger Grade 5 bolts are specified.  
Failure to heed these instructions could result in serious personal injury or death!

**TONGUE AND AXLE  
MS23B**

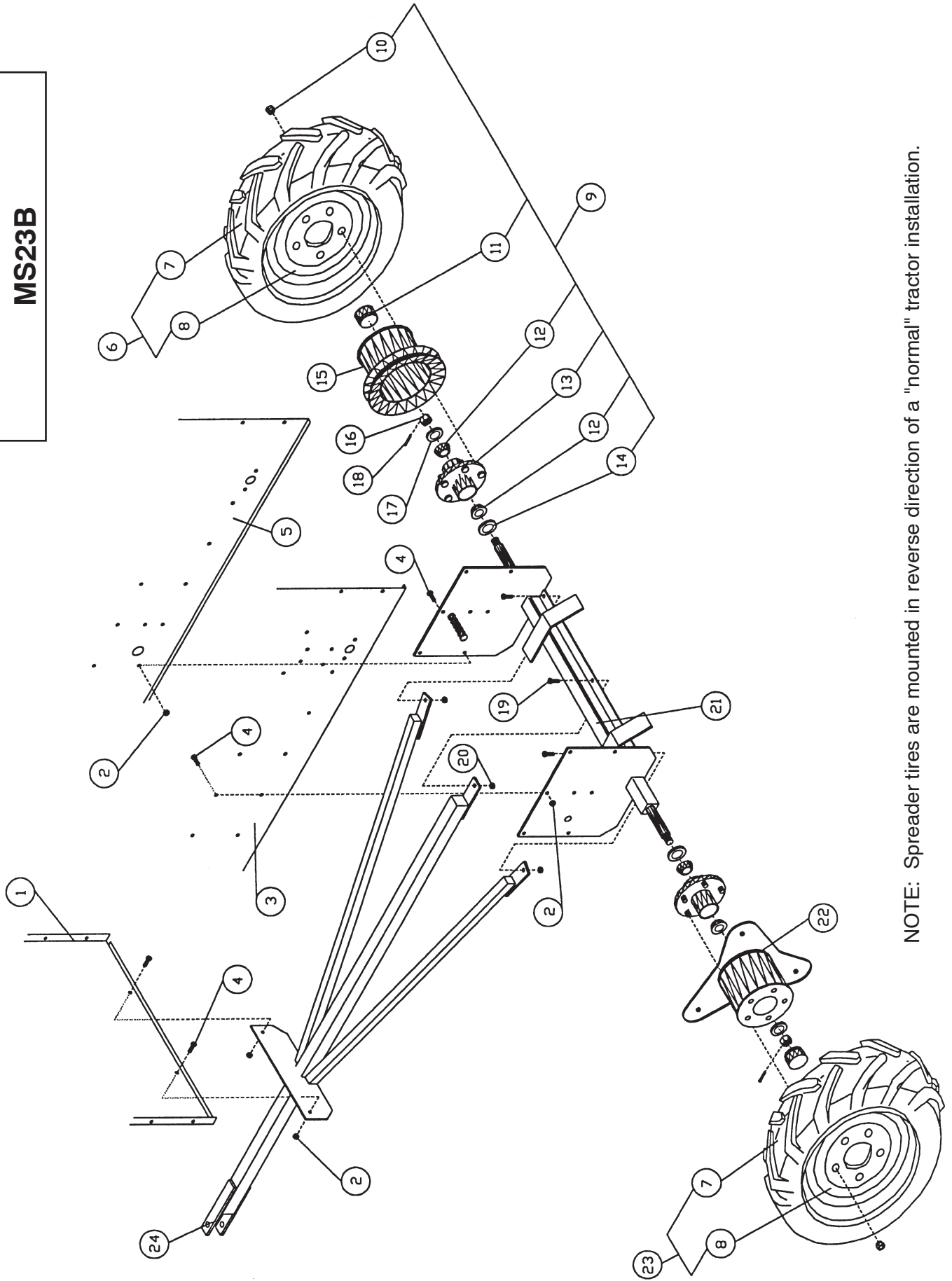

NOTE: Spreader tires are mounted in reverse direction of a "normal" tractor installation.



# Loyal Manure Spreader Parts Manual

## Model MS23B

### TONGUE and AXLE

Key No.	Description	Qty.	Item No.
1	Front with Decals, Box	1	70281
*2	Nut, Nylon Insert Lock — 5/16"-18, Grade 2, Plated	14	F356040
3	Side with Decals, Box (Left)	1	70283
*4	Hex Head Cap Screw — 5/16"-18 x 3/4", Grade 5, Plated	14	F1072340
5	Side with Decals, Box (Right)	1	70282
6	<b>Wheel with 6" x 12" Tire (Right)</b>	1	70306
7	Tire Only — 6" x 12"	1	70307
8	Wheel Only, 12" x 4" Plain	1	70308
9	<b>Hub with Bearings, Seal, Dust Cap and Nuts</b>	2	Order Components
*10	Nut, Wheel — 1/2"-20	10	1468900
11	Cap, Dust — 1-5/32"	2	1428600
12	Bearing, Cone — 1" No. L44643	4	0801800
13	Hub Only, A-Frame — 5 Bolt, 4.5" BC	2	1283200CB042
14	Seal, Grease — 1.25" ID x 1.983" OD	2	0899800
15	Hub, Agitator Drive	1	70254
16	Nut, Castle	2	10T5
*17	Washer, SAE Flat — 12 Gauge x 49/64" ID x 1.5" OD	2	F807030
*18	Pin, Cotter — 5/32" x 1" Plated	2	F403040
*19	Hex Head Cap Screw — 3/8"-16 x 1", Grade 5, Plated	3	F1072450
*20	Nut, Nylon Insert Lock — 3/8"-16, Grade 2, Plated	3	F356050
21	Frame, Middle	1	71293
22	Hub, Ratchet Cam	1	71294
23	<b>Wheel with 6" x 12" Tire (Left)</b>	1	70305
7	Tire Only — 6" x 12"	1	70307
8	Wheel Only, 12" x 4" Plain	1	70308
24	Tongue	1	70259

\* Also available from your local hardware store



**Do not substitute Grade 2 bolts when stronger Grade 5 bolts are specified.**  
**Failure to heed these instructions could result in serious personal injury or death!**

**FRAME AND GUARD  
MS23B**

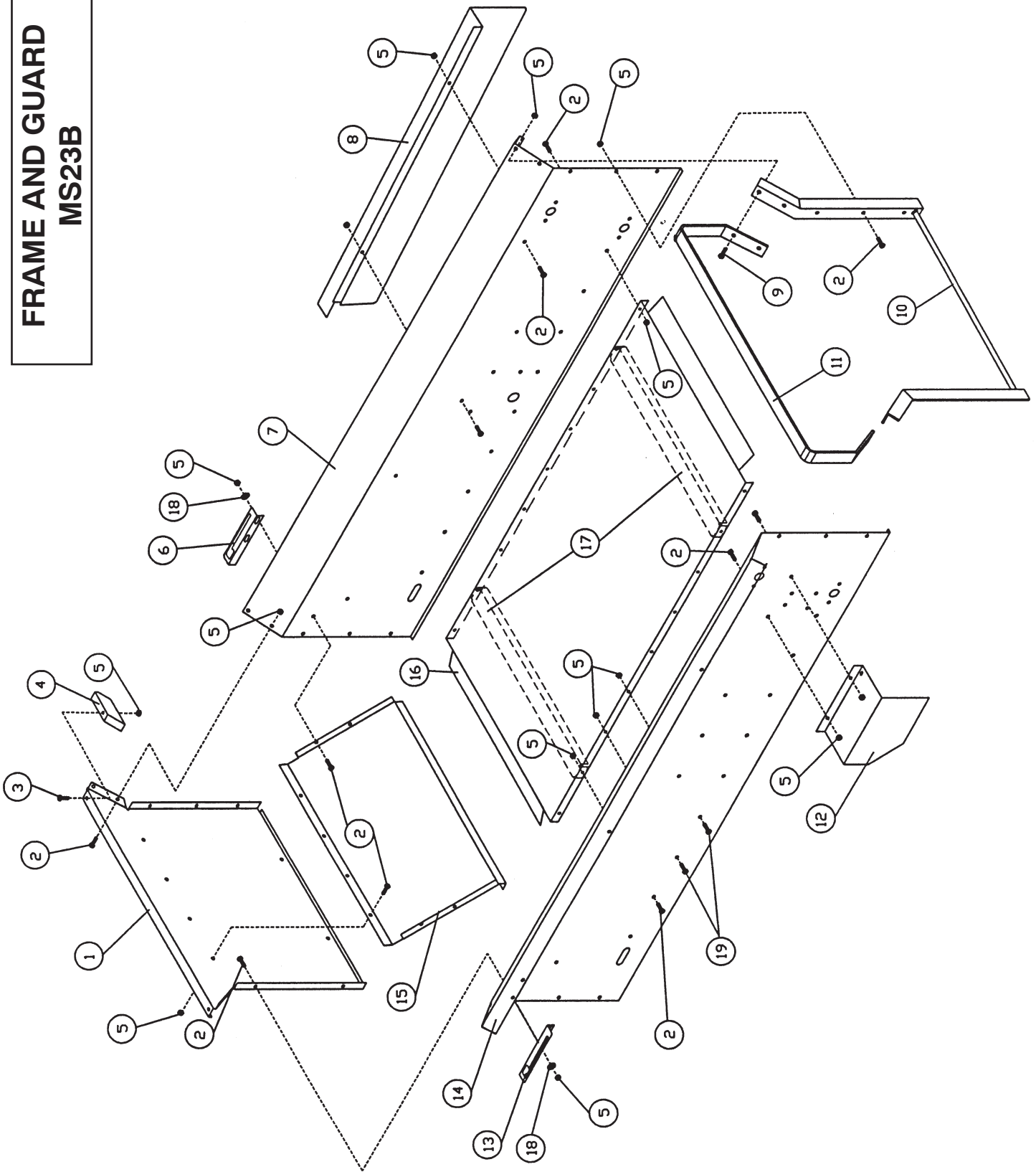

# Loyal Manure Spreader Parts Manual

## Model MS23B

### FRAME and GUARD

Key No.	Description	Qty.	Item No.
1	Front with Decals, Box	1	70281
*2	Hex Head Cap Screw — 5/16"-18 x 3/4", Grade 5, Plated	32	F1072340
*3	Hex Head Cap Screw — 5/16"-18 x 2", Grade 5, Plated	2	F1072360
4	Protector, Front Corner	2	70236
*5	Nut, Nylon-Insert Lock — 5/16"-18, Grade 2, Plated	42	F356040
6	Bracket, Engagement Handle (Right)	1	70182
7	Side with Decals, Box (Right)	1	70282
8	Guard with Decals, Chain	1	70284
*9	Hex Head Cap Screw — 5/16"-18 x 1", Grade 5, Plated	4	F1072345
10	Guard, Agitator (Bottom)	1	70261
11	Guard, Agitator (Top)	1	70262
12	Guard, Crank Arm	1	70250
13	Bracket, Engagement Handle (Left)	1	70181
14	Side with Decals, Box (Left)	1	70283
15	Baffle, Front	1	70176
16	Bottom, Box	1	70177
17	Support, Box Bottom	2	70178
18	Washer, SAE Flat — 5/16", Plated	4	F807040
19	Hex Head Cap Screw — 5/16"-18 x 1/2", Grade 5, Plated	4	F1072315

\* Also available from your local hardware store



**Do not substitute Grade 2 bolts when stronger Grade 5 bolts are specified.  
Failure to heed these instructions could result in serious personal injury or death!**



# **WARNING**

**Read and Understand this manual  
*Before Operating***

**FAILURE TO HEED COULD RESULT IN PERSONAL INJURY OR DEATH**