



Stainless Steel Playtop Home PARTS LIST

Instructions online at www.prevuepet.com

CUSTOMER SUPPORT

For assistance or replacement parts, please contact Prevue Pet Products:

PHONE 1 (312) 243-3624

ONLINE www.prevuepet.com

EMAIL customerservice@prevuepet.com

HARDWARE INCLUDED:

 Phillips-head screws
30 pcs (installed in place on cage panels) *

 Hex screws
4 pcs (installed in place on playtop supports)

 Knobs
4 pcs (installed in place on cage & playtop bar)

 **C**
Casters
4 pcs

* (plus 2 bagged extras)

TOOLS INCLUDED:

Allen wrench



TOOLS NOT INCLUDED:

Phillips-head screwdriver

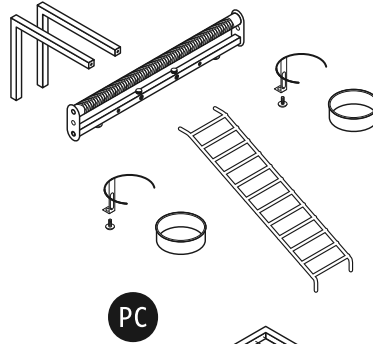
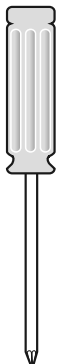

KEY:

- B = Back panels
- LS = Left Side panels
- F = Front panels
- RS = Right Side panels
- R = Roof grille
- C = Casters
- PC = Playtop Components
- CC = Cage Components

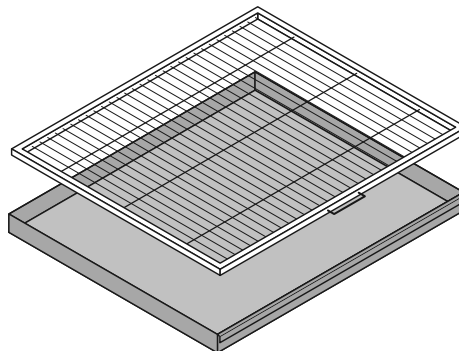
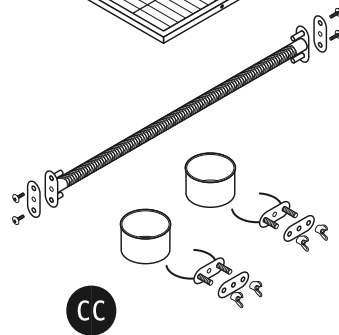
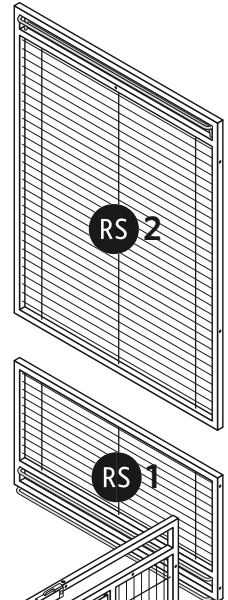
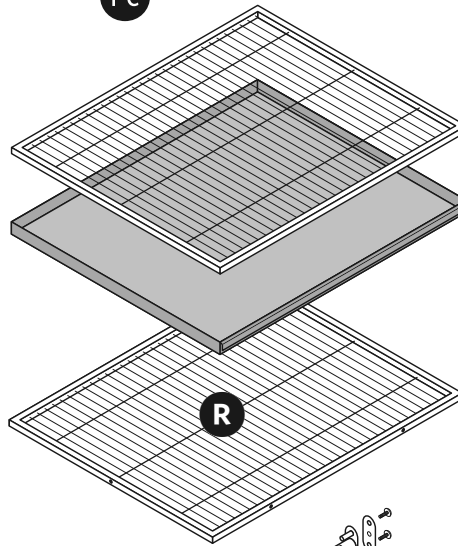
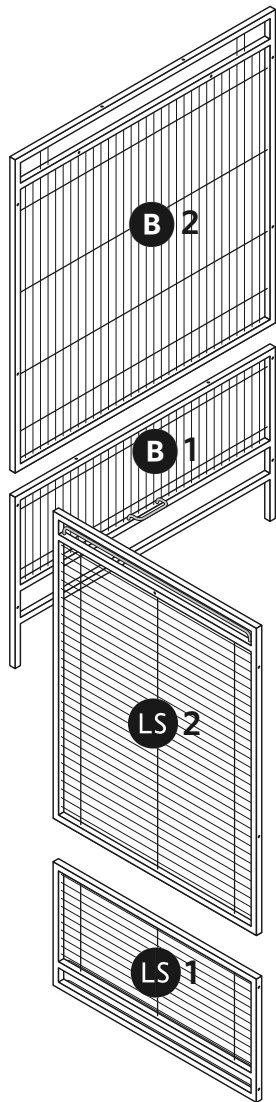



MODEL #
3455

Stainless Steel Playtop Home

Instructions online at www.prevuepet.com

CUSTOMER SUPPORT

For assistance or replacement parts, please contact Prevue Pet Products:

PHONE 1 (312) 243-3624

ONLINE www.prevuepet.com

EMAIL customerservice@prevuepet.com

TOOLS NEEDED : Phillips head screwdriver • For best results, follow Assembly Steps in order presented.

KEY:

B = Back panels	R = Roof grille
LS = Left side panels	C = Casters
F = Front panels	PC = Playtop Components
RS = Right side panels	CC = Cage Components

* In most cases, we recommend two people assemble this cage. 

* Screws are installed in place. When attaching panels or components, back the screw out, match up the components, and reinsert to attach.

1 PIECES

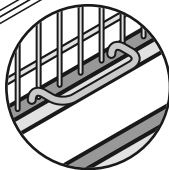
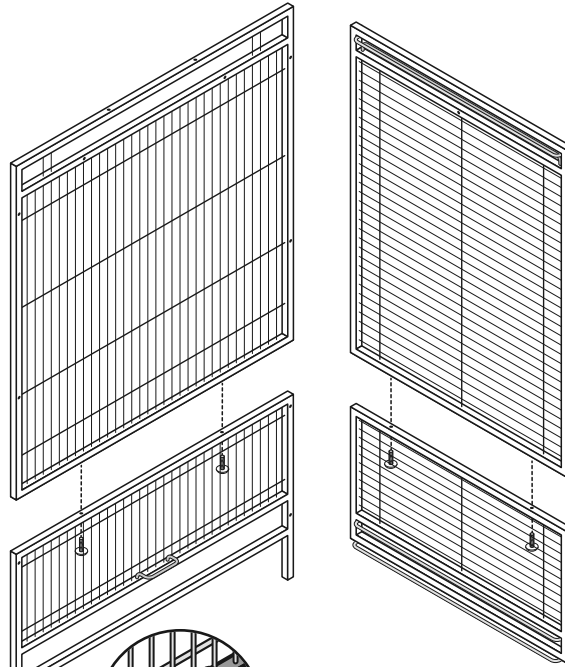
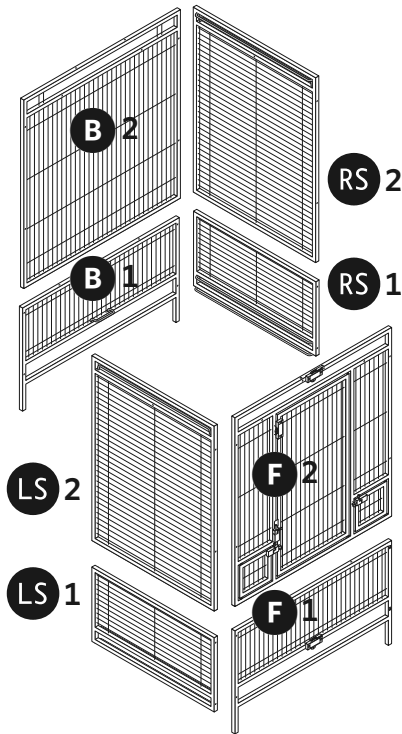

Note: Small loop on the back panel should face the interior. This loop helps hold the bottom grille in place.

Back the Phillips-head screws out, align the **upper panel** with the **lower panel** and retighten the screws to attach.

Grille/tray tracks on all side panels should be on the same side, facing the interior.

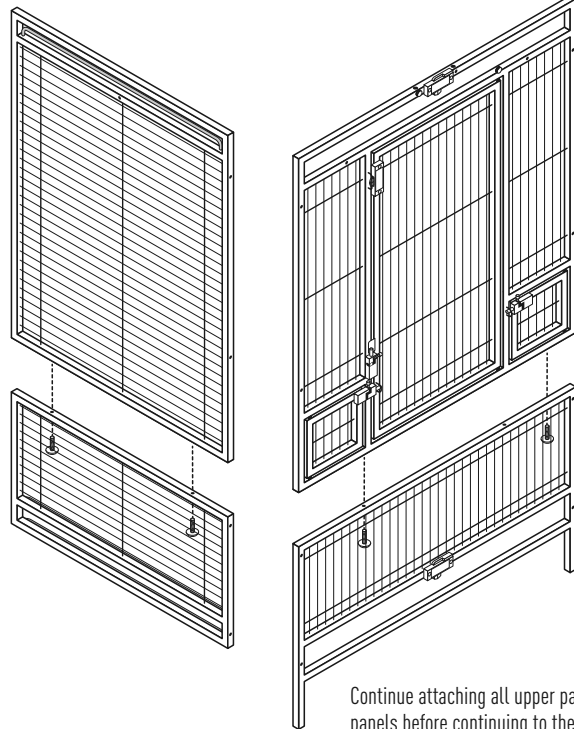

Continue attaching all upper panels to lower panels before continuing to the next step.

2 PIECES

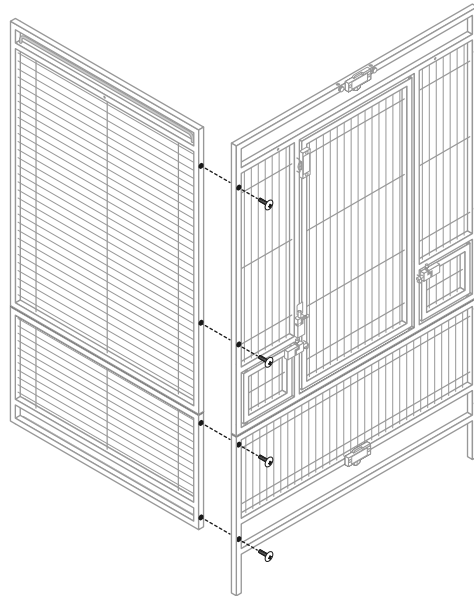
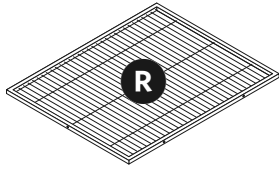

Back the Phillips-head screws out, align the side panel unit with the front panel unit, and re-tighten the screws to attach.

Repeat this method for all panel units to assemble the cage body.

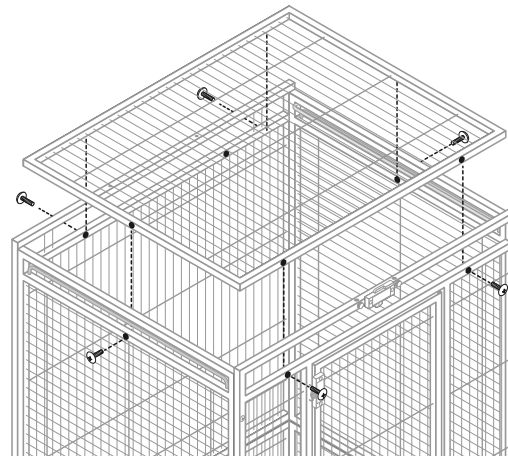
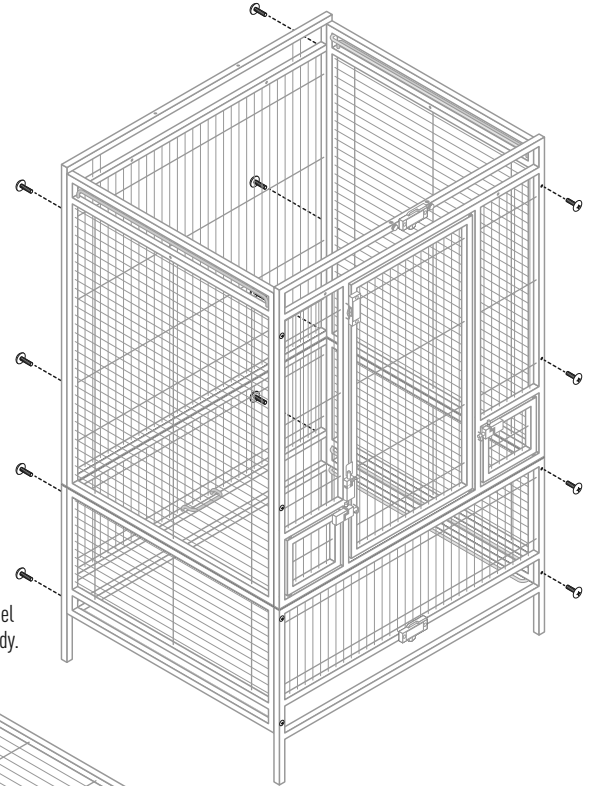

Set the cage roof grille in position and attach with Phillips-head screws.

3 PIECES

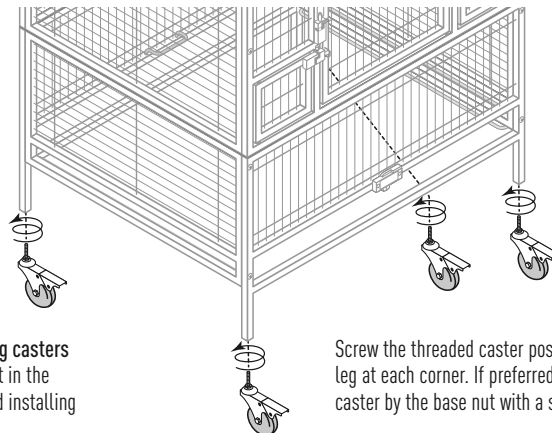
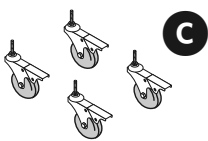

While the lockable rolling casters can be added at any point in the assembly, we recommend installing them at this time.

Screw the threaded caster post into the frame leg at each corner. If preferred, tighten each caster by the base nut with a slim wrench.

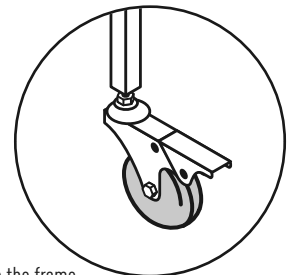

4 PIECES

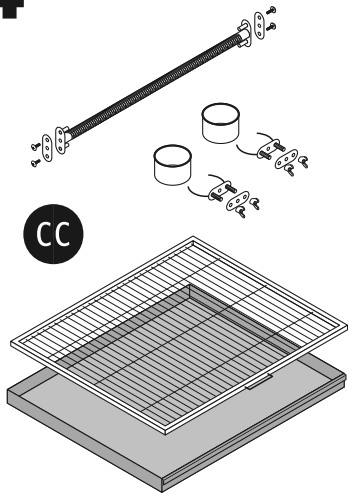

Perch:

Hold the perch in place in the cage interior. Install a Phillips-head screw through the bracket, through the cage wire, into the perch bracket and tighten with a Phillips screwdriver for all four screws.

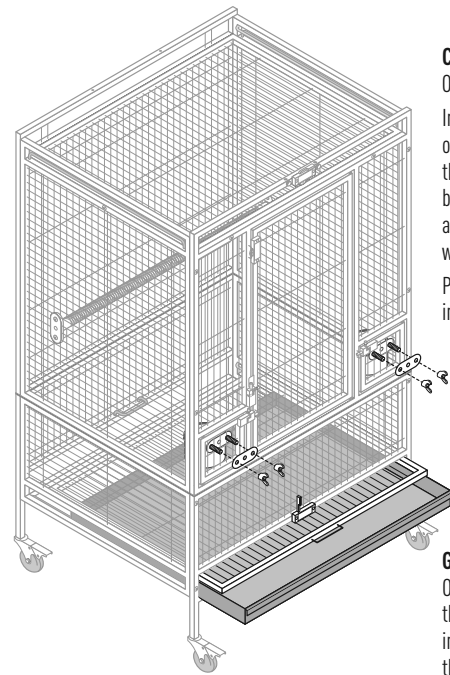
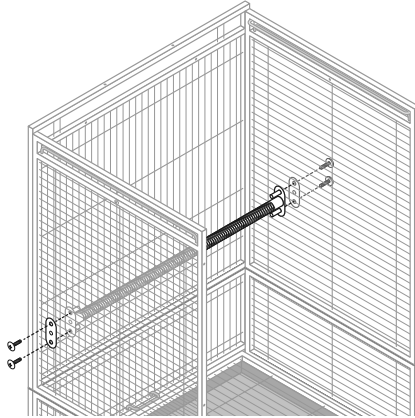

Cups/cup holders:

Open the cup door.
Insert the screw posts on the cup holder through the door mesh, add the bracket on the outside, and tighten to the doors with the wing nuts.
Place the **deep cups** into the holders.

Grille and tray:

Open the grille lock. Slide the **grille (with handle)** into the top channel and the **deep tray** into the bottom channel.

5 PIECES

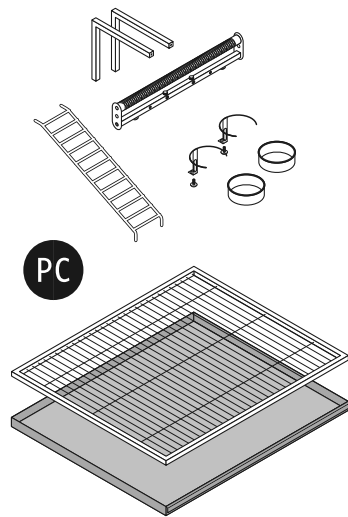

Remove the hex screws from the ends of the perch bar supports. Install the **perch bar supports** on the back panel of the cage.

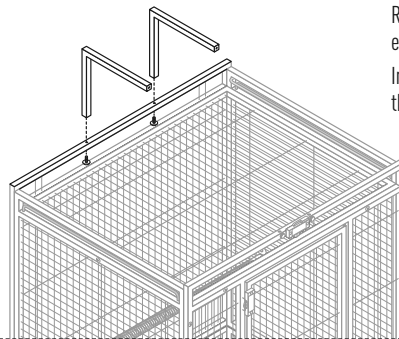

Back the Phillips-head screws on the underside of the perch bar and attach the cup holders.

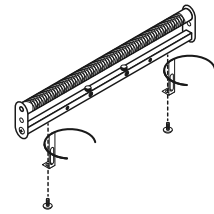

Attach the perch bar to the support rails using the hex screws and the allen wrench. Insert the **shallow cups**.
Open the grille lock. Slide the **thin grille** into the top channel and the **shallow tray** into the bottom channel.

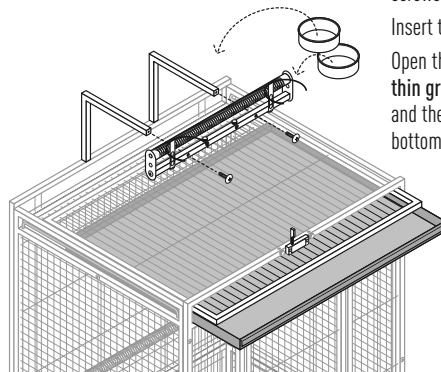

Loosen the knob screws on the perch bar rail and along the cage front. Insert the **ladder** and re-tighten the knob screws.

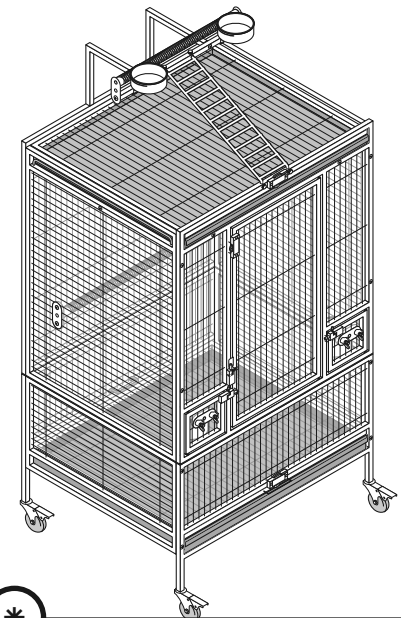
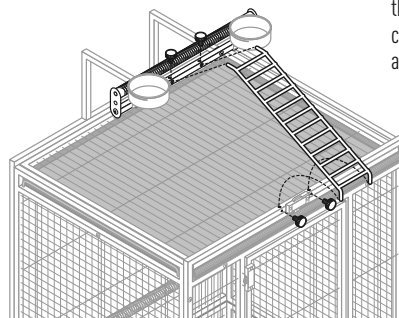

***** When fully assembled, check and tighten ALL screws and wing nuts over the entire cage to ensure a safe and stable home.

Assembly completed. ■