



POWERSPORTS

## CAUTION

THIS GO KART WAS SHIPPED WITHOUT ENGINE OIL. ALWAYS FILL WITH THE CORRECT AMOUNT AND GRADE OF ENGINE OIL AS LISTED IN THE OWNER'S MANUAL

# ASSEMBLY/PRE-RIDE INSPECTION INSTRUCTIONS

**KT196**

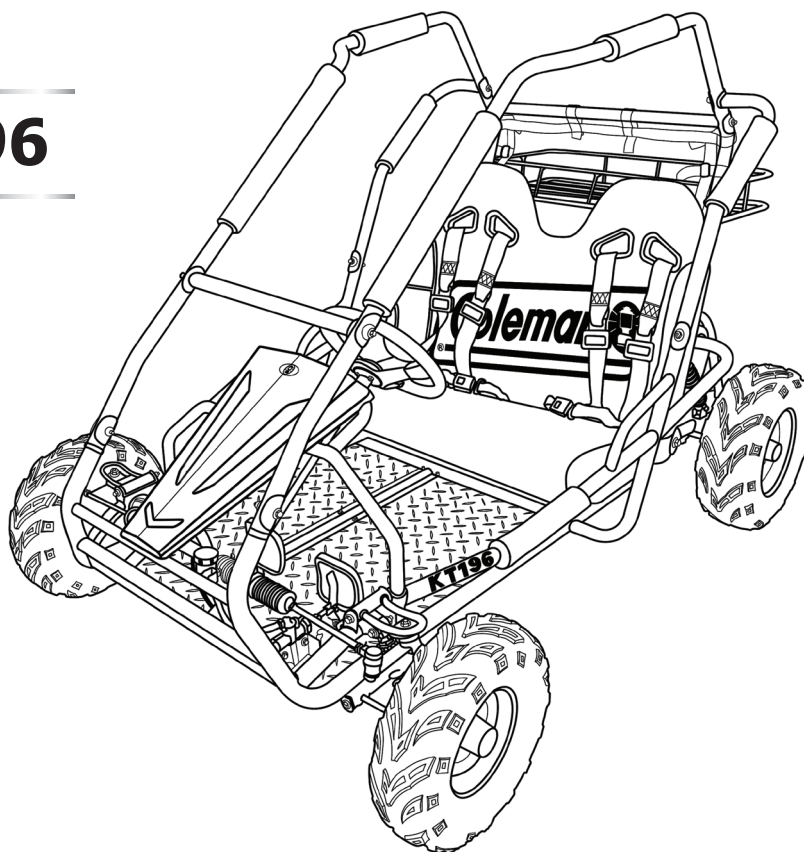

FOR QUESTIONS ABOUT THESE ASSEMBLY INSTRUCTIONS,  
CALL COLEMAN POWERSPORTS 888-405-8725

## **⚠️ WARNING**

NEVER ATTEMPT TO START THIS GO KART WITHOUT READING AND UNDERSTANDING THE OWNER'S/ OPERATOR'S MANUAL. THE OWNER'S OPERATOR'S MANUAL PROVIDES INFORMATION ON SAFETY, PARTS, FUNCTIONS, PRE-RIDE INSPECTION, STARTING AND MAINTENANCE

# REMOVAL FROM CRATE

1. Remove metal crate from around Go-Kart.

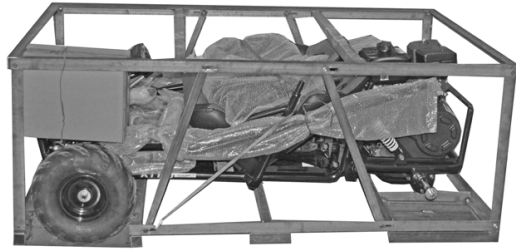

2. Locate and Remove Owner's/Operator's manual, Set up instructions and all documentation.

Note:

Read Owner's / Operator's manual thoroughly before starting Go-Kart for the first time.

3. Locate and remove all parts and hardware from crate and set aside.

Note: Some hardware may already be mounted at part locations on the Go-Kart. This hardware will need to be removed then re-attached during assembly.

## Wheel Parts



Rear Tires



Rubber Hub  
Caps

## Steering Wheel



SteeringWheel



Steering Wheel Cap

## Brush Guard Parts

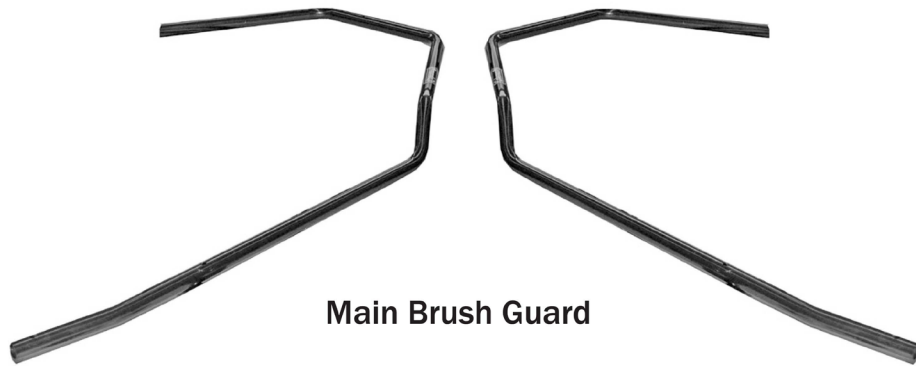

Brush Guard  
Cross Braces

Brush Guard  
Side Supports

## Rear Rack



# REAR WHEEL ASSEMBLY

Hardware:

- M12 Washer 2ea. (1)
- M12 Castle nuts 2ea. (2)
- Cotter pins 2ea. (3)

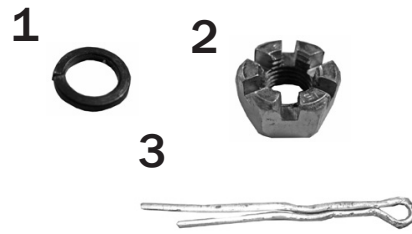

1. Install rear tires using M12 Washers (1), M12 Castle Nuts (2) and Cotter Pins (3)

Note: Make sure tire tread faces forward and Air valve stem is on the outside of the tire when installing.

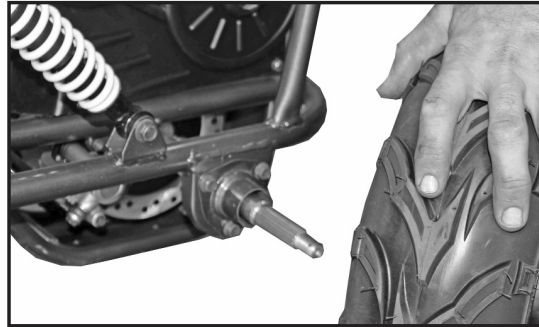

↑  
Tread  
faces  
1  
forward

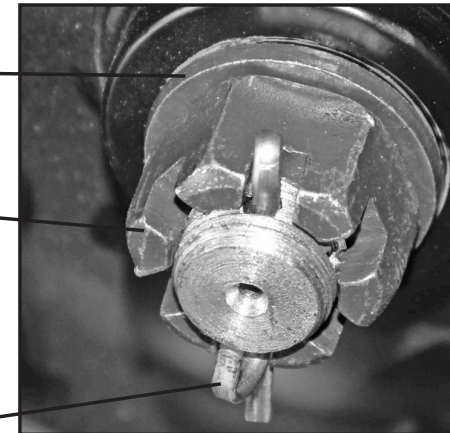
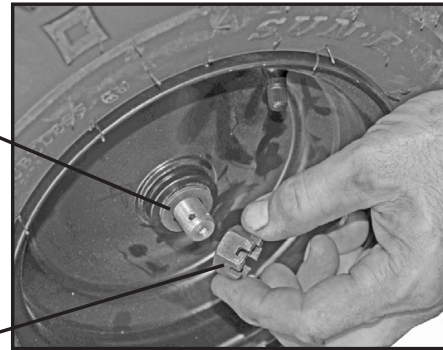

**⚠ WARNING**

Failing to install cotter pins could be hazardous.

Failing to install cotter pins could cause the castle nuts to fall off resulting in an accident.

Never operate Go Kart without cotter pins installed.

2. Install Hub Caps (4) by snapping on hub.

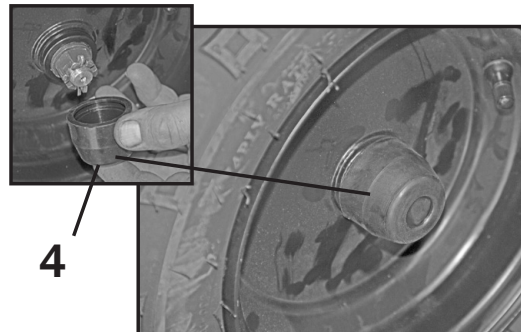

# STEERING WHEEL INSTALLATION

Hardware:

M6 x 16 bolts 3 ea. (1)

M6 Lock Nuts 3ea. (2)



1. Attach steering wheel using M6 bolts (1) and M6 lock nuts(2) .

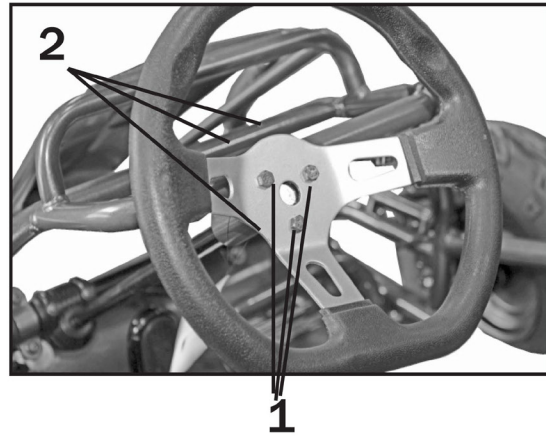

2. Attach steering wheel cap by snapping into place on center of steering wheel.

Steering Wheel Cap

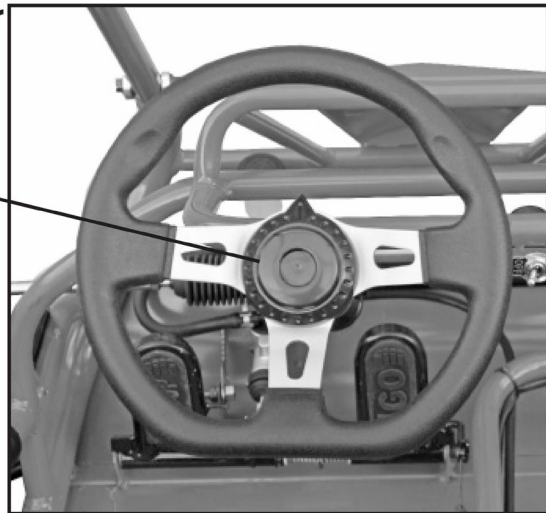

# SEAT INSTALLATION

1. Install seat using the M8 Wing bolt, lockwasher, flat washer.

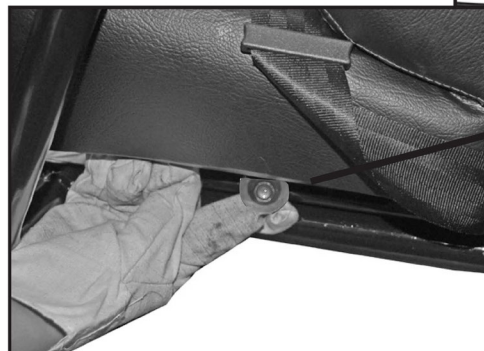

# BRUSH GUARD INSTALLATION

- M8 X 60 bolts 12ea. (1)
- M8 Lock Nuts 6 ea. (2)
- M8 Concave Spacers 18 ea. (3)
- M8 Flat Washers 18 ea. (4)



1. Attach Main Brush Guards with M8 bolts (1), washers (4), Concave supports (3), and Lock Nuts (2).

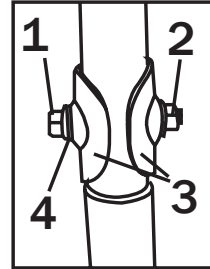

Note: Do not tighten bolts at this time, keep bolts loose until the brush guard is completely assembled.

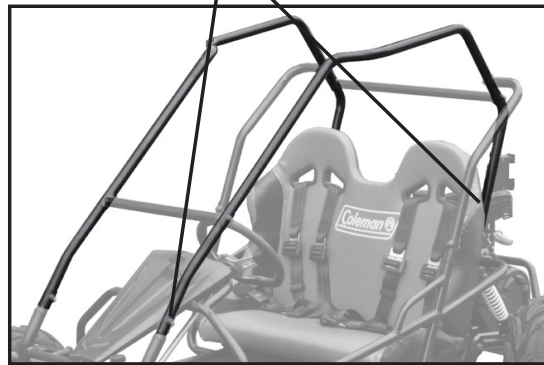

2. Attach Center and Side Supports with M8 bolts (1), washers (4), Concave supports (3), and Lock Nuts (2).

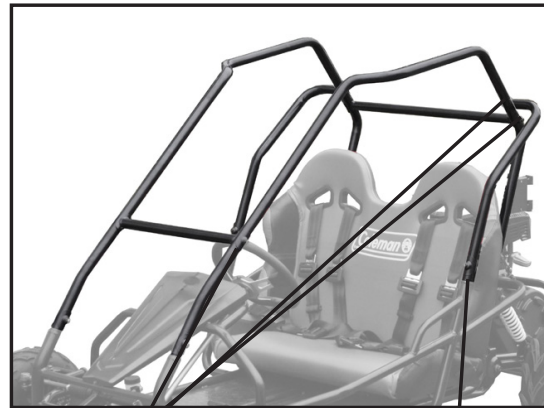

Tighten all bolts on rack and Brush Guard assembly.

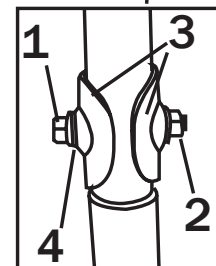
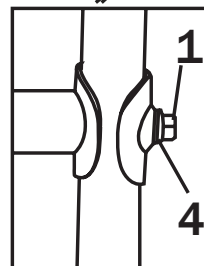

# REAR RACK INSTALLATION

Flange Bolt M8×22 (1)

Lock Nut M8 (2)



Assemble the rear rack to the roll cage mounting point with Flange Bolt M8×22 (1) and Lock Nut M8 (2).

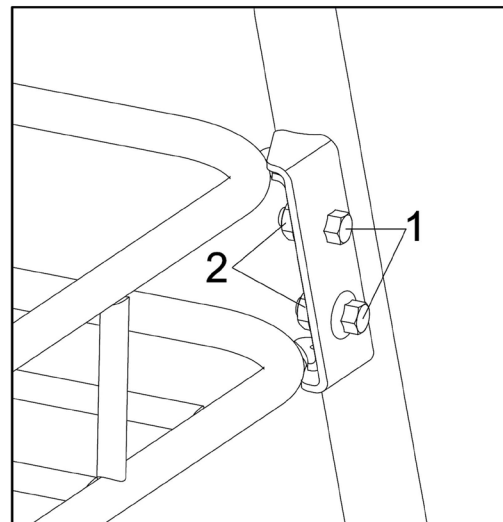
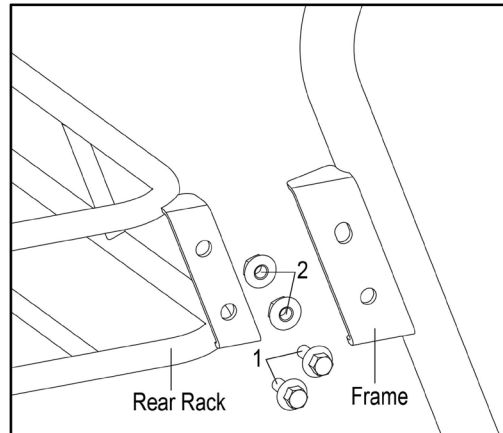

# REAR SAFETY NET

1. Attach safety net to upper cross brace on brushguard assembly (1)

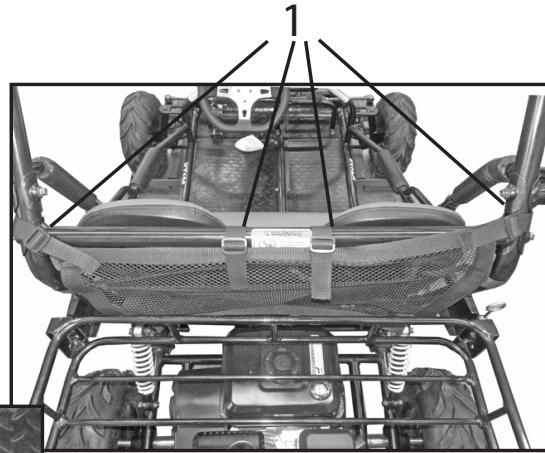

Back View



1

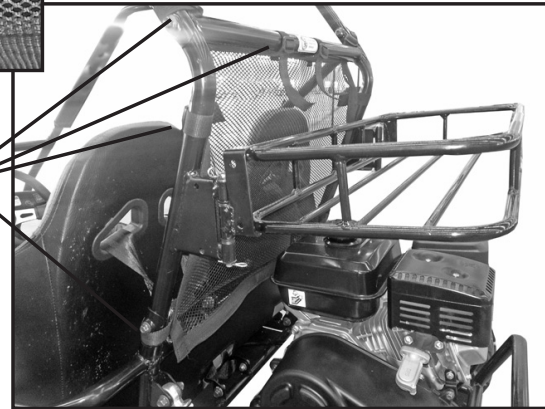

Side View



# REAR SHOCK ASSEMBLY

## Hardware:

**M10 X 40 bolts 2ea. (1)**

**M10 Lock Nuts 2ea. (2)**

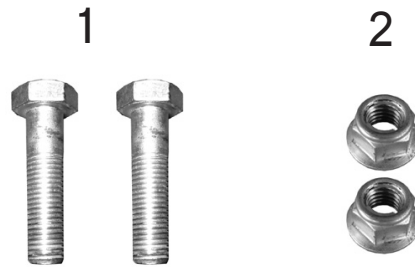

1. Lift center of Go-Kart high enough to install rear shocks.

Note: A floor jack can be used to lift the go-kart.

2. Swing shock in place and **Install shocks on each side of rear assembly. Attach shocks to shock mounts with M10 bolts (1) and Lock Nuts (2).**

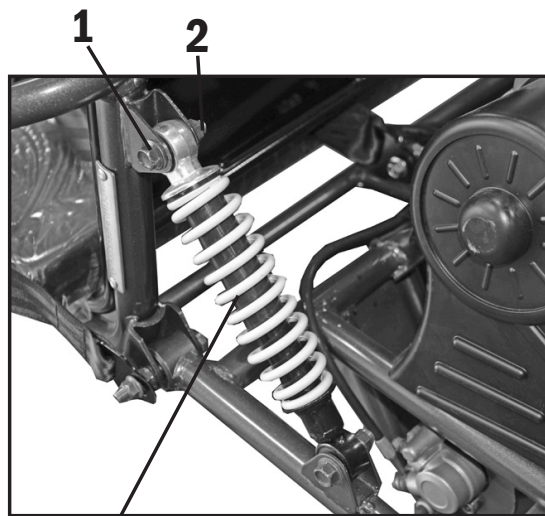

Shock

# PRE-RIDE INSPECTION

Inspecting and checking the condition of the Go Kart before each ride is important. Following the pre-ride check list will help insure the you do not have mechanical problems which could result in injury or becoming stranded. Make sure the Go Kart is in good operating condition before each ride.

**⚠ WARNING**

Failing to inspect and maintain your Go Kart could be hazardous.

Not following the pre-ride inspection procedures could result in losing control of the Go Kart resulting in an accident or damage to the Go Kart

Always perform a Pre-ride inspection before each ride.

**⚠ WARNING**

Performing maintenance and checks while the engine is running could be hazardous.

You could be severely injured by moving parts or hot surfaces.

Never perform maintenance or check procedures while the engine is running with the exception of checking the ignition switch or throttle.

WHAT TO CHECK	CHECK FOR
Steering	<ul style="list-style-type: none"> <li>• Smoothness</li> <li>• No restriction of movement</li> </ul>
Brakes	<ul style="list-style-type: none"> <li>• Correct fluid level</li> <li>• Inspect hoses for leaks</li> <li>• Inspect brake pads for wear.</li> </ul>
Tires	<ul style="list-style-type: none"> <li>• Proper tire pressure</li> <li>• Proper tread depth</li> <li>• Rubber has no cracks</li> </ul>
Fuel Tank	<ul style="list-style-type: none"> <li>• Enough fuel for the ride</li> <li>• Fuel cap secure</li> <li>• Hoses have no signs of cracks or leaks</li> </ul>
Throttle Pedal	<ul style="list-style-type: none"> <li>• Pedal snaps back to idle when released</li> <li>• Operates freely</li> </ul>
Engine Ignition switch	<ul style="list-style-type: none"> <li>• Switch shuts off engine when activated.</li> </ul>
Engine Oil	<ul style="list-style-type: none"> <li>• Correct oil level</li> </ul>
Torque Converter Guard	<ul style="list-style-type: none"> <li>• No damage</li> <li>• Securely attached</li> </ul>
Drive Chain	<ul style="list-style-type: none"> <li>• Proper tension</li> <li>• Lubricated</li> <li>• No excessive wear or damage</li> </ul>
General Condition	<ul style="list-style-type: none"> <li>• All nuts and bolts tight</li> <li>• No rattles from engine or frame while running</li> </ul>



## **WARNING**

NEVER ATTEMPT TO START THIS GO KART WITHOUT READING AND UNDERSTANDING THE OWNER'S/ OPERATOR'S MANUAL. THE OWNER'S/ OPERATOR'S MANUAL PROVIDES INFORMATION PROVIDES INFORMATION ON SAFETY, PARTS, FUNCTIONS, PRE-RIDE INSPECTION, STARTING AND MAINTENANCE



# POWERSPORTS

**(888) 405-8725**

**1775 E. University Dr., Tempe, AZ 85281**

**[www.colemanpowersportsusa.com](http://www.colemanpowersportsusa.com)**

---

**[www.facebook.com/colemanpowersportusa.com](http://www.facebook.com/colemanpowersportusa.com)**

**[www.instagram.com/colemanpowersports\\_usa](http://www.instagram.com/colemanpowersports_usa)**

