

User Manual for KingSmith WalkingPad Treadmill

Please read the User Manual carefully before using the Treadmill, and keep it properly.



Manufacturer: Beijing Kingsmith Technology Co., Ltd.
Address: Floor 4, Building 25, Area 18, ABP Park, Fengtai, Beijing, China.
MADE IN CHINA

Model No.: *TRX21F*

WalkingPad

KING SMITH



Caution: The user is cautioned that changes or modifications not expressly approved by the party responsible for compliance could void the user's authority to operate the equipment.

This device complies with Part 15 of the FCC Rules. Operation is subject to the following two conditions: (1) this device may not cause harmful interference, and (2) this device must accept any interference received, including interference that may cause undesired operation.

NOTE: This equipment has been tested and found to comply with the limits for a Class B digital device, pursuant to Part 15 of the FCC Rules. These limits are designed to provide reasonable protection against harmful interference in a residential installation. This equipment generates, uses and can radiate radio frequency energy and, if not installed and used in accordance with the instructions, may cause harmful interference to radio communications. However, there is no guarantee that interference will not occur in a particular installation.

If this equipment does cause harmful interference to radio or television reception, which can be determined by turning the equipment off and on, the user is encouraged to try to correct the interference by one or more of the following measures:

- Reorient or relocate the receiving antenna.
- Increase the separation between the equipment and receiver.
- Connect the equipment into an outlet on a circuit different from that to which the receiver is connected.
- Consult the dealer or an experienced radio/TV technician for help.

FCC Radiation Exposure Statement

This equipment complies with FCC radiation exposure limits set forth for an uncontrolled environment.

This transmitter must not be co-located or operating in conjunction with any other antenna or transmitter.

Connect this appliance to a properly grounded outlet only. See Grounding Instructions.

This appliance is not intended for use by persons with reduced physical, sensory or mental capabilities, or lack of experience and knowledge, unless they have been given supervision or instruction concerning use of the appliance by a person responsible for their safety. Keep children under the age of 13 away from this machine.

To reduce the risk of electric shock, this appliance has a polarized plug (one blade is wider than the other). This plug will fit in a polarized outlet only one way. If the plug does not fit fully in the outlet, reverse the plug. If it still does not fit, contact a qualified electrician to install the proper outlet. Do not change the plug in any way.

The appliance is intended for household.



DANGER – To reduce the risk of electric shock:

Always unplug this appliance from the electrical outlet immediately after using and before cleaning.



WARNING – To reduce the risk of burns, fire, electric shock, or injury to persons:

- 1) An appliance should never be left unattended when plugged in. Unplug from outlet when not in use, and before putting on or taking off parts.
- 2) Close supervision is necessary when this appliance is used by, on, or near children, invalids, or disabled persons.
- 3) Use this appliance only for its intended use as described in this manual. Do not use attachments not recommended by the manufacturer.
- 4) Never operate this appliance if it has a damaged cord or plug, if it is not working properly, if it has been dropped or damaged, or dropped into water. Return the appliance to a service center for examination and repair.
- 5) Do not carry this appliance by supply cord or use cord as a handle.
- 6) Keep the cord away from heated surfaces.
- 7) Never drop or insert any object into any opening.
- 8) Do not use outdoors.
- 9) Do not operate where aerosol (spray) products are being used or where oxygen is being administered.
- 10) To disconnect, turn all controls to the off position, then remove plug from outlet.

Contents

1. Product and Accessories	04
2. Functional Diagram	05
3. Guide for Initial Use	09
4. Operational Instructions	11
5. Trademark and Legal Statement	14
6. Safety Precautions	15
7. Care and Maintenance	18
8. Replacement and Disposal	19

Welcome!

Thanks for choosing KingSmith WalkingPad Treadmill (hereinafter referred to as "the Treadmill"), which boasts a simple, exquisite, and innovative design. Users of the Treadmill can enjoy an at-home workout and boost the quality of life. The Treadmill is for home use only, not for business, leasing, or public organization purposes.

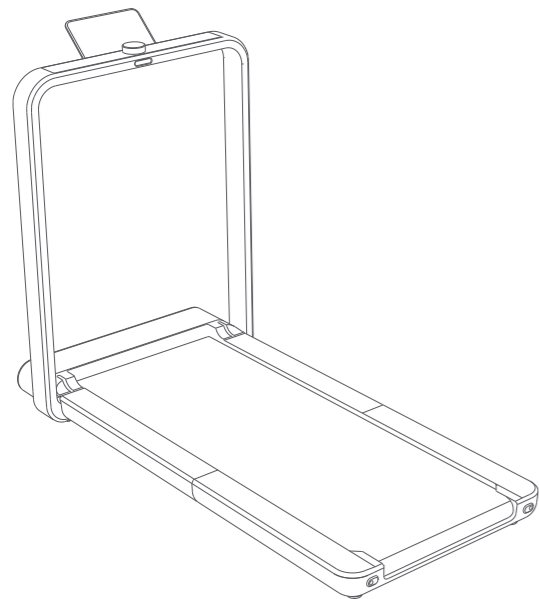

Performance index	Detailed parameters
Applicable age	14-60 years old
Speed range	1-12 km/h (1-7.5 mi/h)
Running area	460×1210 mm (18.1×47.6 inch)
Maximum load	110 kg (240 lbs)
Frequency	50/60 Hz
Voltage	100-127 V~
Power	918 W
Net weight	37 kg (81 lbs)
Unfolding dimension	1419×711×1053 mm (55.8×27.9×41.4 inch)
Folding dimension	1007×711×225 mm (39.6×27.9×8.8 inch)

1. Product and Accessories

Please carefully check whether the items contained in the packing box are complete and intact, and contact the retailer once finding any items missing or damaged.

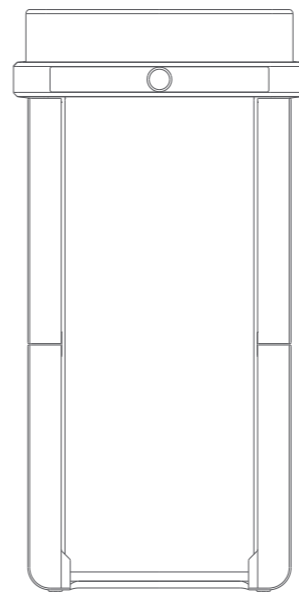

Treadmill

Accessories



Power cord



Mobile phone holder



Safety key



Wrench



Manual

2. Functional Diagram

1. Unfolding state

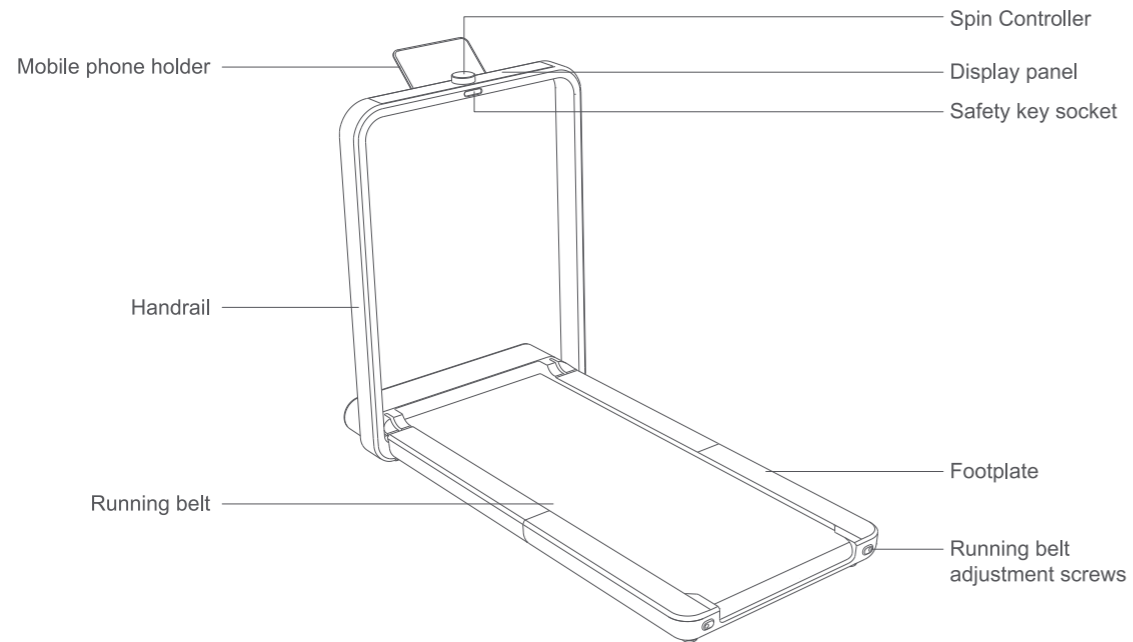

2. Folding state

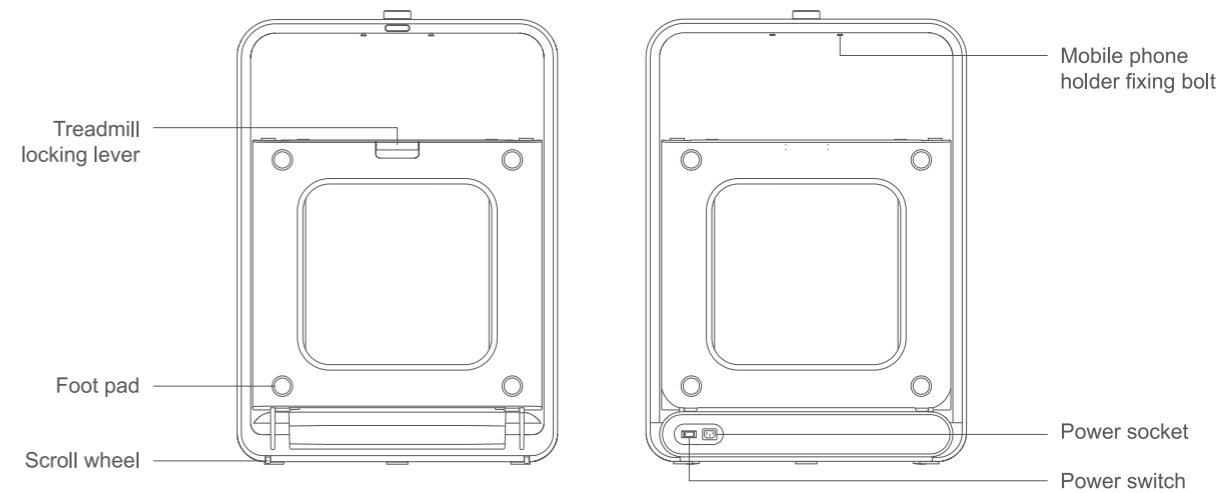

3. Functions of the display panel

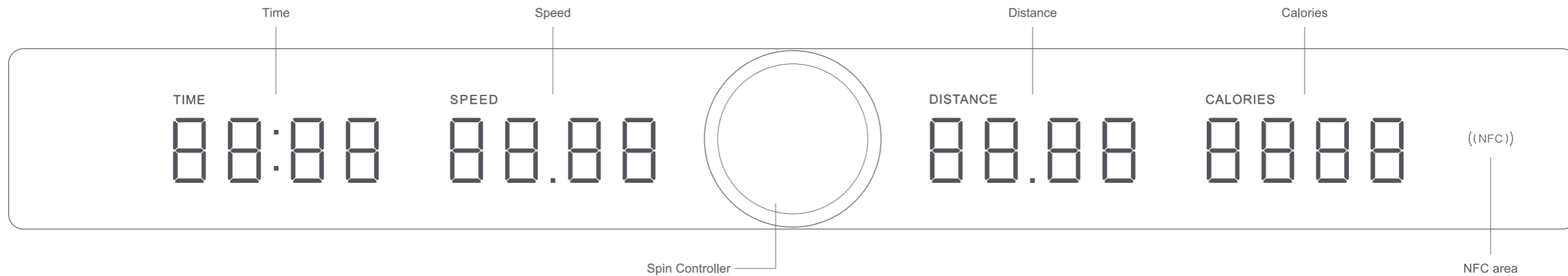

3. Guide for Initial Use

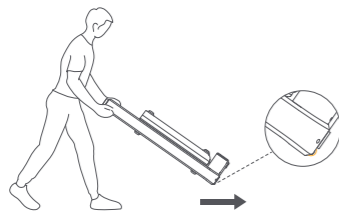

1. Before pushing or pulling the Treadmill, please make sure the Treadmill is locked and placed on flat ground.

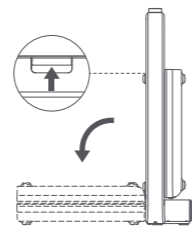

2. Pull up the treadmill locking lever to unlock the Treadmill and slowly keep it flat.

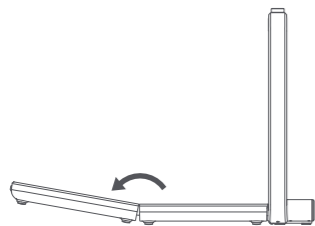

3. Unfold the Treadmill, adjust the running belt to the center position, slowly unfold and press the treadmill, or rotate the bottom foot pad to make it completely flat.

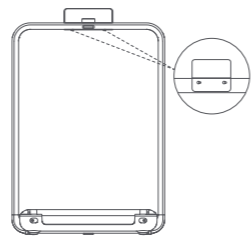

4. Take out the mobile phone holder from the accessory box, connect two large holes to the fixing bolts beneath the handrail, then push towards the direction of the narrow ends of the holes, thus fixing the mobile phone holder to the handrail.

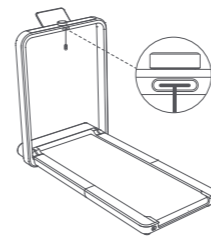

5. Take the safety key out of the accessory box, and insert it into the safety key socket in the middle of the handrail.

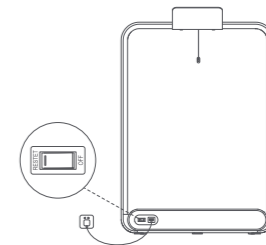

6. Turn on the Treadmill switch after connecting the power cord.



7. Scan the QR code above or search for "KS Fit" in App Store or Google Play to complete the installation and sign-up.

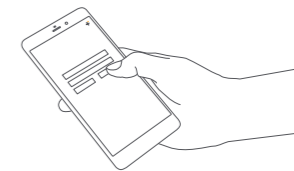

8. Before using the Treadmill, open the APP, add and bind the Treadmill following the prompts.

4. Operational Instructions

1. Start running



1. After the Treadmill is powered on, the display panel will be lit up, and all parameters will be displayed as "0" by default.

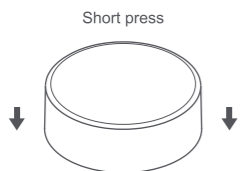

3. After the Spin Controller is short pressed for 3 seconds in the default mode, the Treadmill will be started slowly.

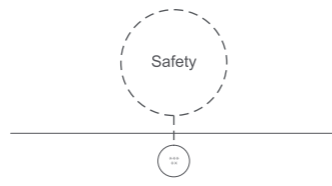

2. If the safety key is not inserted, a prompt of "Safety" will be displayed, and the "SAFE" mode will be activated. If failing to start the Treadmill, please insert the safety key.

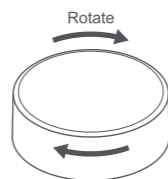

4. Rotate the Spin Controller clockwise to accelerate. Rotate the Spin Controller counterclockwise to decelerate.

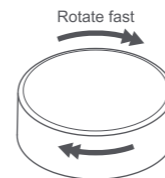

5. Fast regulation of speed: Rotate the Spin Controller quickly to switch the speed levels, which will be switched among 1, 3, 6, 9, 12 km/h (1, 2, 4, 6, 7.5 mi/h).

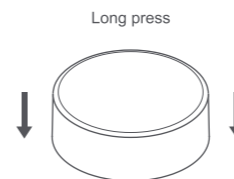

7. In the pause mode, after the Spin Controller is long pressed for 2 seconds or there is no operation for 180 seconds, the Treadmill will stop, and all parameters will return to "0" by default.

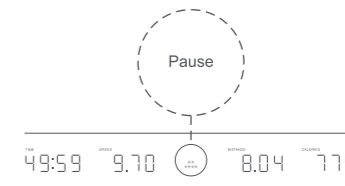

6. After the Spin Controller is short pressed during movement, or after the no-load operation lasts for 5 minutes, the Treadmill will slowly stop and enter the pause state. Then, short press the Spin Controller again to restart the Treadmill, which will return to the original speed level before the pause.



8. After finishing the exercise, please turn off the power switch and put away the power cord.

2. Other statuses displayed on the Spin Controller screen



Instructions for special status are also displayed via the Spin Controller screen. As the Treadmill system will be upgraded and optimized regularly, some operations might be adjusted, and please refer to the actual Treadmill possessed when operate.

3. Standby and Wakeup

In the standby mode (all parameters are displayed as "0"), if the Spin Controller is long pressed for 3 seconds or the Treadmill is kept idle for 5 minutes, the Treadmill will be switched to standby status, and the panel lights will be off. In the standby mode, short press the Spin Controller to wake up the Treadmill.

4. Fault codes 

- E01: Software overcurrent
- E02: Hardware overcurrent
- E03: IPM module overheating
- E04: Undervoltage protection
- E05: Overvoltage protection
- E06: Motor open-phase protection
- E07: Motor lock-rotor protection
- E08: Sensor fault
- E09: Motor failure to start
- E12: Motor overcurrent protection
- E13: Overload protection
- E14: Hall signal loss
- E15: Communication error

Various patents relating to the KingSmith WalkingPad Treadmill series are developed and copyrighted by Beijing KingSmith Technology Co., Ltd. ("KingSmith" for short). Without the written permission of KingSmith, any organization or individual shall not copy or distribute all or any part of this User Manual and shall not use the patents contained thereof. This User Manual, as far as possible, has included various latest function introductions and operational instructions at the time of being printed. Nevertheless, there might be discrepancies between the purchased Treadmill and those described herein due to a continuous optimization in functions and designs. Therefore, the actual Treadmill shall prevail in case of any deviations in color and appearance.

6. Safety Precautions

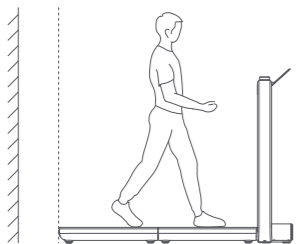

⚠ Please hold the handrail with both hands to support the body before jumping off the treadmill in an emergency. Therefore, there should be a distance of at least 2000 mm or above behind the Treadmill.

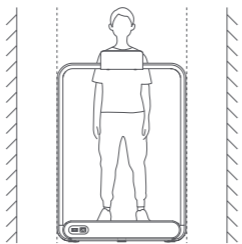

⚠ The distance between the Treadmill and other objects on the two sides should be at least 500 mm.

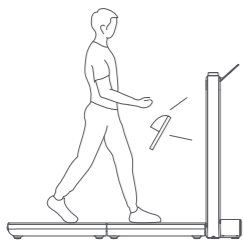

⚠ Please put on sports shoes and clothes when using the Treadmill, and conduct proper exercise according to one's health condition. If feeling uncomfortable in the exercise process, please stop immediately and consult a doctor to avoid the possible risk of injury.

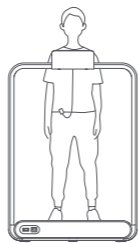

⚠ Before using the Treadmill, please nip the other end of the safety key to clothes. In case of any emergency, pull off the safety key to stop the Treadmill immediately.

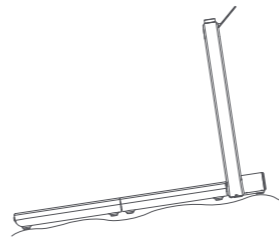

⊗ Strictly prohibit using the Treadmill on any uneven ground.

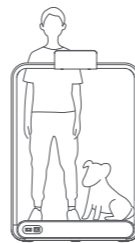

⊗ Do not use the Treadmill in the company of any pets.



⚠ Unplug the power cord when the Treadmill is not used.



⊗ Do not step on the head of the Treadmill.

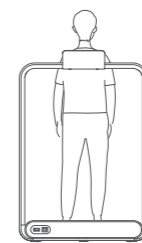

⊗ Do not use the Treadmill backward or sideways.



⚠ The elderly, children and pregnant women should use this product prudently.

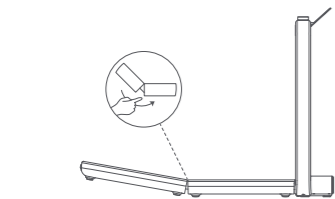

⚠ Keep hands safe.

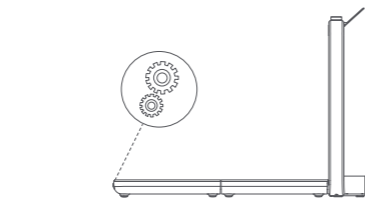

⚠ Keep belongings well in case of getting stuck.

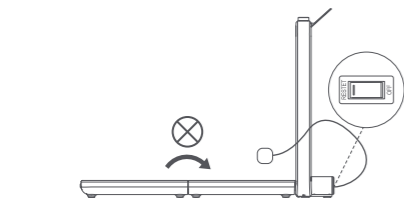

⊗ Do not fold the Treadmill when the power is not turned off.

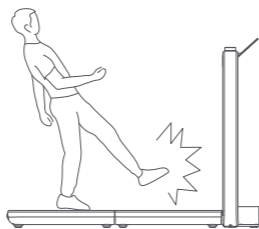

⊗ Do not get on or off the Treadmill when the running belt is still working.

7. Care and Maintenance

1. Treadmill cleaning



- Turn off the Treadmill and unplug the power cord.
- Apply an appropriate amount of soft detergent to a piece of cloth entirely made of cotton. Do not spray the detergent directly on the running belt or use any acid or corrosive detergent to avoid damage.
- Do not wipe beneath the running belt.
- As a regular practice, clean the dust and stains that might appear on the ground behind the Treadmill tail

2. Running belt slippage and correction

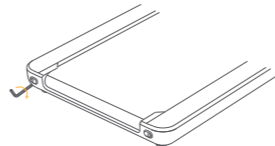

- Running belt inclination towards left: rotate the left adjustment screw for a 1/4 circle clockwise.
- Running belt inclination towards right: rotate the right adjustment screw for a 1/4 circle clockwise.
- Running belt slippage: rotate the left and right adjusting screws for a 1/2 circle clockwise, respectively.
- After regulating each time, let the Treadmill run at a speed of 4 km/h (3 mi/h) for 1-2 minutes to observe the correction. If necessary, please adjust again.

3. Running belt lubrication

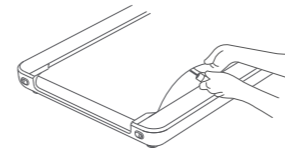

- Turn off the Treadmill and unplug the power cord.
 - Uplift the edge of the running belt, and apply silicone oil to its inner surface. It is easier to operate when the treadmill is not fully unfolded.
 - Start the Treadmill and let it run at 4 km/h (3 mi/h) for 10-20 seconds before use.
 - Apply 5-10ml of silicone oil for lubrication each time to avoid any negative impacts caused by the excessive use of silicone oil.
 - Lubricate the running belt every three months.
- Silicone oil is not included, please purchase separately.

8. Replacement and Disposal



The battery contained in this appliance must be removed for disposal.

When replacing the battery, use only original battery, available from our online parts shop.

The battery compartment is located on the back of the appliance. Open the compartment by removing the screw in the cover using a suitable screwdriver, and then press the lower end of the locking catch on the connectors. In that way, both sides of the connection can be separated by pulling them apart.

When inserting a new battery, push together the two connectors and ensure that the catch locks over the stop.

Never dispose of old battery in domestic garbage, but only through the proper public collection points. This also applies to the battery of defective appliances.



Devices marked with this symbol must be disposed of separately from your household waste, as they contain valuable materials that can be recycled. Proper disposal protects the environment and human health. Your local authority or retailer can provide information on the matter.