



'S' SERIES SELF-PRIMING CENTRIFUGAL PUMP

BULLETIN
PP-638C
JAN 2021

**A high performance transfer pump powered by
Honda's GX Series OHV engine.**



POWERED BY
HONDA
ENGINES
GX Series
COMMERCIAL



Pump:

- Constructed of corrosion resistant polyester.
- Stainless Steel fasteners throughout.
- EPDM elastomer (Buna and Viton® available).
- Stainless steel shaft seal with carbon and ceramic faces.
- Your choice of 2" or 3" ports.
- Maximum shut off pressure 52 psi.
- Suction Lift to 25 ft (7.6 meters)
- Flows to 280 GPM

Engine:

- Honda Series GX160 and GX200 (3").
- Overhead valve design.
- Fast, easy, reliable starting.
- Meets Carb and EPA emission standards.
- Cast iron cylinder sleeve.
- Electronic ignition.
- Oil alert low oil shut off.
- 3 year commercial use warranty.

PERFORMANCE CURVES

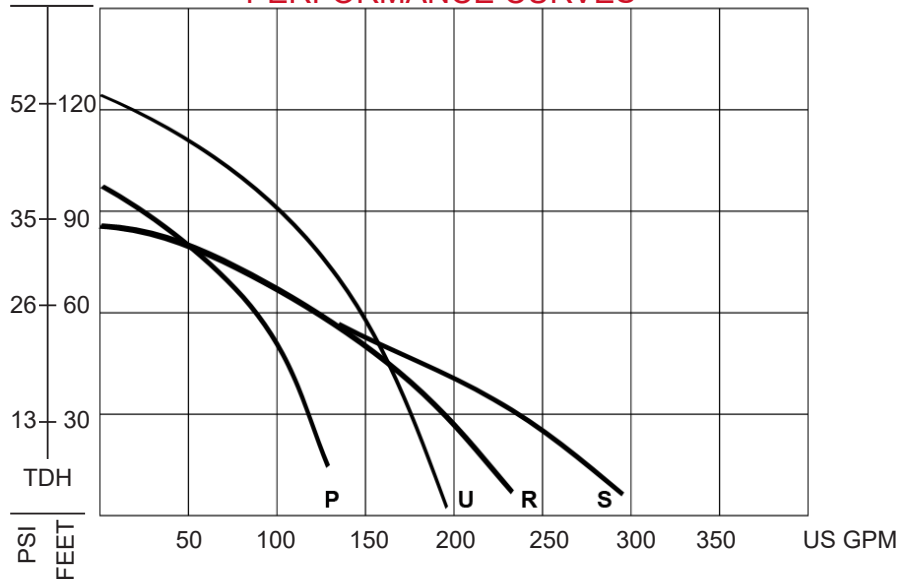

CURVE	MODEL	PORT SIZE	MAX FLOW	MAX TDH	WEIGHT
P	SE2PL E5HCP	2" NPT	145 GPM	100 ft	50 lbs
U	SE2UL E5HCP	2" NPT	200 GPM	126 ft	50 lbs
R	SE2RL E5HCP	2" NPT	230 GPM	83 ft	50 lbs
S	SE3SL E6HCP	3" NPT	280 GPM	83 ft	55 lbs



41 Industrial Circle Phone: 717-925-8240
 Lancaster PA 17601 Toll Free: 800-233-3861
 email: sales@pacerpumps.com FAX: 717-925-8242
 www.pacerpumps.com





CARING FOR PACER PUMPS

When handling agriculture fertilizer and chemicals, flush pump with fresh, clean water and drain completely.

EPDM rubber components are not compatible with petroleum products. Do not use petroleum products when preparing pump for storage.

- Housing, volute and impeller: glass-reinforced polyester.
- Rubber parts: EPDM (Buna and Viton® available).
- Shaft seal: Stainless steel with carbon and ceramic faces, EPDM fitted.
- Hardware: internal and external stainless steel fasteners.
- Working pressure: to 52 PSI.
- Flow: to 280 GPM.

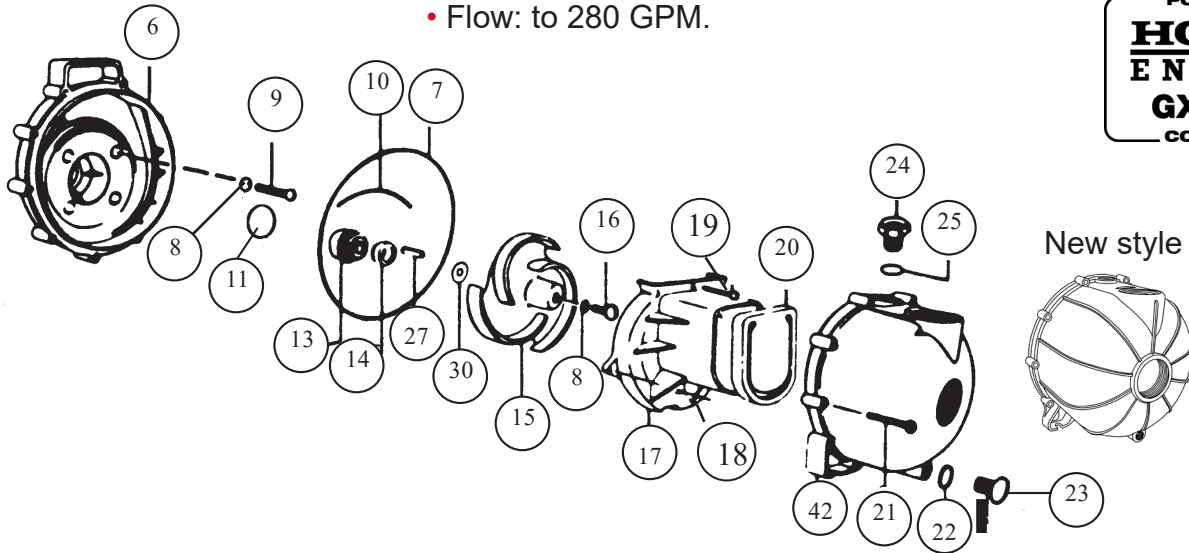

Parts list for model numbers starting with SE2PL, SE2UL, SE2RL and SE3SL.

REF. NO.	DESCRIPTION	QTY/PUMP	SE2PL	SE2UL	SE2RL	SE3SL
6	Bracket	1	P-58-0703 30B	P-58-0703 30B	P-58-0703 30B	P-58-0703 30B
7	'O'-ring, body	1	P-58-0719 72	P-58-0719 72	P-58-0719 72	P-58-0719 72
8	'O'-ring, screw	5	P-58-0717 72	P-58-0717 72	P-58-0717 72	P-58-0717 72
9	Screw, bracket	4	P-58-0715 10	P-58-0715 10	P-58-0715 10	P-58-0715 10
10	'O'-ring, segment	1	P-58-0754 72	P-58-0754 72	P-58-0754 72	P-58-0754 72
11, 13 & 14	Shaft seal & 'O'-ring	1	P-58-0714 12	P-58-0714 12	P-58-0714 12	P-58-0714 12
15	Impeller	1	P-58-0704 30	P-58-0706 30	P-58-0975 30	P-58-0975 30
16	Screw, impeller	1	P-58-0716 10	P-58-0716 10	P-58-0716 10	P-58-0716 10
17	Volute	1	P-58-0702 30	P-58-0702 30	P-58-0977 30	P-58-0977 30
18	Screw, side volute	2	P-58-0725 10	P-58-0725 10	P-58-0725 10	P-58-0725 10
19	Screw, top volute	1	P-58-0997 10	P-58-0771 10	P-58-0771 10	P-58-0771 10
20	Check valve	1	P-58-0705 72	P-58-0705 72	P-58-0705 72	P-58-0705 72
21	Screw, body	10	P-58-1206 10	P-58-1206 10	P-58-1206 10	P-58-1206 10
22	'O'-ring, drain plug	1	P-58-1009 72	P-58-1009 72	P-58-1009 72	P-58-1009 72
23	Plug, drain	1	P-58-0723 30	P-58-0723 30	P-58-0723 30	P-58-0723 30
24	Plug, filler	1	P-58-0722 30B	P-58-0722 30B	P-58-0722 30B	P-58-0722 30B
25	'O'-ring, filler plug	1	P-58-0765 72	P-58-0765 72	P-58-0765 72	P-58-0765 72
27	Key	1	P-58-0718 30	P-58-0718 30	P-58-0718	P-58-0718
30	Shim	As required	P-58-0778 11 (.006")	P-58-0778 11 (.006")	P-58-0778 11 (.006")	P-58-0778 11 (.006")
		"	P-58-0778 12 (.015")	P-58-0778 12 (.015")	P-58-0778 12 (.015")	P-58-0778 12 (.015")
		"	P-58-0778 13 (.030")	P-58-0778 13 (.030")	P-58-0778 13 (.030")	P-58-0778 13 (.030")
42	Body	1	P-58-1002 30B	P-58-1002 30B	P-58-1002 30B	P-58-0755 30B

NOTE: This parts list is intended for EPDM fitted pumps only.