

COMPRESSED AIR DRYERS



INSTRUCTION MANUAL

Airbase Industries Energy Efficient
Refrigerated Air Dryers



WARRANTY NOTICE

Failure to follow the instructions and procedures in this manual or misuse of this equipment will VOID its warranty !



TABLE OF CONTENTS

1.	IMPORTANT SAFETY NOTES - Please read	4
1.1.	Transportation	4
1.2.	Positioning	4
1.3.	Installation	4
1.4.	Before operating	4
1.5.	Qualified service personnel	5
1.6.	Maintenance by the user	5
2.	INTRODUCTION TO THE PDRCF / EDRCF DRYER	5
3.	OPERATION	9
4.	ELECTRICAL CONTROLLER	11
4.1.	Digi-Pro	11
4.2.	ESD 3.....	13
5.	TECHNICAL SPECIFICATIONS.....	19
6.	DIAGRAMS.....	20
6.1.	Air Flow Diagrams.....	20
6.2.	Electrical Diagrams.....	24
7.	ID DIAGRAMS.....	34
	GENERAL ARRANGEMENTS.....	47
8.	EXPLODED DIAGRAMS	48
9.	COMPONENTS LOCATION	74
10.	TROUBLESHOOTING	75
11.	WARRANTY	77

I. IMPORTANT SAFETY NOTES



When operating the air dryer the operator must apply safe working methods and observe all local safety instructions and relevant regulations.

- A) Prior to installation, the dryer and the compressed air system are to be depressurized and disconnected from the electrical main supply.
- B) The user is responsible for safe operating conditions. Parts and accessories must be replaced if inspection shows that safe operation cannot be assured.
- C) Installation, operation, maintenance and repair are only to be authorized, trained and skilled technicians.
- D) The minimum and maximum values stated must be followed, as well as all of the safety precautions described in this manual.
- E) If any statement in this manual does not comply with the local code and laws, the strongest standard is to be applied.

1.1. Transportation

- A) Use care and caution when transporting the dryer. Avoid dropping and other physical abuse.
- B) A forklift can be used to transport the dryers provided the forks are long enough to support its full width or length and caution is used throughout the move.

1.2. Positioning

- A) The dryer must be installed horizontally. A minimum of 20 in. clearance around the dryer is necessary to allow a good ventilation and easy access for servicing.
- B) The ambient temperature in the room should not exceed 113°F and should not be below 39.2°F, also taking the heat radiated by the dryer into account.
- C) (40 watt for each liter/sec under ISO 7183-A condition or 18 watts for each SCFM under ISO 7183-B condition).
- D) There should be no chemicals in the atmosphere that will damage the copper source. (Ammonia gas etc.)

1.3. Installation

In addition to the general mechanical construction procedures and local code regulations, the following instructions need to be understood and followed:

- 1) Only authorized, trained and skilled technicians should install the compressed air dryer.
- 2) Safety devices, protecting covers or insulation in the dryers never to be dismantled or modified. Each pressure vessel or accessory installed outside the dryer with air above atmospheric pressure must be fitted with the required pressure relief safety valves.

1.4. Before Operating

The following must be observed before operating the air dryer:

- A) Review all safety precautions.
- B) The dryer connection piping measurements must be selected correctly. (See Technical specifications)
- C) The dryer connection piping must be adapted to the operating pressure. (See Technical specifications)
- D) Never operate the dryer at pressure above the maximum specified on the dryer label (check the technical specs too).
- E) The drains should be opened to atmosphere. If the drains are connected to a pipe / hose, the diameter of the hose / pipe should be large enough to create no back pressure during draining. It is not recommended to reduce the diameter of the hose / pipe less than port that is given at the drain outlet of the unit. The hose / pipe should be at atmospheric pressure at all time. Back pressure in relevant pipe will result in permanent damage on drain system and the affect function of the filters and / or dryers.

1.5. Qualified service technicians

- A) Maintenance and repairs should only be performed when the air dryer is shut down and depressurized and when the main power switch is turned off. Lock and tag out power supply is recommended.
- B) Use only the appropriate tools for maintenance and repair.
- C) Before dismantling a part under pressure, disconnect the pressure sources and depressurize the system.
- D) Proceed carefully during maintenance and repair. Prevent dirt from entering by covering parts and orifices with a clean cloth, paper or tape. A receiver should never be welded or modified in any way.
- E) Never leave tools, loose parts or cleaning rags in or on the air dryer.
- F) Before putting the dryer into service, check the settings of the control and safety devices as well as the pressure and the temperature of the compressed air circuit.

1.6. Maintenance by the user

- A) Keep the dryer clean.
- B) Regularly check the correct operation of the condensate drain water trap.
- C) Every six months, check and clean the drain strainer by undoing the access screw and rinsing the filter with tap water to remove the trapped dirt from the inside.
- D) For aircooled dryers, clean the air condenser as soon as it's dirty or clogged.
- E) For optional water-cooled condensers, use only clean water and install a water filter if needed. Use proper water treatment if calcium levels are high.
- F) Check the trouble-shooting list in case of maintenance problems.
- G) Check operating pressures, temperatures and time settings after maintenance. If operating and safety devices function properly, the air dryer may be used.

2. INTRODUCTION TO THE DRYER

B) Purpose of this dryer

- 1) This refrigerated compressed air dryer has been designed to remove water vapor from the industrial compressed air system.
- 2) This dryer has been designed for indoor operation.
- 3) The minimum and maximum values stated must be observed, as well as the safety precautions described in this manual.

C) Dryer label

The following label is affixed on the cabinet of the refrigerant compressed air dryer.

REFRIGERATED AIR DRYER			 <small>Dayton, OH, USA</small>		
MODEL #	<input type="text"/>	CFM	<input type="text"/>	SERIAL #	<input type="text"/>
Max Refrigerant Pressure	<input type="text"/>		Voltage	<input type="text"/>	<input type="text"/>
Max Air Pressure	<input type="text"/>		IP Rating	<input type="text"/>	
Max Air Inlet Temp	<input type="text"/>		Refrigerant	134 a	<input type="text"/>
Min Ambient Temp	<input type="text"/>		Weight	<input type="text"/>	<input type="text"/>
Max Ambient Temp	<input type="text"/>		Fan	<input type="text"/>	<input type="text"/>
Min Circuit Ampacity	<input type="text"/>		Compressor	<input type="text"/>	<input type="text"/>
Max Protective Device Rating	<input type="text"/>		Largest Motor	<input type="text"/>	<input type="text"/>
<small>FOR SALES, SERVICE, PARTS OR TECHNICAL SUPPORT CALL US TOLL FREE AT 877.283.7614</small>					

Dryer label descriptions

Model #:	Dryer Model No
CFM:	Cubic feet per minute
Serial #:	Dryer Serial No
Max Refrigerant Pressure:	Dryer maximum working pressure
Max. Air Pressure:	Maximum air pressure
Max. Air Inlet Temp.:	Maximum air inlet temperature
Min. Ambient Temp. :	Minimum ambient temperature
Max. Ambient Temp. :	Maximum ambient temperature
Min. Circuit Ampacity :	Minimum circuit ampacity
Max Protective Device Rating :	Maximum Protective device rating
Voltage:	Main supply voltage
IP Rating:	Protection rating
Refrigerant 134a :	Amount of refrigerant gas used
Weight :	Dryer weight
Fan :	Model of fan used
Compressor :	Model of compressor used
Largest Motor:	Model of motor used

D) Working details

1) Refrigerant circuit:

The refrigerant circuit can be divided in **3** parts:

- A) Low pressure section with an evaporator (heat exchanger)
- B) High-pressure section including: Condenser, liquid receiver, (if installed) and the filter dryer.
- C) Control circuit including: Compressor, Expansion valve, by-pass valve (if installed), Fan pressure switch (if installed)

2) For water - cooled dryers:

- A) Water valve
- B) Safety high pressure switch (if installed)

3) The Refrigerant circuit operates as follows:

- A) The compressor compresses gaseous refrigerant to a high temperature.
- B) The hot refrigerant condenses in the condenser. Being liquefied it is stored in the liquid receiver (if installed).
- C) The liquid is taken out the storage vessel and injected in the evaporator (heat exchanger) by an expansion valve. This expansion valve is protected by a filter, which removes particles and humidity that could be in the circuit.
- D) The injected liquid fills in the refrigerant section of the air / refrigerant heat exchanger and evaporates by taking out the humidity from the compressed air. The gaseous refrigerant is sucked in the compressor and the cycle carries on.
- E) In order to keep the evaporation pressure steady, and thus the refrigerant temperature in the heat exchanger, a by-pass valve is injecting hot gaseous refrigerant in the circuit. On certain dryers, an automatic expansion valve regulates the amount of refrigerant.

4) Compressed air circuit:

- A) The saturated hot compressed air flows into the Economiser where it is pre-cooled by the out flowing dry chilled air. In the cold operating conditions the air refrigerant section continues to cool down to dew point and enters the separator where condensates are collected. The outgoing chilled air is then warmed up in the economizer by the hot incoming air. This eliminates condensation on dryer outlet Air Piping.

- B)** The condensates are collected after centrifugal separation and drained out through the automatic trap.
- C)** As long as the compressed air temperature does not drop below dew point, there will be no condensation in the air circuit.

Compressed Air Dryer Working Principle

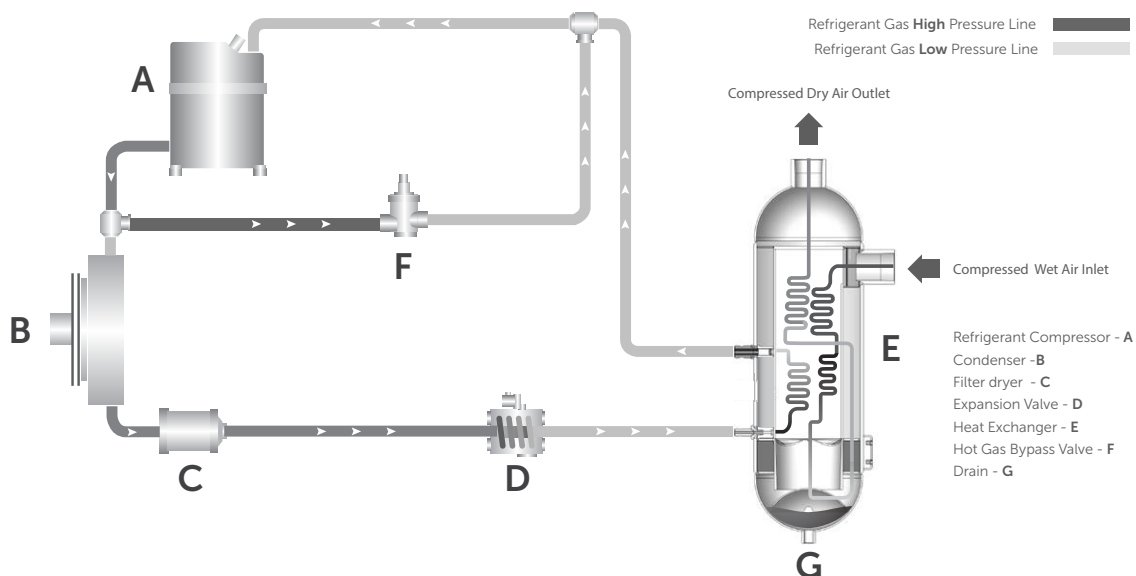

5) Refrigerant compressor

Increases the pressure and temperature of refrigerant. There are two type of compressors commonly used according to refrigerant capacity on this application:

- Piston type
- Scroll type

6) Condenser

Dissipates the heat provided by evaporator and compressor.

There are two type of condensers used on the application:

- Air Cooled Type (standard)

These condensers are designed to dissipate the heat to the ambient air.

The fans are used to force the air flow through the cooling fins to enhance the heat transfer.

- Water Cooled Type (optional)

These condensers are designed to dissipate the heat to a water flow.

A shell and tube heat exchanger is used for this purpose.

7) Refrigerant circuit protection

A) Overload: The single phase refrigerant compressors are equipped with a overload switch

In case of malfunction, of overload switches automatically.

B) High Pressure Safety overload Switch: Refrigerant line is considered as a pressure vessel. That is why it protected against bursts by the help of manually reset switch. It is set to 362 psi for dryers working with R134a

C) Filter dryer: A refrigerant circuit is a closed circuit and total water removal in the refrigerant circuit is paramount in order to obtain a correct operation.

D) To avoid problems, the refrigerant circuit must be vacuumed before loading the refrigerant.

It is equipped with a filter dryer, which also traps any solid particles, which may have migrated into the circuit during assembly.

E) Water-cooled dryers have a safety high-pressure switch.

In case of cooling water failure, the safety switch stops the dryer. When the safety switch has tripped out, it has to be manually resettled before switching on the dryer.

8) Refrigerant circuit controls

A) Liquid refrigerant injection: The liquid refrigerant is into the evaporator by a control valve. This valve is a thermostatic or valve for maintaining a constant overheats of the refrigerant in the evaporator(s).

B) Constant evaporating pressure: In the dryers equipped with a by-pass valve, the evaporating pressure is kept constant by a controlled injection of hot gas from the high-pressure side into the low-pressure section of the circuit.

9) Condensate drain - trap assembly

Dismantling the drain is easy because it can be isolated from the air circuit under pressure with a ball valve. The drain has to be depressurized before being dismantled.

10) Heat Exchanger Modular design

A)The dryers are equipped with a compact Mono Bloc Heat Exchanger module.

This assembly has been specially designed to dry compressed air and is made of:

- 1) An Economiser which pre-cools the entering hot air with the out flowing cold air.
- 2) Air/refrigerant exchanger is cooling down the compressed air.
- 3) A centrifugal separator concentrating all condensates and requiring no maintenance.

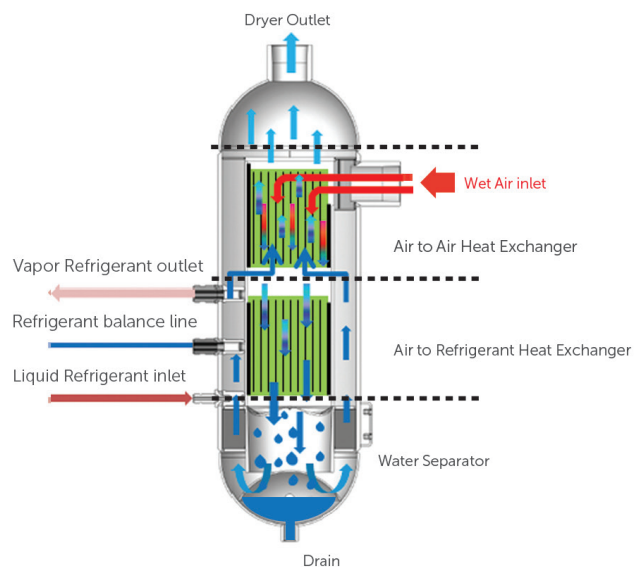

11) Accessories

Temperature switch: Temperature switch: Located inside the dryer, this temperature switch is adjustable from 32°F up to 95 °F.

Digital Controller –DigiPro: This device helps dryer save energy when there is not any compressed air flow in the dryer. This information can be reached; Dewpoint value, periodic maintenance interval display, status report, run time meter, temperature unit selection (°F or °C)

Digital Controller – ESD3: Energy Saving Device: (ESD) This device helps dryer save energy when there is not any compressed air flow in the dryer. This information can be reached; Dewpoint value, periodic maintenance interval display, status report, run time meter, temperature unit selection (°F or °C)
(Please see the models have standard and optional in next page)

3. OPERATION

Control panels for PDRCF / EDRCF Series

The control panel of the dryer includes the following elements:



Single Phase	Digital Controller
PDRCF1150029 / EDRCF1150030 - PDRCF4600288 / EDRCF4600288	Digi-Pro



Three Phase	Digital Controller	Accessories
PDRCF2300575 / EDRCF2300575 - PDRCF4602000 / EDRCF4602000	ESD3	Emergency Stop



IMPORTANT NOTE

The Dryer has two Compressed Air Filters inside.

It is better to change filter element for the best efficiency when the alarm status is active.

It is recommended to keep replacement filter elements in your stock in order to replace them when needed.



ATTENTION

PDRCF / EDRCF range dryers have low pressure drop according its competitors.

Do not use PDRCF / EDRCF range dryers together with other dryers which have higher pressure drop without getting the confirmation from our technical team.

3.1. During Operation

Regularly check the digital temperature controller ESD3 or Digi-Pro on dryer.

3.2 Start up and shut-down

Warning: Avoid leaving the dryer off when compressed air is still flowing through it.

3.3 Starting for the first time or after a long stop

1) Set the rotary switch to "I" This preheats the dryer and turns the drain system on.
It is recommended to leave the dryer power on permanently so the crankcase heater runs continuously.



IMPORTANT NOTE!

2) After a long stop of the dryer it is MANDATORY to allow a preheating period of minimum 4 hours before starting again, to avoid any compressed air flow during preheating.

3) Follow the daily starting and shut down procedure.

3.4 Daily starting and shut-down

1) Push on the ON button to start the dryer.

2) The start light or Dryer Active will indicate that the dryer is running.

3) To stop the dryer, first stop the airflow (either shut-down the air compressor or close the inlet/outlet or by-pass valve) When the air flow is stopped, set the rotary switch on " 0 " Set it again on " I " in order to keep the preheating on.



IMPORTANT NOTE !

4) Avoid leaving the dryer stopped when compressed air is still flowing through it.

5) To switch the already preheated dryer on again, simply push the green start button.

4) ELECTRICAL CONTROLLER

4.1 DIGI-PRO

4.1.1 Description

With the Digi-Pro series controllers, air dryers have outstanding technology for both functionality and performance, as well as appearance. The multi-functional display provides an accurate digital dew point display as well as coded alarm monitoring of the refrigerant dryer.

DIGITAL CONTROLLER ADVANTAGES;

- Digital dew point monitoring
- Energy-saving mode display
- Periodic maintenance interval display
- Status report
- Run time meter
- Fahrenheit and Centigrade selection

4.1.2 Operation

Using the Digi Pro controller as shown in the picture below:



4.1.3 Menu Buttons



PROGRAM

To modify the parameter, press and release button set. The menu is used by service tech. To disable the Key Lock: Press and hold the SET for 4 sec.



POWER

This button is used for starting and stopping the dryer. Press and hold for 4 seconds to start or stop.



MENU

These buttons are used to navigate between screens and adjust values.



MANUAL DRAIN

This button is used for manual control of the drain output. Press and hold for 4 seconds to drain manually.

4.1.4 ALARM DISPLAY



Alarms / warnings are displayed on the digital screen. That means the dryer is not working under normal operating conditions, which are outside the range of set values.

Alarm Code	Alarm Description	Reason for Alarm
tAL	Low Temperature Alarm	Refrigerant line temperature is lower than specified set values
tAH	High Temperature Alarm	Refrigerant line temperature is higher than specified set values
FIL	Filter Change Alarm	Filter element needs to be replaced
SEr	General Service Alarm	General service time of the dryer
HP	High Pressure Alarm	Refrigerant high line pressure is higher than specified set values
Pr1	Temperature Probe Alarm	Temperature sensor is faulty.
tSH	High Suction Line Temp	Temperature of Refrigerant suction line is higher than specified set values



Please contact to the service when an alarm/warning occurs.

4.1.5 MODE DISPLAY



DRYER ACTIVE MODE

This mark indicates that the dryer is performed in active state and drying.



AUTOMATIC DRAIN MODE

Shows if the drain system is activated.



ENERGY SAVING MODE

Shows if the energy saving mode is activated



CELSIUS UNIT MODE

Indicates that Celsius temperature unit is selected.



FAHRENHEIT UNIT MODE

Indicates that Fahrenheit temperature unit is selected.



COMPRESSOR STANDBY MODE

This mode shows that the dryer is ready for drying operation.



SERVICE MODE

This mode shows that the dryer in the service time.

4.2 ESD 3

4.2.1 DESCRIPTION

E-687 is designed as a controller for refrigerant type compressed air dryers. The controller has 8 temperature sensor inputs.

The controller has an RS-485 communication interface that can be used for remotely monitoring channel temperatures, set points, input and output status. Modbus RTU protocol is used for communication.

The front panel of the controller contains a four line 20 character LCD display and buttons that are used in configuration and manual control operations.

The dimensions of the controller are 3.7 x 7.5 in. (front panel) with a depth of 4.3 in. . The panel cutout should be 3.5 x 7.2 in. . The operating voltage of the controller is 20 - 60V AC or 20 - 85V DC.

4.2.2 OPERATION

The front panel view of E-687 controller is shown in the below figure. The front panel of the controller contains a four line 20 character LCD display, 10 buttons and 2 indicator leds.

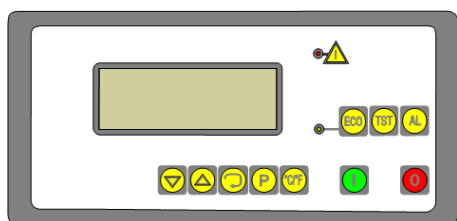

The Front Panel View of E-687 Controller

button is used to enable or disable the ECO (economy) mode. Pressing this button complements the state of ECO, i.e. if it is enabled; disables, if it is disabled; enables the ECO mode. The green led on the left side of the button lights if the ECO mode is enabled.

button is used for manual control of the drain output.

button is used for alarm acknowledge. The dryer is automatically stopped if an fault is detected. In that case, the alarm output and the alarm indicator led (red) on the front panel become activated. In order to restart the dryer, alarm should be acknowledged and "restart delay" period should be timed out. Pressing button acknowledges the alarm and reenergizes the alarm output and alarm led.

The buttons below the LCD display (, , and) are used in screen selection and configuration operations.

button is used to change the temperature unit from °C to °F or vice versa.

and buttons are used for starting and stopping the dryer. If the dryer is stopped manually, it can not be started before "restart delay" period is timed out.

, , , , and buttons are disabled during configuration operations.

4.2.3 OPERATION SCREENS

4.2.3.1 The Normal Operation Screen

When the controller is powered on, it displays the type and a message, and then the restart delay timer is set to 5 seconds. After 5 seconds, the normal operation screen is displayed as shown in below figure

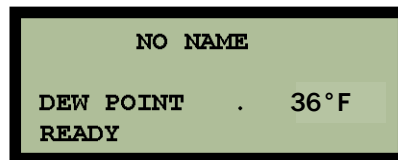

The exchanger temperature (Dew Point) and operation state of the dryer is displayed in this screen. If there is a situation which will prevent the operation of the dryer then the "READY" message in the last line will become "DISABLED". See below figure

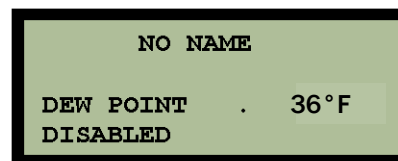

In order to start the dryer, the following conditions must be satisfied.

1. All the temperatures except the exchanger temperature and condenser outlet temperature must be between their low and high limits. The low pressure line temperature can be 'HIGH'.
2. Digital Input 3 (Compressor Fault) is not activated.
3. Digital Input 4 (Compressor Overload) is not activated.
4. Digital Input 5 (Fan Fault) is not activated.
5. Digital Input 6 (Fan Overload) is not activated.
6. Digital Input 7 (Phase Sequence Error) is not activated.
7. Digital Input 8 (Remote Disable) is not activated.
8. Digital Input 11 (High Pressure) is not activated.
9. Digital Input 12 (Low Pressure) is not activated.

If all the above conditions are checked, the message in the last line of the normal operation screen will be "READY" and the dryer can be started either pressing button on the front panel or activating Digital Input 1 (Remote Start) or activating Digital Input 13 (Remote Control). When the dryer is started, the normal operation screen is displayed as shown in below figure.

```

NO NAME
DEW POINT . 36°F
RUNNING DRAIN ON
  
```

In the beginning, Digital Output 1 (Compressor Motor), Digital Output 2 (Drain Output) and Digital Output 3 (Dryer is Running) become active. While in normal operation, the drain output is controlled according to the configured "drain on" and "drain off" periods. "DRAIN ON" message is displayed in the end of the last line while the drain output is active.

When the Digital Input 9 (Fan Motor is on) is activated, "FAN MOTOR IS ON" message is displayed in the second line as shown in below figure.

```

NO NAME
FAN MOTOR IS ON
DEW POINT . 36°F
RUNNING
  
```

Digital Input 14 (Water Pump is on) activates "WATER PUMP IS ON" message as shown in below figure.

```

NO NAME
WATER PUMP IS ON
DEW POINT . 36°F
RUNNING
  
```

When ECO mode is enabled and the exchanger temperature is less than or equal to "ECO Start Set point" and this condition is prevailed more than "ECO Start Delay", then, the compressor motor is stopped and ECO operation starts. During the ECO operation the appearance of the display is given in below figure. The value at the end of the second row indicates the time in seconds since beginning of the ECO operation.

```

NO NAME
ECO (SEC.) : 324
DEW POINT . 36°F
RUNNING
  
```

Pressing and keys simultaneously at this page toggles the controller between automatic and manual mode. In manual mode, the dryer starts and stops manually by using and buttons. Unlike the manual mode, automatic mode enables the controller start and stop automatically at pre-programmed times on a daily basis

When running in automatic mode, current scheduling information messages are also activated in the second line of the displays as show in below figure. "NOT SCHEDULED" message is displayed when no schedule exists. "START IN XXX" shows the time to the next scheduled program in minutes and "STOP IN XXX" message shows the time to the end of current running program in minutes.

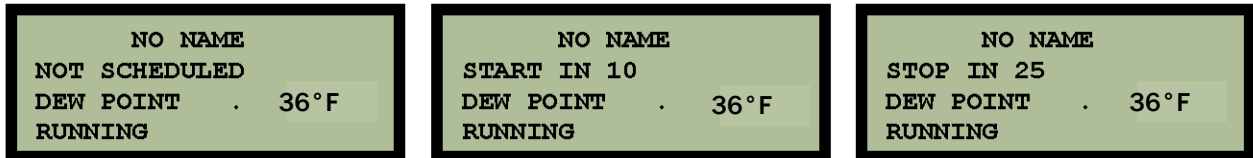

If the dryer is stopped manually by using button, or activating Digital Input 2 (Remote Stop) or deactivating Digital Input 13 (Remote Control), the normal operating screen is displayed as shown in below figure. The number at the end of the last line indicates the remaining time in seconds from the restart delay. If this number becomes zero and there is no anomaly, the dryer can be restarted.

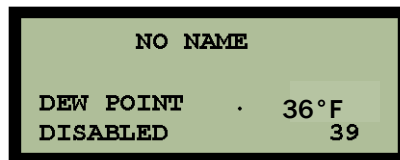

The first line in the normal operation screen (NO NAME) is user configurable. If the exchanger temperature sensor is broken, dew point temperature will be displayed as 1000°C.

4.3.3. The Info Screens

Various data related to the dryer can be monitored by sequentially pressing button. Pressing button, changes the display screen. While one screen is displayed, pressing button reverts to the normal operation screen. The flow chart for monitoring the dryer data is given in Figure 2.13. In this figure, screen numbers are shown on the upper left of the screens.

Screen1 is the normal operation screen. While this screen is displayed, pressing button selects Screen2. By successively pressing button, all the screens can be accessed. Screens may also be selected by and buttons.

In Screen2, Screen3 and Screen4, the sensor temperatures are displayed. If the measured temperatures are between their low and high limits, only the temperature value is displayed, otherwise "LOW" or "HIGH" message is added in the end of the line. In case of sensor break, only "SENSOR BREAK" message is displayed.

In screen 5 and 6 the states of the compressor motor, fan motor, the phase sequence, remote disable and air pressure are displayed. Actually this data is derived from the digital inputs.

The message in the first line of Screen5 is determined by Digital Input 3 and Digital Input 4 (Compressor Fault and Compressor Overload). in the below table shows the relation between digital inputs and the message.

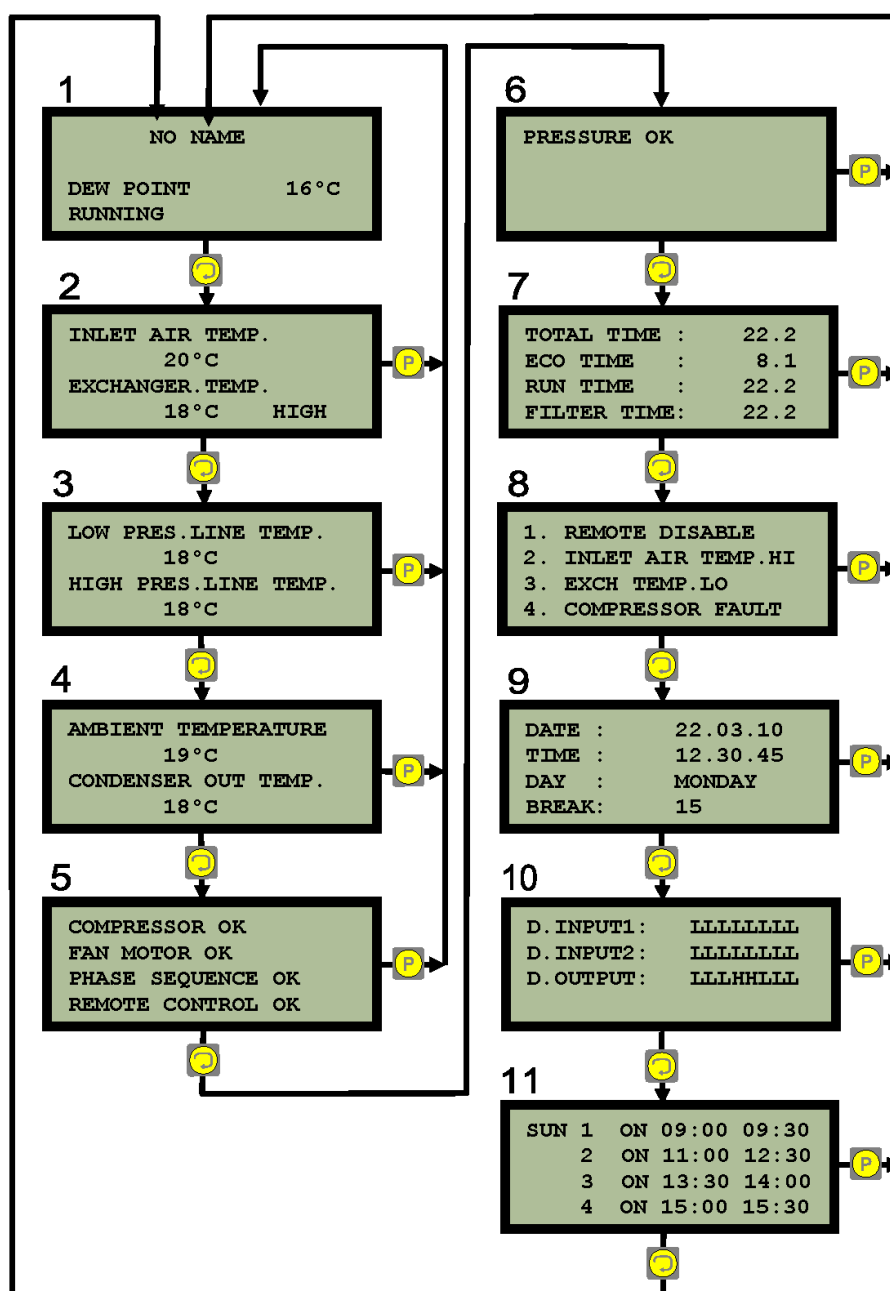

Screen8 displays the last four events that caused the dryer stopping automatically. The possible alternatives for these messages are given below.

INLET AIR TEMP.LO	COMPRESSOR FAULT
INLET AIR TEMP.HI	COMP.OVERLOAD
EXCH.TEMP.LO	FAN MOTOR FAULT
EXCH.TEMP.HI	FAN MOT.OVERLOAD
LO.PRES.L.TEMP.LO	PHASE SEQ.ERROR
LO.PRES.L.TEMP.HI	REMOTE DISABLE
HI.PRES.L.TEMP.LO	PRESSURE HIGH
HI.PRES.L.TEMP.HI	PRESSURE LOW
AMB.TEMP.LO	CONDENSER FAULT
AMB.TEMP.HI	

Screen9 displays the date and time.

Screen10 displays the states of the digital inputs and digital outputs. The letters 'L' and 'H' stands for 'not activated' and 'activated' states respectively.

The data in the first line of Screen10 (D.INPUT1), from right to left corresponds to Digital Input 1 to 8.

The data in the second line of Screen10 (D.INPUT2), from right to left corresponds to Digital Input 9 to 16.

The data in the third line of Screen10 (D.OUTPUT), from right to left corresponds to Digital Output 1 to 8.

Screen11 displays automatic mode scheduling for the day. Please see Section 2.3.3 for scheduling for auto/manual selection.

4.3.4 Operation Principles

In order to start the dryer, the following conditions must be satisfied.

1. All the temperatures except the exchanger temperature and condenser outlet temperature must be between their low and high limits. The low pressure line temperature can be 'HIGH'.
2. Digital Input 3 (Compressor Fault) is not activated.
3. Digital Input 4 (Compressor Overload) is not activated.
4. Digital Input 5 (Fan Fault) is not activated.
5. Digital Input 6 (Fan Overload) is not activated.
6. Digital Input 7 (Phase Sequence Error) is not activated.
7. Digital Input 8 (Remote Disable) is not activated.
8. Digital Input 11 (High Pressure) is not activated.
9. Digital Input 12 (Low Pressure) is not activated.

If all the above conditions are satisfied, the dryer can be started.

5. TECHNICAL SPECIFICATIONS

Model	Model	Capacity (scfm)	Pressure drop (psig)	Connection Size	Amount of Refrigerant (pounds)	Refrigerant gas	Noise Level (dB)
PDRCF1150029	EDRCF1150030	29	2,8	1/2" NPT	0.7	R134a	<70
PDRCF1150058	EDRCF1150058	50	1,6	3/4" NPT	1.2	R134a	<70
PDRCF1150115	EDRCF1150115	115	1,6	1 1/2" NPT	2.2	R134a	<70
PDRCF1150144	EDRCF1150144	144	2,2	1 1/2" NPT	2.2	R134a	<70
PDRCF2300288	EDRCF2300288	288	2,2	2" NPT	5.5	R134a	<70
PDRCF4600288	EDRCF4600288	288	2,2	2" NPT	5.5	R134a	<70
PDRCF2300575	EDRCF2300575	600	3,3	3" NPT	15.4	R134a	<70
PDRCF4600575	EDRCF4600575	600	3,3	3" NPT	15.4	R134a	<70
PDRCF4600850	EDRCF4600850	1000	2,2	3" NPT	22	R134a	<70
PDRCF4601200	EDRCF4601200	1200	2,7	3" NPT	22	R134a	<70
PDRCF4601600	EDRCF4601600	1750	4,1	DN100 Flange	23.1	R134a	<70
PDRCF4602000	EDRCF4602000	2250	3,8	DN100 Flange	44	R134a	<70

FOR ALL MODELS	
Nominal Working Pressure	100 psig
Maximum Working Pressure	230 psig
Maximum Ambient Temperature	122°F
Minimum Ambient Temperature	39°F
Maximum Inlet Temperature	140°F

6. DIAGRAMS

6.1 AIR FLOW DIAGRAMS

PDRCF1150029 / EDRCF1150030 - PDRCF4600575 / EDRCF4600575

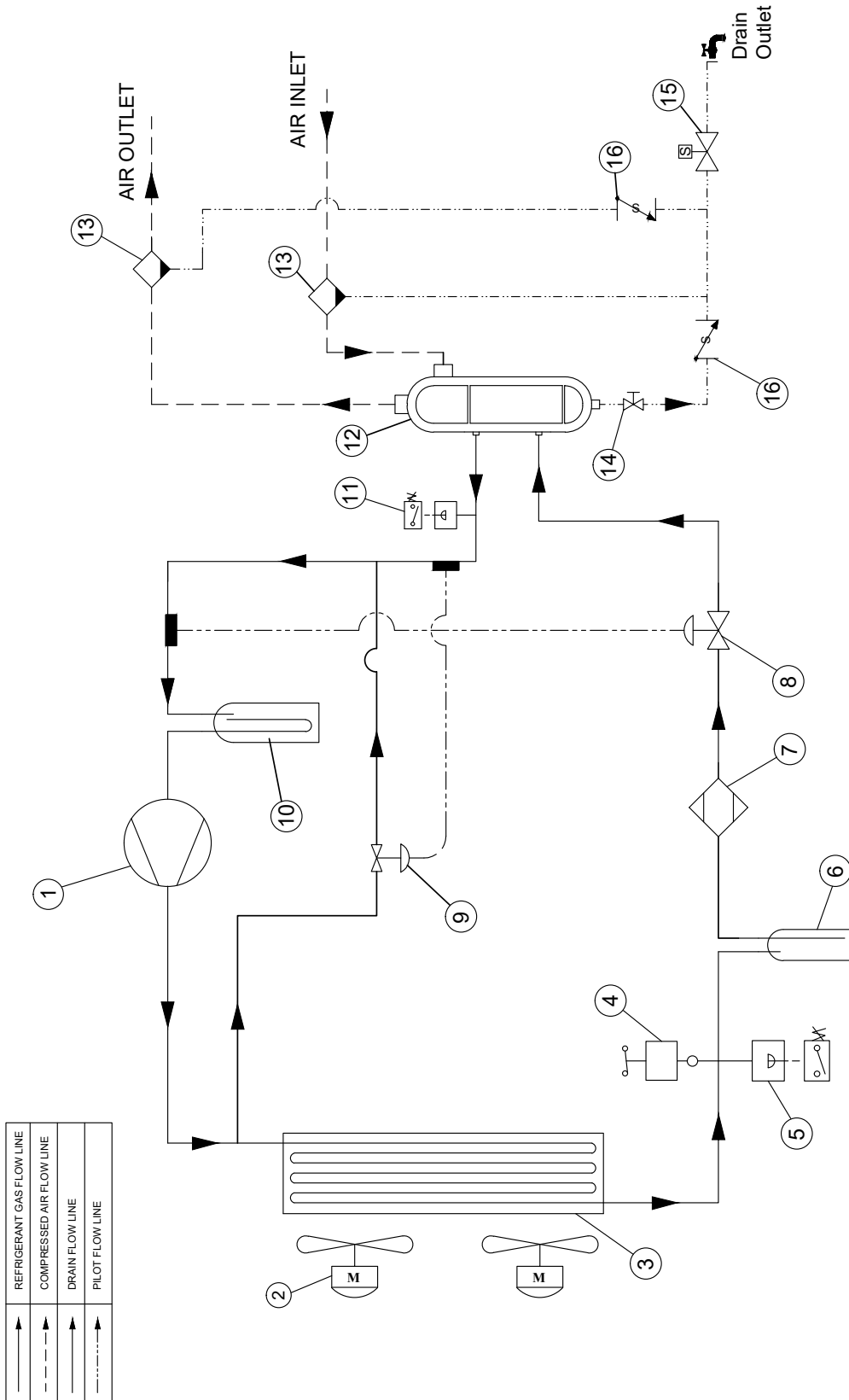

IMPORTANT NOTICE:

- High Pressure Switch (Part No:5) is not used PDRCF1150029 & EDRCF1150030 .
- Hot Gas By Pass Valve (Part No:9) are not used PDRCF1150029 & EDRCF1150030 .
PDRCF1150058 & EDRCF1150058.
- Liquid Receiver (Part No:6) is not used from PDRCF1150029 & EDRCF1150030
to PDRCF1150144 & EDRCF1150144
- Liquid Separator (Part No:10) is used PDRCF2300575 & EDRCF2300575.
PDRCF4600575 & EDRCF4600575.
- Low Pressure Switch (Part No:11) is only PDRCF2300575 & EDRCF2300575 .
PDRCF4600575 & EDRCF4600575 .

6.1 AIR FLOW DIAGRAMS

PDRCF1150029 / EDRCF1150030 - PDRCF4600575 / EDRCF4600575

POS.	DESCRIPTION	QTY
1	COMPRESSOR	
2	FAN MOTOR	
3	CONDENSER	
4	FAN SWITCH	
5	HIGH PRESSURE SWITCH	
6	LIQUID RECEIVER	
7	FILTER DRIER	
8	EXPANSION VALVE	
9	BY-PASS VALVE	
10	LIQUID SEPARATOR	
11	LOW PRESSURE SWITCH	
12	HEAT EXCHANGER	
13	FILTER	
14	MANUEL VALVE	
15	SOLENOID VALVE	
16	CHECK VALVE	

6.1 AIR FLOW DIAGRAMS

PDRCF4600850 / EDRCF4600850 - PDRCF4602000 / EDRCF4602000

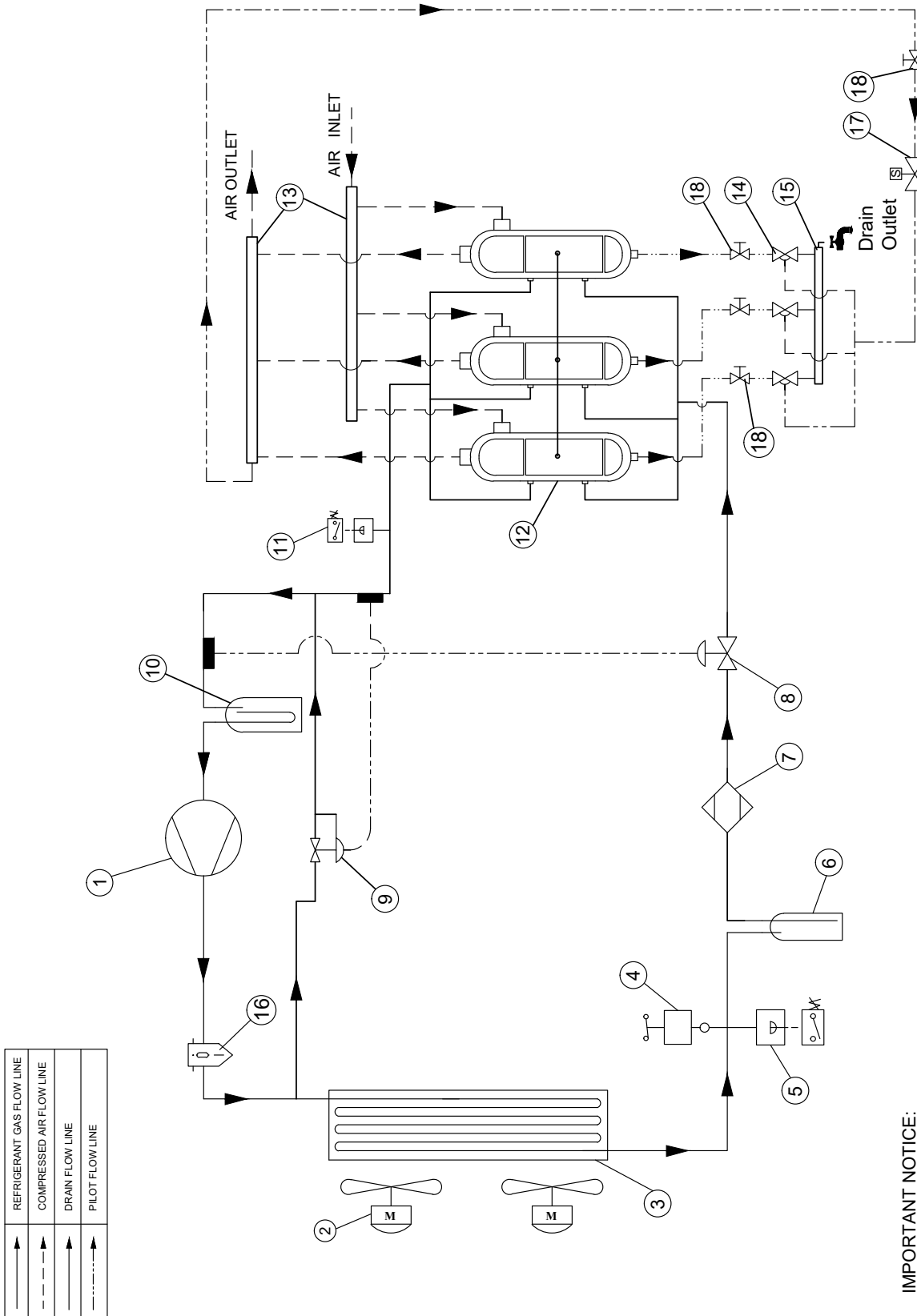

6.1 AIR FLOW DIAGRAMS

PDRCF4600850 / EDRCF4600850 - PDRCF4602000 / EDRCF4602000

POS.	DESCRIPTION	QTY
1	COMPRESSOR	
2	FAN MOTOR	
3	CONDENSER	
4	FAN SWITCH	
5	HIGH PRESSURE SWITCH	
6	LIQUID RECEIVER	
7	FILTER DRIER	
8	EXPANSION VALVE	
9	BY-PASS VALVE	
10	LIQUID SEPARATOR	
11	LOW PRESSURE SWITCH	
12	HEAT EXCHANGER	
13	AIR COLLECTOR	
14	MEMBRANE VALVE	
15	DRAIN COLLECTOR	
16	OIL SEPARATOR	
17	SELONOID VALVE	
18	MANUEL VALVE	

6.2

PDRCF / EDRCF ELECTRICAL DIAGRAMS With Control & Power

“User must supply the protective earth conductor of the dryer. The conductor is to be connected to the point on the conducting body of the dryer, specified by a sticker with the protective earth symbol next to it. The size of the protective earth conductor should be minimum the size of the power conductor, minimum 16 mm² for power conductor size between 16 and 35 mm², minimum half the size of the conductor if it is larger than 35 mm².”

MODEL	MODEL	Voltage/Phase/ Hertz	INSTALLED POWER (kWatt)	Nominal Current (Amp)	MCA (A)	TOTAL LRA (A)	Fuse (Amp)
PDRCF1150029	EDRCF1150030	115/1P/60	0,42	3,92	5,11	22,48	6
PDRCF1150058	EDRCF1150058	115/1P/60	0,69	7,42	9,20	33,70	10
PDRCF1150115	EDRCF1150115	115/1P/60	0,96	10,87	13,45	48,70	15
PDRCF1150144	EDRCF1150144	115/1P/60	1,22	14,30	17,83	64,70	20
PDRCF2300288	EDRCF2300288	230/1P/60	1,95	8,5	13,63	56,8	15
PDRCF4600288	EDRCF4600288	460/3P/60	2,03	4,2	6,06	24,1	6
PDRCF2300575	EDRCF2300575	230/3P/60	3,56	11,26	21,04	93,66	25
PDRCF2300575	EDRCF2300575	460/3P/60	3,63	6,68	11,26	52,38	15
PDRCF4600850	EDRCF4600850	460/3P/60	5,49	11,22	16,85	103,22	20
PDRCF4601200	EDRCF4601200	460/3P/60	6,14	13,32	17,60	98,22	20
PDRCF4601600	EDRCF4601600	460/3P/60	8,40	16,20	27,58	130,20	30
PDRCF4602000	EDRCF4602000	460/3P/60	10,77	21,00	35,00	157,00	35

6.2 ELECTRICAL DIAGRAMS

PDRCF1150029 / EDRCF1150030

EV3: Controller
 SP: Power supply
 AL: Alarm contacts
 A20: Drain supply
 DR: Drain valve relay
 A40-I: Start capacitor
 K01: Compressor start relay
 K02: Compressor motor contactor
 K30: Alarm relay
 S10: Fan pressure switch
 S16: Filter service contact (optional)
 M01: Compressor motor
 M10: Fan motor
 P: Compressor motor overload protector
 PT: Temperature sensor (NTC)
 IHP: indicates high pressure.

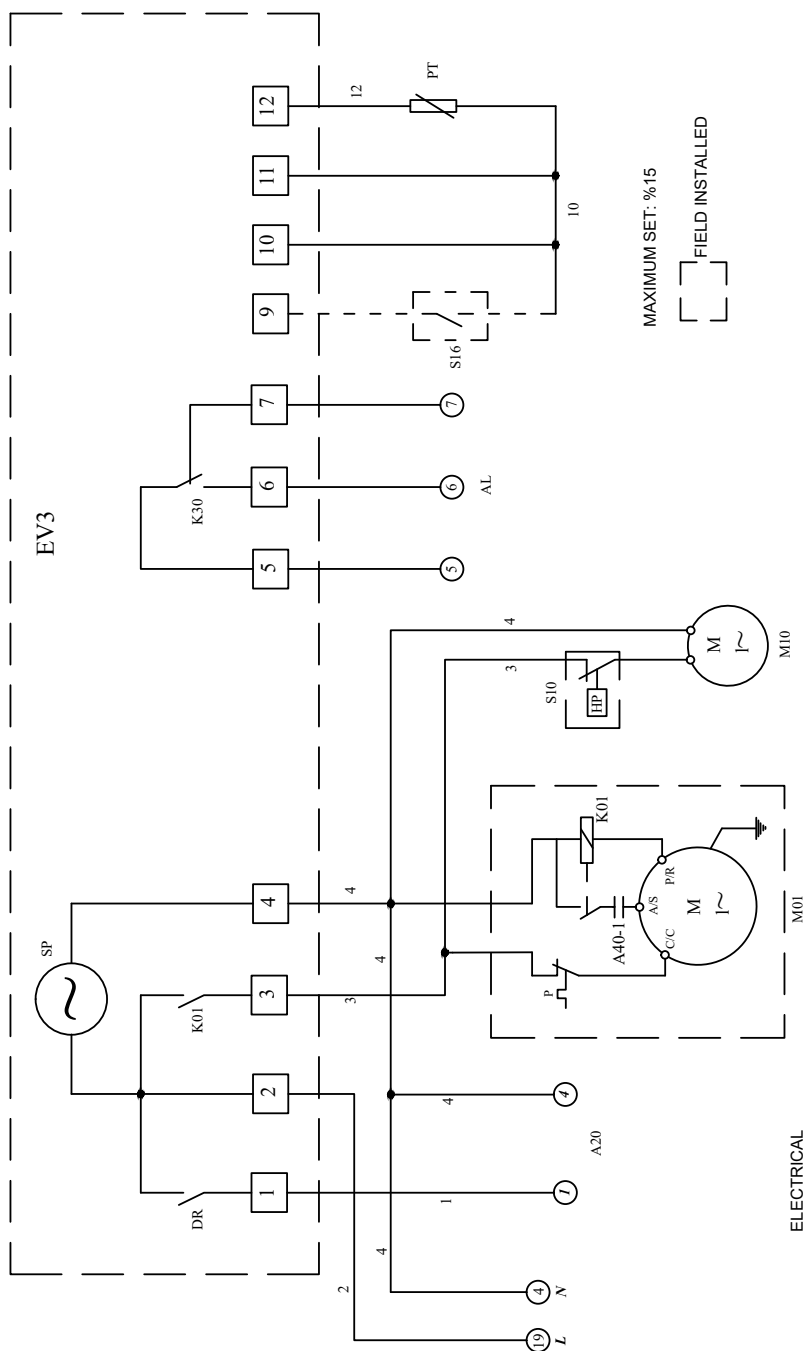

MAXIMUM SET: %15

FIELD INSTALLED

S01 MAIN PROTECTION AND DISCONNECTING MEANS SHALL BE PROVIDED BY THE INSTALLER OF RESIDUAL CURRENT AUTOMATIC CIRCUIT BREAKER

SUPPLY LINE VOLTAGE RATING - 600 VAC

ELECTRICAL SUPPLY LINE SINGLE PHASE + PROTECTION EARTH
CABLES SIZE
PDRCF1150029 3AWG14
EDRCF1150030 3AWG14

ELECTRICAL SPECIFICATIONS

COMPRESSOR UN 115V/1~60Hz
 PDRCF1150029 RLA 3,7A 0,285kW PDRCF1150029 RLA 0,35A 0,055kW
 EDRCF1150030 RLA 3,7A 0,285kW EDRCF1150030 RLA 0,35A 0,055kW

FAN MOTOR UN 115V/1~60Hz

6.2 ELECTRICAL DIAGRAMS

PDRCF1150058 / EDRCF1150058 to PDRCF1150144 / EDRCF1150144

- EV3: Controller
- SP: Power supply
- AL: Alarm contacts
- A20: Drain supply
- DR: Drain valve relay
- A40-1: Start capacitor
- K01: Compressor start relay
- K02: Compressor motor contactor
- K30: Alarm relay
- S10: Fan pressure switch
- S11: High pressure switch
- S16: Filter service contact (optional)
- M01: Compressor motor
- M10: Fan motor
- P: Compressor motor overload protector
- PT: Temperature sensor (NTC)
- HP: Indicates high pressure

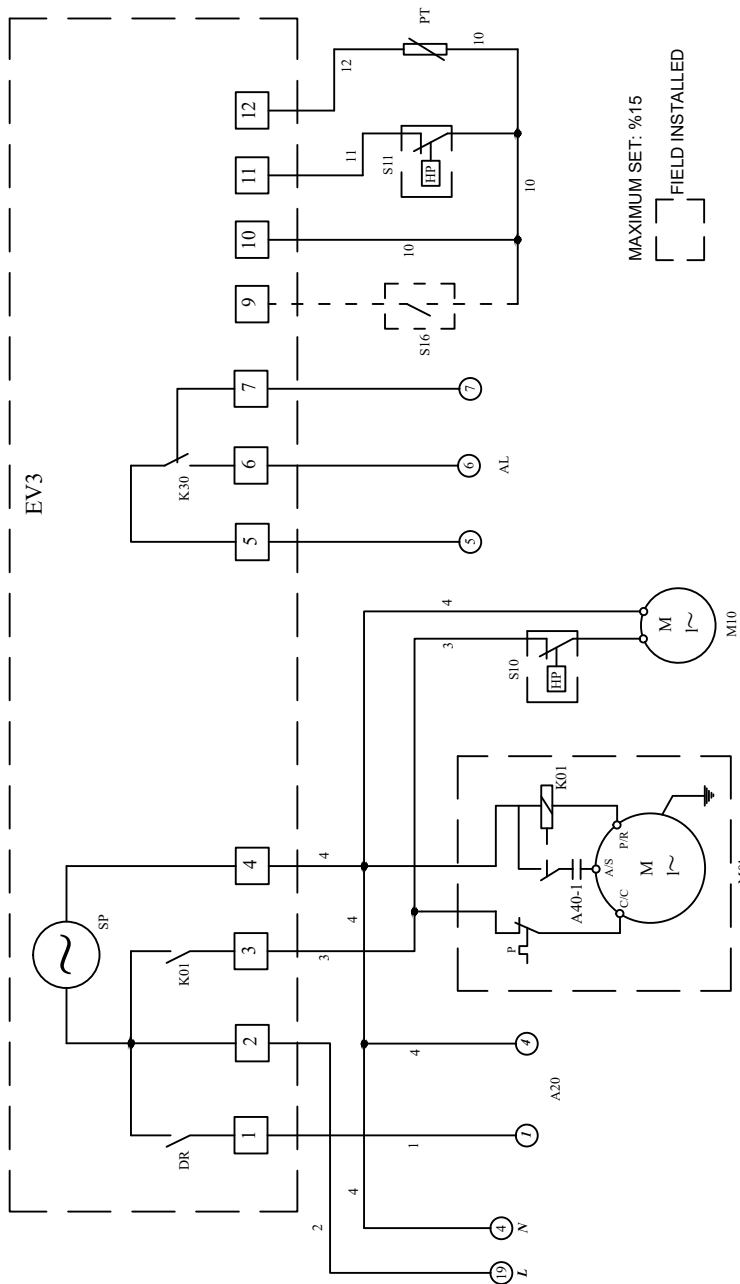

MAXIMUM SET: %15
FIELD INSTALLED

S01 MAIN PROTECTION AND DISCONNECTING MEANS SHALL BE PROVIDED BY THE INSTALLER OF RESIDUAL CURRENT AUTOMATIC CIRCUIT BREAKER

SUPPLY LINE VOLTAGE RATING - 600 VAC

ELECTRICAL SUPPLY LINE SINGLE PHASE + PROTECTION EARTH	CABLES SIZE
PDRCF1150058	3AWG14
PDRCF1150115	3AWG14
PDRCF1150144	3AWG14
EDRCF1150058	3AWG14
EDRCF1150115	3AWG14
EDRCF1150144	3AWG14

ELECTRICAL SPECIFICATIONS

COMPRESSOR	FAN MOTOR
UN 115V/1~/60Hz	UN 115V/1~/60Hz
PDRCF1150058 RLA 6A 0,466kW	PDRCF1150058 RLA 0,95A 0,110kW
PDRCF1150115 RLA 9,4A 0,725kW	PDRCF1150115 RLA 0,95A 0,110kW
PDRCF1150144 RLA 12,9A 0,964kW	PDRCF1150144 RLA 0,95A 0,110kW
EDRCF1150058 RLA 6A 0,466kW	EDRCF1150058 RLA 0,95A 0,110kW
EDRCF1150115 RLA 9,4A 0,725kW	EDRCF1150115 RLA 0,95A 0,110kW
EDRCF1150144 RLA 12,9A 0,964kW	EDRCF1150144 RLA 0,95A 0,110kW

6.2 ELECTRICAL DIAGRAMS

PDRCF2300288 / EDRCF2300288 POWER

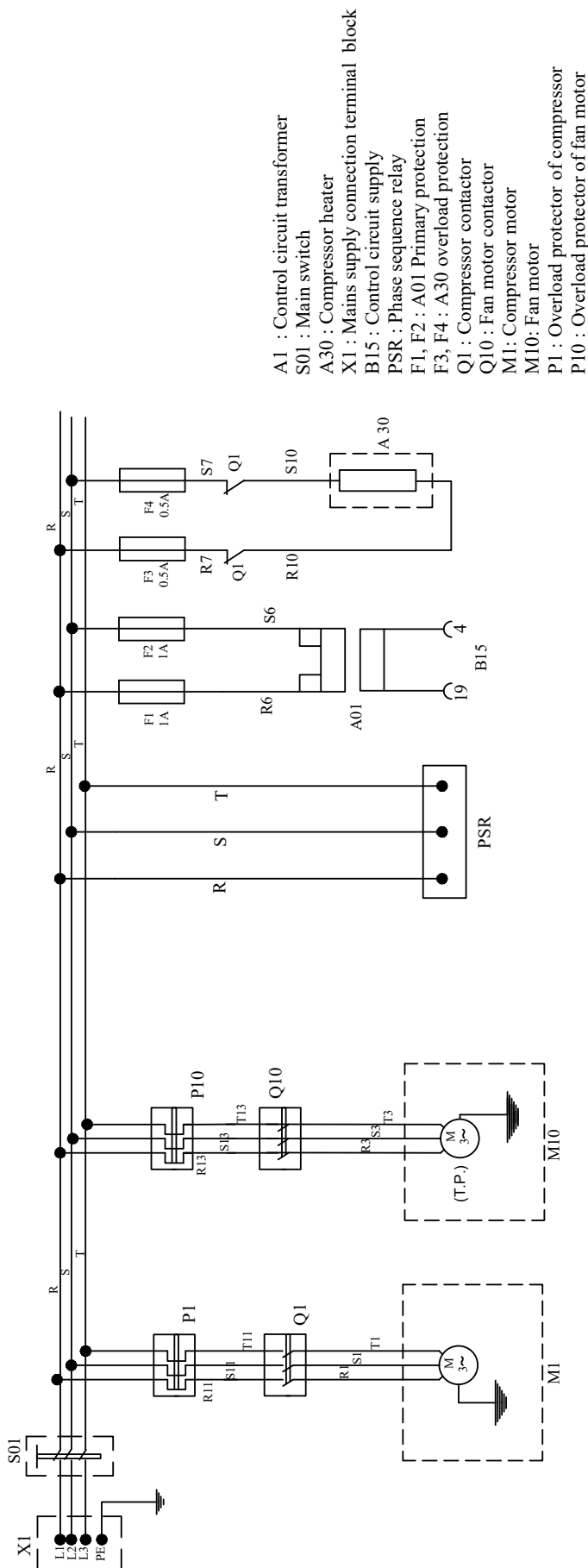

- A1 : Control circuit transformer
- S01 : Main switch
- A30 : Compressor heater
- X1 : Mains supply connection terminal block
- B15 : Control circuit supply
- PSR : Phase sequence relay
- F1, F2 : A01 Primary protection
- F3, F4 : A30 overload protection
- Q1 : Compressor contactor
- Q10 : Fan motor contactor
- M1 : Compressor motor
- M10 : Fan motor
- P1 : Overload protector of compressor
- P10 : Overload protector of fan motor

MAIN PROTECTION AND DISCONNECTING MEANS SHALL BE PROVIDED BY THE INSTALLER OF RESIDUAL CURRENT AUTOMATIC CIRCUIT BREAKER

SUPPLY LINE VOLTAGE RATING - 600 VAC

ELECTRICAL SUPPLY LINE 3 PHASE + PROTECTION EARTH	
PDRCF2300288	CABLES SIZE 4AWG14
EDRCF2300288	4AWG14

ELECTRICAL SPECIFICATIONS

COMPRESSOR	FAN MOTOR
UN 230V/3~60Hz	UN 230V/3~60Hz
PDRCF2300288 RLA 6.2A 1,589kW	PDRCF2300288 RLA 0.65A 0,125kW
EDRCF2300288 RLA 6.2A 1,589kW	EDRCF2300288 RLA 0.65A 0,125kW

6.2 ELECTRICAL DIAGRAMS PDRCF4600288 / EDRCF4600288 POWER

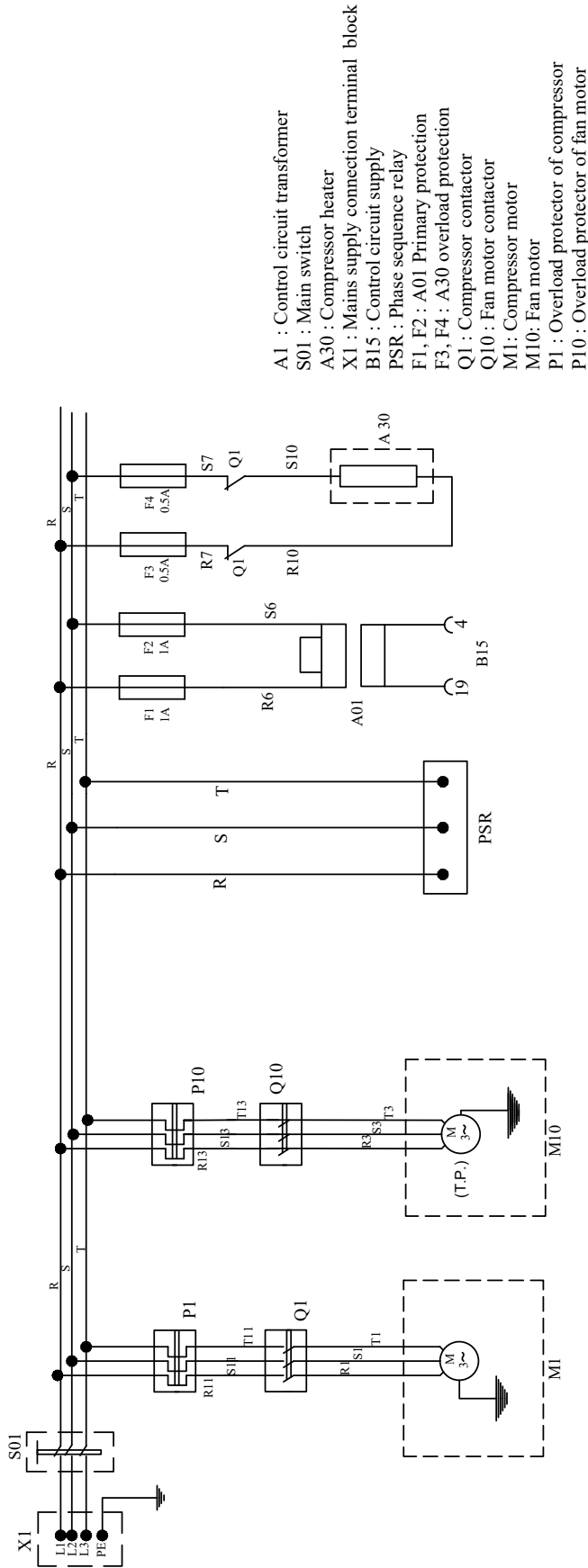

- A1 : Control circuit transformer
- S01 : Main switch
- A30 : Compressor heater
- X1 : Mains supply connection terminal block
- B15 : Control circuit supply
- PSR : Phase sequence relay
- F1, F2 : A01 Primary protection
- F3, F4 : A30 overload protection
- Q1 : Compressor contactor
- Q10 : Fan motor contactor
- M1 : Compressor motor
- M10 : Fan motor
- P1 : Overload protector of compressor
- P10 : Overload protector of fan motor

ELECTRICAL SPECIFICATIONS

COMPRESSOR	FAN MOTOR
UN 460V/3~/60Hz	UN 460V/3~/60Hz
PDRCF4600288 RLA 6.2A 1,589kW	PDRCF4600288 RLA 0.34A 0.125kW
EDRCF4600288 RLA 6.2A 1,589kW	EDRCF4600288 RLA 0.34A 0.125kW

MAIN PROTECTION AND DISCONNECTING MEANS SHALL BE PROVIDED BY THE INSTALLER OF RESIDUAL CURRENT AUTOMATIC CIRCUIT BREAKER

SUPPLY LINE VOLTAGE RATING - 600 VAC

ELECTRICAL SUPPLY LINE 3 PHASE + PROTECTION EARTH	CABLES SIZE 4AWG14 4AWG14
--	---------------------------------

6.2 ELECTRICAL DIAGRAMS

PDRCF4600288 / EDRCF4600288 CONTROL

- EV3: Controller
- SP: Power supply
- AL: Alarm contacts
- A20: Drain supply
- DR: Drain valve relay
- PSR: Phase sequence relay
- F10: Control circuit fuse
- Q1: Compressor contactor
- Q10: Fan motor contactor
- K01: Compressor relay
- K30: Alarm relay
- S10: Fan pressure switch
- S12: High pressure switch
- S13: Low pressure switch
- S20: High temperature switch
- S16: Filter service contact (optional)
- S31: Fan thermal protector (optional)
- P1: Compressor overload protector
- P10: Fan overload protector
- PT: Temperature sensor (NTC)
- HP: indicates high pressure
- LP: indicates low pressure
- TH: indicates thermal

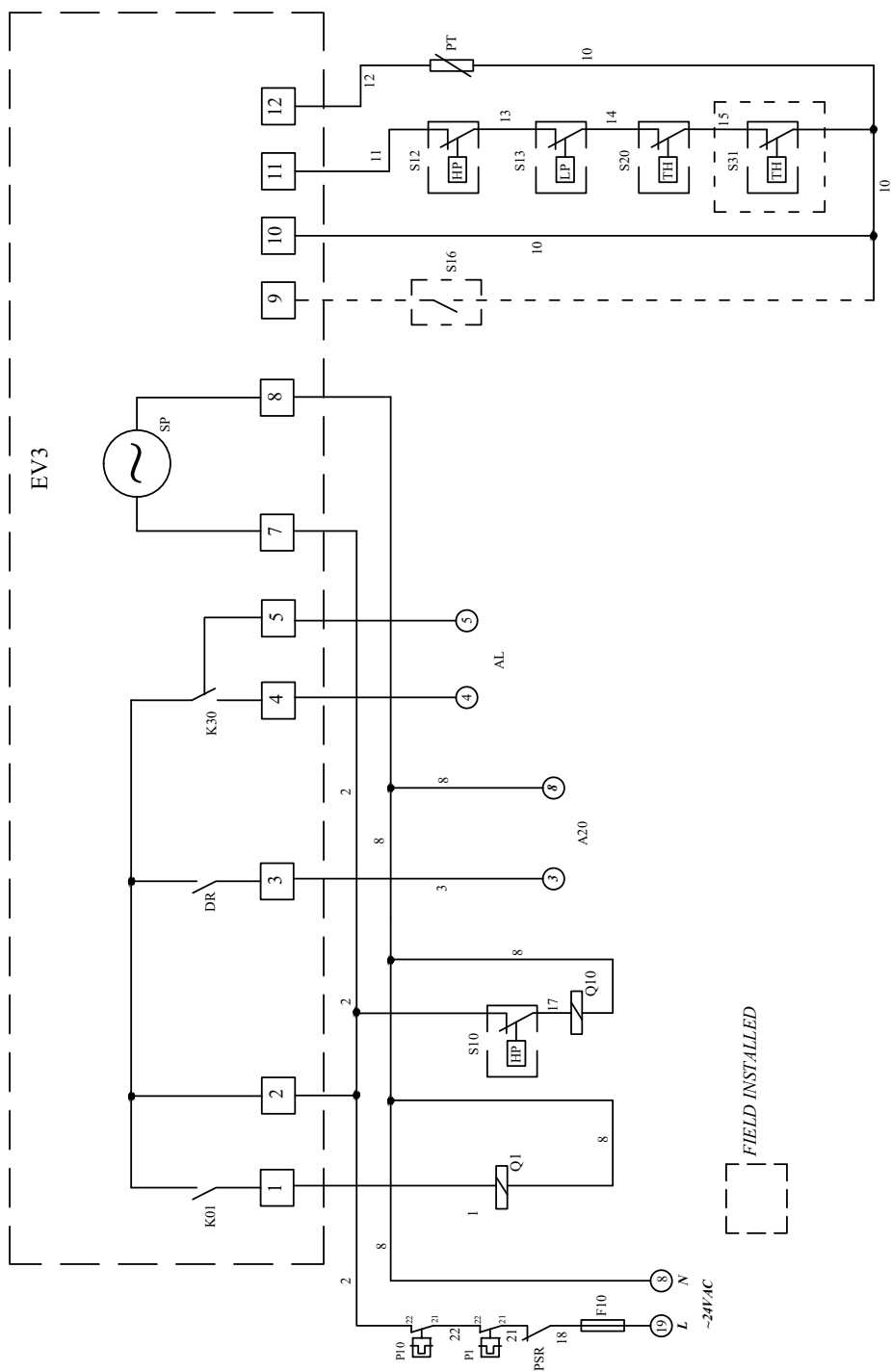

6.2 ELECTRICAL DIAGRAMS

PDRCF2300575 / EDRCF2300575 to PDRCF4601600 / EDRCF4601600 CONTROL

- F10, F11 : Control circuit protection
- S2: Limit Switch
- S5 : Remote control start button
- S7 : Remote control stop button
- S3 : Emergency Button
- S16: Filler service contact
- P1 : Overload protector of compressor
- P10 : Overload protector of fan motor 1
- P11 : Overload protector of fan motor 2
- S31: Fan heat thermal 1
- S32: Fan heat thermal 2
- EMR4 : Phase protection relay
- S8: Remote control contact
- S9: Obstruction for manual on/off
- S15 : Service contact
- S10 : Fan pressure switch
- S12 : High Pressure safety switch
- S13 : Low Pressure safety switch
- Q1 : Compressor motor contactor
- Q10 : Fan motor contactor 1
- Q11 : Fan motor contactor 2
- A20 : Electronic timer-drain supply (Optional)
- A21: Drain test
- A11 : Remote control running lamp (green)
- A13 : Remote control stand-by lamp (red)
- A41 : Remote control alarm contact
- PT1 : Inlet air temperature sensor (PT100)
- PT2 : Heat exchanger temperature sensor (PT100)
- PT3 : Low pressure line sensor (PT100)
- PT4 : High pressure line sensor (PT100)
- PT5 : Ambient temperature sensor (PT100)
- PT6 : Condenser outlet temperature sensor (PT100)
- B16 : Computer/Communication connection (RS 485)
- B17 : Dew point analog output (4-20mA (0-100 C))
- HP indicates high pressure
- LP indicates low pressure
- TH indicates thermal

- PDRCF2300575
- EDRCF2300575
- PDRCF4600575
- PDRCF4600850
- PDRCF4601200
- PDRCF4601600
- EDRCF4600575
- EDRCF4600850
- EDRCF4601200
- EDRCF4601600

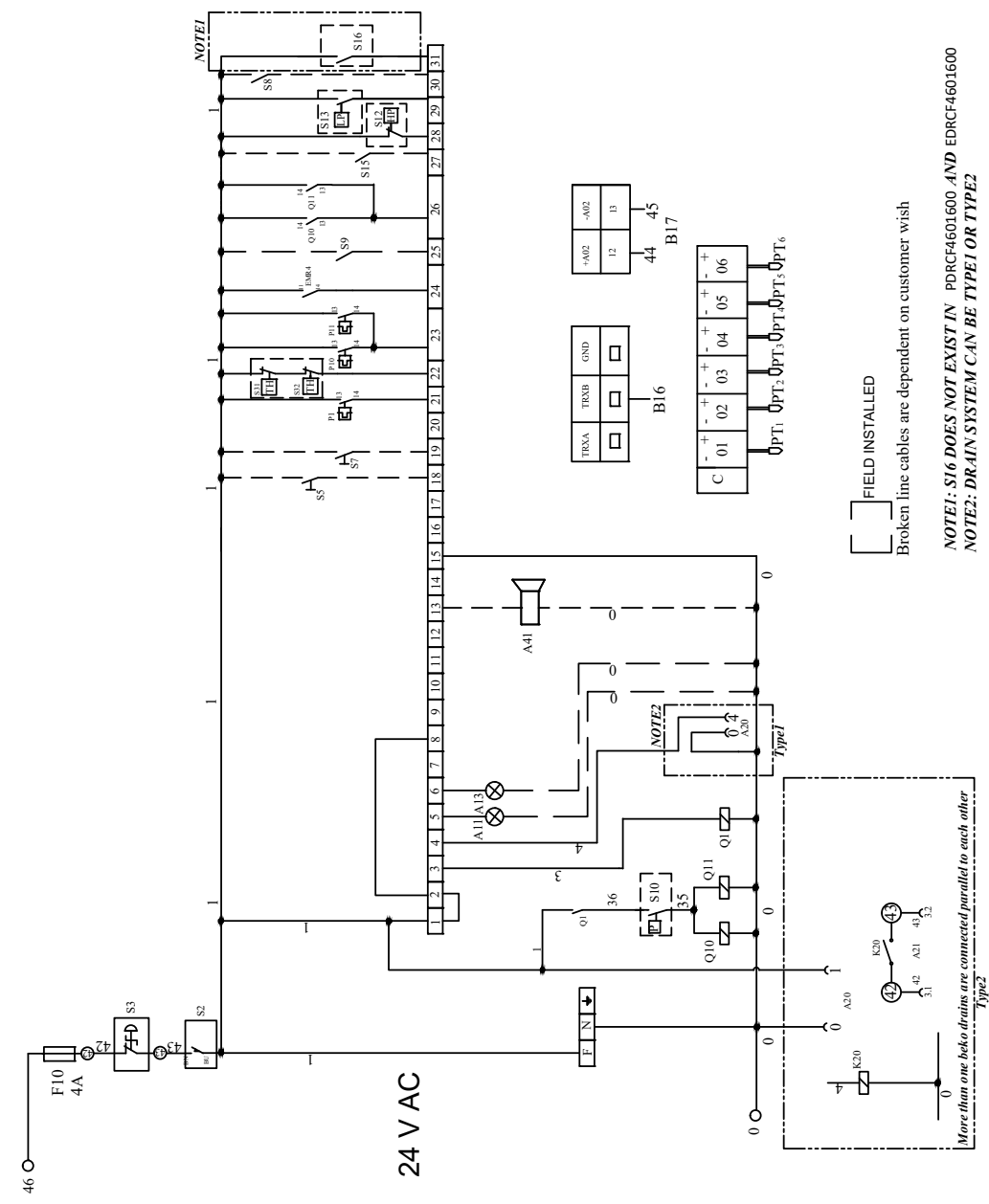

6.2 ELECTRICAL DIAGRAMS

PDRCF2300575 / EDRCF2300575 to PDRCF4601600 / EDRCF4601600 POWER

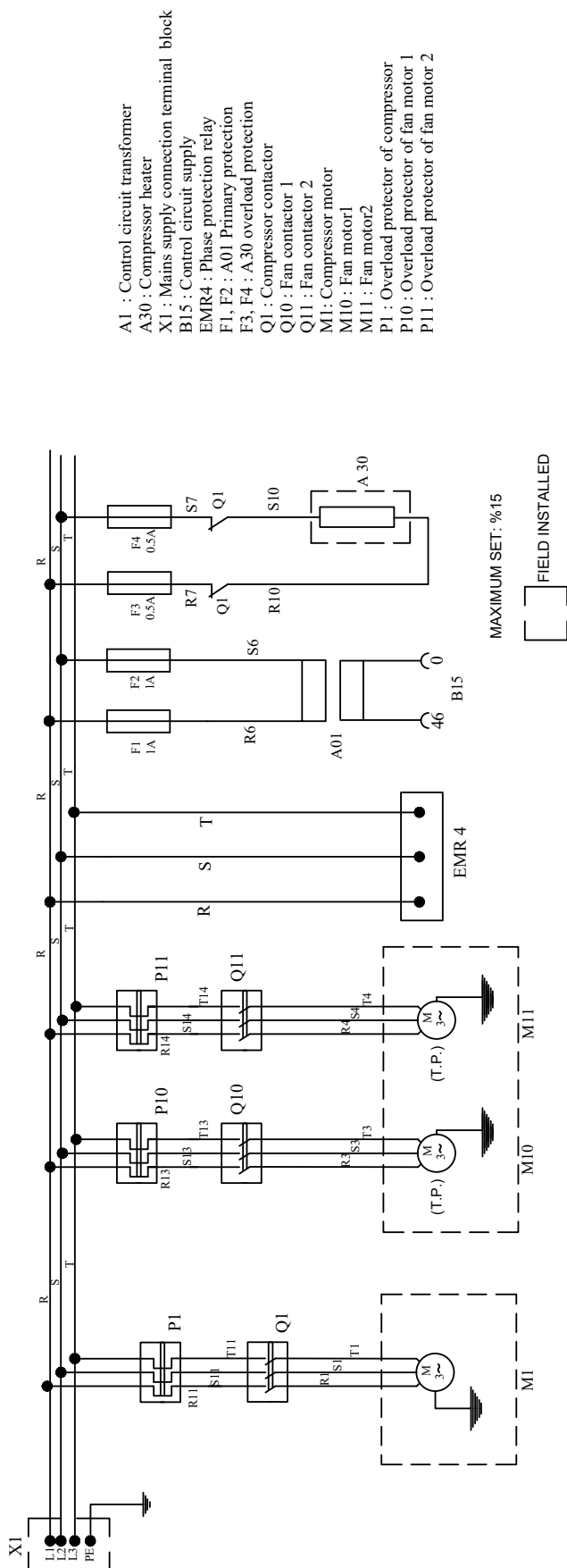

- A1 : Control circuit transformer
- A30 : Compressor heater
- X1 : Mains supply connection terminal block
- B15 : Control circuit supply
- EMR4 : Phase protection relay
- F1, F2 : A01 Primary protection
- F3, F4 : A30 overload protection
- Q1 : Compressor contactor
- Q10 : Fan contactor 1
- Q11 : Fan contactor 2
- M1 : Compressor motor
- M10 : Fan motor1
- M11 : Fan motor2
- P1 : Overload protector of compressor
- P10 : Overload protector of fan motor 1
- P11 : Overload protector of fan motor 2

6.2 ELECTRICAL DIAGRAMS

PDRCF4602000 / EDRCF4602000 CONTROL

- F10, F11 : Control circuit protection
- S2: Limit Switch
- S5 : Remote control start button
- S7 : Remote control stop button
- S3 : Emergency Button
- S16: Filter service contact
- P1 : Overload protector of compressor
- P10 : Overload protector of fan motor 1
- P11 : Overload protector of fan motor 2
- S31: Fan heat thermal 1
- S32: Fan heat thermal 2
- EMR4 : Phase protection relay
- S8 : Remote control contact
- S9 : Obstruction for manual on/off
- S15 : Service contact
- S10 : Fan pressure switch
- S12 : High Pressure safety switch
- S13 : Low Pressure safety switch
- V1: Bypass valve
- Q1 : Compressor motor contactor
- Q10 : Fan motor contactor 1
- Q11 : Fan motor contactor 2
- A20 : Electronic timer-drain supply (Optional)
- A25: Compressor heat thermal supply
- K20: Drain supply test relay
- A21: Drain test
- A11 : Remote control running lamp (green)
- A13 : Remote control stand-by lamp (red)
- A41 : Remote control alarm contact
- PT1 : Inlet air temperature sensor (PT100)
- PT2 : Heat exchanger temperature sensor (PT100)
- PT3 : Low pressure line sensor (PT100)
- PT4 : High pressure line sensor (PT100)
- PT5 : Ambient temperature sensor (PT100)
- PT6 : Condenser outlet temperature sensor (PT100)
- B16 : Computer/Communication connection (RS 485)
- B17 : Dew point analog output (4-20mA/0-100 C)
- HP indicates high pressure
- LP indicates low pressure
- TH indicates thermal

PDRCF4602000
EDRCF4602000

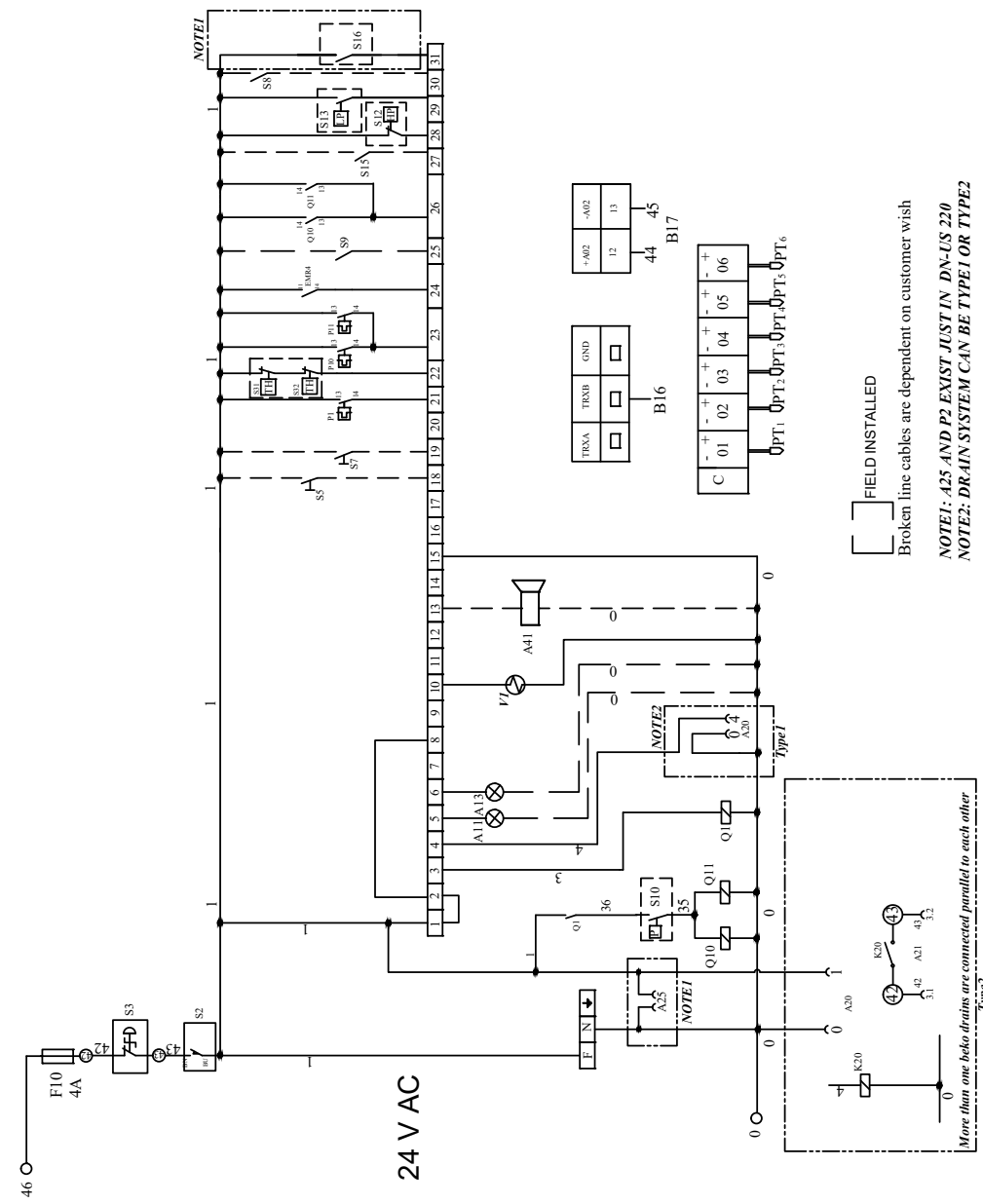

NOTE1: A25 AND P2 EXIST JUST IN DN-US 220
NOTE2: DRAIN SYSTEM CAN BE TYPE 1 OR TYPE 2

FIELD INSTALLED

Broken line cables are dependent on customer wish

6.2 ELECTRICAL DIAGRAMS

PDRCF4602000 / EDRCF4602000 POWER

- A1 : Control circuit transformer
- A30 : Compressor heater
- X1 : Mains supply connection terminal block
- B15 : Control circuit supply
- EMR4 : Phase protection relay
- F1, F2 : A01 Primary protection
- F3, F4 : A30 overload protection
- Q1 : Compressor contactor
- Q10 : Fan contactor 1
- Q11 : Fan contactor 2
- M1 : Compressor motor
- M10 : Fan motor1
- M11 : Fan motor2
- P1 : Overload protector of compressor
- P10 : Overload protector of fan motor 1
- P11 : Overload protector of fan motor 2

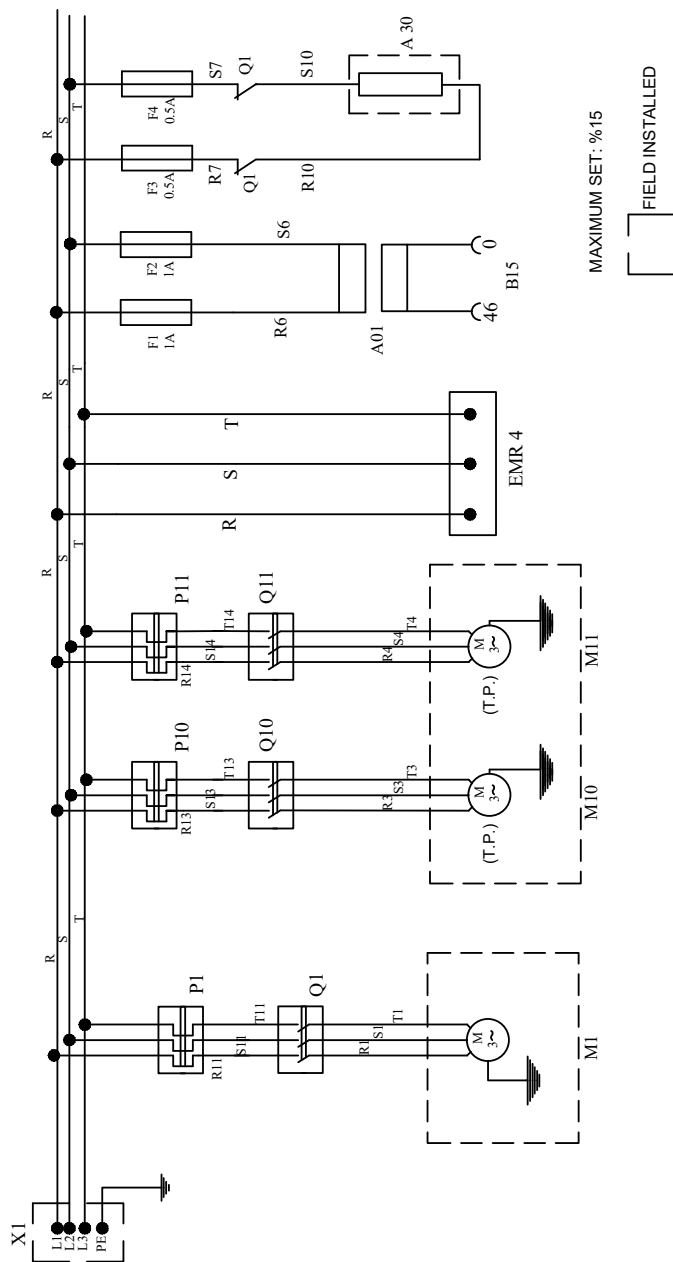

8. PDRCF / EDRCF

ID DIAGRAM DRAWINGS & GENERAL ARRANGEMENTS

6.3 ID DIAGRAM DRAWINGS PDRCF1150029 / EDRCF1150030

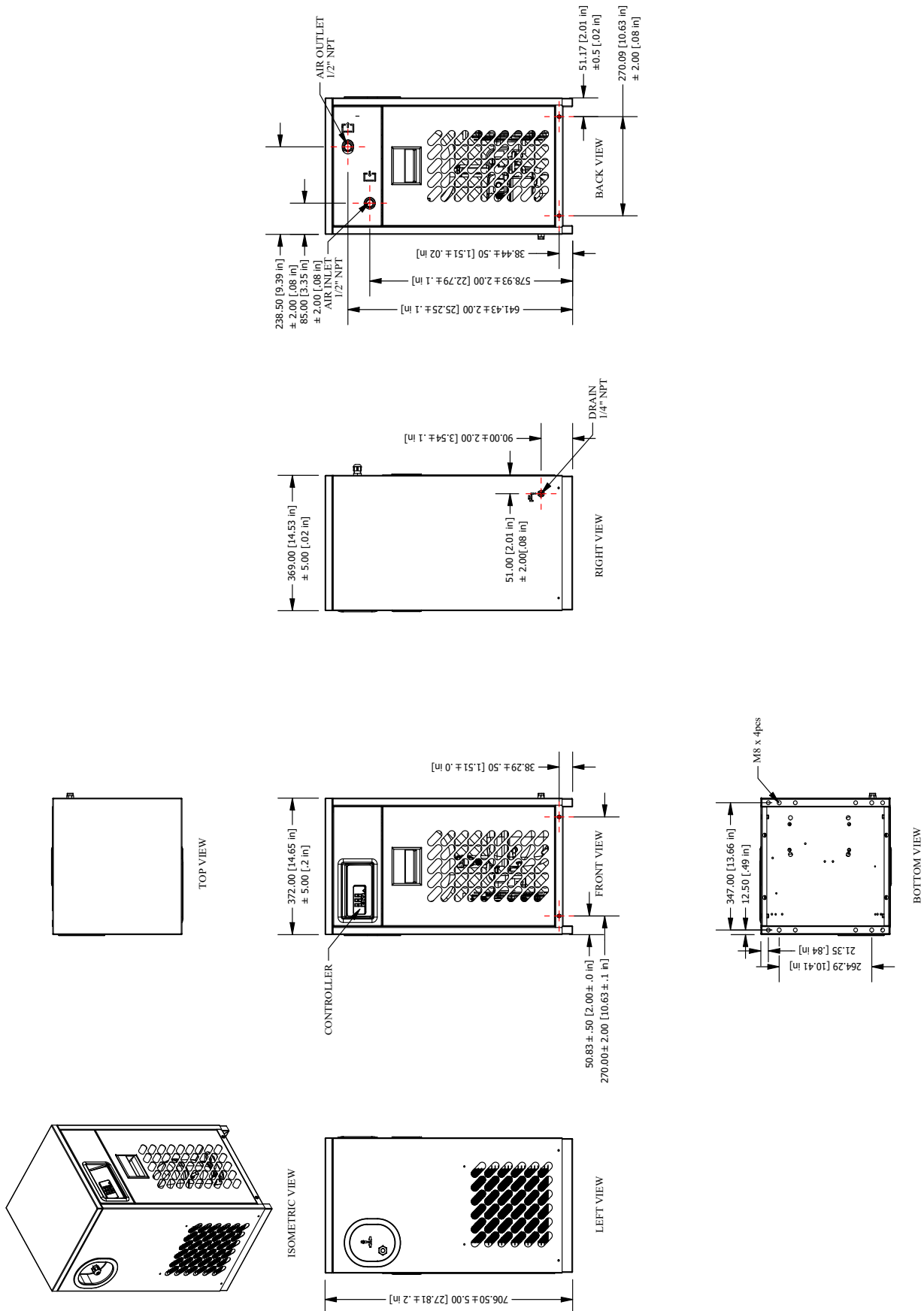

6.3 ID DIAGRAM DRAWINGS PDRCF1150058 / EDRCF1150058

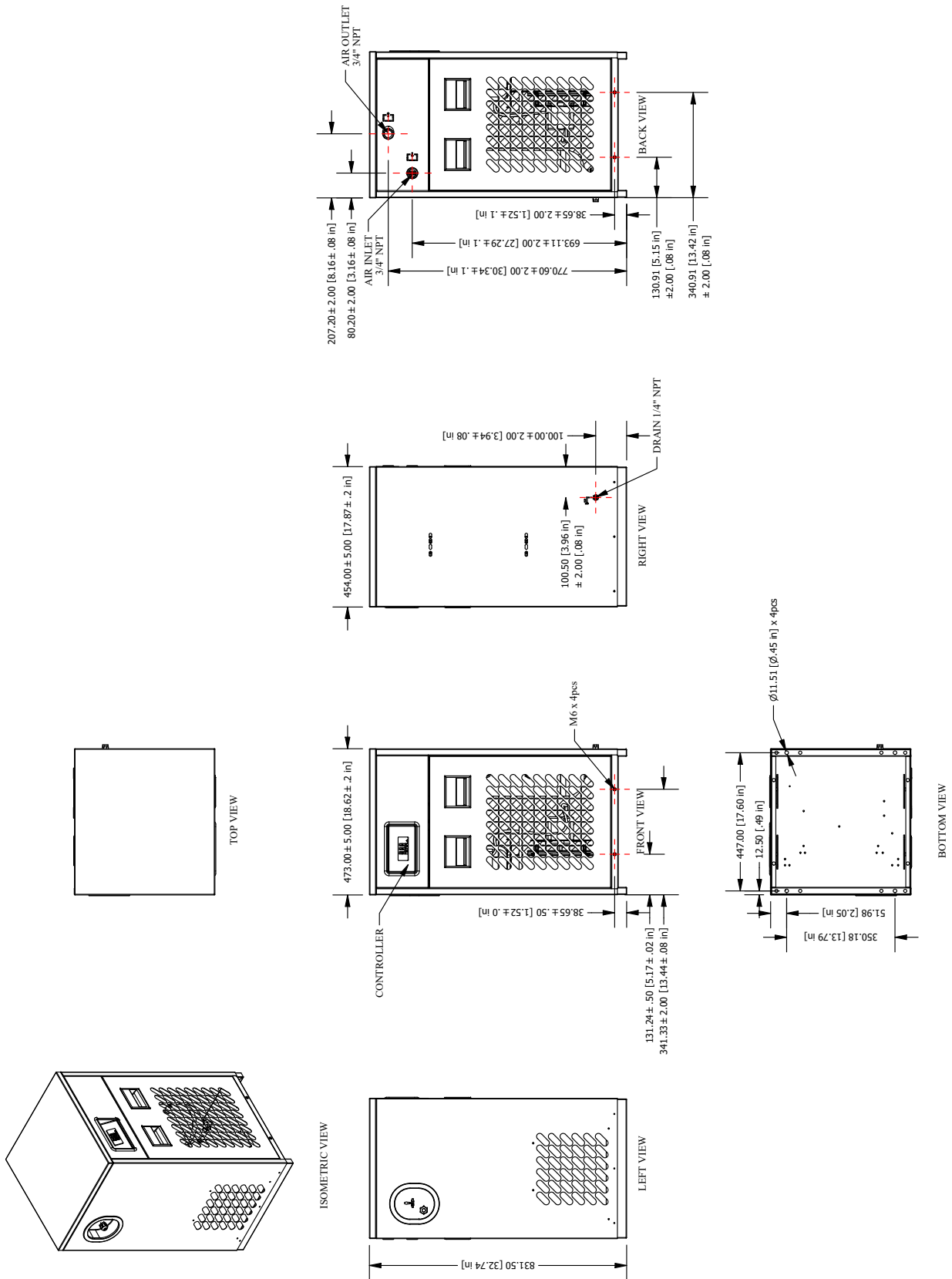

6.3 ID DIAGRAM DRAWINGS PDRCF1150115 / EDRCF1150115

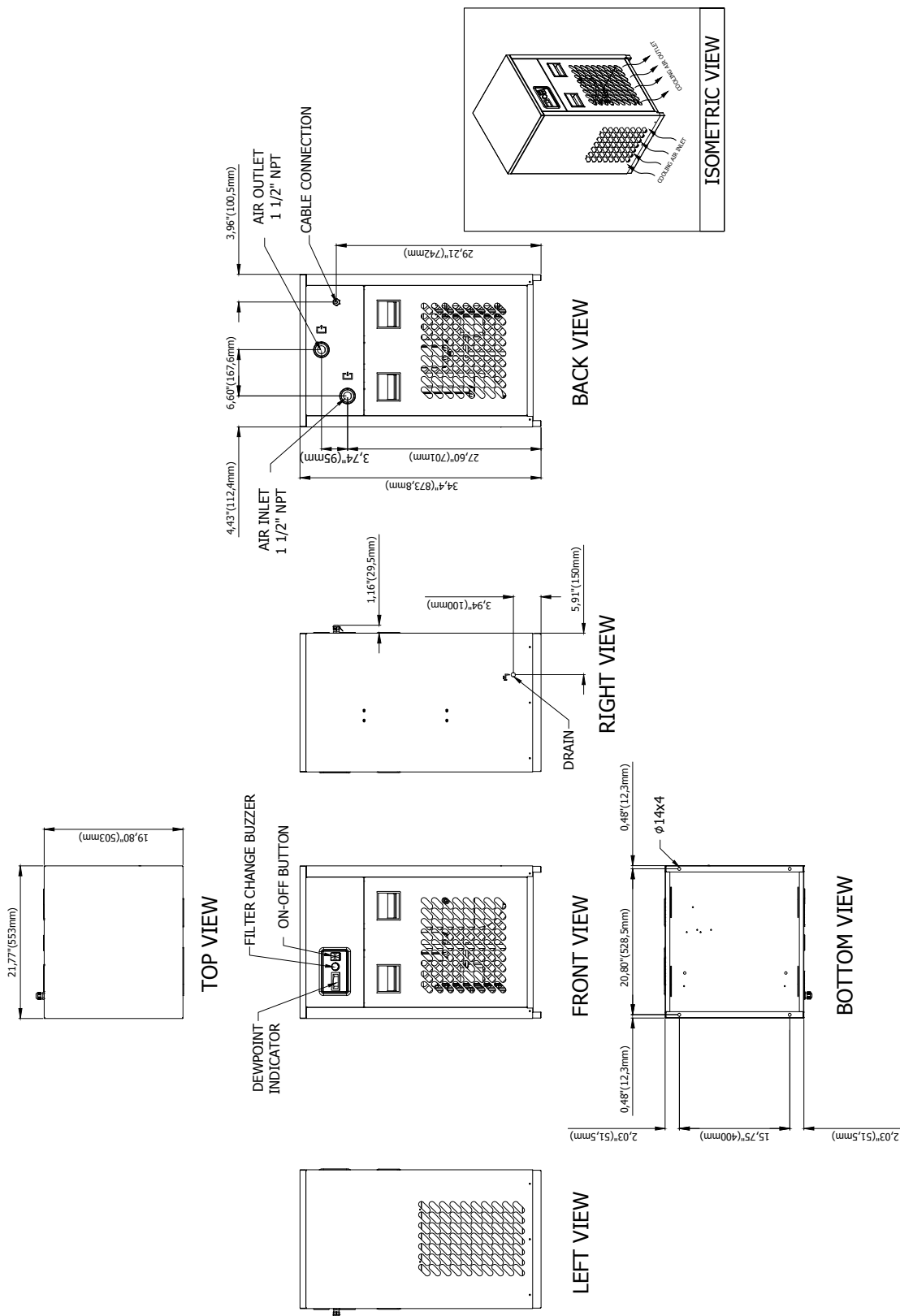

6.3 ID DIAGRAM DRAWINGS PDRCF1150144 / EDRCF1150144

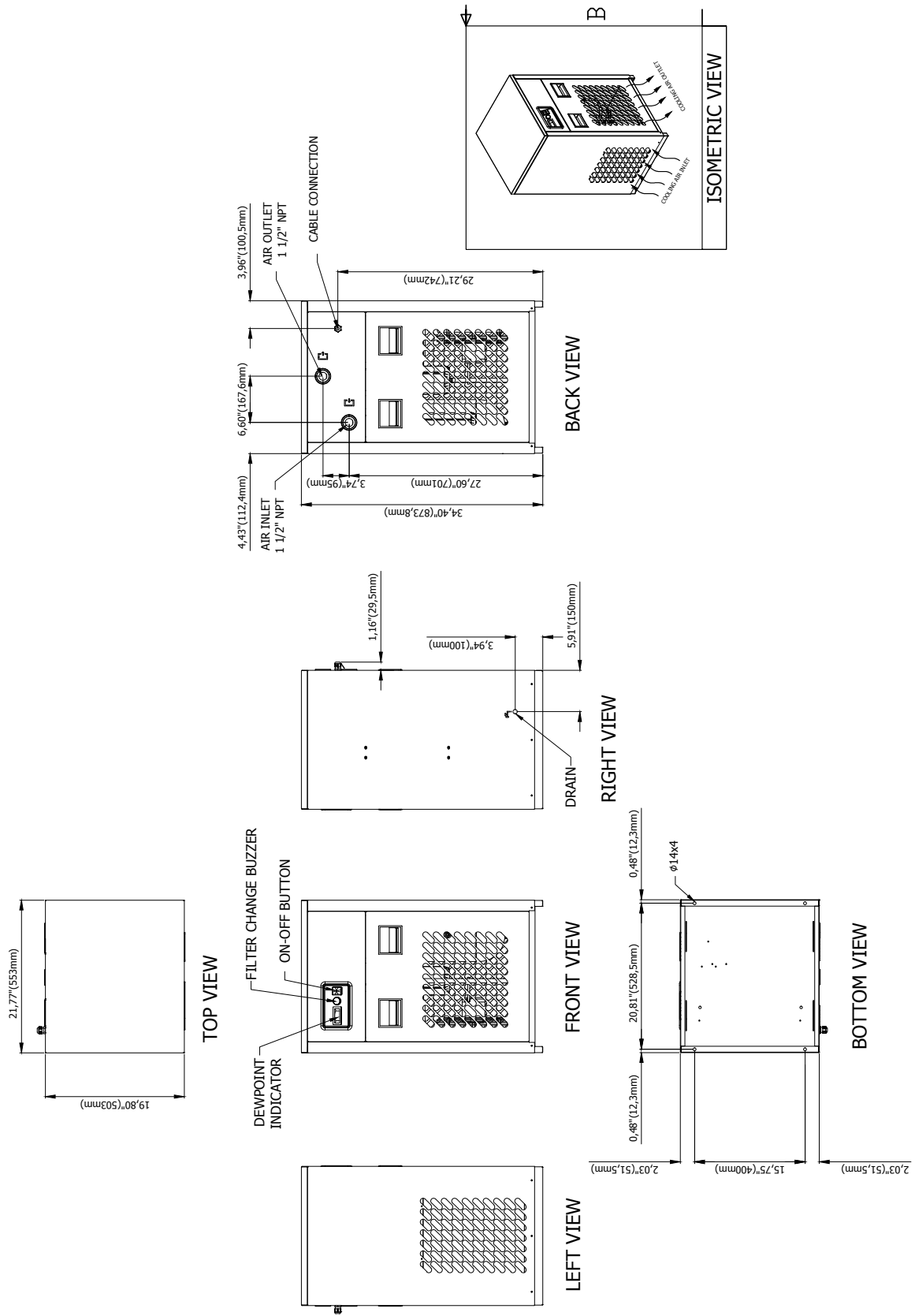

6.3 ID DIAGRAM DRAWINGS PDRCF2300288 / EDRCF2300288 (230 V)

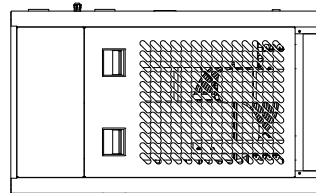
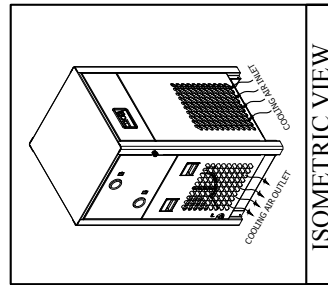

BACK VIEW

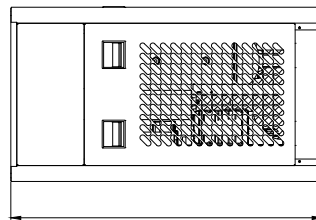

RIGHT VIEW

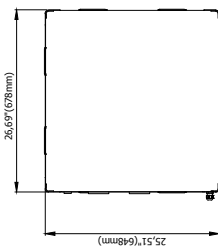

TOP VIEW

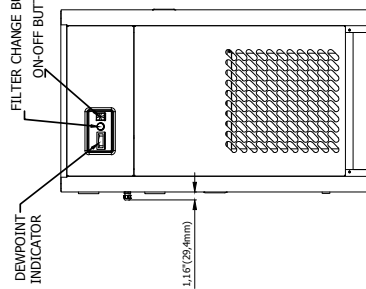

FRONT VIEW

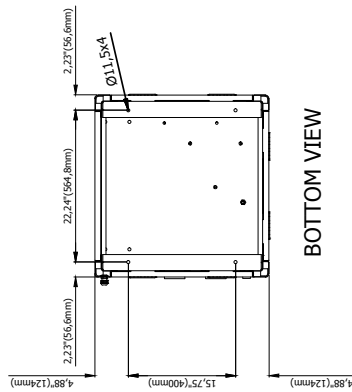

BOTTOM VIEW

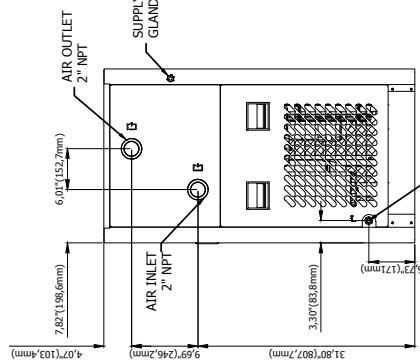

LEFT VIEW

6.3 ID DIAGRAM DRAWINGS PDRCF4600288 / EDRCF4600288 (460 V)

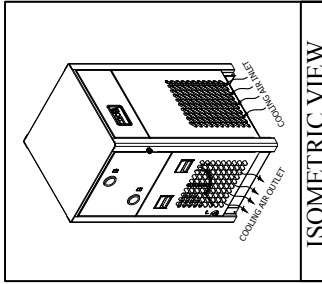

ISOMETRIC VIEW

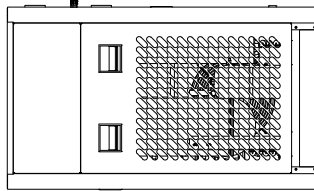

BACK VIEW

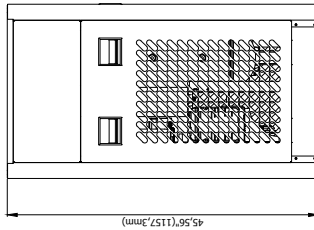

RIGHT VIEW

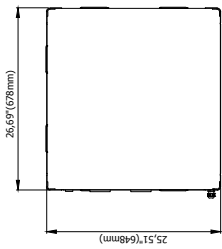

TOP VIEW

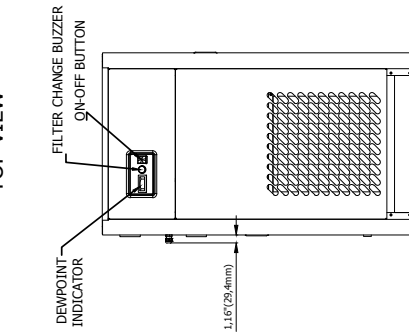

FRONT VIEW

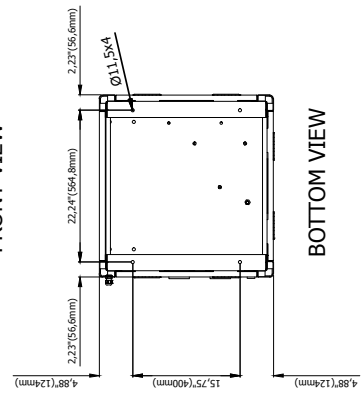

BOTTOM VIEW

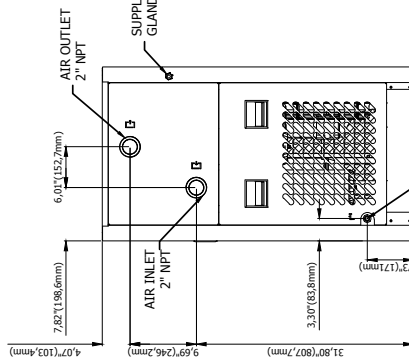

LEFT VIEW

6.3 ID DIAGRAM DRAWINGS PDRCF2300575 / EDRCF2300575 (230 V)

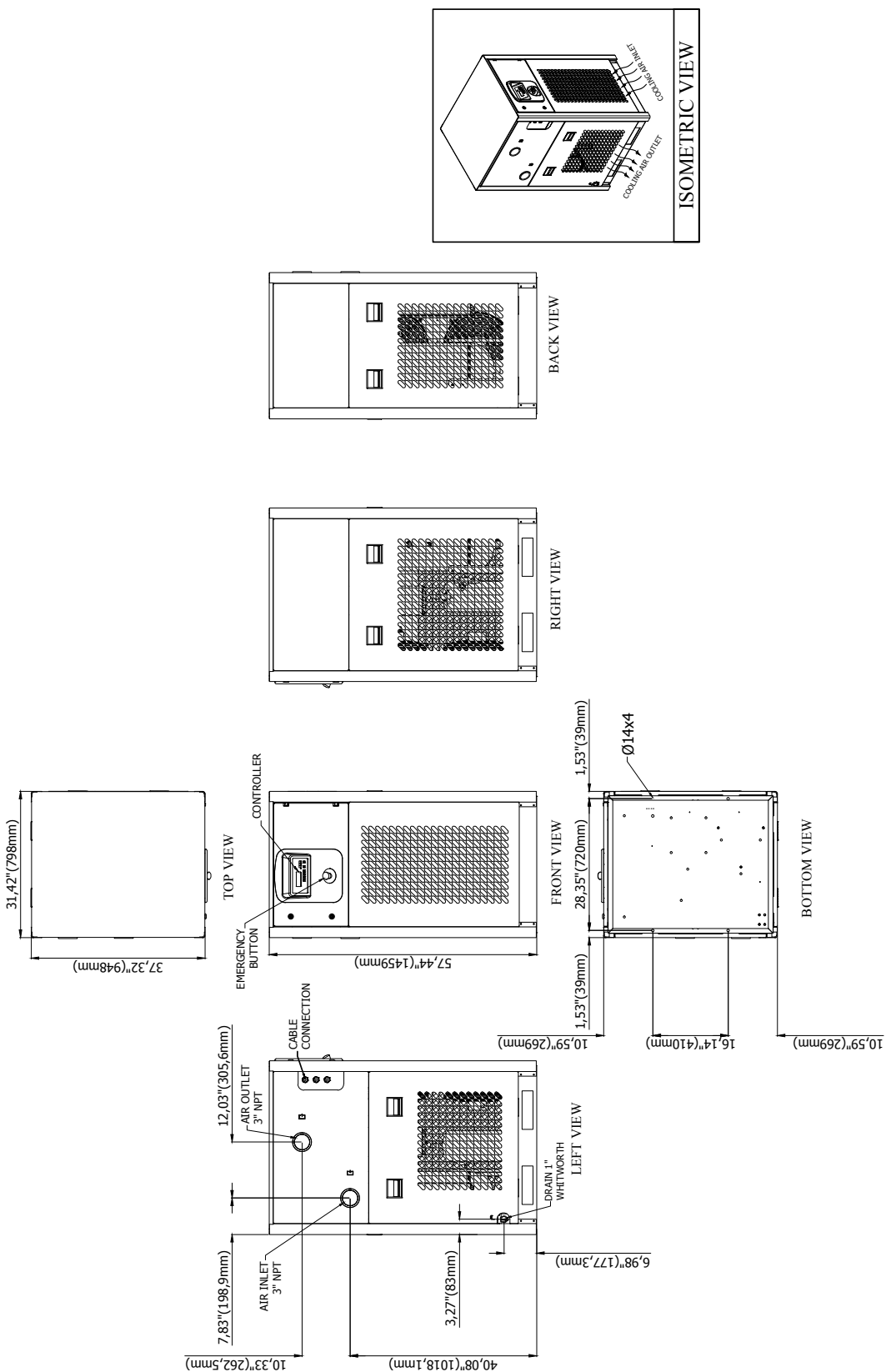

6.3 ID DIAGRAM DRAWINGS PDRCF4600575 / EDRCF4600575 (460 V)

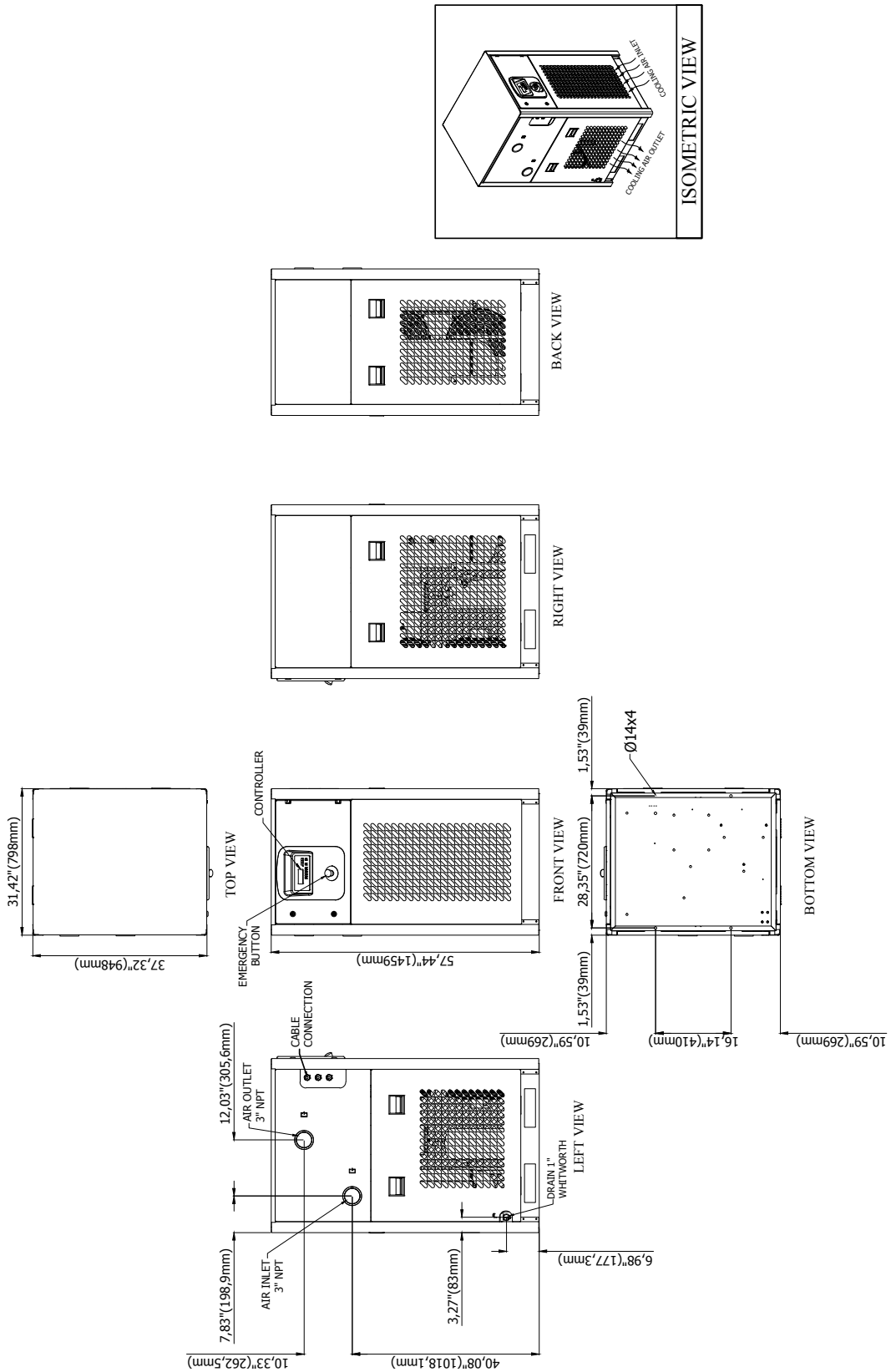

6.3 ID DIAGRAM DRAWINGS PDRCF4600850 / EDRCF4600850

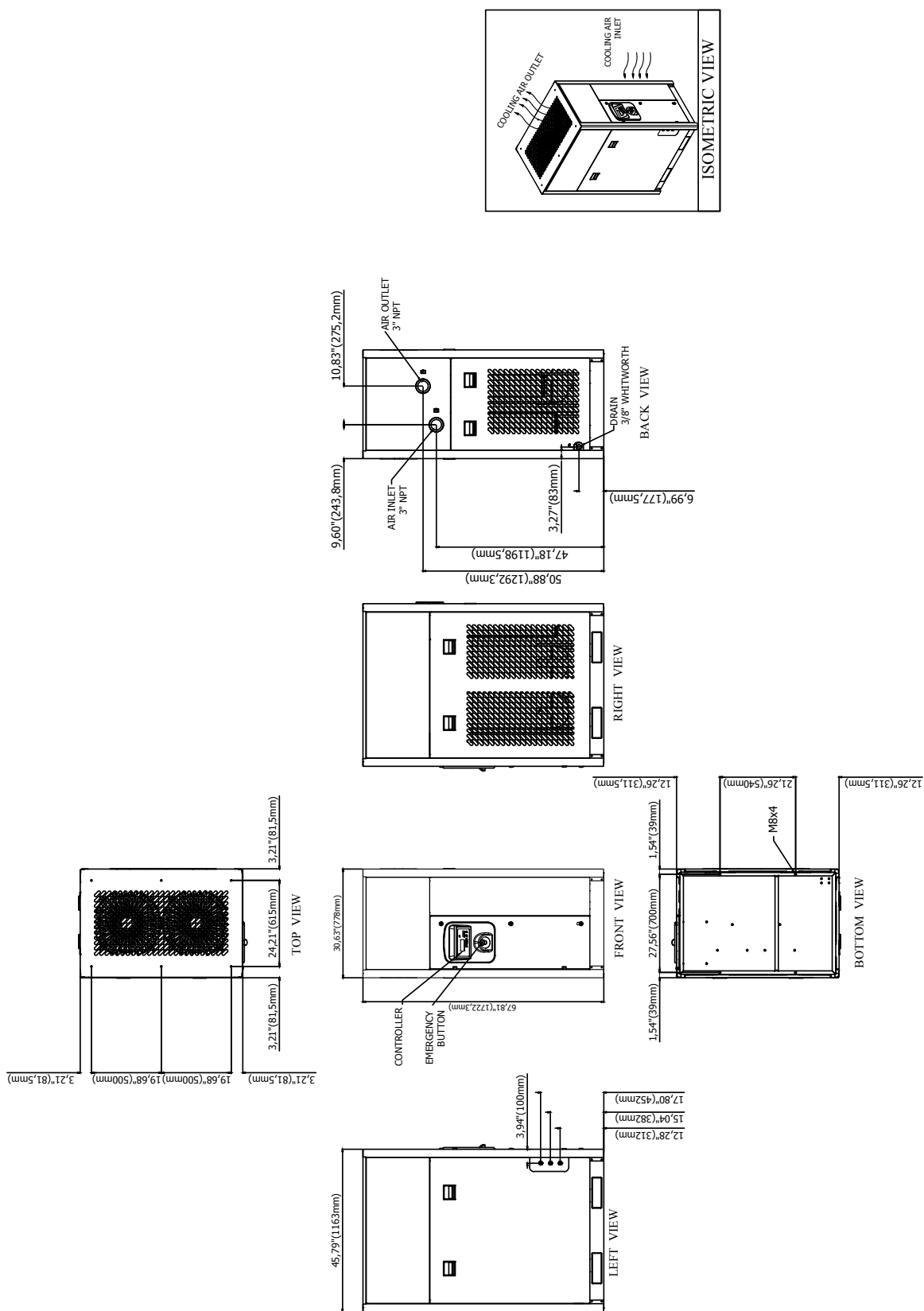

6.3 ID DIAGRAM DRAWINGS PDRCF4601200 / EDRCF4601200

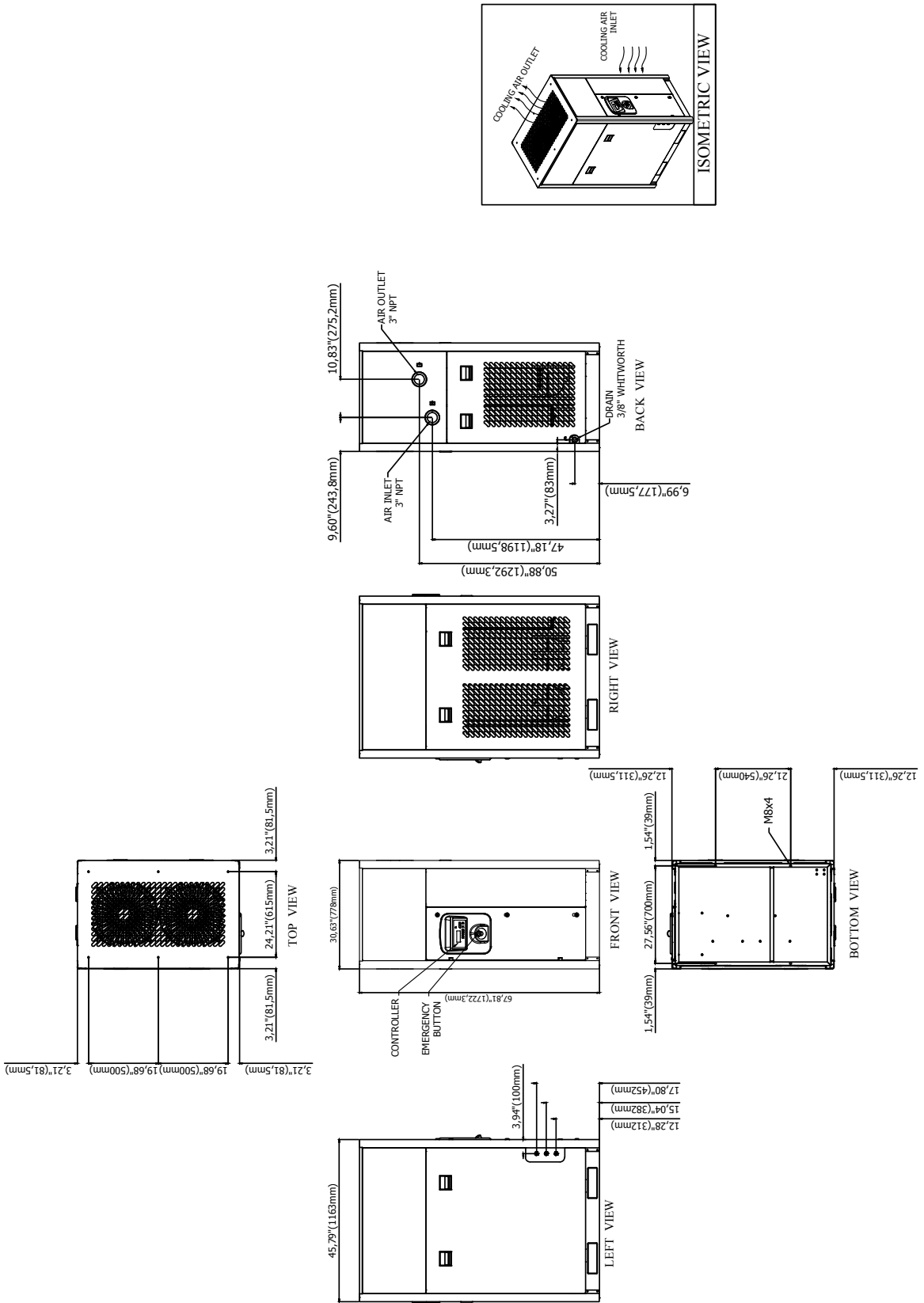

6.3 ID DIAGRAM DRAWINGS PDRCF4601600 / EDRCF4601600

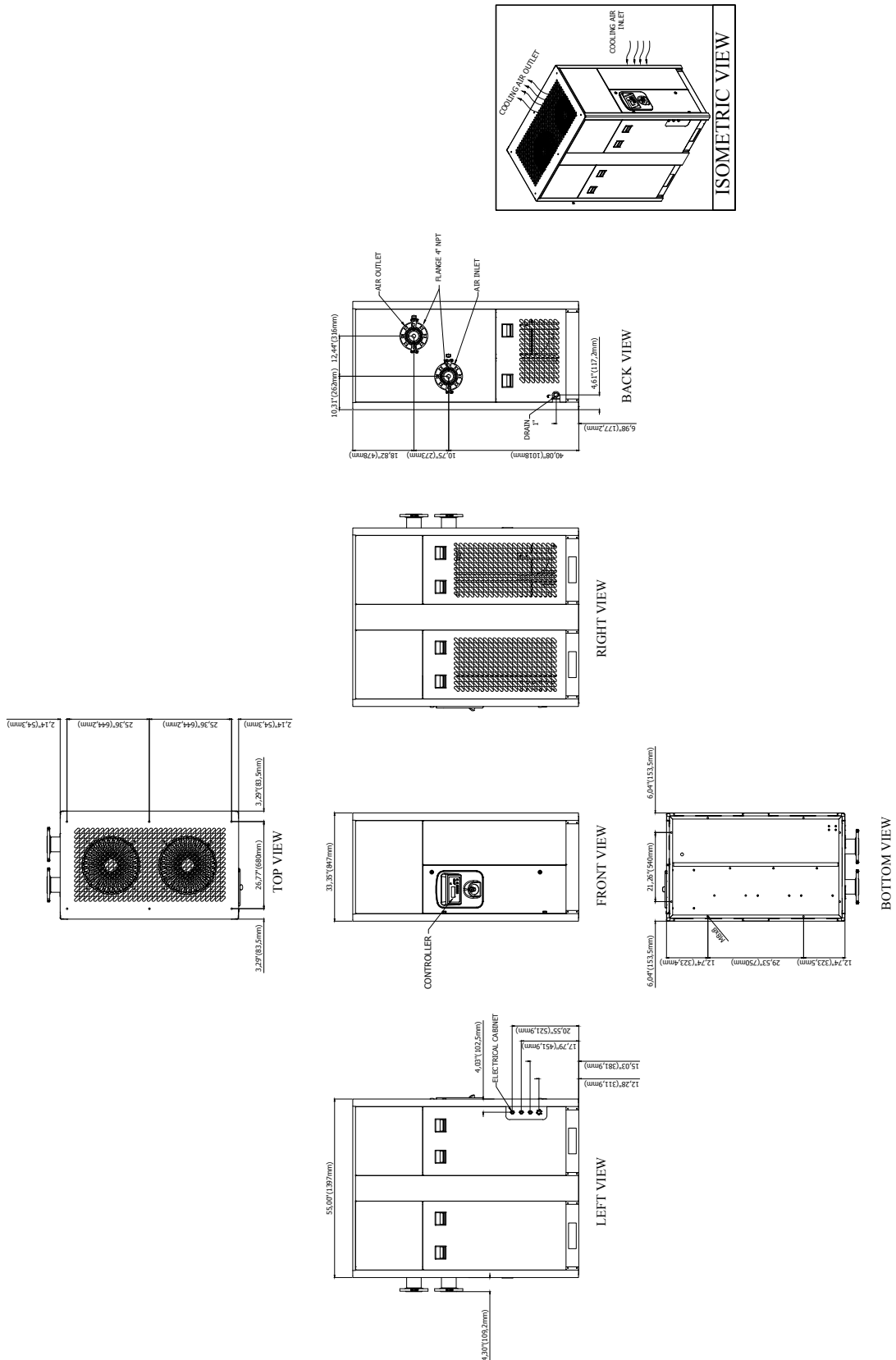

6.3 ID DIAGRAM DRAWINGS PDRCF4602000 / EDRCF4602000

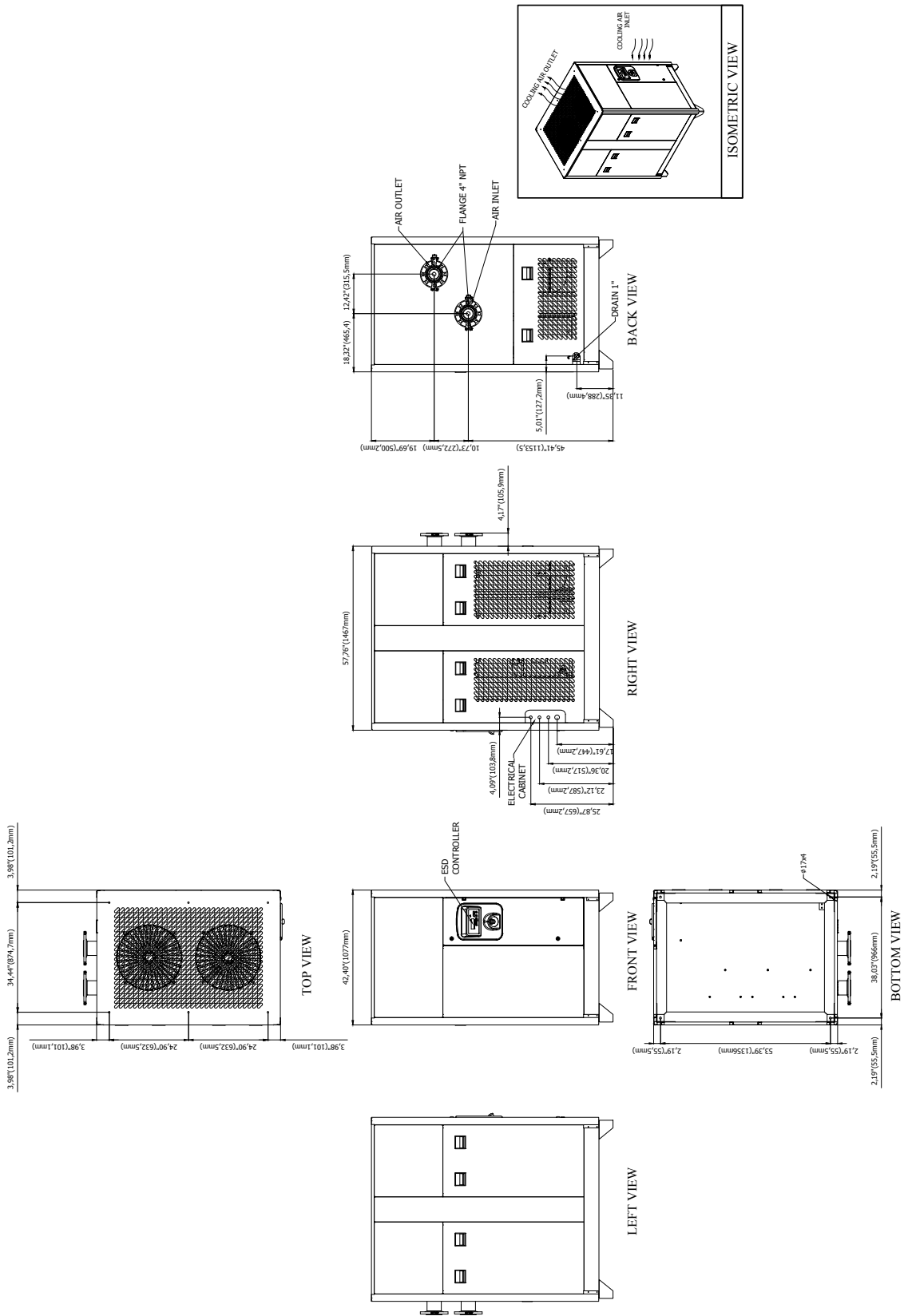

7.GENERAL ARRANGEMENTS

Model	Model	Element Type	Length (inch)	Width (inch)	Height (inch)	Weight (lbs)
PDRCF1150029	EDRCF1150030	FILTERKIT011B	14,53	14,65	27,81	77,16
PDRCF1150058	EDRCF1150058	FILTERKIT012A	17,87	18,62	32,74	116,60
PDRCF1150115	EDRCF1150115	FILTERKIT013	19,84	21,81	34,41	171,60
PDRCF1150144	EDRCF1150144	FILTERKIT013	19,84	21,81	34,41	182,60
PDRCF2300288	EDRCF2300288	FILTERKIT014	25,51	26,69	45,55	363,00
PDRCF2300575	EDRCF2300575	FILTERKIT015	37,32	31,42	57,48	594,00
PDRCF4600850	EDRCF4600850	FILTERKIT016	45,79	30,63	67,91	862,40
PDRCF4601200	EDRCF4601200	FILTERKIT016	45,79	30,63	67,91	902,00
PDRCF4601600	EDRCF4601600	Not Included	55,00	33,35	69,69	1.144,00
PDRCF4602000	EDRCF4602000	Not Included	57,76	42,40	75,98	1.531,20

ALL MODELS	Superheat of thermostatic expansion valve	Evaporating pressure	Fan pressure switch	Security high pressure switch	Security low pressure switch	Drain timer	Refrigerant temperature switch	Water flow valve (if water condenser)
	41.0 °F -50.0 °F	29.7 psi	130.5 - 174 psi	162,5 psi	23.2 psi	5 min. -5sec.	113 °F	159.5 psi

8. PDRCF / EDRCF EXPLODED DIAGRAMS & SPARE PART LISTS

8.1 - ED & Spare Part List

PDRCF1150029 / EDRCF1150030 (1P)

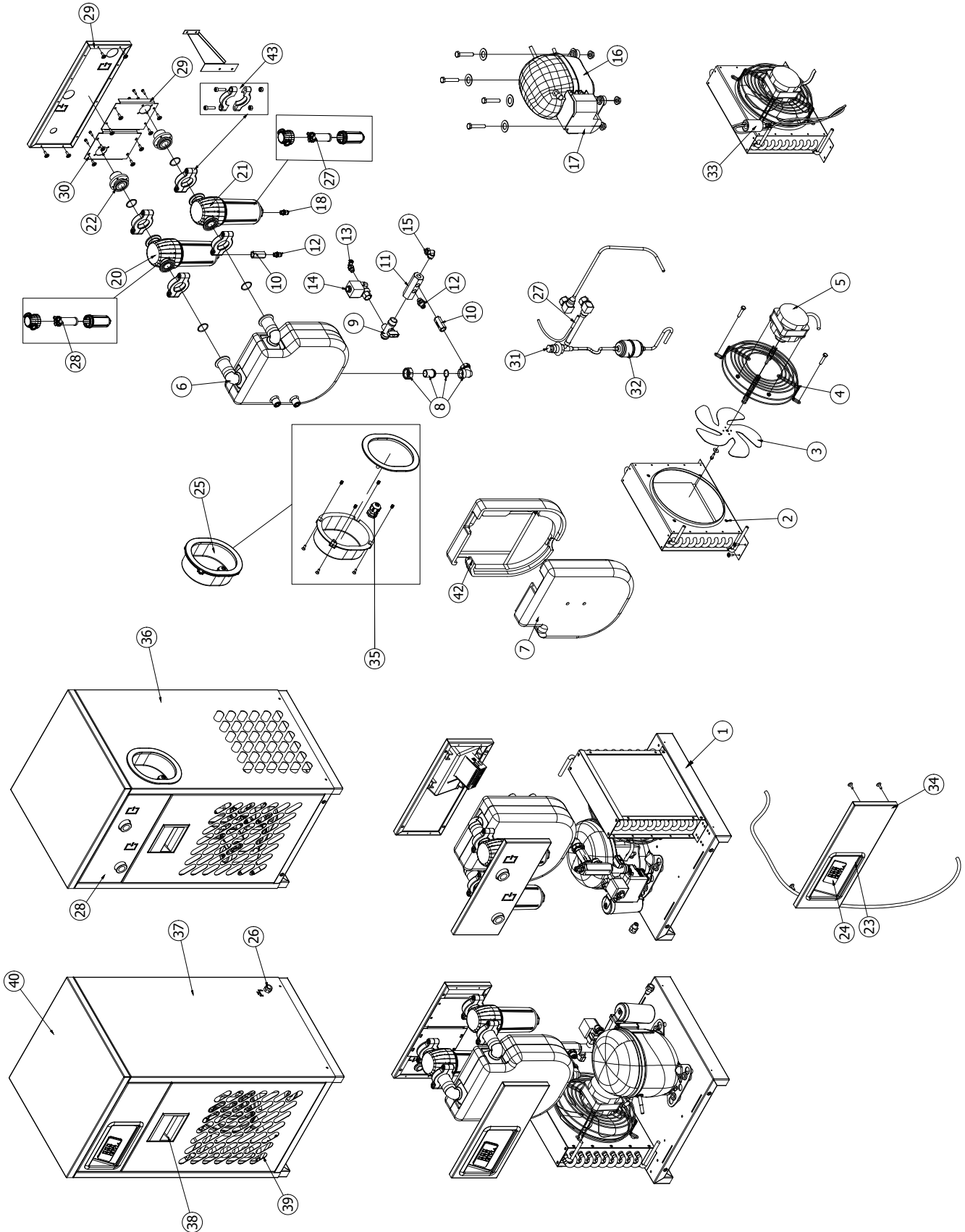

8.1 - ED & Spare Part List
PDRCF1150029 / EDRCF1150030 (1P)

43	1019759	G25-100 CLAMP KIT	4
42	1442270100	MK10-35 ISOLATION POLYSTYRENE TOP	1
41	1612250731	1/4"-4MM STRAIGHT FEMALE FITTINGS	1
40	1612264166	MK10-20-30-35-08-GON (7012 THICK RAGGED GREY)	1
39	1612264165	MK10-20-30-35-07-GON (7012 THICK RAGGED GREY)	2
38	1039220100	AIR DRYER HANDLE	2
37	1612264162	MK10-20-30-35-03-GON (7012 THICK RAGGED GREY)	1
36	1612285206	MK10-20-30-35-09-KTK (7012 THICK RAGGED GREY)	1
35	1023220100	POLYAMIDE CABLE UNION PG11	1
34	1612264164	MK10-20-30-35-06-GON (7012 THICK RAGGED GREY)	1
33	1026750100	12-9 BAR-FAN SWITCH	1
32	1026100100	MK10-90 FILTER DRYER	1
31	1025980100	MK10-60 EXPANSION VALVE	1
30	1612264149	MK10-20-30-35-05A-GON (GALVANIZED)	1
29	1612264150	MK10-20-30-35-05B-GON (GALVANIZED)	1
28	1612285232	MK10-20-30-35-10-KTK (7012 THICK RAGGED GREY)	1
27	1057380100	NTC SENSOR	1
26	1026290100	PASS UNION Ø6mm	1
25	1612273697	MK10-110 CABLE COLLECTION BOX	1
24	1057740100	DPR0 CONTROLLER 30A 115V	1
23	1057340100	DRYER FRONT PANEL	1
22	103885100	MK10-20-30 CONNECTION KIT NPT	2
21	1035799	ME-MKON-0065-3565/0123-Y-BM-PK	1
20	1035800	ME-MKON-0065-3565/0123-X-BM-PK	1
19	1035794	GKON-65-1/2-MY-A/1/4-NSG-W-0000	1
18	1035793	GKON-65-1/2-MX-A/1/4-NSG-W-0000	1
17	1062880100	MK10-20 COMPRESSOR 115/1/60 ELECTRIC BOX	1
16	1023900100	MK10-20 COMPRESSOR 115/1/60	1
15	1612250732	1/4"-4MM UNION - ELBOW	1
14	1026380100	MK10-80 115V 16Bar SOLENOID VALVE	1
13	1029740100	1/4"-6*8 METAL SWIVELLING ELBOW UNION	1
12	1034620100	1/4"-Ø6 STRAIGHT FEMALE FITTINGS	3
11	1022290100	MK10-150 COLLECTOR	1
10	1002090100	1/4" CHECK VALVE	2
9	1018430100	1/2"-1/4" FILTERED DRAIN	1
8	1002060100	1/2" CORNER UNION	1
7	1442260100	MK10-35 ISOLATION POLYSTYRENE LOWER	1
6	1017260100	MK10-35 EXCHANGER	1
5	1025120100	MK10-40 115V UL FAN MOTOR	1
4	1025260100	MK10-40 (Ø220) FAN GRILL	1
3	1025150100	MK10-40 (Ø200) FAN PROPELLER	1
2	1025060100	MK35 CONDENSER	1
1	1612264160	MK10-20-30-35-01-GON (7012 THICK RAGGED GREY)	1
ITEM NO.	PART NO.	DESCRIPTION	QTY

PART LIST

31	EXPANSION VALVE	MK10-60 EXPANSION VALVE	1025410100
24	CONTROLLER	DPR0 CONTROLLER 30A 230V	1057350100
14	SOLENOID VALVE	MK10-130 230V 16BAR SOL. VALVE	1018440100
16	COMPRESSOR	MK10-20 COMP. 220-230/1/50-60	1024550100
5	FAN MOTOR	MK10-40 230/1/60 UL FAN MOTOR	1025290100

8.1 - ED & Spare Part List

PDRCF1150058 / EDRCF1150058 (1P)

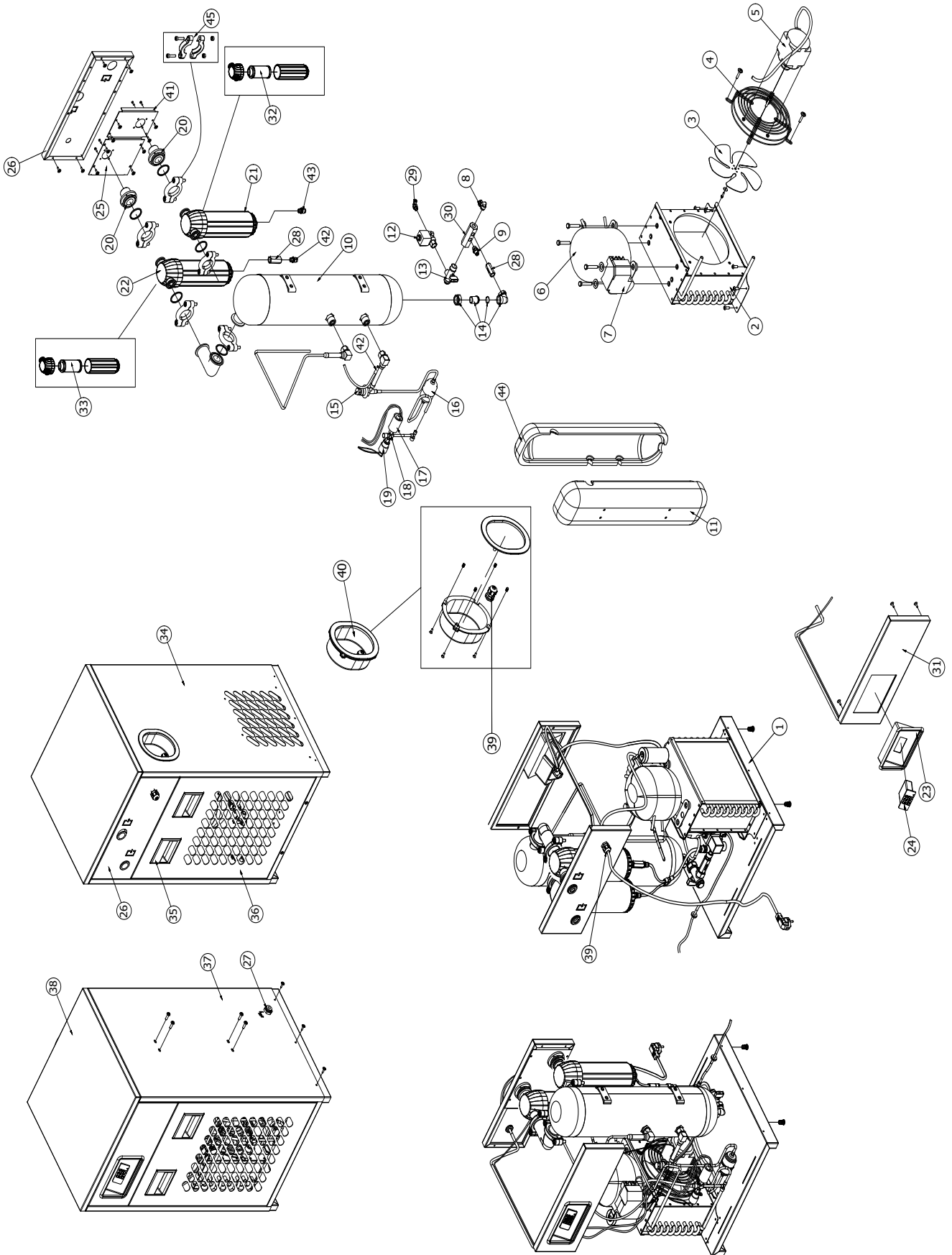

8.1 - ED & Spare Part List
PDRCF1150058 / EDRCF1150058 (1P)

45	1019819	G150-250 CLAMP KIT	5
44	1442350100	MK40-60 ISOLATION POLYSTYRENE TOP	1
43	1612250731	1/4"-4MM STRAIGHT FEMALE FITTINGS	1
42	1057380100	NTC SENSOR	1
41	1000670700	MK40-50-60-05B PANEL (GALVANIZED)	1
40	1612273697	MK10-110 CABLE COLLECTION BOX	1
39	1023220100	POLYAMIDE CABLE UNION PG11	1
38	1047510100	MK40-50-60-08 PANEL (7012 THICK RAGGED GREY)	1
37	1043740100	MK40-50-60-02 PANEL (7012 THICK RAGGED GREY)	1
36	1037460100	MK40-50-60-07 PANEL (7012 THICK RAGGED GREY)	2
35	1039220100	AIR DRYER HANDLE	4
34	1038260100	MK50-60-03B PANEL (7012 THICK RAGGED GREY)	1
33	1012807	ME-MKON-0155-180300/0170-Y-BM-PK	1
32	1012808	ME-MKON-0155-180300/0170-X-BM-PK	1
31	1042000100	MK40-50-60-06 PANEL (7012 THICK RAGGED GREY)	1
30	1022290100	MK10-150 COLLECTOR	1
29	1029740100	1/4"-6*8 METAL SWIVELLING ELBOW UNION	1
28	1002090100	1/4" CHECK VALVE	2
27	1062260100	1/4" - Ø6 TRANSITION NIPPLE (NPT)	1
26	1040160100	MK40-50-60-04 PANEL (7012 THICK RAGGED GREY)	1
25	1000670600	MK40-50-60-05A PANEL (GALVANIZED)	1
24	1057740100	DPR0 CONTROLLER 30A 115V	1
23	1057340100	DRYER FRONT PANEL	1
22	1012805	GKON-155-3/4-MY-A1/4-NSG-W-0000	1
21	1012806	GKON-155-3/4-MX-A1/4-NSG-W-0000	1
20	1060570100	MK40-50-60 CONNECTION KIT NPT	2
19	1026770100	25 BAR HIGH PRESSURE SWITCH	1
18	1029510100	3 SIDE SCHRADER, 1 SIDE WELDED T	1
17	1026750100	12-9 BAR-FAN SWITCH	1
16	1026100100	MK10-90 FILTER DRYER	1
15	1025980100	MK10-60 EXPANSION VALVE TYPE-1	1
14	1002060100	1/2" CORNER UNION	1
13	1018430100	1/2"-1/4" FILTERED DRAIN	1
12	1026380100	MK10-80 115V 16Bar SOLENOID VALVE	1
11	1442340100	MK40-60 ISOLATION POLYSTYRENE LOWER	1
10	1045560100	MK40-50-60 HEAT EXCHANGER-MKR	1
9	1026430100	1/4" 6mm STRAIGHT FEMALE FITTINGS	3
8	1612250732	1/4"-4 UNION - ELBOW	1
7	1062890100	MK50 COMPRESSOR 115/1-60 ELECTRIC BOX	1
6	1024470100	MK50 COMPRESSOR 115/1/60	1
5	1025130100	MK50-80 115V UL FAN MOTOR	1
4	1025270100	MK50-70 (Ø275) FAN GRILL	1
3	1025160100	MK50-70 (Ø254) FAN PROPELLER	1
2	1024990100	MK50-60 CONDENSER	1
1	1038050100	MK40-50-60-01 PANEL (7012 THICK RAGGED GREY)	1
ITEM NO.	PART NO.	DESCRIPTION	QTY
PART LIST			

24	CONTROLLER	DPR0 CONTROLLER 30A 230V	1057350100
12	SOLENOID VALVE	MK10-130 230V 16BAR SOL. VALVE	1018440100
6	COMPRESSOR	MK50 COMP. 220-230/1/50-60	1024420100
5	FAN MOTOR	MK50-60 230/1/60 UL FAN MOTOR	1025110100

8.1 - ED & Spare Part List

PDRCF1150115 / EDRCF1150115 (1P)

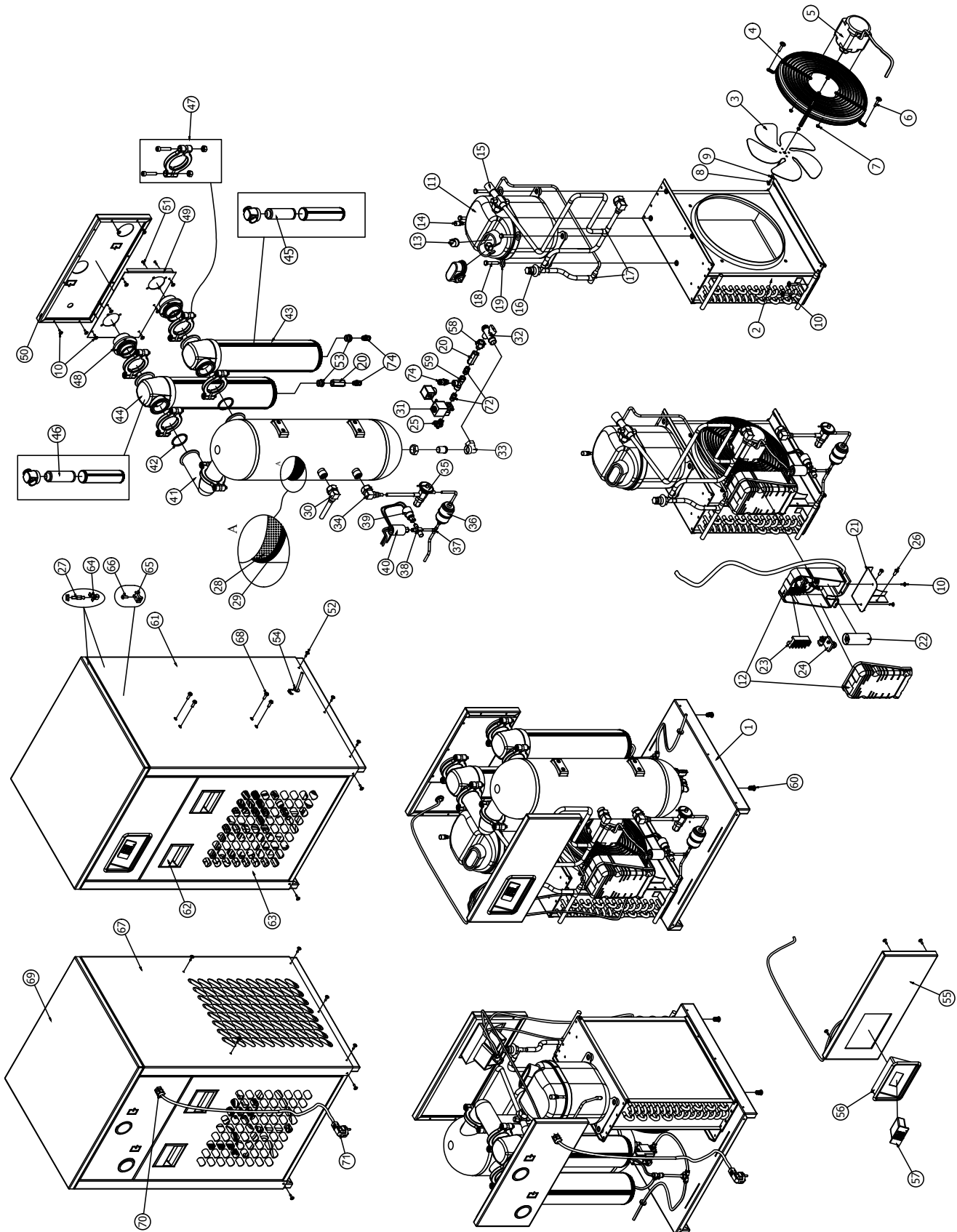

8.1 - ED & Spare Part List
PDRCF1150115 / EDRCF1150115 (1P)

PART LIST					
DWG SIZE	ITEM NO.	PART NO.	DESCRIPTION	REV	QTY
	1	MK90E-CAB	CABINET BASE		1
	2	MK70E-CON	CONDANSER		1
	3	M-FAN-0150	FAN BLADE		1
	4	M-GRL-0150	FAN GRILL		1
	5	M-FMT-0150-115-1-60	FAN MOTOR		1
	6	MK260E-BLT630	BOLT M6x30		4
	7	MK110E-NT4	NUT M4		4
	8	MK110E-BLT414	BOLT M4x14mm		1
	9	MK110E-WHR20	WASHER Ø20xØ4,3x1,5		1
	10	MK90E-BLT412	BOLT M4x12		30
	11	M-CMP-0100-115-1-60	COMPRESSOR		1
	12	M-CEB-0100-115-1-60	COMPRESSOR ELECTRICAL BOX		1
	13	M-COP-0100-115-1-60	COMPRESSOR OVERLOAD PROTECTOR		1
	14	MK260E-STC	SETTING THE CONNECTION		1
	15	MK130E-RTA1	ROTOLOCK ADAPTOR1		1
	16	M-BYV-0100	BY-PASS VALVE		1
	17	MK90E-CPT1	CUPPER T1		2
	18	MK150E-BLT840	BOLT M8x40		4
	19	MK260E-WHR22	WASHER Ø22xØ8,5x2,5		4
	20	MK170E-CHV	CHECK VALVE		2
	21	MK90E-ELBS	ELECTRICAL BOX LOWER SUPPORT PLATE		1
	22	M-CSC-0100-115-1-60	COMPRESSOR START CAPACITOR		1
	23	MK110E-TRM	THERMINAL BLOCK		1
	24	M-CSR-0100-115-1-60	COMPRESSOR START RELAY		1
	25	MK170E-EWF	90° 1 / 4" - 6mm ELBOW		1
	26	MK90E-RVT4	RIVET Ø4		2
	27	M-STU-6000	CABINET STUD AND NUT		8
	28	MK90E-EXC	HEAT EXCHANGER		1
	29	MK90E-IHE	INSULATION OF HEAT EXCHANGER		1
	30	MK110E-RTA2	ROTOLOCK ADAPTOR2		1
	31	M-SLV-0150-115	SOLENOID VALVE		1
	32	M-DBV-0200	DRAIN BALL VALVE		1
	33	MK260E-ELW2	ELBOW 2		1
	34	MK70E-RTA3	ROTOLOCK ADAPTOR3		1
	35	MK70E-EXV	EXPANSION VALVE		1
	36	M-DRI-0200	DRYER-DEHYDRATOR		1
	37	MK90E-CPT2	CUPPER T2		1
	38	MK90E-TDP	ADAPTOR T		1
	39	M-HPS-0200	HIGH PRESSURE SWITCH		1
	40	M-FNS-0200	FAN ON/OFF SWITCH		1
	41	MK90E-CNK1	CONNECTION CIT1		1
	42	MK90E-ORG	ORING		5
	43	MK90E-ELK-X	COMPRESSED AIR FILTER KIT (X)		1
	44	MK90E-ELK-Y	COMPRESSED AIR FILTER KIT (Y)		1
	45	MK90E-FIE-X	COMPRESSED AIR FILTER ELEMENT (X)		1
	46	MK90E-FIE-Y	COMPRESSED AIR FILTER ELEMENT (Y)		1
	47	MK90E-CPG	COUPLING CLAMP		5
	48	MK90E-CNK2-NPT	CONNECTION CIT2		2
	49	MK90E-CAI	CABINET INSIDE		1
	50	MK90E-CRT	CABINET REAR TOP		1
	51	MK90E-BLT610	BOLT M6x10		8
	52	N/A	N/A		-
	53	MK260E-RDC	REDUCTION 1 / 2" - 1 / 4"		2
	54	MK90E-GFD	GASKET FOR DRAIN		1
	55	MK90E-COP	CONTROLLER PANEL		1
	56	MK260E-PCP	PLASTIC CONTROL PANEL		1
	57	MK130E-DPI-115	DIGITAL CONTROLLER		1
	58	MK150E-RDC	REDUCTION 3/8" - 1/4"		1
	59	MK170E-T1/4	1 / 4" T CONNECTOR		1
	60	MK260E-RNT8	RIVET NUT M8		4
	61	MK90E-CBR	CABINET RIGHT		1
	62	M-CHN-6000	CABINET HANDLE (NEW)		4
	63	MK90E-CSG	CABINET STRIPPING		2
	64	M-FAS-6000	CABINET FASTENER		8
	65	MK90E-CSP	CABLE STRAP		6
	66	MK90E-RVT3,5	RIVET Ø3,5		6
	67	MK90E-CLT	CABINET LEFT		1
	68	MK90E-BLT615	BOLT M6x15		4
	69	MK90E-CAT	CABINET TOP		1
	70	MK260E-CG11	CABLE GLAND PG11		1
	71	MK130E-PWC	POWER CABLE		1
	72	MK170E-NIP1/4	1 / 4" NIPPLE		2
	73	N/A	N/A		-
	74	MK150E-FIT6	1 / 4" - 6mm FITTINGS		3

8.1 - ED & Spare Part List

PDRCF1150144 / EDRCF1150144 (1P)

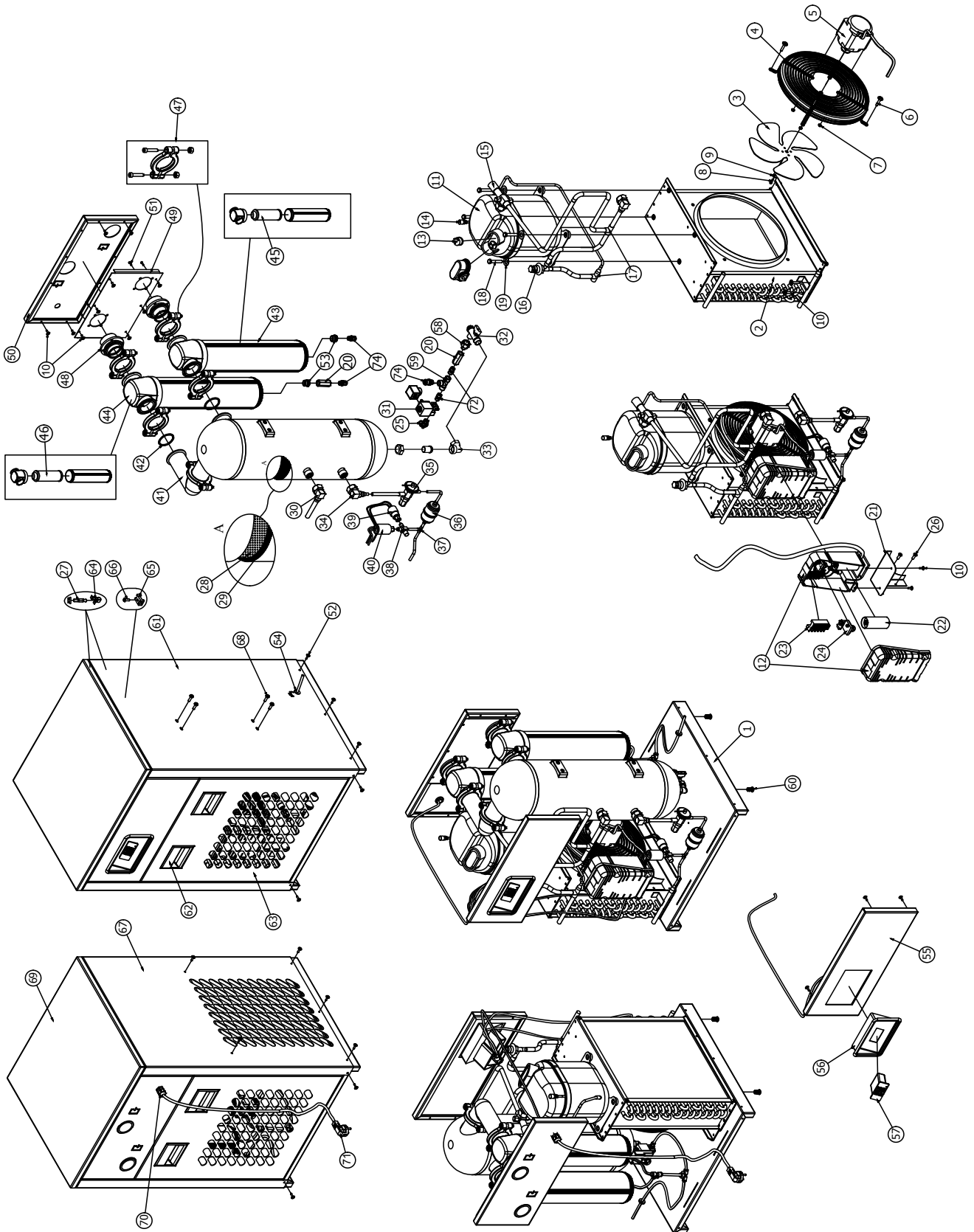

8.1 - ED & Spare Part List
PDRCF1150144 / EDRCF1150144 (1P)

PART LIST					
DWG SIZE	ITEM NO.	PART NO.	DESCRIPTION	REV	QTY
	1	MK90E-CAB	CABINET BASE		1
	2	MK90E-CON	CONDANSER		1
	3	M-FAN-0200	FAN BLADE		1
	4	M-GRL-0200	FAN GRILL		1
	5	M-FMT-0150-115-1-60	FAN MOTOR		1
	6	MK260E-BLT630	BOLT M6x30		4
	7	MK110E-NT4	NUT M4		4
	8	MK110E-BLT414	BOLT M4x14mm		1
	9	MK110E-WHR20	WASHER Ø20xØ4,3x1,5		1
	10	MK90E-BLT412	BOLT M4x12		30
	11	M-CMP-0150-115-1-60	COMPRESSOR		1
	12	M-CEB-0150-115-1-60	COMPRESSOR ELECTRICAL BOX		1
	13	M-COP-0150-115-1-60	COMPRESSOR OVERLOAD PROTECTOR		1
	14	MK260E-STC	SETTING THE CONNECTION		1
	15	MK130E-RTA1	ROTOLOCK ADAPTOR1		1
	16	M-BYV-0400	BY-PASS VALVE		1
	17	MK90E-CPT1	CUPPER T1		2
	18	MK150E-BLT840	BOLT M8x40		4
	19	MK260E-WHR22	WASHER Ø22xØ8,5x2,5		4
	20	MK170E-CHV	CHECK VALVE		2
	21	MK90E-ELBS	ELECTRICAL BOX LOWER SUPPORT PLATE		1
	22	M-CSC-0150-115-1-60	COMPRESSOR START CAPACITOR		1
	23	MK110E-TRM	THERMINAL BLOCK		1
	24	M-CSR-0150-115-1-60	COMPRESSOR START RELAY		1
	25	MK170E-EWF	90° 1 / 4" - 6mm ELBOW		1
	26	MK90E-RVT4	RIVET Ø4		2
	27	M-STU-6000	CABINET STUD AND NUT		8
	28	MK90E-EXC	HEAT EXCHANGER		1
	29	MK90E-IHE	INSULATION OF HEAT EXCHANGER		1
	30	MK110E-RTA2	ROTOLOCK ADAPTOR2		2
	31	M-SLV-0150-115	SOLENOID VALVE		1
	32	M-DBV-0200	DRAIN BALL VALVE		1
	33	MK260E-ELW2	ELBOW 2		1
	34	N/A	N/A		-
	35	M-EXV-0200	EXPANSION VALVE		1
	36	M-DRI-0200	DRYER-DEHYDRATOR		1
	37	MK90E-CPT2	CUPPER T2		1
	38	MK90E-TDP	ADAPTOR T		1
	39	M-HPS-0200	HIGH PRESSURE SWITCH		1
	40	M-FNS-0200	FAN ON/OFF SWITCH		1
	41	MK90E-CNK1	CONNECTION CIT1		1
	42	MK90E-ORG	ORING		5
	43	MK90E-ELK-X	COMPRESSED AIR FILTER KIT (X)		1
	44	MK90E-ELK-Y	COMPRESSED AIR FILTER KIT (Y)		1
	45	MK90E-FIE-X	COMPRESSED AIR FILTER ELEMENT (X)		1
	46	MK90E-FIE-Y	COMPRESSED AIR FILTER ELEMENT (Y)		1
	47	MK90E-CPG	COUPLING CLAMP		5
	48	MK90E-CNK2-NPT	CONNECTION CIT2		2
	49	MK90E-CAI	CABINET INSIDE		1
	50	MK90E-CRT	CABINET REAR TOP		1
	51	MK90E-BLT610	BOLT M6x10		8
	52	N/A	N/A		-
	53	MK260E-RDC	REDUCTION 1 / 2" - 1 / 4"		2
	54	MK90E-GFD	GASKET FOR DRAIN		1
	55	MK90E-COP	CONTROLLER PANEL		1
	56	MK260E-PCP	PLASTIC CONTROL PANEL		1
	57	MK130E-DPI-115	DIGITAL CONTROLLER		1
	58	MK150E-RDC	REDUCTION 3/8" - 1/4"		1
	59	MK170E-T1/4	1 / 4" T CONNECTOR		1
	60	MK260E-RNT8	RIVET NUT M8		4
	61	MK90E-CBR	CABINET RIGHT		1
	62	M-CHN-6000	CABINET HANDLE (NEW)		4
	63	MK90E-CSG	CABINET STRIPPING		2
	64	M-FAS-6000	CABINET FASTENER		8
	65	MK90E-CSP	CABLE STRAP		6
	66	MK90E-RVT3,5	RIVET Ø3,5		6
	67	MK90E-CLT	CABINET LEFT		1
	68	MK90E-BLT615	BOLT M6x15		4
	69	MK90E-CAT	CABINET TOP		1
	70	MK260E-CG11	CABLE GLAND PG11		1
	71	MK130E-PWC	POWER CABLE		1
	72	MK170E-NIP1/4	1 / 4" NIPPLE		2
	73	N/A	N/A		-
	74	MK150E-FIT6	1 / 4" - 6mm FITTINGS		3

8.1 - ED & Spare Part List

PDRCF2300288 / EDRCF2300288 (230 V)

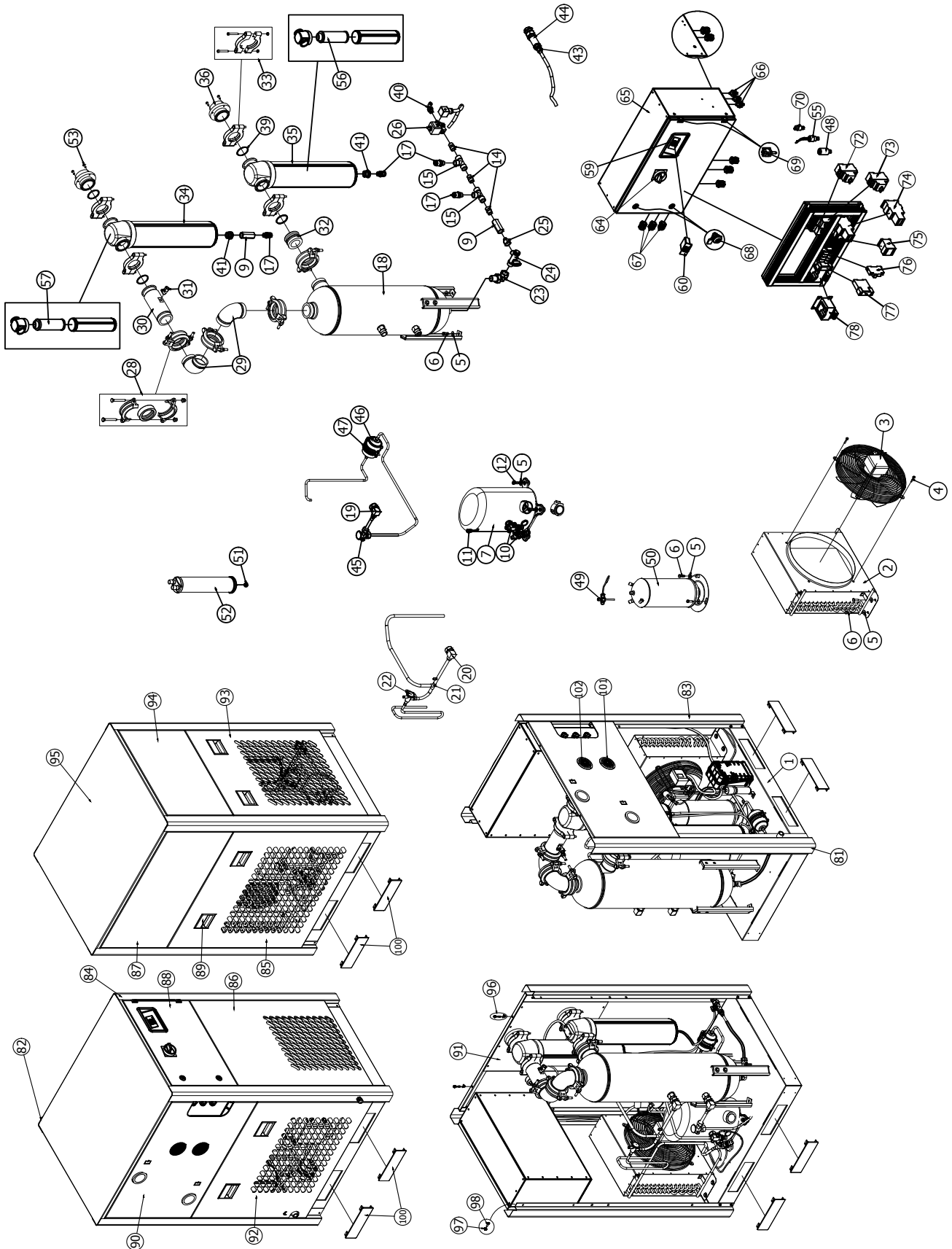

8.1 - ED & Spare Part List
PDRCF2300288 / EDRCF2300288 (230 V)

PART LIST						
DWG SIZE	ITEM NO.	PART NO		SPARE PART CODE	REV	QTY
	01	MK110E-CAB-US		CABINET BASE		1
	02	MK120E-CON		CONDANSER		1
	03	M-FMT-0700-400/460-3-50/60		FAN MOTOR		1
	04	MK260E-BLT830		BOLT M6x30		4
	05	MK260E-WHR22		WASHER Ø22x8,2x2,4		14
	06	MK260E-BLT825		BOLT M8x25		10
	07	M-CMP-0250-230-3-60		COMPRESSOR		1
	08	N/A		N/A		-
	09	MK170E-CHV		CHECK VALVE		2
	10	MK260E-RTA1		ROTOLOCK ADAPTOR1		2
	11	MK150E-STC		SETTING THE CONNECTION		1
	12	MK260E-BLT850		BOLT M8x50		4
	13	N/A		N/A		-
	14	MK170E-NIP1/4		1 / 4" NIPPLE		3
	15	MK170E-T1/4		1 / 4" T CONNECTOR		2
	16	N/A		N/A		-
	17	MK150E-FIT6		1 / 4" - 6mm FITTINGS		3
	18	MK110E-EXC		HEAT EXCHANGER		1
	19	MK260E-RTA2		ROTOLOCK ADAPTOR2		1
	20	MK260E-RTA3		ROTOLOCK ADAPTOR3		1
	21	MK260E-CPT1		CUPPER T1		1
	22	M-BYV-0400		BY-PASS VALVE		1
	23	MK260E-ELW1		ELBOW1		1
	24	M-DBV-0200		DRAIN BALL VALVE		1
	25	MK260E-DRN		DRAIN NUT		1
	26	MK150E-SLV-24		SOLENOID VALVE		1
	27	N/A		N/A		-
	28	MK260E-CPG1		COUPLING CLAMP1		4
	29	MK170E-ELW2		ELBOW2		2
	30	MK110E-CNK1		CONNECTION CIT1		1
	31	MK260E-BLV		BALL VALVE		1
	32	MK110E-CNK2		CONNECTION CIT2		1
	33	MK170E-CPG2		COUPLING CLAMP2		4
	34	MK130E-ELK-Y		COMPRESSED AIR FILTER KIT (Y)		1
	35	MK130E-ELK-X		COMPRESSED AIR FILTER KIT (X)		1
	36	MK110E-CNK3-US		CONNECTION CIT3		2
	37	N/A		N/A		-
	38	N/A		N/A		-
	39	MK170E-ORG		ORING		4
	40	MK170E-EWF		90° 1 / 4" - 6mm ELBOW		1
	41	MK260E-RDC		REDUCTION 1 / 2" - 1 / 4"		2
	42	N/A		N/A		-
	43	MK260E-FTT2		FITTING 2		1
	44	MK130E-DRS-NPT		DRAIN SLEEVE		1
	45	M-EXV-0250		EXPANSION VALVE		1
	46	M-DRI-0400		DRYER-DEHYDRATOR		1
	47	MK120E-FDC		FILTER DRIER CLAMP		1
	48	M-FNS-0200		FAN ON/OFF SWITCH		1
	49	MK260E-TDP		T ADAPTOR		1
	50	MK110E-RCV		LIQUID RECEIVER		1
	51	MK150E-NT10		NUT M10		1
	52	M-SPR-0400		SEPERATOR		1
	53	MK170E-BLT815		BOLT M8x15		8
	54	N/A		N/A		-
	55	M-HPS-0200		HIGH PRESSURE SWICH		1
	56	MK130E-FIE-X		COMPRESSED AIR FILTER (X)		1
	57	MK130E-FIE-Y		COMPRESSED AIR FILTER (Y)		1
	58	N/A		N/A		-
	59	MK130E-PCP		PLASTIC CONTROL PANEL		1
	60	MK130E-DPI-24		DIGITAL CONTROLLER		1
	61	N/A		N/A		-
	62	N/A		N/A		-
	63	N/A		N/A		-
	64	MK130E-MSW		MAIN SWITCH		1
	65	MK130E-ELB-US		ELECTRICAL BOX		1
	66	MK260E-SCF		SWITCH CONNECTION FITTING		3
	67	MK260E-CG16		CABLE GLAND PG16		8
	68	MK260E-DLK		DOOR LOCK		2
	69	MK260E-HNG		HINGE		2
	70	MK260E-LPS		LOW PRESSURE SWICH		1
	71	MK130E-ELP		ELECTRICAL PANEL		1
	72	M-FOP-0700-230-3-60		FAN OVERLOAD PROTECTOR		1
	73	M-COP-0700		COMPRESSOR OVERLOAD PROTECTOR		1
	74	M-CNT-0250-230		COMPRESSOR CONTACTOR		1
	75	M-FCN-1200		FAN CONTACTOR		1
	76	M-FHH-6000		HIGH VOLTAGE FUSE HOLDER		4
	77	M-PPR-6000		PHASE PROTECTION RELAY		1
	78	M-TRF-1600		TRANSFORMER		1
	79	N/A		N/A		-
	80	N/A		N/A		-
	81	MK110E-CAL1-US		CABINET LEG1		1
	82	MK110E-CAL2		CABINET LEG2		1
	83	MK110E-CAL3-US		CABINET LEG3		1
	84	MK110E-CAL4-US		CABINET LEG4		1
	85	MK110E-CLR-US		CABINET LOWER RIGHT		1
	86	MK110E-CFB-US		CABINET FRONT BOTTOM		1
	87	MK110E-CUR-US		CABINET UPPER RIGHT		1
	88	MK110E-CNP-US		CONTROLLER PANEL		1
	89	M-CHN-6000		CABINET HANDLE		6
	90	MK110E-CUL-US-T		CABINET UPPER LEFT		1
	91	MK110E-CAI		CABINET INSIDE		1
	92	MK110E-CBL-US		CABINET BOTTOM LEFT		1
	93	MK110E-CRB-US		CABINET REAR BOTTOM		1
	94	MK110E-CRT-US		CABINET REAR TOP		1
	95	MK110E-CAT-US		CABINET TOP		1
	96	M-FAS-6000		CABINET FASTENER		14
	97	M-NUT-6000		CAGE NUTS M6		24
	98	MK260E-BLT826		BOLT M8x25		24
	99	N/A		N/A		-
	100	MK190E-RMS		REMOVABLE SHIELD		4
	101	MK260E-LPG		LOW PRESSURE GAUGE		1
	102	MK260E-HPG		HIGH PRESSURE GAUGE		1

8.1 - ED & Spare Part List

PDRCF4600288 / EDRCF4600288 (460 V)

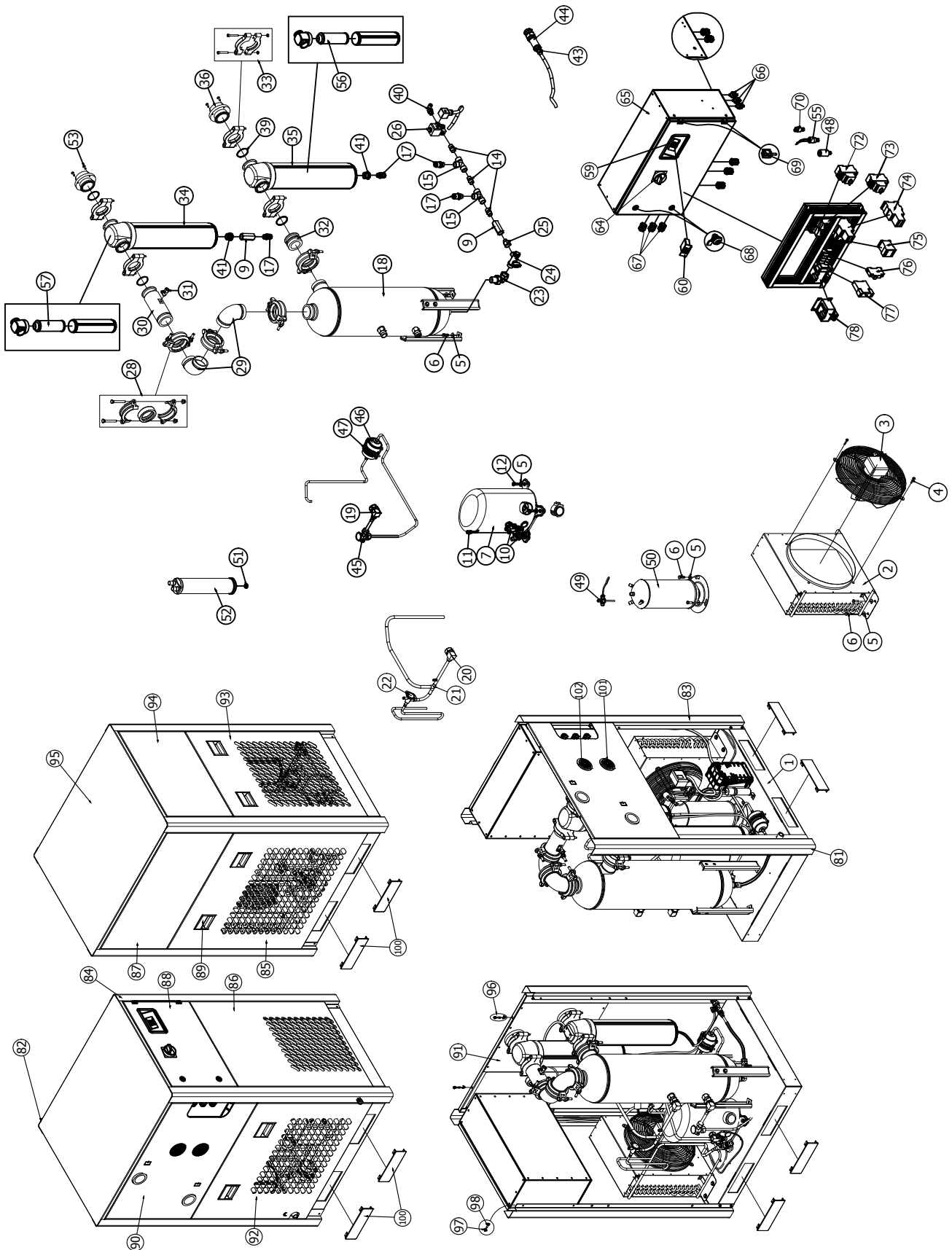

8.1 - ED & Spare Part List
PDRCF4600288 / EDRCF4600288 (460 V)

PART LIST						
DWG SIZE	ITEM NO.	PART NO		SPARE PART CODE	REV	QTY
	01	MK110E-CAB-US		CABINET BASE		1
	02	MK120E-CON		CONDANSER		1
	03	M-FM1-0700-400-460-3-50/60		FAN MOTOR		1
	04	MK260E-BLT630		BOLT M6x30		4
	05	MK260E-WHR22		WASHER Ø22x8,2x2,4		14
	06	MK260E-BLT825		BOLT M8x25		10
	07	M-CMP-0250-460-3-60		COMPRESSOR		1
	08	N/A		N/A		-
	09	MK170E-CHV		CHECK VALVE		2
	10	MK260E-RTA1		ROTOLOCK ADAPTOR1		2
	11	MK150E-STC		SETTING THE CONNECTION		1
	12	MK260E-BLT850		BOLT M8x50		4
	13	N/A		N/A		-
	14	MK170E-NIP1/4		1 / 4" NIPPLE		3
	15	MK170E-T1/4		1 / 4" T CONNECTOR		2
	16	N/A		N/A		-
	17	MK150E-FIT6		1 / 4" - 6mm FITTINGS		3
	18	MK110E-EXC		HEAT EXCHANGER		1
	19	MK260E-RTA2		ROTOLOCK ADAPTOR2		1
	20	MK260E-RTA3		ROTOLOCK ADAPTOR3		1
	21	MK260E-CPT1		CUPPER T1		1
	22	M-BYV-0400		BY-PASS VALVE		1
	23	MK260E-ELW1		ELBOW1		1
	24	M-DBV-0200		DRAIN BALL VALVE		1
	25	MK260E-DRN		DRAIN NUT		1
	26	MK150E-SLV-24		SOLENOID VALVE		1
	27	N/A		N/A		-
	28	MK260E-CPG1		COUPLING CLAMP1		4
	29	MK170E-ELW2		ELBOW2		2
	30	MK110E-CNK1		CONNECTION CIT1		1
	31	MK260E-BLV		BALL VALVE		1
	32	MK110E-CNK2		CONNECTION CIT2		1
	33	MK170E-CPG2		COUPLING CLAMP2		4
	34	MK130E-ELK-Y		COMPRESSED AIR FILTER KIT (Y)		1
	35	MK130E-ELK-X		COMPRESSED AIR FILTER KIT (X)		1
	36	MK110E-CNK3-US		CONNECTION CIT3		2
	37	N/A		N/A		-
	38	N/A		N/A		-
	39	MK170E-ORG		ORING		4
	40	MK170E-EWF		90° 1 / 4" - 6mm ELBOW		1
	41	MK260E-RDC		REDUCTION 1 / 2" - 1 / 4"		2
	42	N/A		N/A		-
	43	MK260E-FIT2		FITTING 2		1
	44	MK130E-DRS-NPT		DRAIN SLEEVE		1
	45	M-EXV-0250		EXPANSION VALVE		1
	46	M-DRI-0400		DRYER-DEHYDRATOR		1
	47	MK120E-FDC		FILTER DRIER CLAMP		1
	48	M-FNS-0200		FAN ON/OFF SWITCH		1
	49	MK260E-TDP		T ADAPTOR		1
	50	MK110E-RCV		LIQUID RECEIVER		1
	51	MK150E-NT10		NUT M10		1
	52	M-SPR-0400		SEPERATOR		1
	53	MK170E-BLT815		BOLT M8x15		8
	54	N/A		N/A		-
	55	M-HPS-0200		HIGH PRESSURE SWICH		1
	56	MK130E-FIE-X		COMPRESSED AIR FILTER (X)		1
	57	MK130E-FIE-Y		COMPRESSED AIR FILTER (Y)		1
	58	N/A		N/A		-
	59	MK130E-PCP		PLASTIC CONTROL PANEL		1
	60	MK130E-DPI-24		DIGITAL CONTROLLER		1
	61	N/A		N/A		-
	62	N/A		N/A		-
	63	N/A		N/A		-
	64	MK130E-MSW		MAIN SWITCH		1
	65	MK130E-ELB-US		ELECTRICAL BOX		1
	66	MK260E-SCF		SWITCH CONNECTION FITTING		3
	67	MK260E-CG16		CABLE GLAND PG16		8
	68	MK260E-DLK		DOOR LOCK		2
	69	MK260E-HNG		HINGE		2
	70	MK260E-LPS		LOW PRESSURE SWICH		1
	71	MK130E-ELP		ELECTRICAL PANEL		1
	72	M-FOP-0700		FAN OVERLOAD PROTECTOR		1
	73	M-COP-0325		COMPRESSOR OVERLOAD PROTECTOR		1
	74	M-CNT-MP		COMPRESSOR CONTACTOR		1
	75	M-FCN-1200		FAN CONTACTOR		1
	76	M-FHH-6000		HIGH VOLTAGE FUSE HOLDER		4
	77	M-PPR-6000		PHASE PROTECTION RELAY		1
	78	M-TRF-1600		TRANSFORMER		1
	79	N/A		N/A		-
	80	N/A		N/A		-
	81	MK110E-CAL1-US		CABINET LEG1		1
	82	MK110E-CAL2		CABINET LEG2		1
	83	MK110E-CAL3-US		CABINET LEG3		1
	84	MK110E-CAL4-US		CABINET LEG4		1
	85	MK110E-CLR-US		CABINET LOWER RIGHT		1
	86	MK110E-CFB-US		CABINET FRONT BOTTOM		1
	87	MK110E-CUR-US		CABINET UPPER RIGHT		1
	88	MK110E-CNP-US		CONTROLLER PANEL		1
	89	M-CHN-6000		CABINET HANDLE		6
	90	MK110E-CUL-US-T		CABINET UPPER LEFT		1
	91	MK110E-CAI		CABINET INSIDE		1
	92	MK110E-CBL-US		CABINET BOTTOM LEFT		1
	93	MK110E-CRB-US		CABINET REAR BOTTOM		1
	94	MK110E-CRT-US		CABINET REAR TOP		1
	95	MK110E-CAT-US		CABINET TOP		1
	96	M-FAS-6000		CABINET FASTENER		14
	97	M-NUT-6000		CAGE NUTS M6		24
	98	MK260E-BLT826		BOLT M8x25		24
	99	N/A		N/A		-
	100	MK190E-RMS		REMOVABLE SHIELD		4
	101	MK260E-LPG		LOW PRESSURE GAUGE		1
	102	MK260E-HPG		HIGH PRESSURE GAUGE		1

8.1 - ED & Spare Part List

PDRCF2300575 / EDRCF2300575 (230 V)

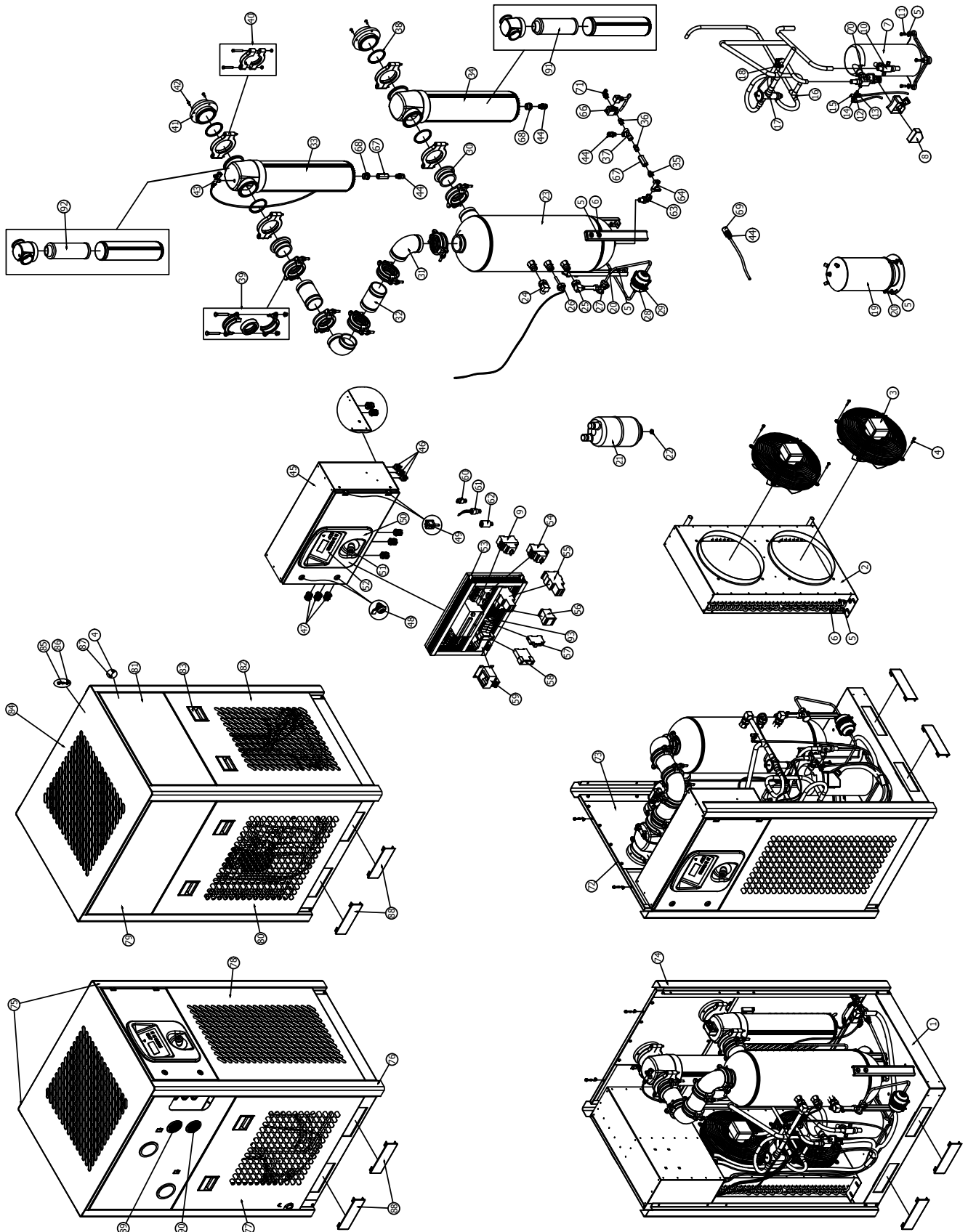

8.1 - ED & Spare Part List
PDRCF2300575 / EDRCF2300575 (230 V)

PART LIST						
DWG SIZE	ITEM NO.	PART NO		SPARE PART CODE	REV	QTY
	01	MK150E-CAB		CABINET BASE		1
	02	MK140E-CON		CONDANSER		1
	03	M-FMT-0700-400/460-3-50/60		FAN MOTOR		2
	04	MK260E-BLT630		BOLT M6x30		30
	05	MK260E-WHR22		WASHER 22x8,2x2,4		23
	06	MK150E-BLT825		BOLT M8x25		13
	07	MK140E-CMP-230-3-60		COMPRESSOR		1
	08	MK150E-CEC		COMPRESSOR ELECTRICAL BOX - COVER		1
	09	M-FOP-0700-230-3-60		FAN OVERLOAD PROTECTOR		2
	10	MK160E-RTA1		ROTOLOCK ADAPTOR1		1
	11	MK260E-BLT850		BOLT M8x50		4
	12	M-TSC-6000		T CONNECTION FOR SWITCH CAPILLARY		1
	13	MK260E-CTC1		CAPPILARY TUBE CONNECTION1		1
	14	MK260E-CTC2		CAPPILARY TUBE CONNECTION2		2
	15	MK260E-STC		SETTING THE CONNECTION		1
	16	MK260E-CPT1		CUPPER T1		2
	17	M-BYV-1200		BY-PASS VALVE		1
	18	MK260E-CPT2		CUPPER T2		1
	19	MK150E-RCV		LIQUID RECEIVER		1
	20	MK260E-BLT830		BOLT M8x30		6
	21	M-SPR-0850		SEPARATOR		1
	22	MK150E-NT10		NUT M10		1
	23	MK260E-EXC		HEAT EXCHANGER		1
	24	M-RTA-5000-1		ROTOLOCK VALVE ADAPTOR FOR HEAT EXCHANGER		1
	25	MK260E-RTA3		ROTOLOCK ADAPTOR3		1
	26	MK150E-SSD		SENSOR ADAPTOR		1
	27	M-EXV-1000		EXPANSION VALVE		1
	28	M-DRI-0400		DRYER-DEHYDRATOR		1
	29	M-CLP-1200		CLAMP		1
	30	MK150E-CNK1		CONNECTION CIT1		2
	31	MK170E-ELW1		ELBOW1		2
	32	MK150E-CPP		COUPLING PIPE		2
	33	MK150E-ELK-Y		COMPRESSED AIR FILTER KIT (Y)		1
	34	MK150E-ELK-X		COMPRESSED AIR FILTER KIT (X)		1
	35	MK260E-DRN		DRAIN NUT		1
	36	MK170E-NIP1/4		1 / 4" NIPPLE		2
	37	MK170E-T1/4		1 / 4" T CONNECTOR		1
	38	MK170E-ORG		ORING		1
	39	MK260E-CPG1		COUPLING CLAMP 1		6
	40	MK170E-CPG2		COUPLING CLAMP 2		4
	41	MK170E-CNK2-NPT		CONNECTION CIT2		2
	42	MK170E-BLT815		BOLT M8x15		8
	43	MK260E-BLV		BALL VALVE		1
	44	MK150E-FIT6		1 / 4" - 6mm FITTINGS		4
	45	MK150E-ELB-US		ELECTRICAL BOX		1
	46	MK260E-SCF		SWITCH CONNECTION FITTING		3
	47	M-CCP-6000		CONDUIT FOR CONTROL PANEL		8
	48	MK260E-DLK		DOOR LOCK		2
	49	MK260E-HNG		HINGE		2
	50	MK260E-PCP-ESD3		PLASTIC CONTROL PANEL		1
	51	MK260E-MSW		MAIN SWITCH		1
	52	MK260E-ES2		ESD3 CONTROLLER		1
	53	MK150E-ELP		ELECTRICAL PANEL		1
	54	M-COP-1600		COMPRESSOR OVERLOAD PROTECTOR		1
	55	M-CNT-1600		COMPRESSOR CONTACTOR		1
	56	M-FCN-1200		FAN CONTACTOR		2
	57	M-FHH-6000		HIGH VOLTAGE FUSE HOLDER		4
	58	M-PPR-6000		PHASE PROTECTION RELAY		1
	59	M-TRF-1600		TRANSFORMER		1
	60	MK260E-LPS		LOW PRESSURE SWICH		1
	61	M-HPS-0200		HIGH PRESSURE SWITCH		1
	62	M-FNS-0200		FAN ON/OFF SWITCH		1
	63	MK260E-ELW2		ELBOW2		1
	64	M-DBV-6000		DRAIN BALL VALVE		1
	65	N/A		N/A		-
	66	MK150E-SLV-24		SOLENOID VALVE		1
	67	MK170E-CHV		CHECK VALVE		2
	68	MK260E-RDC		REDUCTION 1 / 2" - 1 / 4"		2
	69	MK150E-DRS-NPT		DRAIN SLEEVE		1
	70	MK150E-RTA2		ROTOLOCK ADAPTOR2		1
	71	MK170E-EWF		ELBOW FITTINGS		2
	72	MK150E-CUL-US		CABINET UPPER LEFT		1
	73	MK150E-CAI		CABINET INSIDE		1
	74	MK150E-CAL1		CABINET LEG1		1
	75	MK150E-CAL2		CABINET LEG2		2
	76	MK150E-CAL3		CABINET LEG3		1
	77	MK150E-CBL		CABINET BOTTOM LEFT		1
	78	MK150E-CFB		CABINET FRONT BOTTOM		1
	79	MK150E-CUR		CABINET UPPER RIGHT		1
	80	MK150E-CLR		CABINET LOWER RIGHT		1
	81	MK150E-CRT		CABINET REAR TOP		1
	82	MK150E-CRB		CABINET REAR BOTTOM		1
	83	M-CHN-6000		CABINET HANDLE		1
	84	MK150E-CAT		CABINET TOP		1
	85	M-STU-6000		CABINET STUD AND NUT		14
	86	M-FAS-6000		CABINET FASTENER		14
	87	M-NUT-6000		CAGE NUT		26
	88	MK190E-RMS		REMOVABLE SHIELD		4
	89	MK260E-LPG		LOW PRESSURE GAUGE		1
	90	MK260E-HPG		HIGH PRESSURE GAUGE		1
	91	MK150E-FIE-X		COMPRESSED AIR FILTER (X)		1
	92	MK150E-FIE-Y		COMPRESSED AIR FILTER (Y)		1
	93	M-FHL-6000		LOW VOLTAGE FUSE HOLDER		1

8.1 - ED & Spare Part List

PDRCF4600575 / EDRCF4600575 (460 V)

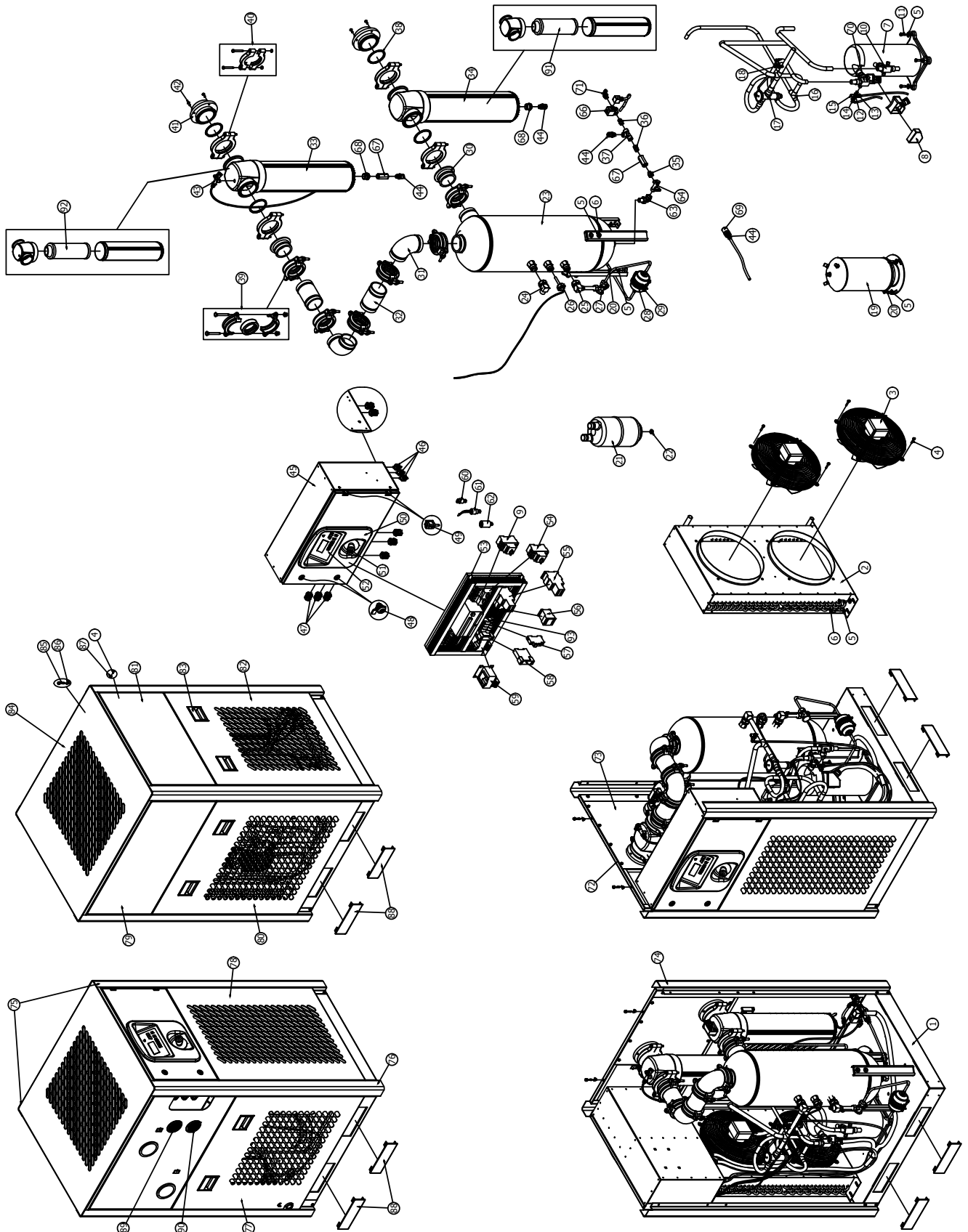

8.1 - ED & Spare Part List
PDRCF4600575 / EDRCF4600575 (460 V)

PART LIST						
DWG SIZE	ITEM NO.	PART NO		SPARE PART CODE	REV	QTY
	01	MK150E-CAB		CABINET BASE		1
	02	MK140E-CON		CONDANSER		1
	03	M-FMT-0700-400/460-3-50/60		FAN MOTOR		2
	04	MK260E-BLT630		BOLT M6x30		30
	05	MK260E-WHR22		WASHER 22x8,2x2,4		23
	06	MK150E-BLT825		BOLT M8x25		13
	07	MK140E-CMP		COMPRESSOR		1
	08	MK150E-CEC		COMPRESSOR ELECTRICAL BOX - COVER		1
	09	M-FOP-0700		FAN OVERLOAD PROTECTOR		2
	10	MK160E-RTA1		ROTOLOCK ADAPTOR1		1
	11	MK260E-BLT850		BOLT M8x50		4
	12	M-TSC-6000		T CONNECTION FOR SWITCH CAPILLARY		1
	13	MK260E-CTC1		CAPPILARY TUBE CONNECTION1		1
	14	MK260E-CTC2		CAPPILARY TUBE CONNECTION2		2
	15	MK260E-STC		SETTING THE CONNECTION		1
	16	MK260E-CPT1		CUPPER T1		2
	17	M-BYV-1200		BY-PASS VALVE		1
	18	MK260E-CPT2		CUPPER T2		1
	19	MK150E-RCV		LIQUID RECEIVER		1
	20	MK260E-BLT830		BOLT M8x30		6
	21	M-SPR-0850		SEPARATOR		1
	22	MK150E-NT10		NUT M10		1
	23	MK260E-EXC		HEAT EXCHANGER		1
	24	M-RTA-5000-1		ROTOLOCK VALVE ADAPTOR FOR HEAT EXCHANGER		1
	25	MK260E-RTA3		ROTOLOCK ADAPTOR3		1
	26	MK150E-SSD		SENSOR ADAPTOR		1
	27	M-EXV-1000		EXPANSION VALVE		1
	28	M-DRI-0400		DRYER-DEHYDRATOR		1
	29	M-CLP-1200		CLAMP		1
	30	MK150E-CNK1		CONNECTION CIT1		2
	31	MK170E-ELW1		ELBOW1		2
	32	MK150E-CPP		COUPLING PIPE		2
	33	MK150E-ELK-Y		COMPRESSED AIR FILTER KIT (Y)		1
	34	MK150E-ELK-X		COMPRESSED AIR FILTER KIT (X)		1
	35	MK260E-DRN		DRAIN NUT		1
	36	MK170E-NIP1/4		1 / 4" NIPPLE		2
	37	MK170E-T1/4		1 / 4" T CONNECTOR		1
	38	MK170E-ORG		ORING		1
	39	MK260E-CPG1		COUPLING CLAMP 1		6
	40	MK170E-CPG2		COUPLING CLAMP 2		4
	41	MK170E-CNK2-NPT		CONNECTION CIT2		2
	42	MK170E-BLT815		BOLT M8x15		8
	43	MK260E-BLV		BALL VALVE		1
	44	MK150E-FIT6		1 / 4" - 6mm FITTINGS		4
	45	MK150E-ELB-US		ELECTRICAL BOX		1
	46	MK260E-SCF		SWITCH CONNECTION FITTING		3
	47	M-CCP-6000		CONDUIT FOR CONTROL PANEL		8
	48	MK260E-DLK		DOOR LOCK		2
	49	MK260E-HNG		HINGE		2
	50	MK260E-PCP-ESD3		PLASTIC CONTROL PANEL		1
	51	MK260E-MSW		MAIN SWITCH		1
	52	MK260E-ES2		ESD3 CONTROLLER		1
	53	MK150E-ELP		ELECTRICAL PANEL		1
	54	MK150E-COP		COMPRESSOR OVERLOAD PROTECTOR		1
	55	M-CNT-1200		COMPRESSOR CONTACTOR		1
	56	M-FCN-1200		FAN CONTACTOR		2
	57	M-FHH-6000		HIGH VOLTAGE FUSE HOLDER		4
	58	M-PPR-6000		PHASE PROTECTION RELAY		1
	59	M-TRF-1600		TRANSFORMER		1
	60	MK260E-LPS		LOW PRESSURE SWICH		1
	61	M-HPS-0200		HIGH PRESSURE SWITCH		1
	62	M-FNS-0200		FAN ON/OFF SWITCH		1
	63	MK260E-ELW2		ELBOW2		1
	64	M-DBV-6000		DRAIN BALL VALVE		1
	65	N/A		N/A		-
	66	MK150E-SLV-24		SOLENOID VALVE		1
	67	MK170E-CHV		CHECK VALVE		2
	68	MK260E-RDC		REDUCTION 1 / 2" - 1 / 4"		2
	69	MK150E-DRS-NPT		DRAIN SLEEVE		1
	70	MK150E-RTA2		ROTOLOCK ADAPTOR2		1
	71	MK170E-EWF		ELBOW FITTINGS		2
	72	MK150E-CUL-US		CABINET UPPER LEFT		1
	73	MK150E-CAI		CABINET INSIDE		1
	74	MK150E-CAL1		CABINET LEG1		1
	75	MK150E-CAL2		CABINET LEG2		2
	76	MK150E-CAL3		CABINET LEG3		1
	77	MK150E-CBL		CABINET BOTTOM LEFT		1
	78	MK150E-CFB		CABINET FRONT BOTTOM		1
	79	MK150E-CUR		CABINET UPPER RIGHT		1
	80	MK150E-CLR		CABINET LOWER RIGHT		1
	81	MK150E-CRT		CABINET REAR TOP		1
	82	MK150E-CRB		CABINET REAR BOTTOM		1
	83	M-CHN-6000		CABINET HANDLE		1
	84	MK150E-CAT		CABINET TOP		1
	85	M-STU-6000		CABINET STUD AND NUT		14
	86	M-FAS-6000		CABINET FASTENER		14
	87	M-NUT-6000		CAGE NUT		26
	88	MK190E-RMS		REMOVABLE SHIELD		4
	89	MK260E-LPG		LOW PRESSURE GAUGE		1
	90	MK260E-HPG		HIGH PRESSURE GAUGE		1
	91	MK150E-FIE-X		COMPRESSED AIR FILTER (X)		1
	92	MK150E-FIE-Y		COMPRESSED AIR FILTER (Y)		1
	93	M-FHL-6000		LOW VOLTAGE FUSE HOLDER		1

8.1 - ED & Spare Part List

PDRCF4600850 / EDRCF4600850

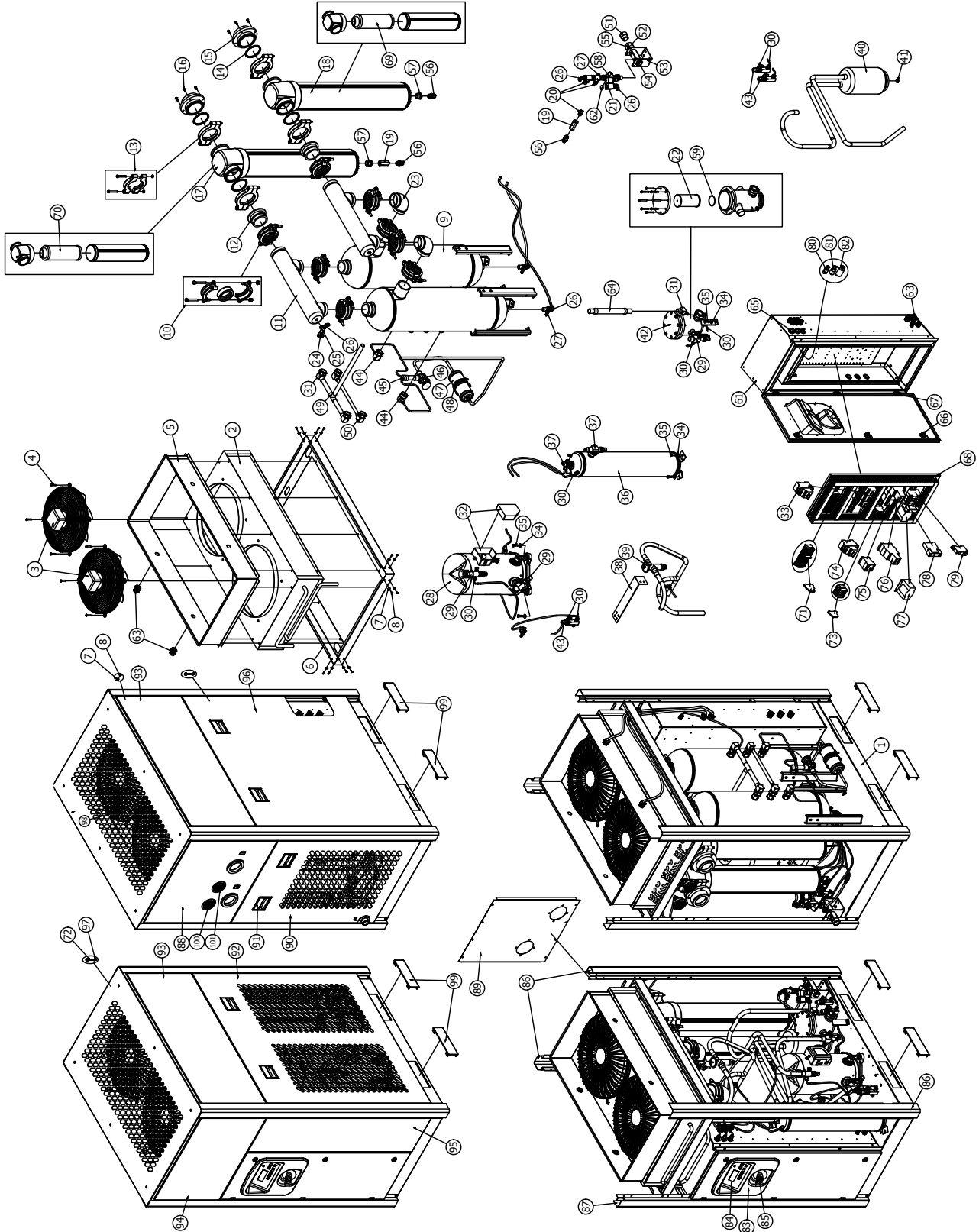

8.1 - ED & Spare Part List
PDRCF4600850 / EDRCF4600850

PART LIST						
DWG SIZE	ITEM NO.	PART NO		SPARE PART CODE	REV	QTY
	01	MK170E-CAB		CABINET BASE		1
	02	MK170E-CON		CONDENSER		1
	03	M-FMT-1200-400/460-3-50/60		FAN MOTOR		2
	04	MK260E-BLT630		BOLT M6x30		8
	05	MK170E-FPRT		FAN PROTECTOR		1
	06	MK170E-CRP		CONDENSER REINFORCEMENT PLATE		1
	07	M-NUT-6000		CAGE NUT M6		48
	08	MK260E-BLT630		BOLT M6x30		48
	09	MK170E-EXC		HEAT EXCHANGER		2
	10	MK260E-CPG1		COUPLING CLAMP 1		8
	11	MK170E-CLL		COLLECTOR		2
	12	MK170E-CNK1		CONNECTION KIT 1		2
	13	MK170E-CPG2		COUPLING CLAMP 2		4
	14	MK170E-ORG		ORING		4
	15	MK170E-CNK2-NPT		CONNECTION KIT 2		2
	16	MK170E-BLT815		BOLT M8x15		8
	17	MK170E-ELK-Y		COMPRESSED AIR FILTER KIT (Y)		1
	18	MK170E-ELK-X		COMPRESSED AIR FILTER KIT (X)		1
	19	MK170E-CHV		CHECK VALVE		2
	20	MK170E-NIP1/4		1 / 4" NIPPLE		3
	21	M-SLV-6000-24		SOLENOID VALVE		1
	22	M-OSE-1600		OIL SEPARATOR ELEMENT		1
	23	MK170E-ELW		ELBOW		2
	24	MK260E-BLV		BALL VALVE		1
	25	MK260E-TCN		T CONNECTION		1
	26	MK260E-EWF		ELBOW FITTINGS		6
	27	M-DBV-6000		DRAIN VALVE		2
	28	MK160E-CMP		COMPRESSOR		1
	29	MK260E-RTA1		ROTOLOCK ADAPTOR1		3
	30	M-CPF-6000-90		1/4 90° ORIFICE CUPPER PIPE FITTING		15
	31	M-RTA-5000-1		ROTOLOCK VALVE ADAPTOR FOR HEAT EXCHANGER		3
	32	MK160E-CEC		COMPRESSOR ELECTRICAL BOX - COVER		1
	33	M-COP-1600		COMPRESSOR OVERLOAD PROTECTION		1
	34	MK260E-WHR22		WASHER 22x8.2x2.4		10
	35	MK260E-BLT850		BOLT M8x50		10
	36	MK170E-RCV		LIQUID RECEIVER		1
	37	MK260E-RTA2		ROTOLOCK ADAPTOR2		2
	38	MK170E-RSM		REINFORCEMENT SHEET METAL		1
	39	M-BYV-1200		BY-PASS VALVE		1
	40	MK160E-SPR		SEPERATOR		1
	41	MK170E-NUT10		NUT M10		1
	42	M-OSP-1600		OIL SEPARATOR		1
	43	MK260E-RSV		ROTOLOCK SERVICE VALVE		3
	44	MK260E-RTA4		ROTOLOCK ADAPTOR4		2
	45	MK190E-DST		DISTRIBUTOR		1
	46	M-EXV-1200		EXPANSION VALVE		1
	47	M-DRI-0700		DRYER-DEHYDRATOR		1
	48	M-CLP-1200		CLAMP		1
	49	MK260E-CPT		CUPPER T		2
	50	M-RTA-5000-2		ROTOLOCK VALVE ADAPTOR FOR HEAT EXCHANGER		2
	51	MK260E-DRS-NPT		DRAIN SLEEVE		1
	52	MK190E-DRM		DRAIN MANIFOLD		1
	53	MK260E-MRS		MANIFOLD REINFORCEMENT SHEET METAL		1
	54	MK260E-MBC1		MANIFOLD BLIND CAP1		1
	55	MK260E-MBC2		MANIFOLD BLIND CAP2		1
	56	MK260E-FTT		FITTINGS		4
	57	MK260E-RDC		REDUCTION 1 / 2" - 1 / 4"		2
	58	M-MMV-6000		MEMBRAN VALVE		1
	59	M-OSO-1600		OIL SEPARATOR ORING		1
	60	N/A		N/A		-
	61	MK170E-ELB-US		ELECTRICAL BOX		1
	62	M-MMM-6000		MEMBRANE		1
	63	M-CCP-6000		CONDUIT FOR CONTROL PANEL		10
	64	MK210E-ASF		ASTROFLEX		1
	65	MK260E-SCF		SWITCH CONNECTION FITTING		3
	66	MK260E-DLK		DOOR LOCK		3
	67	MK260E-HNG		HINGE		3
	68	MK170E-ELP		ELECTRICAL PANEL		1
	69	MK170E-FIE-X		COMPRESSED AIR FILTER (X)		1
	70	MK170E-FIE-Y		COMPRESSED AIR FILTER (Y)		1
	71	M-FHL-6000		LOW VOLTAGE FUSE HOLDER		1
	72	M-STU-6000		CABINET STUD AND NUT		14
	73	M-PWC-1200		POWER CONNECTOR		3
	74	M-FOP-1200		FAN OVERLOAD PROTECTION		1
	75	M-FCN-1200		FAN CONTACTOR		2
	76	M-CNT-1200		COMPRESSOR CONTACTOR		1
	77	M-TRF-1600		TRANSFORMER		1
	78	M-PPR-6000		PHASE PROTECTION RELAY		1
	79	M-FHH-6000		HIGH VOLTAGE FUSE HOLDER		4
	80	MK260E-LPS		LOW PRESSURE SWITCH		1
	81	M-HPS-0200		HIGH PRESSURE SWITCH		1
	82	M-FNS-0200		FAN ON/OFF SWITCH		1
	83	MK260E-PCP-ESD3		PLASTIC CONTROL PANEL		1
	84	MK260E-DCC-24		ADVANCED DIGITAL CONTROLLER		1
	85	MK260E-MSW		MAIN SWITCH		1
	86	MK170E-CAL1		CABINET LEG1		3
	87	MK170E-CAL2		CABINET LEG2		1
	88	MK170E-CRT-US		CABINET REAR TOP		1
	89	MK170E-CAI		CABINET INSIDE		1
	90	MK170E-CRB		CABINET REAR BOTTOM		1
	91	M-CHN-6000		CABINET HANDLE		6
	92	MK170E-CSB1		CABINET SIDE BOTTOM1		1
	93	MK170E-CST		CABINET SIDE TOP		2
	94	MK170E-CFT		CABINET FRONT TOP		1
	95	MK170E-CFB		CABINET FRONT BOTTOM		1
	96	MK170E-CSB2		CABINET SIDE BOTTOM2		1
	97	M-FAS-6000		CABINET FASTENER		14
	98	MK170E-CAT		CABINET TOP		1
	99	MK190E-RMS		REMOVABLE SHIELD		4
	100	MK260E-LPG		LOW PRESSURE GAUGE		1
	101	MK260E-HPG		HIGH PRESSURE GAUGE		1

8.1 - ED & Spare Part List

PDRCF4601200 / EDRCF4601200

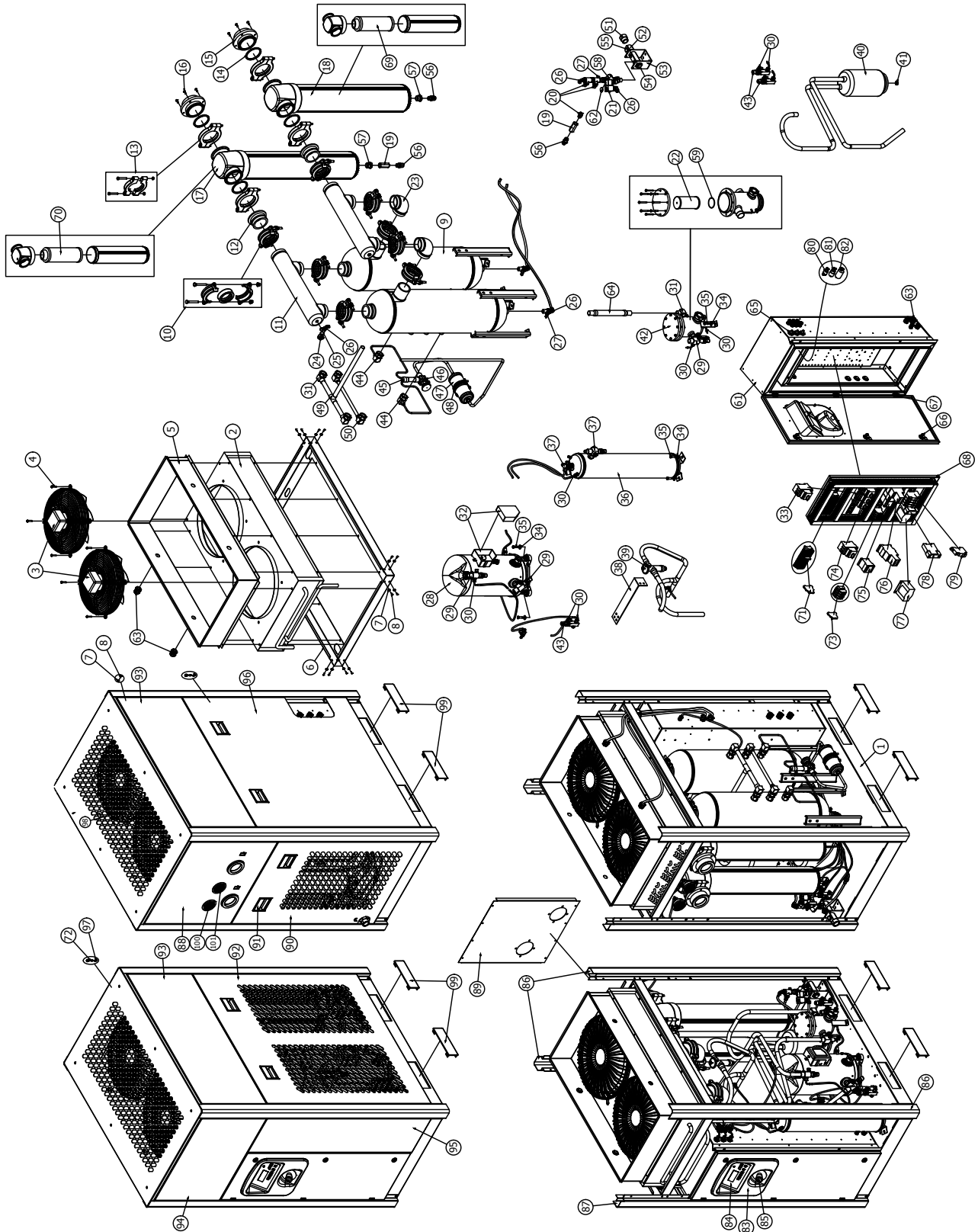

8.1 - ED & Spare Part List
PDRCF4601200 / EDRCF4601200

PART LIST						
DWG SIZE	ITEM NO.	PART NO		SPARE PART CODE	REV	QTY
	01	MK170E-CAB		CABINET BASE		1
	02	MK170E-CON		CONDENSER		1
	03	M-FMT-1200-400/460-3-50/60		FAN MOTOR		2
	04	MK260E-BLT630		BOLT M6x30		8
	05	MK170E-FPRT		FAN PROTECTOR		1
	06	MK170E-CRP		CONDENSER REINFORCEMENT PLATE		1
	07	M-NUT-6000		CAGE NUT M6		48
	08	MK260E-BLT630		BOLT M6x30		48
	09	MK170E-EXC		HEAT EXCHANGER		2
	10	MK260E-CPG1		COUPLING CLAMP 1		8
	11	MK170E-CLL		COLLECTOR		2
	12	MK170E-CNK1		CONNECTION KIT 1		2
	13	MK170E-CPG2		COUPLING CLAMP 2		4
	14	MK170E-ORG		ORING		4
	15	MK170E-CNK2-NPT		CONNECTION KIT 2		2
	16	MK170E-BLT815		BOLT M8x15		8
	17	MK170E-ELK-Y		COMPRESSED AIR FILTER KIT (Y)		1
	18	MK170E-ELK-X		COMPRESSED AIR FILTER KIT (X)		1
	19	MK170E-CHV		CHECK VALVE		2
	20	MK170E-NIP1/4		1 / 4" NIPPLE		3
	21	M-SLV-6000-24		SOLENOID VALVE		1
	22	M-OSE-1600		OIL SEPARATOR ELEMENT		1
	23	MK170E-ELW		ELBOW		2
	24	MK260E-BLV		BALL VALVE		1
	25	MK260E-TCN		T CONNECTION		1
	26	MK260E-EWF		ELBOW FITTINGS		6
	27	M-DBV-6000		DRAIN VALVE		2
	28	M-CMP-1000-460-3-60		COMPRESSOR		1
	29	MK260E-RTA1		ROTOLOCK ADAPTOR1		3
	30	M-CPF-6000-90		1/4 90° ORIFICE COPPER PIPE FITTING		15
	31	M-RTA-5000-1		ROTOLOCK VALVE ADAPTOR FOR HEAT EXCHANGER		3
	32	MK160E-CEC		COMPRESSOR ELECTRICAL BOX - COVER		1
	33	M-COP-1600		COMPRESSOR OVERLOAD PROTECTION		1
	34	MK260E-WHR22		WASHER 22x8,2x2,4		10
	35	MK260E-BLT850		BOLT M8x50		10
	36	MK170E-RCV		LIQUID RECEIVER		1
	37	MK260E-RTA2		ROTOLOCK ADAPTOR2		2
	38	MK170E-RSM		REINFORCEMENT SHEET METAL		1
	39	M-BYV-1200		BY-PASS VALVE		1
	40	MK160E-SPR		SEPERATOR		1
	41	MK170E-NUT10		NUT M10		1
	42	M-OSP-1600		OIL SEPARATOR		1
	43	MK260E-RSV		ROTOLOCK SERVICE VALVE		3
	44	MK260E-RTA4		ROTOLOCK ADAPTOR4		2
	45	MK190E-DST		DISTRIBUTOR		1
	46	M-EXV-1200		EXPANSION VALVE		1
	47	M-DRI-0700		DRYER-DEHYDRATOR		1
	48	M-CLP-1200		CLAMP		1
	49	MK260E-CPT		CUPPER T		2
	50	M-RTA-5000-2		ROTOLOCK VALVE ADAPTOR FOR HEAT EXCHANGER		2
	51	MK260E-DRS-NPT		DRAIN SLEEVE		1
	52	MK190E-DRM		DRAIN MANIFOLD		1
	53	MK260E-MRS		MANIFOLD REINFORCEMENT SHEET METAL		1
	54	MK260E-MBC1		MANIFOLD BLIND CAP1		1
	55	MK260E-MBC2		MANIFOLD BLIND CAP2		1
	56	MK260E-FTT		FITTINGS		4
	57	MK260E-RDC		REDUCTION 1 / 2" - 1 / 4"		2
	58	M-MMV-6000		MEMBRAN VALVE		1
	59	M-OSO-1600		OIL SEPARATOR ORING		1
	60	N/A		N/A		-
	61	MK170E-ELB-US		ELECTRICAL BOX		1
	62	M-MMM-6000		MEMBRANE		1
	63	M-CCP-6000		CONDUIT FOR CONTROL PANEL		10
	64	MK210E-ASF		ASTROFLEX		1
	65	MK260E-SCF		SWITCH CONNECTION FITTING		3
	66	MK260E-DLK		DOOR LOCK		3
	67	MK260E-HNG		HINGE		3
	68	MK170E-ELP		ELECTRICAL PANEL		1
	69	MK170E-FIE-X		COMPRESSED AIR FILTER (X)		1
	70	MK170E-FIE-Y		COMPRESSED AIR FILTER (Y)		1
	71	M-FHL-6000		LOW VOLTAGE FUSE HOLDER		1
	72	M-STU-6000		CABINET STUD AND NUT		14
	73	M-PWC-1200		POWER CONNECTOR		3
	74	M-FOP-1200		FAN OVERLOAD PROTECTION		1
	75	M-FCN-1200		FAN CONTACTOR		2
	76	M-CNT-1200		COMPRESSOR CONTACTOR		1
	77	M-TRF-1600		TRANSFORMER		1
	78	M-PPR-6000		PHASE PROTECTION RELAY		1
	79	M-FHH-6000		HIGH VOLTAGE FUSE HOLDER		4
	80	MK260E-LPS		LOW PRESSURE SWITCH		1
	81	M-HPS-0200		HIGH PRESSURE SWITCH		1
	82	M-FNS-0200		FAN ON/OFF SWITCH		1
	83	MK260E-PCP-ESD3		PLASTIC CONTROL PANEL		1
	84	MK260E-DCC-24		ADVANCED DIGITAL CONTROLLER		1
	85	MK260E-MSW		MAIN SWITCH		1
	86	MK170E-CAL1		CABINET LEG1		3
	87	MK170E-CAL2		CABINET LEG2		1
	88	MK170E-CRT-US		CABINET REAR TOP		1
	89	MK170E-CAI		CABINET INSIDE		1
	90	MK170E-CRB		CABINET REAR BOTTOM		1
	91	M-CHN-6000		CABINET HANDLE		6
	92	MK170E-CSB1		CABINET SIDE BOTTOM1		1
	93	MK170E-CST		CABINET SIDE TOP		2
	94	MK170E-CFT		CABINET FRONT TOP		1
	95	MK170E-CFB		CABINET FRONT BOTTOM		1
	96	MK170E-CSB2		CABINET SIDE BOTTOM2		1
	97	M-FAS-6000		CABINET FASTENER		14
	98	MK170E-CAT		CABINET TOP		1
	99	MK190E-RMS		REMOVABLE SHIELD		4
	100	MK260E-LPG		LOW PRESSURE GAUGE		1
	101	MK260E-HPG		HIGH PRESSURE GAUGE		1

8.1 - ED & Spare Part List

PDRCF4601600 / EDRCF4601600

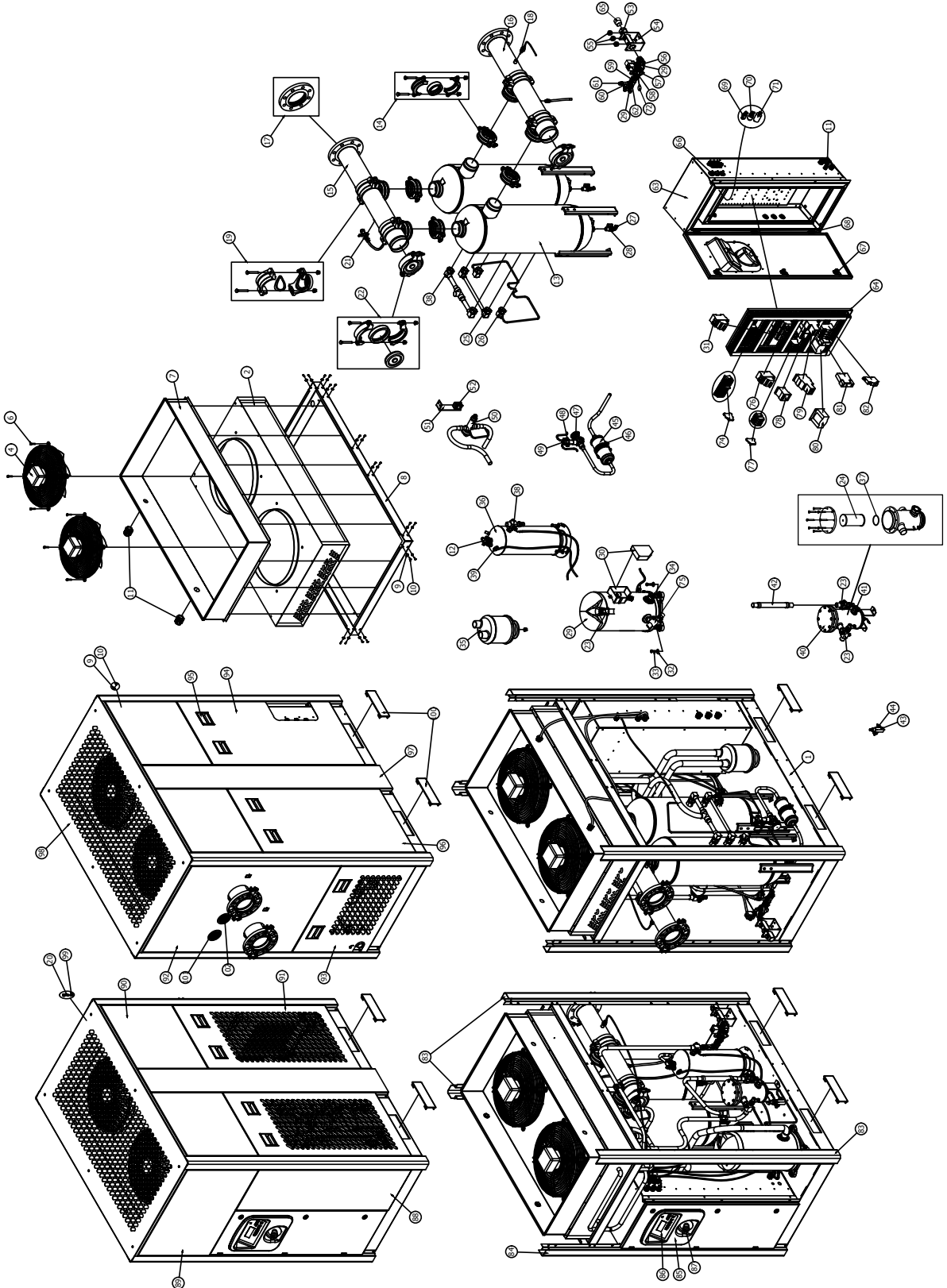

8.1 - ED & Spare Part List
PDRCF4601600 / EDRCF4601600

PART LIST						
DWG SIZE	ITEM NO.	PART NO		SPARE PART CODE	REV	QTY
	01	MK190E-CAB		CABINET BASE		1
	02	MK190E-CON		CONDANSER		1
	03	N/A		N/A		-
	04	M-FMT-1600-460-3-60		FAN MOTOR		2
	05	N/A		N/A		-
	06	MK260E-BLT630		BOLT M8x30		8
	07	MK190E-FPRT		FAN PROTECTOR		1
	08	MK190E-CRP		CONDENSER REINFORCEMENT PLATE		1
	09	M-NUT-6000		CAGE NUT M6		58
	10	MK260E-BLT630		BOLT M6x30		58
	11	M-CCP-6000		CONDUIT FOR CONTROL PANEL		8
	12	MK150E-RTA2		ROTOLOCK ADAPTOR2		2
	13	MK260E-EXC		HEAT EXCHANGER		2
	14	MK260E-CPG1		COUPLING CLAMP 1		4
	15	MK190E-CLLT		COLLECTOR TOP		1
	16	MK190E-CLLB		COLLECTOR BOTTOM		1
	17	MK210E-FLG-US		FLANGE		2
	18	M-SCF-6000		SENSOR CONNECTION FITTING		1
	19	MK210E-CPG3		COUPLING CLAMP 3		4
	20	M-STU-6000		CABINET STUD AND NUT		14
	21	MK260E-BLA		BALL VALVE G 1/4"		1
	22	MK210E-CPG4		COUPLING CLAMP 4		2
	23	MK160E-RTA2		ROTOLOCK ADAPTOR2		2
	24	M-OSE-1600		OIL SEPARATOR ELEMENT		1
	25	M-RTA-5000-2		ROTOLOCK VALVE ADAPTOR FOR HEAT EXCHANGER		2
	26	MK260E-RTA4		ROTOLOCK ADAPTOR4		2
	27	MK260E-EWF1		ELBOW FITTINGS1		4
	28	M-CPF-6000-90		1/4 90° ORIFICE CUPPER PIPE FITTING		3
	29	M-CMP-1600-460-3-60		COMPRESSOR		1
	30	MK190E-CEC		COMPRESSOR ELECTRICAL BOX - COVER		1
	31	M-FOP-1600		FAN OVERLOAD PROTECTOR		2
	32	MK260E-WHR22		WASHER 22x8,2x2,4		10
	33	MK260E-BLT850		BOLT M8x50		10
	34	MK190E-SGL1		SIGHT GLASS1		1
	35	MK190E-SPR		SEPERATOR		1
	36	MK190E-RCV		LIQUID RECEIVER		1
	37	M-OSO-1600		OIL SEPARATOR ORING		1
	38	M-RTA-5000-1		ROTOLOCK VALVE ADAPTOR FOR HEAT EXCHANGER		3
	39	MK260E-CTC1		CAPPILARY TUBE CONNECTION1		8
	40	M-OSP-1600		OIL SEPARATOR		1
	41	MK190E-SGL2		SIGHT GLASS2		1
	42	MK210E-ASF		ASTROFLEX		1
	43	MK260E-RSV		ROTOLOCK SERVICE VALVE		2
	44	M-CPF-6000		1/4 CUPPER PIPE FITTING		2
	45	MK190E-DRI		DRYER-DEHYDRATOR		1
	46	M-CLP-1200		CLAMP		1
	47	M-EXV-1200		EXPANSION VALVE		1
	48	MK260E-DSTK		DISTRIBUTOR CLAMP		1
	49	MK190E-DST		DISTRIBUTOR		1
	50	M-BYV-1200		BY-PASS VALVE		1
	51	MK190E-PCS		PIPING CONNECTION SHEET		1
	52	MK260E-PPC		PLASTIC PIPE CLAMP		1
	53	MK260E-DRM		DRAIN MANIFOLD		1
	54	MK260E-MRS		MANIFOLD REINFORCEMENT SHEET METAL		1
	55	MK260E-MBC1		MANIFOLD BLIND CAP1		3
	56	MK260E-EWF2		ELBOW FITTINGS2		1
	57	M-SLV-6000-24		SOLENOID VALVE		1
	58	M-MMV-6000		MEMBRAN VALVE		1
	59	M-DBV-6000		DRAIN BALL VALVE		3
	60	MK260E-T14		T 1/4"		1
	61	MK260E-FTS		FLAT FITTINGS		1
	62	MK260E-T12		T 1/2"		1
	63	MK190E-ELB-US		ELECTRICAL BOX		1
	64	MK190E-ELP		ELECTRICAL PANEL		1
	65	MK260E-DRS-NPT		DRAIN SLEEVE		1
	66	MK260E-SCF		SWITCH CONNECTION FITTING		3
	67	MK260E-DLK		DOOR LOCK		3
	68	MK260E-HNG		HINGE		3
	69	MK260E-LPS		LOW PRESSURE SWICH		1
	70	M-HPS-0200		HIGH PRESSURE SWITCH		1
	71	M-FNS-0200		FAN ON/OFF SWITCH		1
	72	M-MMM-6000		MEMBRANE		1
	73	N/A		N/A		-
	74	M-FHL-6000		LOW VOLTAGE FUSE HOLDER		1
	75	MK210E-RTA1		ROTOLOCK ADAPTOR1		1
	76	M-COP-1600		COMPRESSOR OVERLOAD PROTECTION		1
	77	M-PWC-2400		POWER CONNECTOR		3
	78	M-CNT-MP		FAN CONTACTOR		1
	79	M-CNT-1600		COMPRESSOR CONTACTOR		1
	80	M-TRF-1600		TRANSFORMER		1
	81	M-PPR-6000		PHASE PROTECTION RELAY		1
	82	M-FHH-6000		HIGH VOLTAGE FUSE HOLDER		4
	83	MK190E-CAL1		CABINET LEG1		3
	84	MK190E-CAL2		CABINET LEG2		1
	85	MK260E-PCP-ESD3		PLASTIC CONTROL PANEL		1
	86	MK260E-DCC-24		ADVANCED DIGITAL CONTROLLER		1
	87	MK260E-MSW		MAIN SWITCH		1
	88	MK190E-CFB		CABINET FRONT BOTTOM		1
	89	MK190E-CFT		CABINET FRONT TOP		1
	90	MK190E-CST		CABINET SIDE TOP		4
	91	MK190E-CSB		CABINET SIDE BOTTOM		2
	92	MK190E-CRT-US		CABINET REAR TOP		1
	93	MK190E-CSB1		CABINET REAR BOTTOM1		1
	94	MK190E-CSB2-US		CABINET SIDE BOTTOM2		1
	95	M-CHN-6000		CABINET HANDLE (NEW)		10
	96	MK190E-CRS		CABINET REAR SIDE BOTTOM		1
	97	MK190E-CPS		CABINET POST SECONDARY SIDE		2
	98	MK190E-CAT		CABINET TOP		1
	99	M-FAS-6000		CABINET FASTENER		14
	100	MK190E-RMS		REMOVABLE SHIELD		4
	101	MK260E-LPG		LOW PRESSURE GAUGE		1
	102	MK260E-HPG		HIGH PRESSURE GAUGE		1

8.1 - ED & Spare Part List

PDRCF4602000 / EDRCF4602000

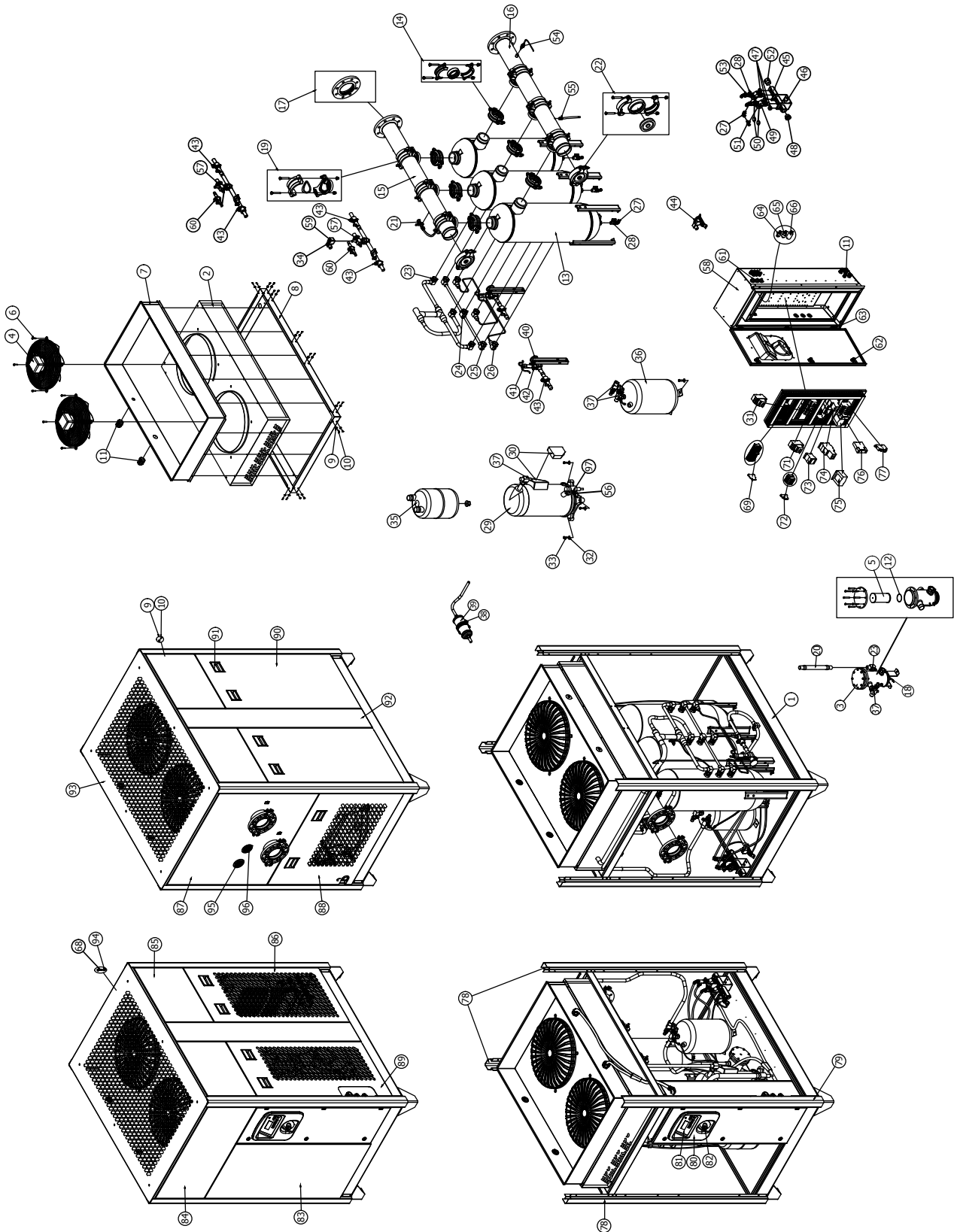

8.1 - ED & Spare Part List
PDRCF4602000 / EDRCF4602000

PART LIST						
DWG SIZE	ITEM NO.	PART NO		SPARE PART CODE	REV	QTY
	01	MK210E-CAB		CABINET BASE		1
	02	MK210E-CON		CONDANSER		1
	03	M-OSP-2400		OIL SEPARATOR		1
	04	M-FMT-6000-460-3-60		FAN MOTOR		2
	05	M-OSE-2400		OIL SEPARATOR ELEMENT		1
	06	MK260E-BLT830		BOLT M8x30		8
	07	MK210E-FPRT		FAN PROTECTOR		1
	08	MK210E-CRP		CONDENSER REINFORCEMENT PLATE		1
	09	M-NUT-6000		CAGE NUT M6		58
	10	MK260E-BLT630		BOLT M6x30		58
	11	M-CCP-6000		CONDUIT FOR CONTROL PANEL		5
	12	M-OSO-2400		OIL SEPARATOR ORING		1
	13	MK260E-EXC		HEAT EXCHANGER		3
	14	MK260E-CPG1		COUPLING CLAMP 1		6
	15	MK210E-CLLT		COLLECTOR TOP		1
	16	MK210E-CLLB		COLLECTOR BOTTOM		1
	17	MK210E-CPG2-UL		COUPLING CLAMP 2		2
	18	M-CPF-6000-90		1/4 90° ORIFICE CUPPER PIPE FITTING		3
	19	MK210E-CPG3		COUPLING CLAMP 3		6
	20	MK210E-ASF		ASTROFLEX		1
	21	MK260E-BLV		BALL VALVE		1
	22	MK210E-CPG4		COUPLING CLAMP 4		2
	23	M-RTA-5000-1		ROTOLOCK VALVE ADAPTOR FOR HEAT EXCHANGER		4
	24	M-RTA-5000-T-2		ROTOLOCK VALVE "T"ADAPTOR FOR HEAT EXCHANGER		1
	25	M-RTA-5000-2		ROTOLOCK VALVE ADAPTOR FOR HEAT EXCHANGER		2
	26	MK260E-RTA4		ROTOLOCK ADAPTOR4		3
	27	MK260E-EWF1		ELBOW FITTINGS1		10
	28	M-DBV-6000		DRAIN BALL VALVE		5
	29	SEE REF TABLE		COMPRESSOR		1
	30	MK210E-CEC		COMPRESSOR ELECTRICAL BOX - COVER		1
	31	M-COP-0325		FAN OVERLOAD PROTECTOR		2
	32	MK260E-WHR22		WASHER 22x8,2x2,4		10
	33	MK260E-BLT850		BOLT M8x50		10
	34	N/A		N/A		-
	35	MK210E-SPR		SEPERATOR		1
	36	MK210E-RCV		LIQUID RECEIVER		1
	37	MK160E-RTA2		ROTOLOCK ADAPTOR2		4
	38	M-CLP-1200		CLAMP		1
	39	MK210E-DRI		DRYER-DEHYDRATOR		1
	40	M-EXV-2400		EXPANSION VALVE		1
	41	MK210E-DST		DISTRIBUTOR		1
	42	MK260E-DSTK		DISTRIBUTOR CLAMP		1
	43	MK260E-GBV		BALL VALVE		5
	44	M-SLV-6000-24		SOLENOID VALVE		1
	45	MK260E-DRM		DRAIN MANIFOLD		1
	46	MK260E-MRS		MANIFOLD REINFORCEMENT SHEET METAL		1
	47	MK260E-MBC1		MANIFOLD BLIND CAP1		3
	48	MK260E-MBC2		MANIFOLD BLIND CAP2		1
	49	M-MMV-6000		MEMBRAN VALVE		2
	50	M-MMM-6000		MEMBRANE		2
	51	MK260E-T14		ELBOW FITTINGS T 1/4"		1
	52	MK260E-DRS-NPT		DRAIN SLEEVE		1
	53	MK260E-MAS		MANSON 1/2"		2
	54	M-SCF-6000		SENSOR CONNECTION FITTING		1
	55	MK260E-FTS		FLAT FITTINGS		1
	56	M-CPF-6000-O		1/4 90° ORIFICE CUPPER PIPE FITTING		1
	57	M-BYV-1600		BY PASS VALVE		1
	58	MK210E-ELB-US		ELECTRICAL BOX		1
	59	MK210E-BSLV		BY BASS SOLENOID VALVE		1
	60	MK260E-GBV-1/4		BALL VALVE 1/4		1
	61	MK260E-SCF		SWITCH CONNECTION FITTING		3
	62	MK260E-DLK		DOOR LOCK		3
	63	MK260E-HNG		HINGE		3
	64	MK260E-LPS		LOW PRESSURE SWITCH		1
	65	M-HPS-0200		HIGH PRESSURE SWITCH		1
	66	M-FNS-0200		FAN ON/OFF SWITCH		1
	67	N/A		N/A		-
	68	M-STU-6000		CABINET STUD AND NUT		14
	69	M-FHL-6000		LOW VOLTAGE FUSE HOLDER		1
	70	N/A		N/A		-
	71	M-COP-3000		COMPRESSOR OVERLOAD PROTECTION		1
	72	M-PWC-2400		POWER CONNECTOR		3
	73	M-CNT-MP		FAN CONTACTOR		2
	74	M-CNT-2400		COMPRESSOR CONTACTOR		1
	75	M-TRF-1600		TRANSFORMER		1
	76	M-PPR-6000		PHASE PROTECTION RELAY		1
	77	M-FHH-6000		HIGH VOLTAGE FUSE HOLDER		4
	78	MK210E-CAL1		CABINET LEG1		3
	79	MK210E-CAL2		CABINET LEG2		1
	80	MK260E-PCP-ESD3		PLASTIC CONTROL PANEL		1
	81	MK260E-DCC-24		ADVANCED DIGITAL CONTROLLER		1
	82	MK260E-MSW		MAIN SWITCH		1
	83	MK210E-CFB		CABINET FRONT BOTTOM		1
	84	MK210E-CFT		CABINET FRONT TOP		1
	85	MK210E-CST		CABINET SIDE TOP		4
	86	MK210E-CSB		CABINET SIDE BOTTOM		1
	87	MK210E-CRT-US		CABINET REAR TOP		1
	88	MK210E-CSB1		CABINET REAR BOTTOM1		1
	89	MK210E-CSB2-US		CABINET SIDE BOTTOM2		1
	90	MK210E-CRS		CABINET REAR SIDE BOTTOM		2
	91	M-CHN-6000		CABINET HANDLE		10
	92	MK210E-CPS		CABINET POST SECONDARY SIDE		2
	93	MK190E-CAT		CABINET TOP		1
	94	M-FAS-6000		CABINET FASTENER		14
	95	MK260E-LPG		LOW PRESSURE GAUGE		1
	96	MK260E-HPG		HIGH PRESSURE GAUGE		1
	97	MK260E-RTA3		ROTOLOCK ADAPTOR3		1

9. COMPONENTS LOCATION

All main components located into dryer identified with labels as listed here under.

CAUTION: Due to manufacture design, some components out of the list are not installed into the dryer.

Electrical components:

Accessories :

A01:	Control circuit transformer
A02:	Power circuit transformer
A10:	ON warning light
A11:	OFF warning light
A20:	Drain solenoid valve
A30:	Crankcase heater
A31:	Electrical resistor
A40:	Electrical capacity
EV3	Digital Controller (Digi-Pro)
A50-3:	Energy saving device 3 (ESD3)

Relays :

K01:	Compressor motor relay
K10:	Fan motor relay
K20:	Drain timer or Bekomat (optional)
K30:	Temperature Controller

Switches :

S01:	Main switch
S02:	Start push button
S03:	Stop push button
S10:	Fan pressure control
S11:	High-low pressure security control
S12:	High pressure security control
S13:	Low pressure security control
S20:	Refrigerant temperature control
S21:	Air temperature control

Motors :

M01:	Refrigerant compressor motor
M10:	Fan motor

Thermal protections :

P01:	Refrigerant compressor thermal overload
P10:	Fan motor thermal overload

Fuses protections :

See complete identification into electrical sketch included in dryer

F--:	Transformer protection
F--:	Fan protection
F--:	Compressor relay protection
F--:	Transformer protection
F--:	Drain protection
F--:	Fan relay protection

Refrigerant components:

G01:	Liquid receiver
G02:	Refrigerant drier
G03:	Expansion valve
G04:	Liquid separator
G05:	Hot gas bypass valve
G06:	Refrigerant solenoid valve
G10:	Water cooled condenser
G11:	Water control valve
G20:	Refrigerant evaporating pressure gauge
G21:	Refrigerant evaporating temperature gauge

Compressed air components :

H01:	Air inlet prefilter
H11:	Drain filter
H12:	Pneumatic drain valve

Terminal boxes:

B01:	Main terminal box
B11:	Refrigerant unit terminal box
B12:	Free of potential terminal box

Problem	Possible Cause	Repair	Comments	
Dryer is switched on, indicator light is lit but the refrigerant compressor does not turn on.	The connection has inverted phases	Invert two phases	3-phase dryers are equipped with a phase controller to avoid the fans from turning in the opposite direction.	
	Refrigeration unit is not functioning	Check refrigeration compressor	Several factors can cause compressor failure. A qualified refrigeration technician needs to check all the electrical and refrigerant circuit and controls.	
	The refrigerant highpressure protection has tripped	The refrigerant safety high pressure switch has tripped.	In case of water cooled condensers, check the water control valve	The dryer is protected against excessively high refrigerant pressure. If the condenser efficiency has reduced, the switch will trip. Manually reset the switch.
		Excessive ambient temperature		
Dryer is switched on, but the refrigerant compressor does not turn on.	Excessive temperature on crankcase of compressor.	Allow time to compressor to cool down. Reason may be a possible incorrect adjustment of hot gas bypass valve or shortage of refrigerant	Compressor is protected against overly high temperatures of the crankcase by a thermal switch.	
	Excessive compressed air inlet temperature.	Be sure that dryer is working in temperatures lower than design conditions.	The dryer is designed for working in calculated conditions (see description in this manual). If conditions are exceeded, the dryer will be overflowed, dew point will go up and protecting devices can switch off.	
	Clogged condenser fins or clogged water condenser. Possible high crankcase temperature Possible loss of phase Possible low voltage causing overload trip Possible failed compressor	Clear fins or water condenser of all obstructions.	The clogged fins in the condenser will restrict the air passage and reduce the refrigeration capacity, causing high temperature in the evaporator. Same will occur if water condenser is clogged with mud or dirt. Air condenser and water condenser should be periodically checked and cleaned. Protect water circuit by an adapted filter.	
	Too much compressed air flow.	Check actual flow through the dryer.	This dryer is designed for a maximum air flow at design conditions. If too much air is pumped into the dryer, water removal capacity may not be sufficient, resulting in liquid carryover down stream. Check the rated output the air compressor.	
	Faulty electrical wiring	Inspect the circuit	The compressor-on light should be wired into the refrigerant compressor circuit. See wiring diagrams in this manual.	
	One electrical protection has tripped.	Reset the protection or replace the blown fuse.	The dryer is protected against high amp draw by fuse and/or overload relay that can trip in case of need. Reset or replace fuse once, but do not persist if it trips again, request assistance from a qualified refrigeration contractor.	
Dryer is switched on but fan is not running.	Fan has to run if refrigerant high pressure reaches upper set point.	Check that compressed air flows through the dryer. Check that fan blades are free to move. Check the fan pressure switch.	Fan operates automatically to keep refrigerant pressure below the maximum value. The fan can stop if pressure is under the recommended setting.	
When compressor starts, it vibrates a lot and makes mechanical noise.	Compressor is slugging liquid refrigerant at start up.	Be sure the pre-heating period of at least 2 hours is respected	Refrigerant may move between receivers when refrigerant compressor is stopped and not heated, especially if stopped for a long time. This migration may cause liquid shock (slugging) in valves specially on large dryers containing more refrigerant	

Problem	Possible Cause	Repair	Comments
Water in system	Compressed Air Inlet and outlet connections are reversed.	Check inlet and outlet connections.	This dryer is designed for air flow in one direction only. Inlet and outlet directions are identified on the dryer.
	Drain system is clogged or inoperative.	Restore a free flow of water condensate. Check water evacuation.	Drain system is timed solenoid valve, pneumatically assisted which has to be adjusted in accordance with values listed in this manual. The Solenoid valve includes a strainer that has to be periodically checked and cleaned. Membranes of pneumatically assisted drain have to be checked or replaced every 6 months.
	Bypass system is open	Check the valves	Important: Bypass piping should be installed around the dryer so the dryer can be isolated for service without shutting down the air supply. During dryer operation, valves must be set so all air goes into the system. Check tightness of the bypass system.
	Free moisture remains in pipe lines.	Blow out the system	Before the dryer is first started all free moisture should be blown out of the system.
	Excessive air flow	Check actual flow through the dryer.	This dryer is designed for a maximum air flow. If too much air is pumped into the dryer, water removal capacity may not be sufficient, resulting in liquid carry over downstream. Check the rated flow of the air compressor.
	Excessive free moisture	Check the separator and drain system and compressor after cooler ahead of the dryer.	In some system there may be an accumulation of free moisture in the line ahead of the dryer. If this moisture is pumped into the dryer intermittently, the water removal capacity may not be sufficient. A water separator should be installed in the line before the dryer.
	Excessive compressed air inlet temperature.	Be sure that dryer is working lower than design conditions	The dryer is designed to work for calculated design conditions. Should the conditions be exceeded, the dryer will be overflowed, dew point will go up and protecting devices can switch off.
	Clogged condenser fins	Clear fins of all obstructions	The clogged fins in the condenser will restrict air passage and reduce refrigerant capacity causing water downstream. Fins should be periodically checked and cleaned.
	Shortage of refrigerant	Fix the leak and add a charge of refrigerant.	Loss of refrigerant will cause improper functioning. A qualified, refrigeration specialist should perform the necessary repairs, or factory should be contacted if the unit is in warranty.
	Refrigeration system is not functioning	Check to be certain refrigerant compressor is running	To check if the compressor is running, check compressor-on light. It is possible for the fan to be operating but not the compressor. Compressor not running can be caused by several factors. A qualified refrigeration technician should check all refrigerant and electrical controls
	Excessive pressure dew point	Readjust refrigerant evaporating pressure	The refrigerant pressure adjustment should be done by a qualified refrigeration engineer. This is a very sensitive device and incorrect settings may create other failures.
High pressure drop	Excessive compressed air flow or too low air inlet pressure.	Check actual pressure and flow through the dryer.	This dryer is designed for a maximum air flow. If too much air is pumped into the dryer, water removal capacity may not be sufficient, resulting in liquid carry-over downstream. Check the rated flow of the air compressor.
	Freeze up	Check that compressor room ambient,	Frosting of the lines is an indication that controls are set too low. The following should be done by an experienced refrigeration technician.
Fan switch could have failed in closed position keeping fan on.		Controls may be adjusted in the fields by means of the hot gas bypass valve. This is to be done by a qualified refrigerant technician.	
The unit will not run or cycles off and on.	Clogged heat exchanger	Clean heat exchanger with reverse air flow.	Dryer are supposed to be used with compressed air free of any aggressive contaminants. Some contamination may require extra maintenance of the heat exchanger.
	Line disconnect switch is open.	Close the start or disconnect switch.	If the dryer is not operating, check the disconnect switch or circuit breaker to be certain it is on.
	Fuse or breaker is open	Replace fuse or reset breaker.	The fuse to the power line should be checked and replaced if needed. Never replace a burnt fuse with an oversized fuse.
	Faulty refrigerant compressor or controls.	Determine the cause and make correction	Failure of compressor to run may be caused by several factors. A qualified refrigeration specialist should check all electrical and refrigeration controls, or factory should be contacted if unit is in warranty.
	Excessive compressed air inlet temperature.	Design conditions and correction factors are described in this manual. Be sure that dryer is working in ambient temperatures below design conditions.	The dryer is designed for working into calculated design conditions. Should the conditions be exceeded, the dryer will be overflowed, dew point will go up and protecting devices may trip.

Problem	Possible Cause	Repair	Comments
The unit will not run or cycles off and on.	Excessive ambient temperature	Designed conditions and correction factors are described in dryer . Be sure that dryer is working lower than design conditions.	A high ambient temperature may cause the refrigerant system to operate at higher than normal pressures. Results will be a higher than normal evaporator temperature. Important: there should be adequate air circulation around the dryer, and proper ventilation in the equipment room should guarantee a low enough ambient temperature.
	Clogged condenser fins	Clear fins of all obstructions.	The clogged fins in the condenser will restrict the air passage and reduce the refrigeration capacity, causing high temperature in the evaporator. Fins should be periodically checked and cleaned.
	Low refrigerant level	Fix the leak and add a charge of refrigerant.	Loss of refrigerant will cause improper functioning. Dryers are equipped with a temperature switch which maintains the amount of refrigerant to maintain proper cooling of the compressor. A shortage of refrigerant may cause suction line to become very hot, causing the temperature switch to trip. A qualified refrigeration specialist should perform the necessary repairs.
Error sign occurs on digital temperature control device	The dew point is too low or too high	Check refrigerant gas and make sure that the working conditions are within the correct range.	If there is not enough refrigerant gas or if the working temperature and inlet temperatures are very high, the dew point will increase.
Drain Failure	Back pressure or reduction of drain port.	Back First of all replace the drain / drains. Open drain to atmosphere (no back pressure) - if hose / pipe is used to carry the drain somewhere else; keep or enlarge the diameter.	Max drain hose length after the dryer must not exceed 30 feet.
			Max drain hose height from the dryer must not exceed 9 feet.
			The drain port size should not be reduced.
			There should not be any fitting that may cause pressure drop such as valves, elbow, tees, etc. on the drain connection.
			Drain should be at atmospheric pressure at all times. Any back pressure will result in failure and malfunction.

Refrigerated Dryer (PDRCF / EDRCF) WARRANTY POLICY

When used under the conditions recommended the heat exchanger will be warranted for Ten (10) years parts. This warranty is limited to the replacement of the heat exchangers, some restrictions as outlined below concerning misuse, abuse or accident. The standard equipment external float drain and automatic drain carry a 2-year parts warranty along with all other components.

This warranty will apply to equipment installed, operated and maintained in accordance with the procedures and recommendations as outlined in the owner's manual published by Airbase During the life of this warranty, Airbase will repair or replace (at Airbase Industries discretion) any defective part or assembly free of charge if such defect occurred in normal service and was not due to apparent misuse, abuse or accident. Customer is responsible for shipping charges. Labor is covered for 1 year.

Airbase Industries is not responsible for any downtime, nor any damages incurred during installation. Any warranty service performed in the field must be authorized by Airbase Unauthorized service voids the warranty and any resulting charges will not be paid by Airbase

Airbase makes no other warranties or guarantees, expressed or implied. Airbase assumes no liability for indirect or consequential damages. This Warranty is not transferable.