



Wonderlanes®

ATV RACER™

12V BATTERY POWERED

12V Battery Powered

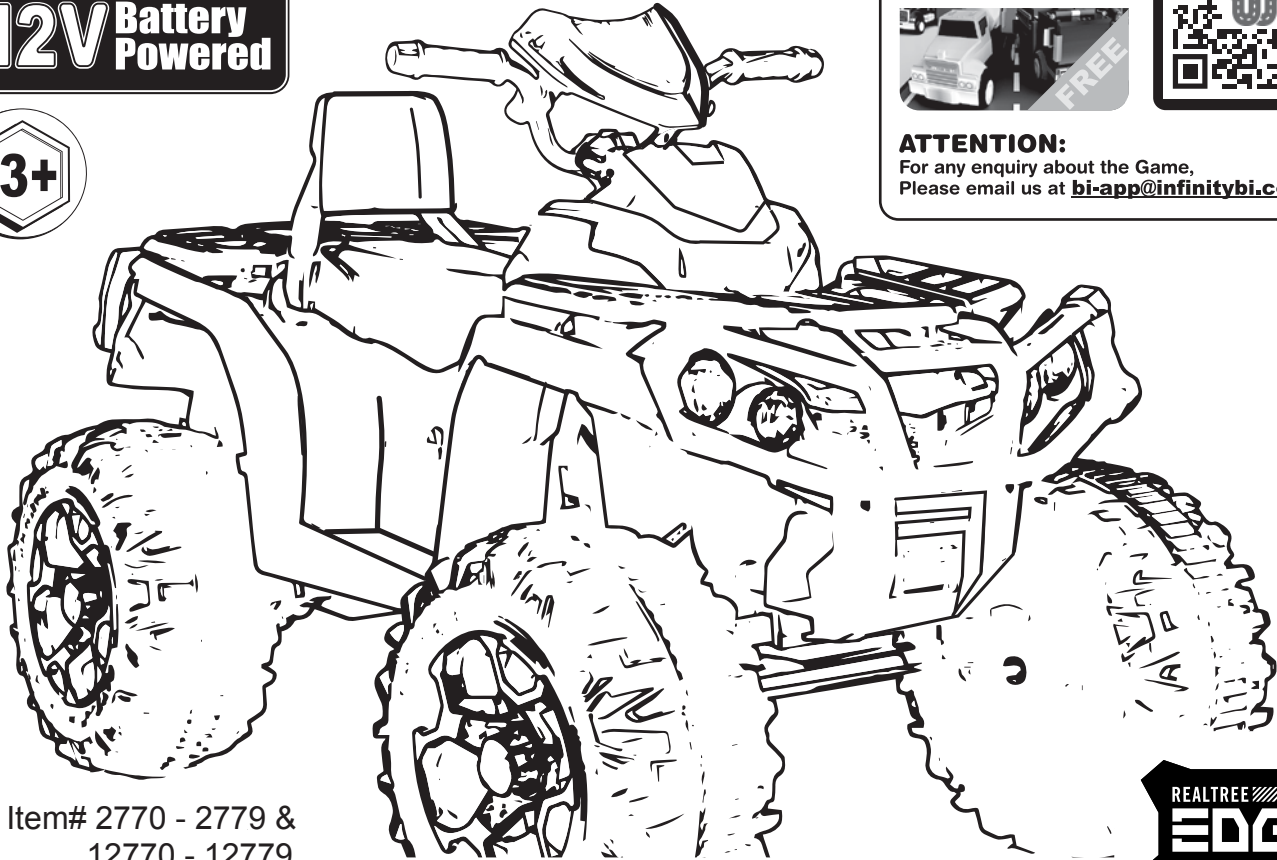

Item# 2770 - 2779 &
12770 - 12779



Scan me for Free Game!



VER 1.0

ATTENTION:

For any enquiry about the Game,
Please email us at bi-app@infinitybi.com



REALTREE®



BATTERY POWERED RIDE-ON OWNERS MANUAL

Read and understand this entire manual before using!

Please keep this manual for future reference as it contains important information.

**DO NOT RETURN TO STORE
WE ARE HERE TO HELP**

For Customer Service, information, parts order,
please Email or Call our Trained Technical Staff.

**BEYOND INFINITY LIMITED
TOLL FREE: 1-888-458-3288
E-mail: 2service@infinitybi.com**

www.wonderlanestoys.com
www.infinitybi.com



WARNING:

- **CHOKING HAZARD!** Not suitable for children under 3 years.
- **ADULT ASSEMBLY REQUIRED.**

About Your New Vehicle

The owner's manual contains assembly, use and maintenance instructions. The vehicle must be assembled by an adult who has read and understands the instructions in this manual. Keep the packaging away from children and dispose of all packaging before use. Keep instructions for future reference.

Specification

Suitable age: 3+ years
Battery: 12V x1
Charge time: 8-12 hours
Charge: Input: 100V - 120V~50/60Hz
0.3A
Output: DC12V1000mA
Weight Limit: 88 lbs
Size of car: 44.5 x 26.38 x 32"
Speed: 2.5 - 5.0mph



PRODUCT FEATURES:

- Officially Realtree Licensed
- Power Switch
- Forward and Reverse Gears
- Real Working Radio
- MP3 Line-in Jack
- Working Head Lights
- Working Tail Lights
- Electronic Sound Effects
- 12V Rechargeable Battery

DO NOT RETURN TO STORE WE ARE HERE TO HELP

For Customer Service, information, parts order,
please Email or Call our Trained Technical Staff.

BEYOND INFINITY LIMITED

TOLL FREE: 1-888-458-3288

E-mail: 2service@infinitybi.com

www.wonderlanestoy.com

www.infinitybi.com

Parts List

NO.	PART NAME	Q'TY (PCS)
1	Vehicle body	1
2	Gear box	2
3	Driving wheel	2
4	Φ12 washer	6
5	Lock nut	5
6	Hubcap	4
7	Front wheel	2
8	Front axle	1
9	Φ4x12 screw	8
10	Rear axle	1
11	Handle bar	1
12	M5x35 machine screw	1
13	Φ5 nut	1
14	Seat	1
15	Φ4x10 screw	1
16	Back rest	1
17	Spanner	2
18	Charger	1
19	Φ10 washer	1

Assembly tools required:

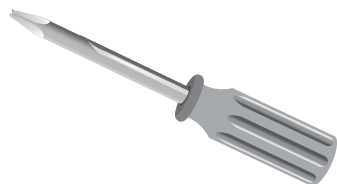

Screwdriver (not included)

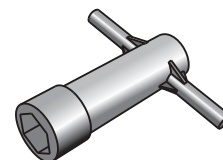

X 2

Spanner

Parts Diagram

HINT: Some parts shown are assembled on both sides of vehicle

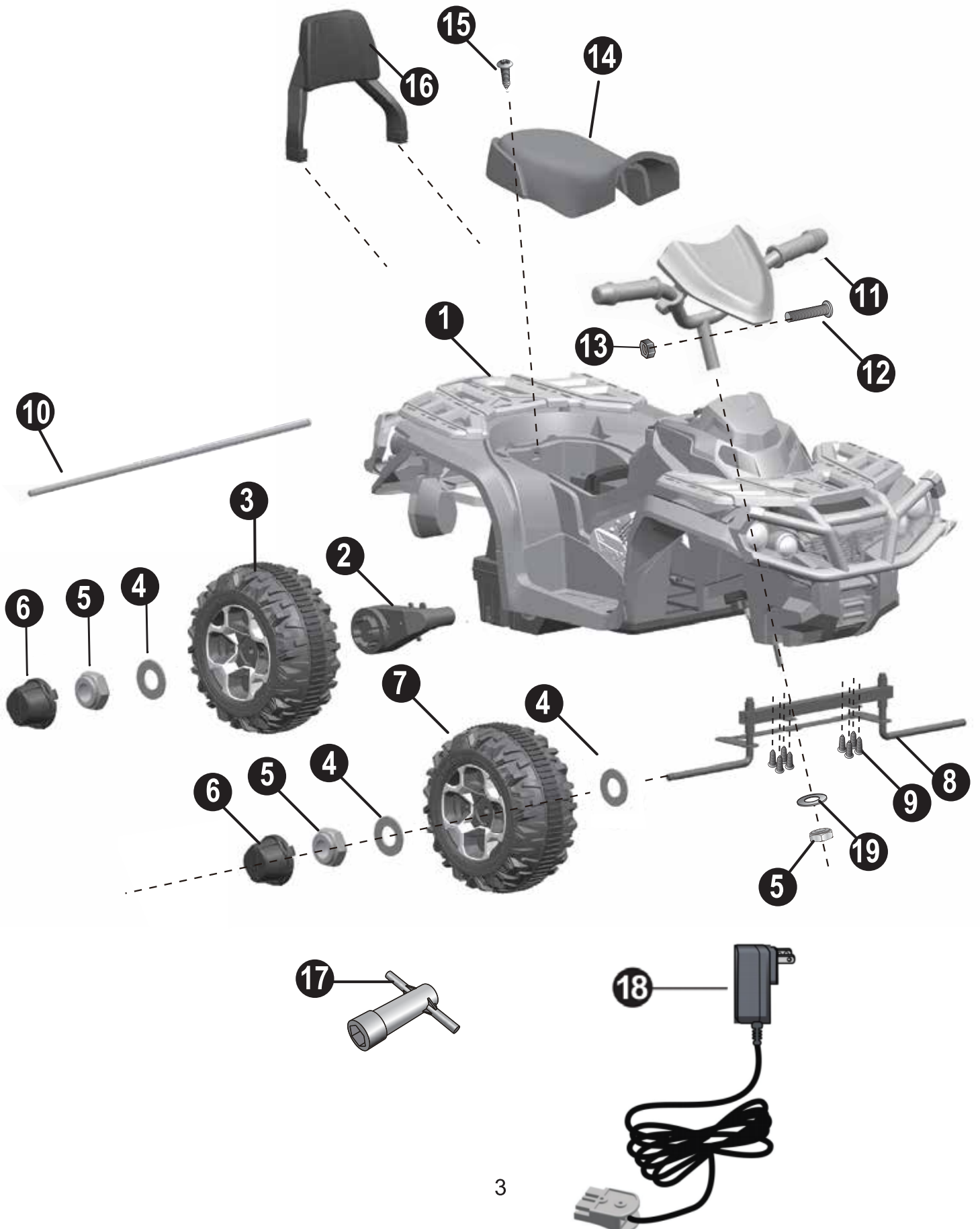

Safety

WARNING!

- **CHOKING HAZARD** - Small parts. Not suitable for children under 36 months. The product contains small parts, keep children away when assembling.
- **ADULT ASSEMBLY REQUIRED.**
- Always remove protective material and poly bags and dispose before assembly.



PREVENT INJURIES AND DEATHS:

- **NEVER LEAVE CHILD UNATTENDED. ADULT DIRECT SUPERVISION IS REQUIRED.** Always keep child in view when child is in vehicle.
- This toy should be used with caution since skill is required to avoid falls or collisions causing injury to the user or third parties.
- Protective equipment should be worn.
- Not to be used in traffic.
- This toy is unsuitable for children under 36 months due to its maximum speed; Maximum user weight is 88lbs.
- This toy has no brake.

BATTERY INFORMATION

- Non-rechargeable batteries are not to be recharged.
- Rechargeable batteries are to be removed from the toy before being charged.
- Rechargeable batteries are only to be charged under adult supervision.
- Different types of batteries or new and used batteries are not to be mixed.
- Batteries are to be inserted with the correct polarity.
- Exhausted batteries are to be removed from the toy.
- The supply terminals are not to be short-circuited.

Assembly

A) Front Axle Assembly

Front bottom view

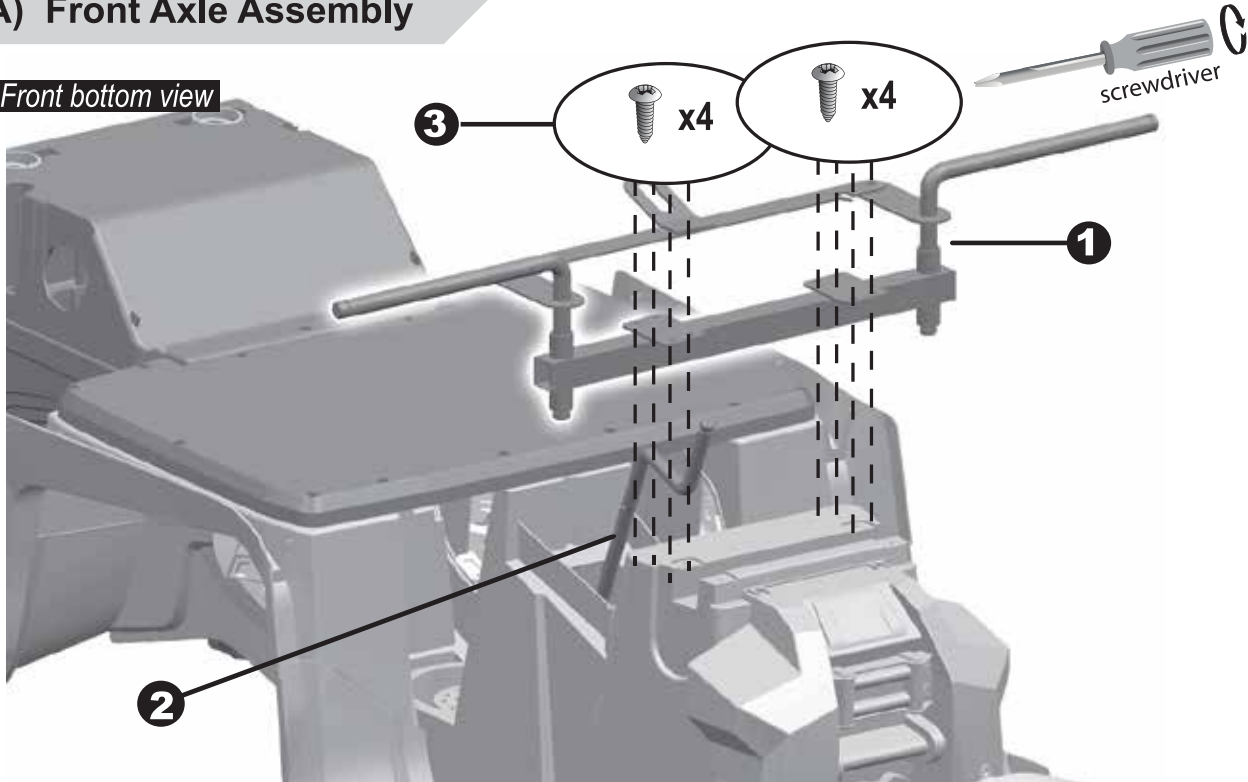

- 1 Turn the vehicle body downside up. Fit the front axle to the vehicle body.
- 2 Ensure the bent end of the steering column passes through the hole on the front axle linkage. Make sure the screws are tightened before moving to next step.
- 3 Insert eight screws through the front axle and into the vehicle body, tighten with a screwdriver.

Front bottom view

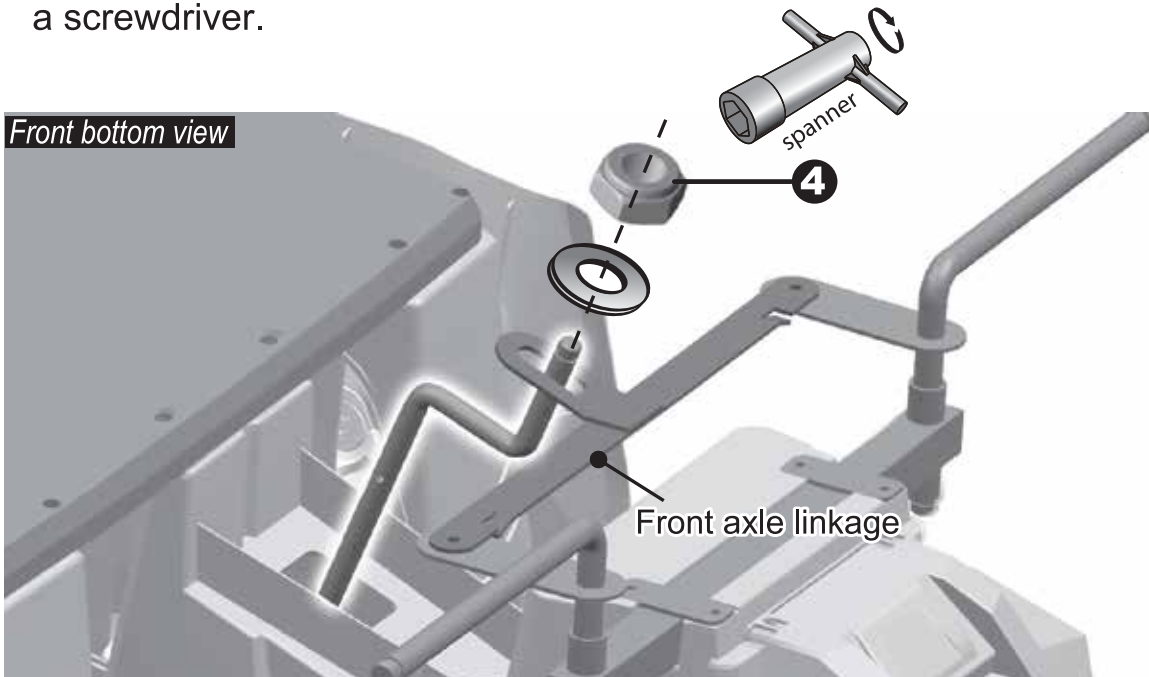

- 4 Slide a $\Phi 10$ washer and tighten a locknut to the bent end of the steering column with a spanner.

Assembly

B) Front Wheel Assembly

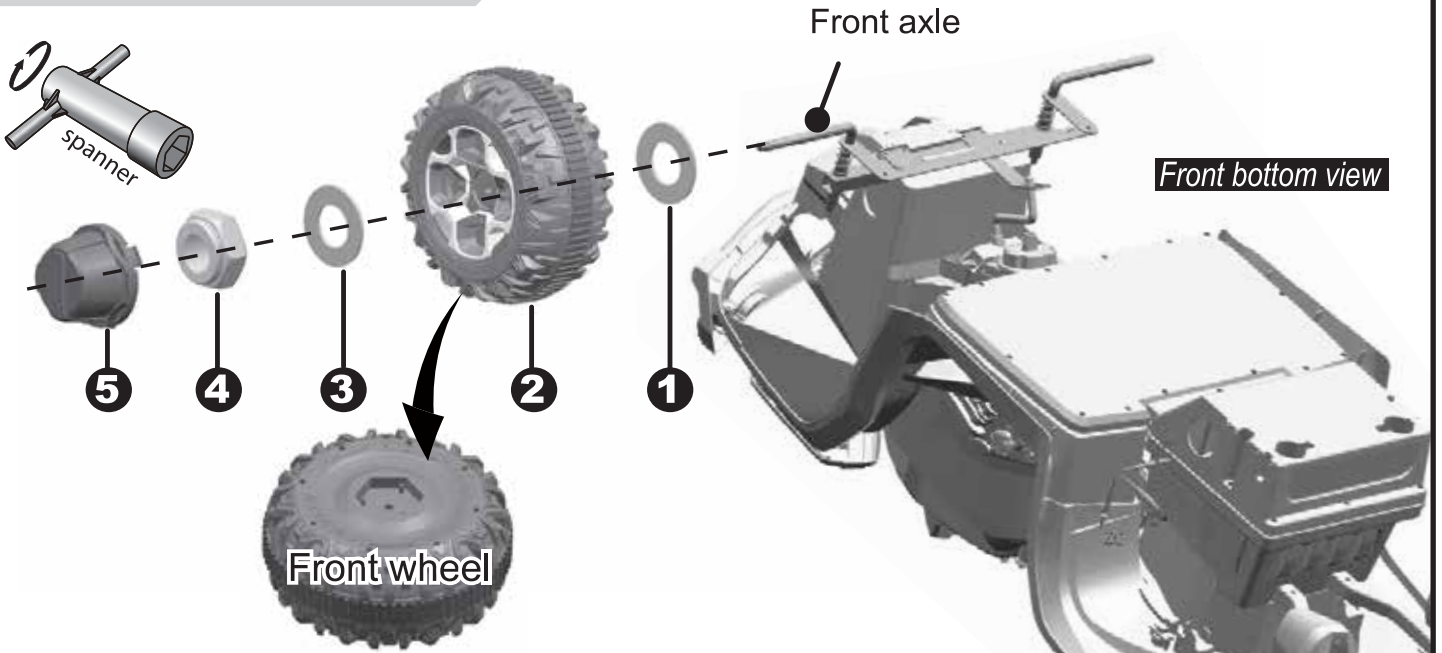

- 1 Slide a $\Phi 12$ washer onto the front axle.
- 2 Slide a front wheel onto the front axle.
- 3 Slide a $\Phi 12$ washer onto the front axle.
- 4 Tighten a lock nut to the end of the front axle with a spanner
- 5 "Snap" the hubcap to the wheel.

Repeat the above procedure to the other side.

C) Rear Axle Assembly

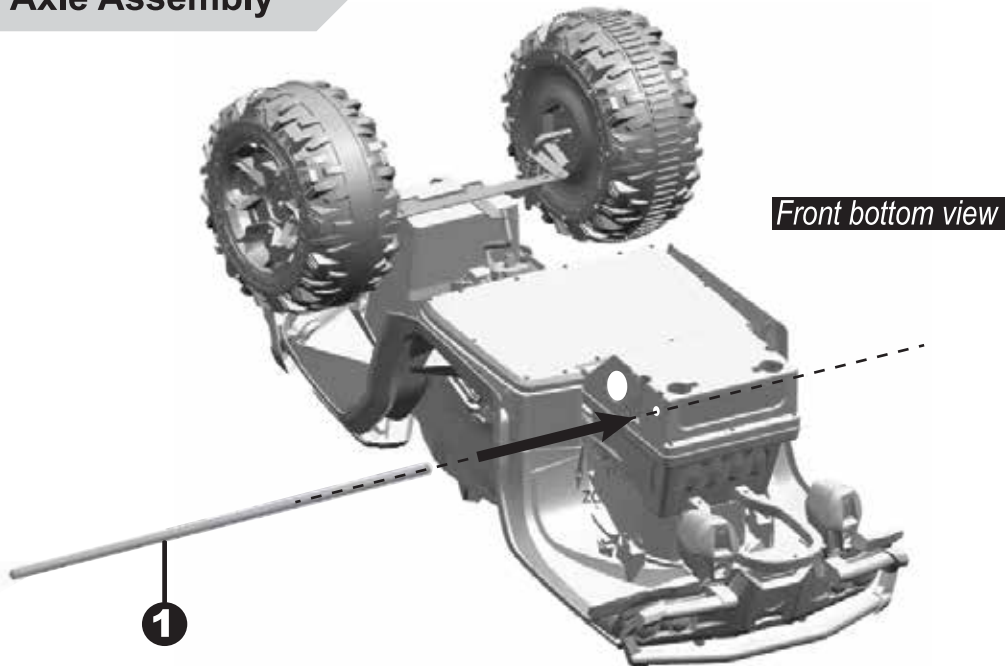

- 1 Insert the rear axle into the hole on the vehicle.;

Assembly

D) Rear Wheel Assembly

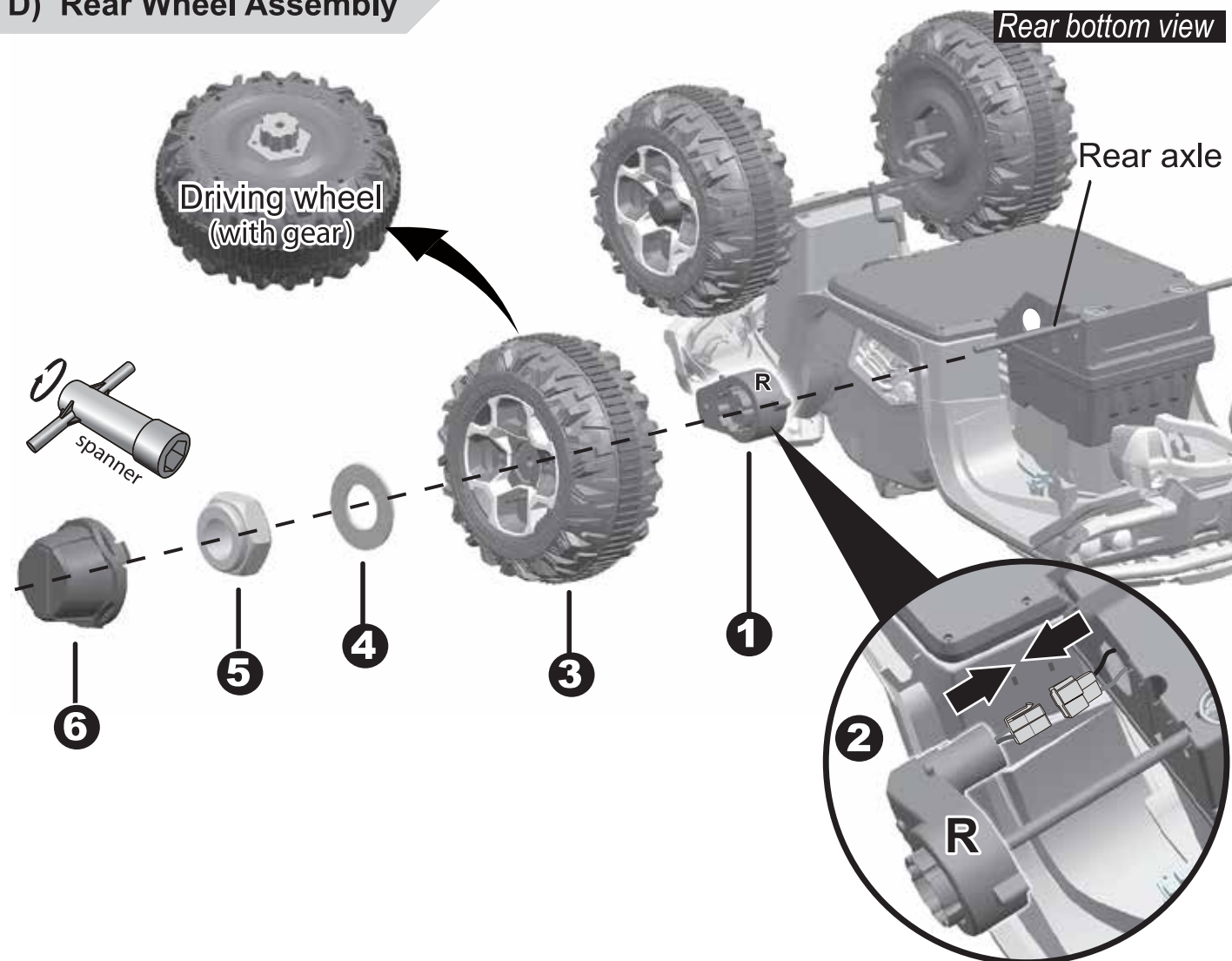

- 1** Slide a gear box onto the rear axle. "R" labeled gear box should be fit to the "Right" side of vehicle body, "L" labeled gear box should be fit to the Left side of vehicle body
- 2** Plug the connector on the gear box into the connector on the vehicle.
- 3** Slide a driving wheel onto the rear axle.
- 4** Slide a $\Phi 12$ washer onto the rear axle.
- 5** Tighten a lock nut to the end of the rear axle with a spanner.

Repeat the above procedure to the other side.

HINT: An extra spanner has been provided to hold the lock nut on the other side of the rear axle while tightening the lock nut on the other side.

- 6** "Snap" the hubcap to the wheel.

Turn the vehicle body upright.

Assembly

E) Steering Handle Assembly

- 1** Fit the handle bar tube to the end of the steering column.
- 2** Align the holes on each side of handle bar with the holes at the end of the steering column.
- 3** Fasten a nut on the opposite end of the screw to secure the steering wheel to the steering column.

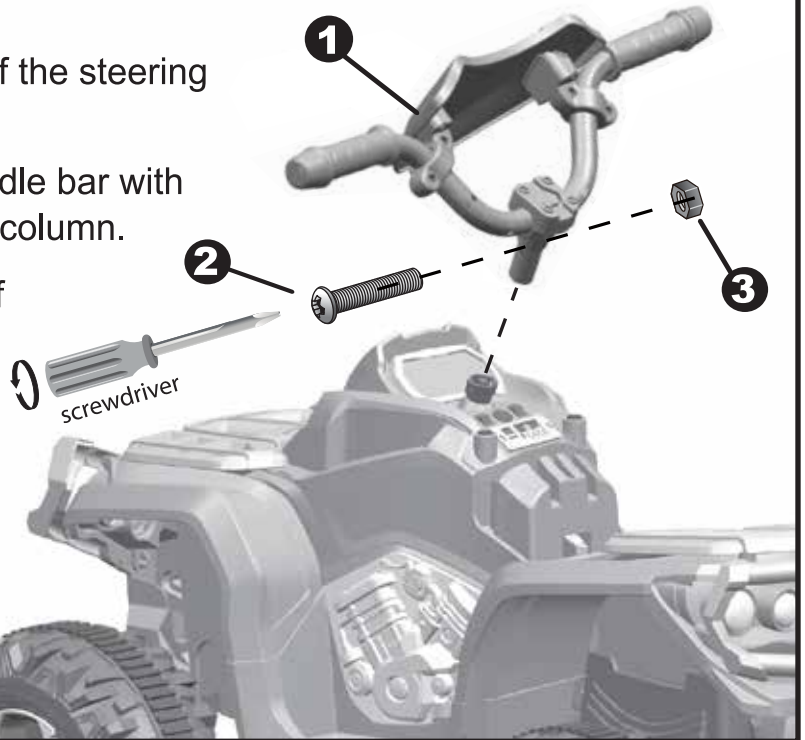

F) Connecting Battery

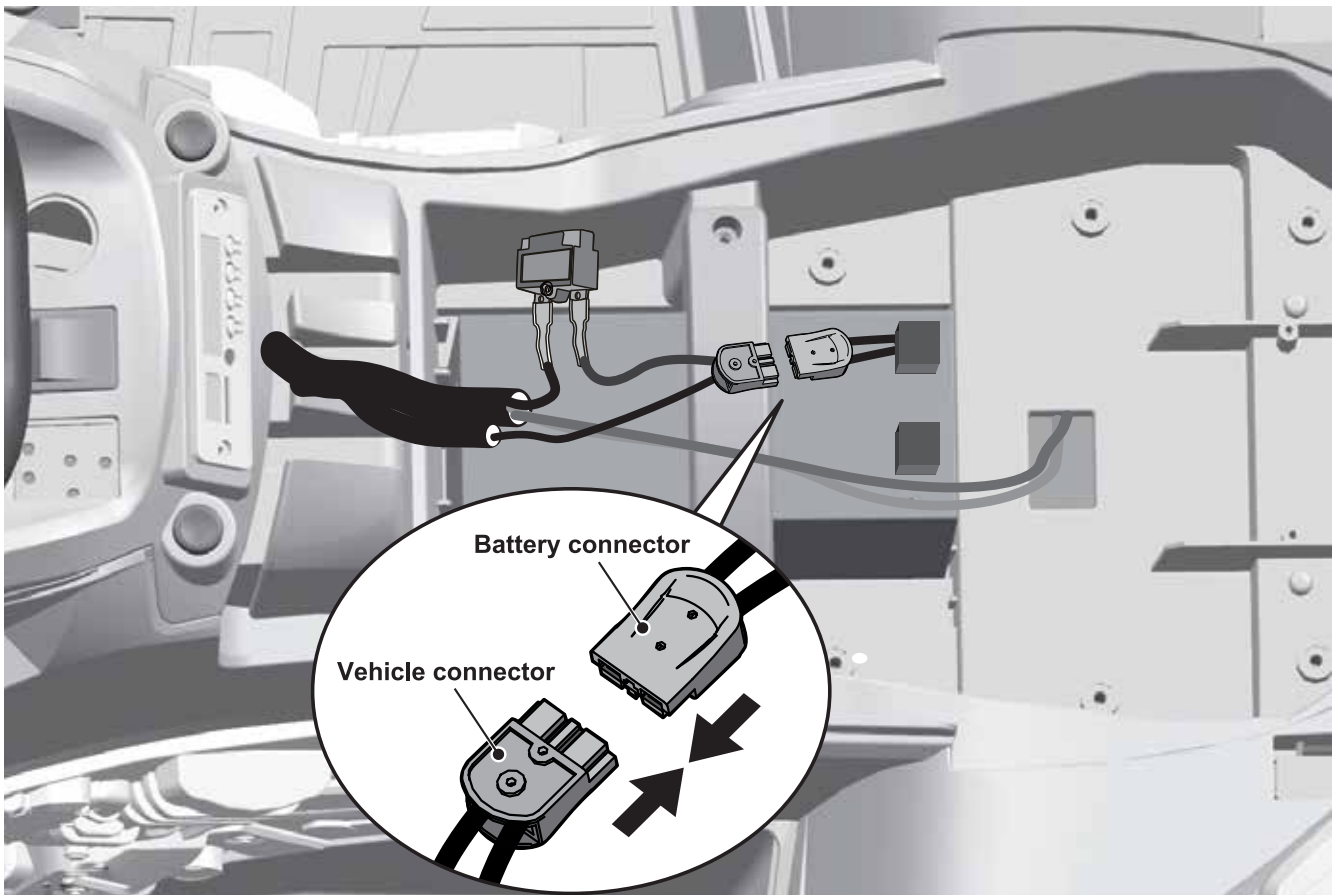

- 1** Plug the vehicle connector into the battery connector with correct orientation.

Assembly

G) Seat Assembly

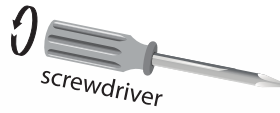

- 1 Fit the seat to the vehicle body.
- 2 Tighten a $\Phi 4 \times 10$ screw to secure the seat.

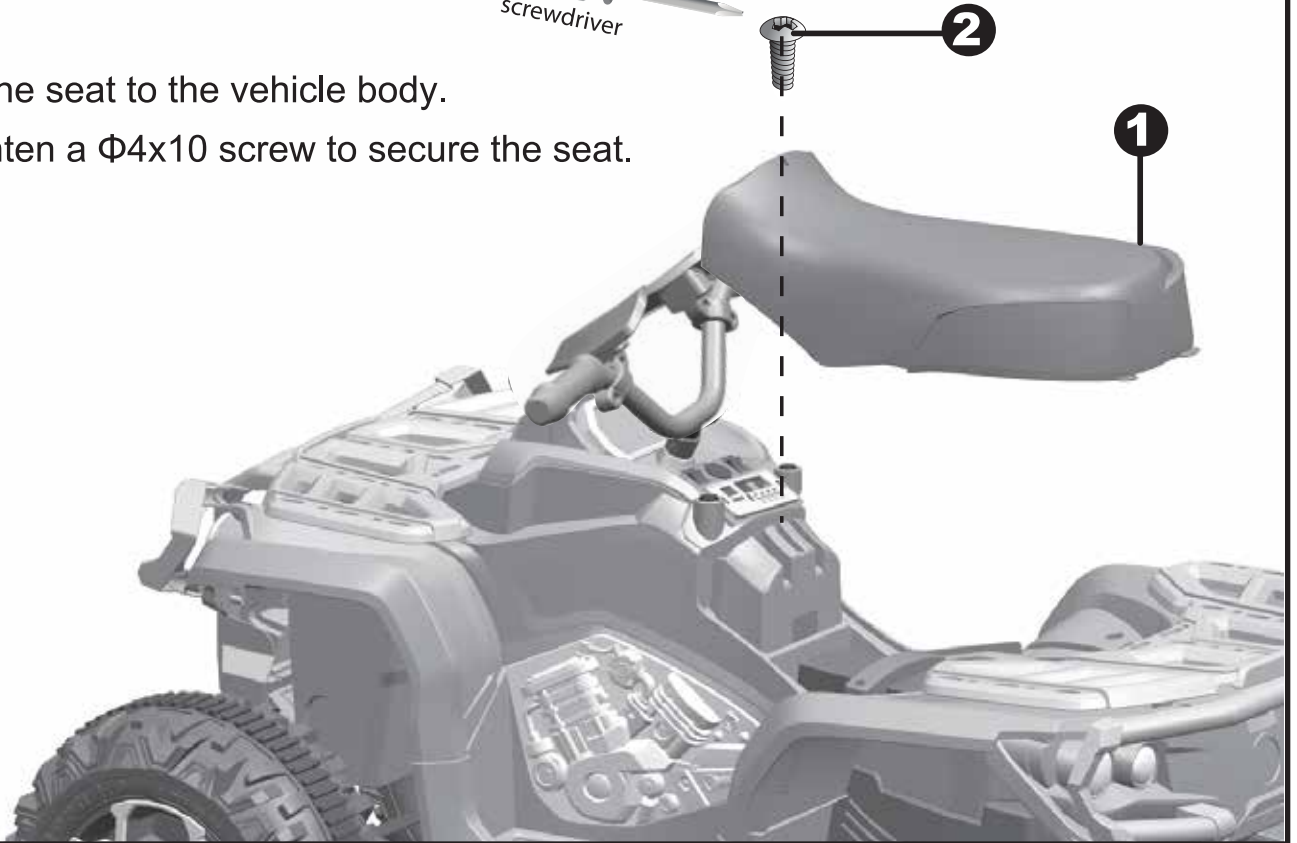

H) Back Rest Assembly

- 1 Insert the tabs on the back rest into the slots on the rear of the vehicle. Push it until you hear it "click" into place.



Use Your New Ride-on

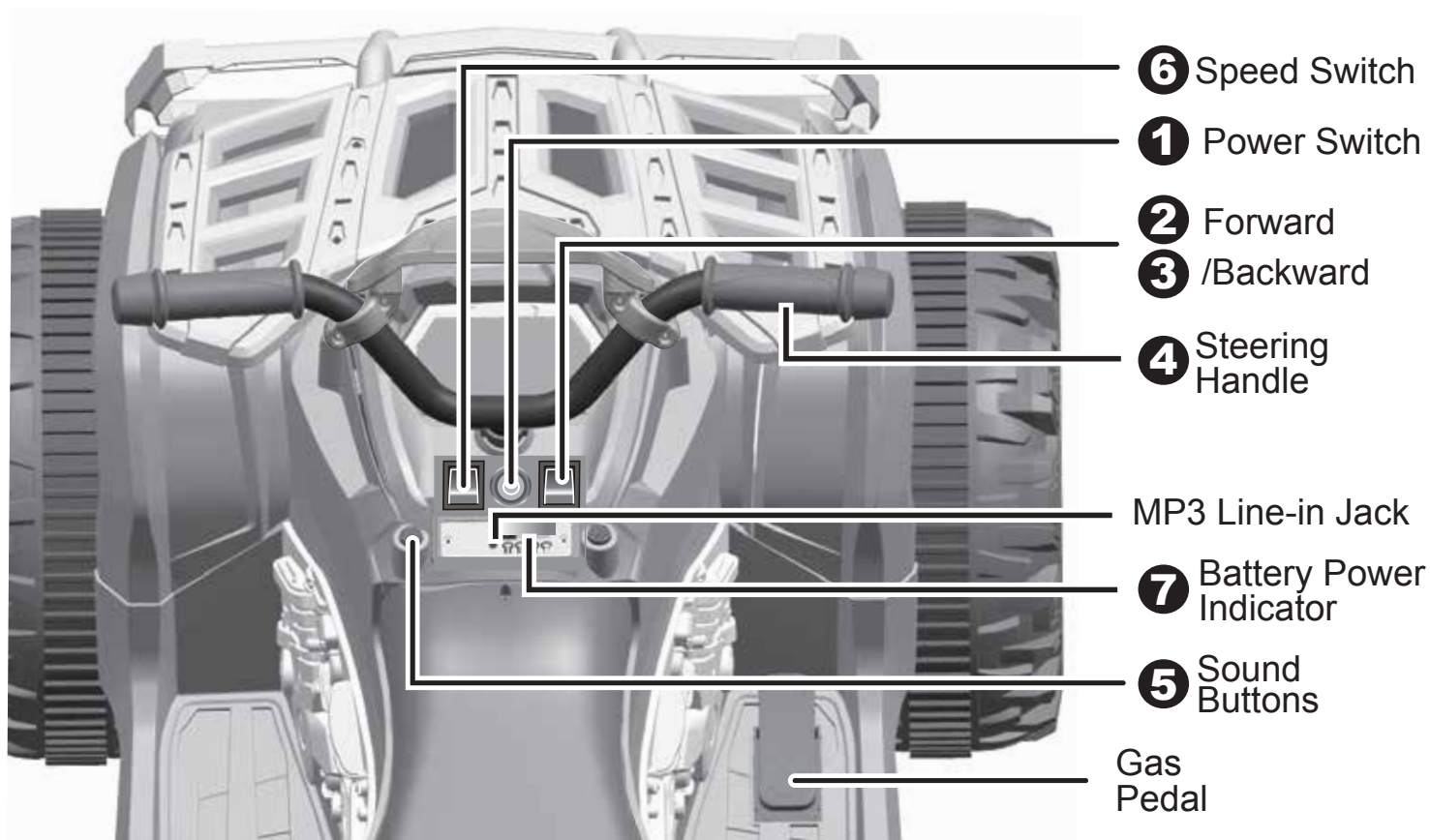

❶ Power

Press the Red Power switch once, the vehicle will be powered up. Press the button again to turn off the vehicle.

❷ Forward

Turn the switch to “Forward”, step on the Gas pedal, the vehicle will move forward, release the Gas pedal, the vehicle will stop.

❸ Backward

Turn the switch to “Backward”, step on the Gas pedal, the vehicle will move backward, release the Gas pedal, the vehicle will stop.

❹ Turn left/ right

While the vehicle is moving, use the steering wheel to turn left or right.

❺ Sound Effects

Horn Sound: Press the button for Horn Sound.

❻ Speed Switch

Turn the Switch to “High Speed” for high speed, “Low Speed” to low speed.

❼ Battery Power Indicator:

Check the power remaining of your battery.

Use Your New Ride-on

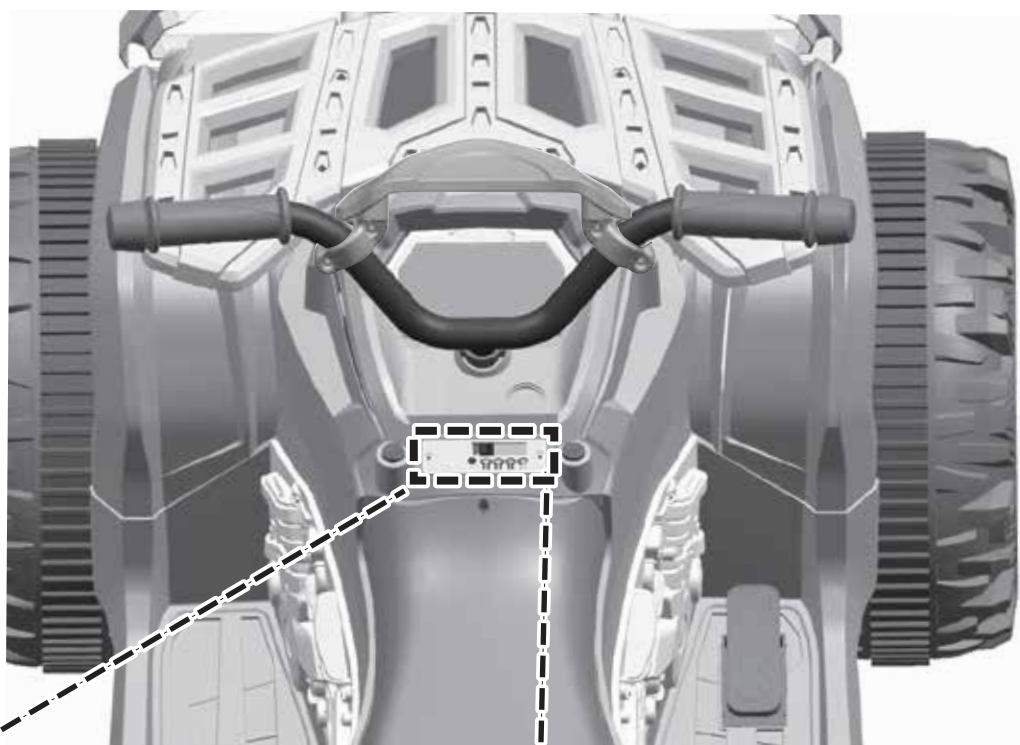

Radio & Sound Button Control Panel:

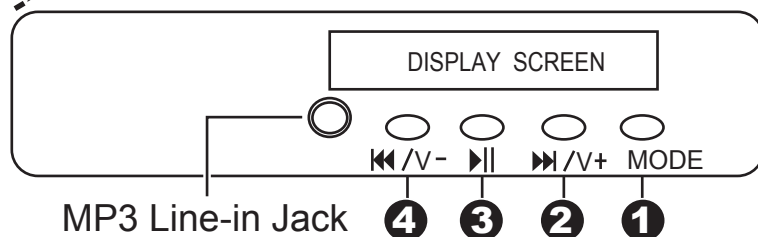

Button **1**: Switch between **Mode A** (Horn Sound mode) and **Mode B** (FM Radio mode)

Mode A (Horn Sound Mode)

Button **2**: Press once to play Horn Sound. Press and hold for 3 seconds to raise the volume.

Button **3**: Press once to play Horn Sound.

Button **4**: Press once to play Horn Sound. Press and hold for 3 seconds to Lower the volume.

Mode B (FM Radio Mode) ****Note****: For first time use, please press Button **3** once to auto search for Radio Channels. Wait until all channels are setup.

Button **2**: Press once to skip to next Radio Channel. Press and hold for 3 seconds to raise the volume.

Button **3**: Press once to auto search for Radio Channels.

Button **4**: Press once to skip to previous Radio Channel. Press and hold for 3 seconds to lower the volume.

Charging

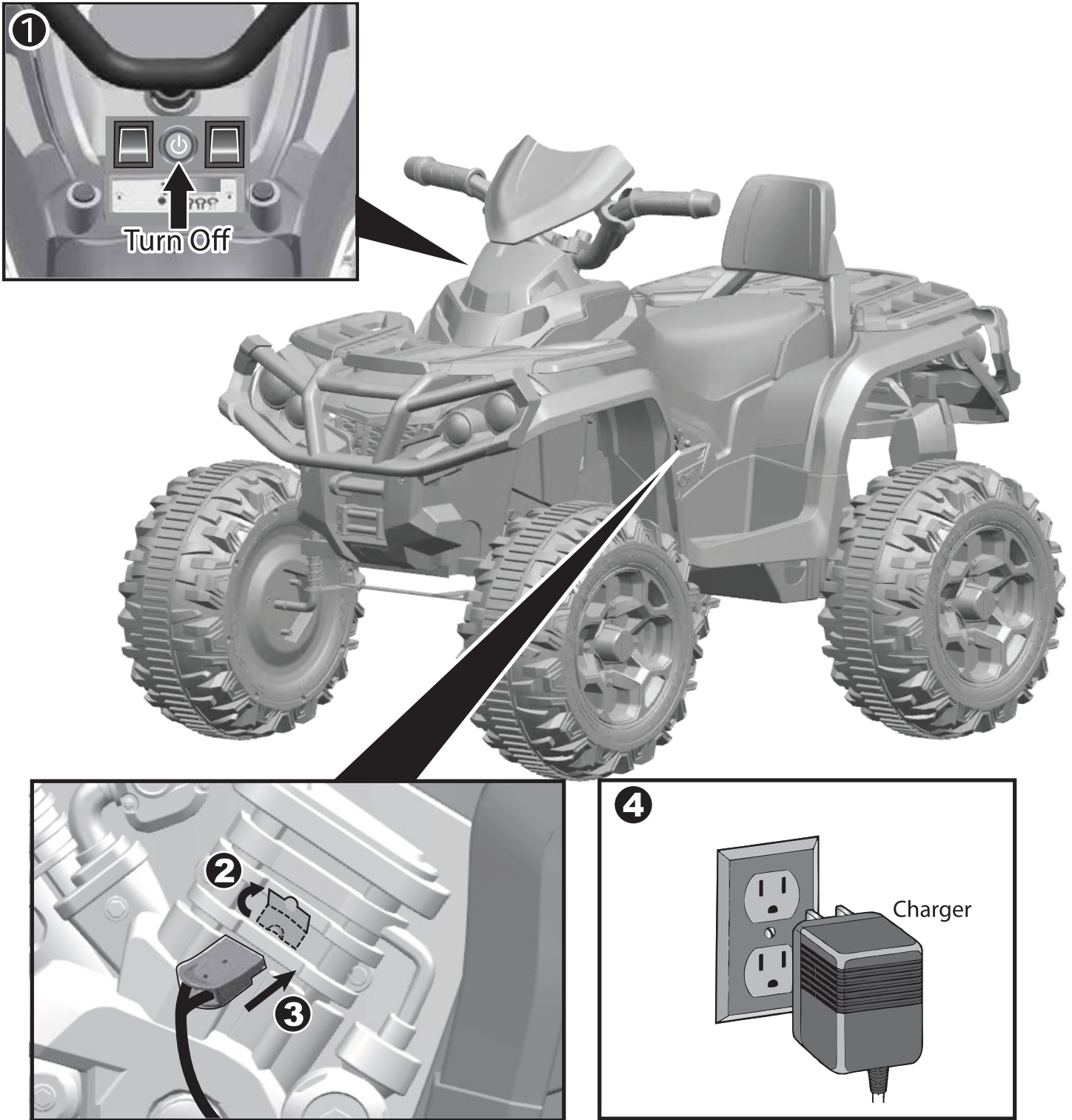

- 1** Make sure to turn off the power when charging.
- 2** Open the cover of the charging hole. (above the foot pedal)
- 3** Plug the charger port into the input socket.
- 4** Plug the charger plug into a wall outlet. The battery will begin charging.

Charging

WARNING!

- This product with **Charging Protection**: when charging, all functions will be cut off!
 - Only an adult can charge and recharge the battery!
-
- The POWER SWITCH must be turned to **OFF** position when charging.
 - Do not recharge the battery for more than 12 hours to avoid overheating the charger.
 - When the vehicle begins to run slowly, recharge the battery.
 - After each use or once a month minimum recharge time as 8 to 12 hours, less than 16 hours at most.
 - Your ride-on with a **Battery Power Indicator**, if the magnitude of voltage less than 11.0 when the ride-on is stop, please recharge the battery.

Fuse

The battery features a thermal fuse with a reset fuse that will automatically trip and cut all power to the vehicle if the motor, electric system or battery is overloaded. The fuse will reset and power will be restored after the unit is turned OFF for 20 seconds and then turned ON again. If the thermal fuse trips repeatedly during normal use, the vehicle may need repair.

To avoid losing power, follow these guidelines:

- Do not overload the vehicle.
- Do not tow anything behind the vehicle.
- Do not drive up steep slopes.
- Do not drive into fixed objects, which may cause the wheels to spin, causing the motor to overheat.
- Do not drive in very hot weather, components may overheat.
- Do not allow water or other liquids to come in contact with the battery or other electric components.
- Do not tamper with the electric system. Doing so may create a short, causing the fuse to trip.

Troubleshooting Guide

Problem	Possible Cause	Solution
Vehicle does not run	Battery low on power	Recharge battery.
	Thermal fuse has tripped	The fuse will reset automatically in 20 seconds.
	Battery connector or wires are loose	Check that the battery connectors are firmly plugged into each other. If wires are loose around the motor contact our Service Center please.
	Battery is dead	Replace battery, contact Our Service Center please.
	Electrical system is damaged	Contact Our Service Center please.
	Motor is damaged	Contact Our Service Center please.
Vehicle does not run very long	Battery is under charged	Check that the battery connectors are firmly plugged into each other when recharging
	Battery is old	Replace battery, contact Our Service Center please.
Vehicle runs sluggishly	Battery low on power	Recharge battery, contact Our Service Center please.
	Battery is old	Replace battery, contact Our Service Center please.
	Vehicle is overload	Reduce weight on vehicle. Maximum user weight is 88 lbs.
	Vehicle is being used in harsh conditions	Avoid using vehicle in harsh conditions ,see <Safety>.
Vehicle needs a push to go forward	Poor contact of wires or Connectors	Check that the battery connectors are firmly plugged into each other. If wires are loose around the motor, contact Our Service Center please.
	“Dead Spot” on motor	A dead spot means the electric power is not being delivered to the terminal connection and the vehicle needs repair. Contact Our Service Center please.
Difficult shifting from forward to reverse or vice-versa	Attempting to shift while the vehicle is motion	Completely stop the vehicle and shift, see <Use Your New Vehicle>
Loud grinding or clicking noises coming from motor or gear box	Motor or gears are damaged	Contact Our Service Center please.
Battery will not recharge	Battery connector or adapter connector is loose	Check that the battery connectors are firmly plugged into each other.
	Charger not plugged in	Check that the battery charger is plugged into a working wall outlet.
	Charger is not working	Contact Our Service Center please.
Charger feels warm when recharging	This is normal and not a cause for concern	<p style="text-align: center;">BEYOND INFINITY LIMITED - Our Service Center</p> <p style="text-align: center;">TOLL FREE: 1-888-458-3288</p> <p style="text-align: center;">E-mail: 2service@infinitybi.com</p>

Maintaining

- It is parents' responsibility to check main parts of the toy before using, must regularly examine for potential hazard, such as the battery, charge, cable or cord, plug, screws are fastening enclosure of other parts and that in the event of such damage, the toy must not be used until that damage had been properly removed.
- Make sure the plastic parts of the vehicle are not cracked or broken.
- Occasionally use a lightweight oil to lubricate moving parts such as wheels.
- Park the vehicle indoors and cover it with a tarp to protect it from wet weather.
- Keep the vehicle away from sources of heat, such as stoves and heaters. Plastic parts may melt.
- Recharge the battery after each use. Only an adult can handle the battery. Recharge the battery at least once a month when the vehicle is not being used.
- Do not wash the vehicle with a hose. Do not wash the vehicle with soap and water. Do not drive the vehicle in rainy or snowy weather. Water will damage the motor, electric system and battery.
- Clean the vehicle with a soft, dry cloth. To restore shine to plastic parts, use a non-wax furniture polish. Do not use car wax. Do not use abrasive cleaners.
- Do not drive the vehicle in loose dirt, sand or fine gravel which could damage the moving parts, motors or the electric system.
- When not using, all the electrical source should be turn off. Turn off the power switch and disconnect the battery connection.

Disposal Of Battery



- Your sealed lead-acid battery must be recycled or disposed of in an environmentally sound manner.
- Do not dispose of your lead-acid battery in a fire. The battery may explode or leak.
- Do not dispose of a lead-acid battery in your regular, household trash. The incineration, land filling or mixing of sealed lead-acid batteries with household trash is prohibited by law.

Attention

1. The charging work must be operated by adults.
2. The charger is not a toy, please don't let children to playwith, and cannot be used for other purposes.
3. Before charging, check the status of shell and electric wire and ensure they are in good conditions
4. When the battery runs out, please re-charge. It is unfavorable to store it without electricity.
5. The battery would be damaged if discharged excessively. The battery's positive electrode and negative electrode should be connected in the correct way, else it will cause danger. Re-charge it only with the charger provided.
6. If there is any abnormal situation appear when charging the battery, pls check and stop using it until after repair .
7. If you do not use this product for a long time, please keep charge the battery every three months.
8. Please remove the battery asap if it is damaged, and call back in case of leakage.
9. When replacing the battery, open the seat pad, unscrew and remove the old battery, and replace with a new one. Please connect the positive and negative electrodes correctly.
10. Non-rechargeable batteries cannot be recharged. Please take out the battery from the vehicle before charging. The charging work should be handled by adults.
11. Please connect the battery electrodes correctly. Do not mix the new and old batteries. If the battery runs out, please take it out from the product.
12. Disconnect the power supply when cleaning the vehicle, and the work must be performed under the supervision of adults.
13. The vehicle should not be used by children under the age of 3. Please keep this manual for future reference

Warranty

Warranty and customer service information provided in this manual only apply within the United States and Canada.

All Beyond Infinity vehicles are covered by a ninety day warranty against defects in materials or workmanship starting from the date of purchase from an authorized retailer.

The warranty protects the Beyond Infinity vehicle which has been used under normal circumstances, solely for the purpose for which it was intended and has been properly cared for and maintained. The warranty does not cover any damage caused by the customer, damage which is the result of normal wear and tear, damage from any alterations made by the customer or damage caused by any use for an unintended purpose.

You must keep the original purchase receipt for warranty registration and claims, and must inspect the vehicle upon purchase for any defects or missing parts.

(List Beyond infinity contacts, customer service number, email, etc, below)

BEYOND INFINITY LIMITED
TOLL FREE: 1-888-458-3288
E-mail: 2service@infinitybi.com

Item# 2779

Desc: Realtree ATV Racer Ride on

This device complies with part 15 of the FCC Rules. Operation is subject to the following two conditions:
(1) This device may not cause harmful interference, and
(2) this device must accept any interference received, including interference that may cause undesired operation.



WARNING:

To reduce the risk of injury, adult supervision is required, never use in roadways, near cars, on or near steep inclines or steps, swimming pools or other bodies of water, always wear shoes, and never allow more than one rider

NOTE: This equipment has been tested and found to comply with the limits for a Class B digital device, pursuant to Part 15 of the FCC Rules. These limits are designed to provide reasonable protection against harmful interference in a residential installation. This equipment generates, uses and can radiate radio frequency energy and, if not installed and used in accordance with the instructions, may cause harmful interference to radio communications. However, there is no guarantee that interference will not occur in a particular installation. If this equipment does cause harmful interference to radio or television reception, which can be determined by turning the equipment off and on, the user is encouraged to try to correct the interference by one or more of the following measures:

Reorient or relocate the receiving antenna.

Increase the separation between the equipment and receiver.

Connect the equipment into an outlet on a circuit different from that to which the receiver is connected.

Consult the dealer or experienced radio/TV technician for help.

Caution: changes or modifications not expressly approved by the party responsible for compliance could void the user's authority to operate the equipment.

**Only use the battery specified by the manufacturer.
Only use the charger specified by the manufacturer.**

Imported by:
Tractor Supply Co.
Brentwood, TN 37027, USA

Customer Service Toll Free No: 1-888-458-3288