

ARC-125DS PRO

STICK WELDING MACHINE

Dec., 2023



OPERATOR'S MANUAL

YESWELDER®

Copyright © YesWelder

 To help us serve you better, go to www.yeswelder.com

TABLE OF CONTENTS

SAFETY	01 - 04
---------------------	----------------

INSTALLATION SECTION	05 - 07
TECHNICAL SPECIFICATIONS	05
SAFETY PRECAUTIONS	06
SELECT SUITABLE LOCATION	06
STACKING	06
TILTING	06
INPUT CONNECTIONS	06
GROUND CONNECTION	06
INPUT POWER CONNECTION	07
OUTPUT CONNECTIONS	07
STICK WELDING	07
TIG WELDING	07

OPERATION	08 - 17
SAFETY INSTRUCTIONS	08
GENERAL DESCRIPTION	08
WELDING CAPABILITY	08
LIMITATIONS	08
CONTROLS AND OPERATIONAL FEATURES	09 - 10
WORK PIECE CLEANING BEFORE WELDING	11 - 17

ACCESSORIES	18
--------------------------	-----------

MAINTENANCE	19
SAFETY PRECAUTIONS	19
INPUT FILTER CAPACITOR DISCHARGE PROCEDURE	19
ROUTINE MAINTENANCE	19

TROUBLESHOOTING	20 - 21
HOW TO USE TROUBLESHOOTING GUIDE	20
TROUBLESHOOTING GUIDE	21

WIRING DIAGRAM	22
-----------------------------	-----------

SAFETY

⚠ WARNING

⚠ CALIFORNIA PROPOSITION 65 WARNINGS ⚠

Diesel engine exhaust and some of its constituents are known to the State of California to cause cancer, birth defects, and other reproductive harm.

The Above For Diesel Engines



FOR ENGINE powered equipment

1.a. Turn the engine off before troubleshooting and maintenance work unless the maintenance work requires it to be running.



1.b. Operate engines in open, well-ventilated areas or vent the engine exhaust fumes outdoors.



1.c. Do not add the fuel near an open flame welding arc or when the engine is running. Stop the engine and allow it to cool before refueling to prevent spilled fuel from vaporizing on contact with hot engine parts and igniting. Do not spill fuel when filling tank. If fuel is spilled, wipe it up and do not start engine until fumes have been eliminated.

1.d. Keep all equipment safety guards, covers and devices in position and in good repair. Keep hands, hair, clothing and tools away from V-belts, gears, fans and all other moving parts when starting, operating or repairing equipment.

1.e. In some cases it may be necessary to remove safety guards to perform required maintenance. Remove guards only when necessary and replace them when the maintenance requiring their removal is complete. Always use the greatest care when working near moving parts.



1.f. Do not put your hands near the engine fan. Do not attempt to override the governor or idler by pushing on the throttle control rods while the engine is running.

1.g. To prevent accidentally starting gasoline engines while turning the engine or welding generator during maintenance work, disconnect the spark plug wires, distributor cap or magneto wire as appropriate.

The engine exhaust from this product contains chemicals known to the State of California to cause cancer, birth defects, or other reproductive harm.

The Above For Gasoline Engines



1.h. To avoid scalding, do not remove the radiator pressure cap when the engine is hot.



ELECTRIC AND MAGNETIC FIELDS may be dangerous

2.a. Electric current flowing through any conductor causes localized Electric and Magnetic Fields (EMF). Welding current creates EMF fields around welding cables and welding machines.

2.b. EMF fields may interfere with some pacemakers, and welders having a pacemaker should consult their physician before welding.

2.c. Exposure to EMF fields in welding may have other health effects which are now not known.

2.d. All welders should use the following procedures in order to minimize exposure to EMF fields from the welding circuit:

2.d.1. Route the electrode and work cables together - Secure them with tape when possible.

2.d.2. Never coil the electrode lead around your body.

2.d.3. Do not place your body between the electrode and work cables. If the electrode cable is on your right side, the work cable should also be on your right side.

2.d.4. Connect the work cable to the workpiece as close as possible to the area being welded.

2.d.5. Do not work next to welding power source.



ELECTRIC SHOCK can kill

- 3.a. The electrode and work (or ground) circuits are electrically "hot" when the welder is on. Do not touch these "hot" parts with your bare skin or wet clothing. Wear dry, hole-free gloves to insulate hands.
- 3.b. Insulate yourself from work and ground using dry insulation. Make certain the insulation is large enough to cover your full area of physical contact with work and ground.

In addition to the normal safety precautions, if welding must be performed under electrically hazardous conditions (in damp locations or while wearing wet clothing; on metal structures such as floors, gratings or scaffolds; when in cramped positions such as sitting, kneeling or lying, if there is a high risk of unavoidable or accidental contact with the workpiece or ground) use the following equipment:

- Semiautomatic DC Constant Voltage (Wire) Welder.
- DC Manual (Stick) Welder.
- AC Welder with Reduced Voltage Control.

- 3.c. In semiautomatic or automatic wire welding, the electrode, electrode reel, welding head, nozzle or semiautomatic welding gun are also electrically "hot".
- 3.d. Always be sure the work cable makes a good electrical connection with the metal being welded. The connection should be as close as possible to the area being welded.
- 3.e. Ground the work or metal to be welded to a good electrical (earth) ground.
- 3.f. Maintain the electrode holder, work clamp, welding cable and welding machine in good, safe operating condition. Replace damaged insulation.
- 3.g. Never dip the electrode in water for cooling.
- 3.h. Never simultaneously touch electrically "hot" parts of electrode holders connected to two welders because voltage between the two can be the total of the open circuit voltage of both welders.
- 3.i. When working above floor level, use a safety belt to protect yourself from a fall should you get a shock.
- 3.j. Also see Items 6.c. and 8.



ARC RAYS can burn.

- 4.a. Use a shield with the proper filter and cover plates to protect your eyes from sparks and the rays of the arc when welding or observing open arc welding. Headshield and filter lens should conform to ANSI Z87.1 standards.
- 4.b. Use suitable clothing made from durable flame-resistant material to protect your skin and that of your helpers from the arc rays.
- 4.c. Protect other nearby personnel with suitable, non-flammable screening and/or warn them not to watch the arc nor expose themselves to the arc rays or to hot spatter or metal.



FUMES AND GASES can be dangerous

- 5.a. Welding may produce fumes and gases hazardous to health. Avoid breathing these fumes and gases. When welding, keep your head out of the fume. Use enough ventilation and/or exhaust at the arc to keep fumes and gases away from the breathing zone.
- When welding with electrodes which require special ventilation such as stainless or hard facing (see instructions on container or MSDS) or on lead or cadmium plated steel and other metals or coatings which produce highly toxic fumes, keep exposure as low as possible and below Threshold Limit Values (TLV) using local exhaust or mechanical ventilation. In confined spaces or in some circumstances, outdoors, a respirator may be required. Additional precautions are also required when welding on galvanized steel.**
- 5.b. The operation of welding fume control equipment is affected by various factors including proper use and positioning of the equipment, maintenance of the equipment and the specific welding procedure and application involved. Worker exposure level should be checked upon installation and periodically thereafter to be certain it is within applicable OSHA PEL and ACGIH TLV limits.
- 5.c. Do not weld in locations near chlorinated hydrocarbon vapors coming from degreasing, cleaning or spraying operations. The heat and rays of the arc can react with solvent vapors to form phosgene, a highly toxic gas, and other irritating products.
- 5.d. Shielding gases used for arc welding can displace air and cause injury or death. Always use enough ventilation, especially in confined areas, to insure breathing air is safe.
- 5.e. Read and understand the manufacturer's instructions for this equipment and the consumables to be used, including the material safety data sheet (MSDS) and follow your employer's safety practices. MSDS forms are available from your welding distributor or from the manufacturer.
- 5.f. Also see item 1.b.

SAFETY



WELDING and CUTTING SPARKS can cause fire or explosion.

- 6.a. Remove fire hazards from the welding area. If this is not possible, cover them to prevent the welding sparks from starting a fire. Remember that welding sparks and hot materials from welding can easily go through small cracks and openings to adjacent areas. Avoid welding near hydraulic lines. Have a fire extinguisher readily available.
- 6.b. Where compressed gases are to be used at the job site, special precautions should be used to prevent hazardous situations. Refer to "Safety in Welding and Cutting" (ANSI Standard Z49.1) and the operating information for the equipment being used.
- 6.c. When not welding, make certain no part of the electrode circuit is touching the work or ground. Accidental contact can cause overheating and create a fire hazard.
- 6.d. Do not heat, cut or weld tanks, drums or containers until the proper steps have been taken to insure that such procedures will not cause flammable or toxic vapors from substances inside. They can cause an explosion even though they have been "cleaned". For information, purchase "Recommended Safe Practices for the Preparation for Welding and Cutting of Containers and Piping That Have Held Hazardous Substances", AWS F4.1 from the American Welding Society (see address above).
- 6.e. Vent hollow castings or containers before heating, cutting or welding. They may explode.
- 6.f. Sparks and spatter are thrown from the welding arc. Wear oil free protective garments such as leather gloves, heavy shirt, cuffless trousers, high shoes and a cap over your hair. Wear ear plugs when welding out of position or in confined places. Always wear safety glasses with side shields when in a welding area.
- 6.g. Connect the work cable to the work as close to the welding area as practical. Work cables connected to the building framework or other locations away from the welding area increase the possibility of the welding current passing through lifting chains, crane cables or other alternate circuits. This can create fire hazards or overheat lifting chains or cables until they fail.
- 6.h. Also see item 1.c.
- 6.i. Read and follow NFPA 51B "Standard for Fire Prevention During Welding, Cutting and Other Hot Work", available from NFPA, 1 Batterymarch Park, PO box 9101, Quincy, Ma 022690-9101.
- 6.j. Do not use a welding power source for pipe thawing.



CYLINDER may explode if damaged.

- 7.a. Use only compressed gas cylinders containing the correct shielding gas for the process used and properly operating regulators designed for the gas and pressure used. All hoses, fittings, etc. should be suitable for the application and maintained in good condition.
- 7.b. Always keep cylinders in an upright position securely chained to an undercarriage or fixed support.
- 7.c. Cylinders should be located:
- way from areas where they may be struck or subjected to physical damage.
 - A safe distance from arc welding or cutting operations and any other source of heat, sparks, or flame.
- 7.d. Never allow the electrode, electrode holder or any other electrically "hot" parts to touch a cylinder.
- 7.e. Keep your head and face away from the cylinder valve outlet when opening the cylinder valve.
- 7.f. Valve protection caps should always be in place and hand tight except when the cylinder is in use or connected for use.
- 7.g. Read and follow the instructions on compressed gas cylinders, associated equipment, and CGA publication P-1, "Precautions for Safe Handling of Compressed Gases in Cylinders," available from the Compressed Gas Association 1235 Jefferson Davis Highway, Arlington, VA 22202.



FOR ELECTRICALLY powered equipment.

- 8.a. Install equipment in accordance with the U.S. National Electrical Code, all local codes and the manufacturer's recommendations.
- 8.b. Ground the equipment in accordance with the U.S. National Electrical Code and the manufacturer's recommendations.

PRÉCAUTIONS DE SÛRETÉ

Pour votre propre protection lire et observer toutes les instructions et les précautions de sûreté spécifiques qui paraissent dans ce manuel aussi bien que les précautions de sûreté générales suivantes:

Sûreté Pour Soudage A L'Arc

1. Protégez-vous contre la secousse électrique:
 - a. Les circuits à l'électrode et à la pièce sont sous tension quand la machine à souder est en marche. Eviter toujours tout contact entre les parties sous tension et la peau nue ou les vêtements mouillés. Porter des gants secs et sans trous pour isoler les mains.
 - b. Faire très attention de bien s'isoler de la masse quand on soude dans des endroits humides, ou sur un plancher métallique ou des grilles métalliques, principalement dans les positions assis ou couché pour lesquelles une grande partie du corps peut être en contact avec la masse.
 - c. Maintenir le porte-électrode, la pince de masse, le câble de soudage et la machine à souder en bon et sûr état de fonctionnement.
 - d. Ne jamais plonger le porte-électrode dans l'eau pour le refroidir.
 - e. Ne jamais toucher simultanément les parties sous tension des porte-électrodes connectés à deux machines à souder parce que la tension entre les deux pinces peut être le total de la tension à vide des deux machines.
 - f. Si on utilise la machine à souder comme une source de courant pour soudage semi-automatique, ces précautions pour le porte-électrode s'appliquent aussi au pistolet de soudage.
2. Dans le cas de travail au dessus du niveau du sol, se protéger contre les chutes dans le cas où on reçoit un choc. Ne jamais enrouler le câble-électrode autour de n'importe quelle partie du corps.
3. Un coup d'arc peut être plus sévère qu'un coup de soleil, donc:
 - a. Utiliser un bon masque avec un verre filtrant approprié ainsi qu'un verre blanc afin de se protéger les yeux du rayonnement de l'arc et des projections quand on soude ou quand on regarde l'arc.
 - b. Porter des vêtements convénables afin de protéger la peau de soudeur et des aides contre le rayonnement de l'arc.
 - c. Protéger l'autre personnel travaillant à proximité au soudage à l'aide d'écrans appropriés et non-inflammables.
4. Des gouttes de laitier en fusion sont émises de l'arc de soudage. Se protéger avec des vêtements de protection libres de l'huile, tels que les gants en cuir, chemise épaisse, pantalons sans revers, et chaussures montantes.
5. Toujours porter des lunettes de sécurité dans la zone de soudage. Utiliser des lunettes avec écrans latéraux dans les zones où l'on pique le laitier.

6. Eloigner les matériaux inflammables ou les recouvrir afin de prévenir tout risque d'incendie dû aux étincelles.
7. Quand on ne soude pas, poser la pince à un endroit isolé de la masse. Un court-circuit accidentel peut provoquer un échauffement et un risque d'incendie.
8. S'assurer que la masse est connectée le plus près possible de la zone de travail qu'il est pratique de le faire. Si on place la masse sur la charpente de la construction ou d'autres endroits éloignés de la zone de travail, on augmente le risque de voir passer le courant de soudage par les chaînes de levage, câbles de grue, ou autres circuits. Cela peut provoquer des risques d'incendie ou d'échauffement des chaînes et des câbles jusqu'à ce qu'ils se rompent.
9. Assurer une ventilation suffisante dans la zone de soudage. Ceci est particulièrement important pour le soudage de tôles galvanisées plombées, ou cadmiées ou tout autre métal qui produit des fumées toxiques.
10. Ne pas souder en présence de vapeurs de chlore provenant d'opérations de dégraissage, nettoyage ou pistolage. La chaleur ou les rayons de l'arc peuvent réagir avec les vapeurs du solvant pour produire du phosgène (gas fortement toxique) ou autres produits irritants.
11. Pour obtenir de plus amples renseignements sur la sûreté, voir le code "Code for safety in welding and cutting" CSA Standard W 117.2-1974.

PRÉCAUTIONS DE SÛRETÉ POUR LES MACHINES À SOUDER À TRANSFORMATEUR ET À REDRESSEUR

1. Relier à la terre le châssis du poste conformément au code de l'électricité et aux recommandations du fabricant. Le dispositif de montage ou la pièce à souder doit être branché à une bonne mise à la terre.
2. Autant que possible, l'installation et l'entretien du poste seront effectués par un électricien qualifié.
3. Avant de faire des travaux à l'intérieur de poste, la débrancher à l'interrupteur à la boîte de fusibles.
4. Garder tous les couvercles et dispositifs de sûreté à leur place.

INSTALLATION

TECHNICAL SPECIFICATION: ARC-125DS PRO

INPUT-SINGLE PHASE ONLY				
Standard Voltage/Frequency			Input Current	
110V±10% 50/60Hz			I _{1 max} =40A, I _{1 eff} =25A	
RATED OUTPUT – DC ONLY				
Voltage	Mode	Duty Cycle	Current	Volts at Rated Current
110V	SMAW	60%	125A	25V
		100%	97A	24V
OUTPUT RANGE				
Voltage	Mode	Open Circuit Voltage	Welding Current Range	Welding Voltage Range
110V	SMAW	60V	20A~125A	10.8V~25V
PHYSICAL DIMENSIONS				
Machine	Length	Width	Depth	Weight
ARC-125DS PRO	9.3in.(235mm)	3.7in.(95mm)	5.1in.(130mm)	Approx. 4.4lbs.(2.0kg)
TEMPERATURE RANGE				
Operating Temperature Range			-10°C~+40°C(14°F~104°F)	
Storage Temperature Range			-25°C~+55°C(-13°F~131°F)	

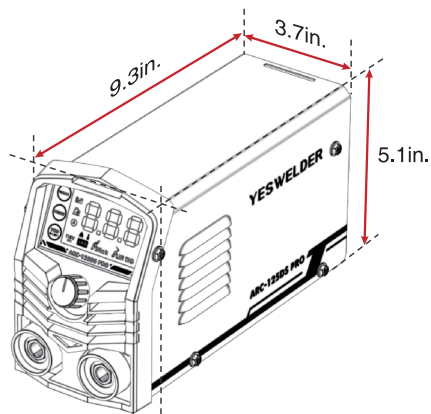

INSTALLATION

Read entire installation section before starting installation.

SAFETY PRECAUTIONS

WARNING



ELECTRIC SHOCK can kill.

- Only qualified personnel should perform this installation.
- Disconnect input power by removing plug from receptacle before working inside ARC-125DS PRO. Allow machine to sit for 5 minutes minimum to allow the power capacitors to discharge before working inside this

equipment.

- Insulate yourself from the work and ground.
- Always wear dry insulating gloves.
- Always connect the ARC-125DS PRO to a power supply grounded according to the National Electrical Code and local codes.

SELECT SUITABLE LOCATION

This machine can operate in harsh environments. However, it is important that simple preventative measures are followed to assure long life and reliable operation:

- Do not use this machine for pipe thawing.
- This machine must be located where there is free circulation of clean air without restrictions for air movement to and from the air vents. Do not cover the machine with paper, cloth or rags when switched on.
- Dirt and dust that can be drawn into the machine should be kept to a minimum.
- This machine has a protection rating of IP21S. Keep it dry when possible and do not place it on wet ground or in puddles.
- Locate the machine away from radio controlled machinery. Normal operation may adversely affect the operation of nearby radio controlled machinery, which may result in injury or equipment damage. Read the section on electromagnetic compatibility in this manual.
- Do not operate in areas with an ambient temperature greater than 40°C.

STACKING

The Invertec ARC-125DS PRO cannot be stacked.

TILTING

Place the machine directly on a secure, level surface. Do not place or operate this machine on a surface with an incline greater than 15° from horizontal. The machine may topple over if this procedure is not followed.

INPUT CONNECTIONS

WARNING



ELECTRIC SHOCK can kill.

- Have a qualified electrician install and service this equipment.
- Disconnect input power by removing plug from receptacle before working inside ARC-125DS PRO. Allow machine to sit for 5 minutes minimum to allow the

power capacitors to discharge before working inside this equipment.

- Do not touch electrically live parts.

GROUND CONNECTION

CAUTION

A grounding conductor is supplied in the input cord, it is important that the supply receptacle ground is connected.

WARNING

This installation should be performed by a qualified electrician to ensure correct connections of the leads to the plug spades.

- The electrical system must be made by skilled technicians with the specific professional and technical qualifications and in compliance with the regulations in force in the country where the equipment is installed.

- The welding power source supply cable is provided with a green or yellow/green wire that must ALWAYS be earthed. This green or yellow/green wire must NEVER be used with other voltage conductors.

- Install only plugs that confirm with safety regulations.

INSTALLATION

INPUT POWER CONNECTION

Check the input voltage, phase, and frequency supplied to this machine before turning it on. The allowable input voltage is indicated in the technical specification section of this manual and on the rating plate of the machine. Be sure that the machine is grounded.

Make sure the power available at the input connection is adequate for normal operation of the machine.

OUTPUT CONNECTIONS

Refer to the following sections for more information on connecting the machine for operation of stick welding or TIG welding.

WARNING



ELECTRIC SHOCK can kill.

- Keep the electrode holder and cable insulation in good condition.
- Do not touch electrically live parts or electrode with skin or wet clothing.
- Insulate yourself from work and ground.
- Turn the input line Switch on the ARC-125DS PRO "off" before connecting or disconnecting out-put cables or other equipment.

STICK WELDING

First determine the proper electrode polarity for the electrode to be used. Consult the electrode data for this information. Then connect the output cables to the output terminals of the machine for the selected polarity. Shown here is the connection method for DC (+) welding. (SEE FIGURE A.1)

Connect the electrode cable to the (+) terminal and the work clamp to the (-) terminal. Insert the connector with the key lining up with the keyway turn clockwise. Do not over tighten.

For DC (-) welding, switch the cable connections at the machine so that the electrode cable is connected to (-) and the work clamp is connected to (+).

FIGURE A.1

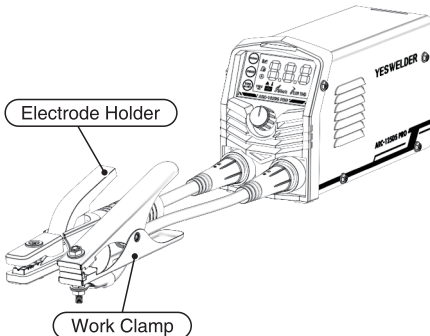

TIG WELDING

This machine does not have a built-in gas solenoid, so a one piece gas valve TIG Torch is required. Most TIG welding is done with DC (-) polarity shown here. (SEE FIGURE A.2)

Connect the torch cable to the (-) terminal of the machine and the work clamp to the (+) terminal. Insert the connector with the key lining up with the keyway and turn clockwise. Do not over tighten.

FIGURE A.2

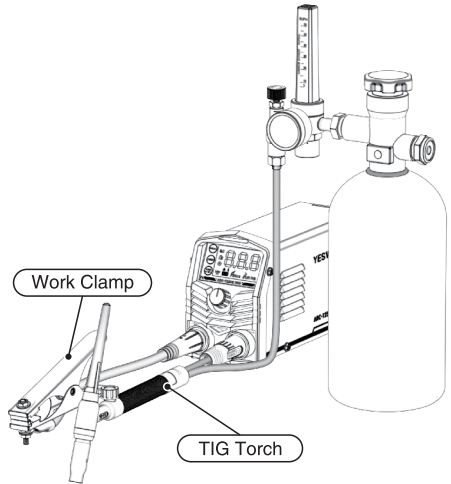

OPERATION

Read and understand this entire section before operating your machine.

SAFETY INSTRUCTIONS

WARNING



ELECTRIC SHOCK can kill.

- Do not touch electrically live parts such as output terminals or internal wiring.
- Insulate yourself from the work and ground.
- Always wear dry insulating gloves.



FUMES AND GASES can be dangerous.

- Keep your head out of fumes.
- Use ventilation or exhaust to remove fumes from breathing zone.



WELDING, CUTTING and GOUGING SPARKS can cause fire or explosion

- Keep flammable material away.
- Do not weld, cut or gouge on containers that have held combustibles.



ARC RAYS can burn.

- Wear eye, ear and body protection.

Only qualified personnel should operate this equipment. Observe all safety information throughout this manual.

GENERAL DESCRIPTION

The ARC-125DS PRO is a 125 amp arc welding power source which utilizes single phase input power, to produce constant current output. The welding response of this machine has been optimized for stick (SMAW) and LIFT TIG (GTAW).

WELDING CAPABILITY

The Inverter ARC-125DS PRO is rated at 125 amps, 28.2 volts, at 60% duty cycle on a ten minute basis. It is capable of higher duty cycles at lower output currents(1). If the duty cycle is exceeded, a thermal protector will shut off the output until the machine cools. See Technical Specifications in the Installation Section for other rated outputs.

LIMITATIONS

The ARC-125DS PRO is not recommended for pipe thawing.

(1) Refer to Technical Specifications in the Installation Section for other ratings.

OPERATION

CONTROLS AND OPERATIONAL FEATURES



1. Welding Mode Button
2. Parameter Button
3. Digital Display
4. VRD Button
5. Value Knob

6. Positive Output Terminal
7. Negative Output Terminal
8. Input Power Cable
9. Power Switch
10. Fan

Note:

- The “protection indicator light” will come on if the duty cycle is exceeded. It shows that the inner temperature is over the permitted level, the machine should be stopped being used to allow it cool down. Welding can be continued after the “protection indicator light” is off.
- The power source should be switched off when not in use.
- Welders should wear protective clothing and welding helmet to prevent injury from arc and thermal radiation.
- Care should be taken so as not to expose others to the welding arc.
- Do not weld near inflammable or explosive materials.

OPERATION

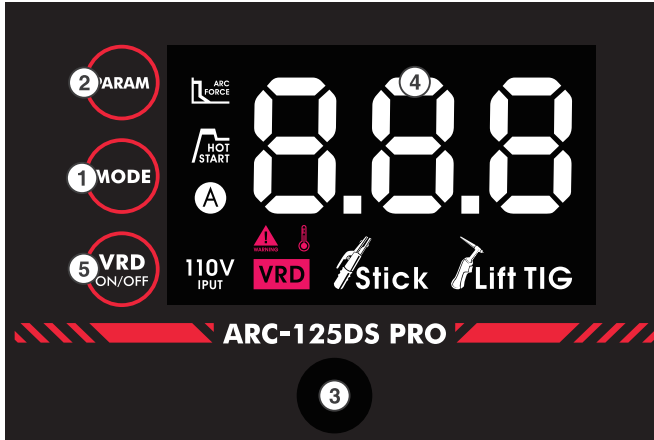

1. Mode Switch

For switching welding mode: Stick welding, Lift TIG welding

2. Parameter Switch

Stick mode: For switching amperage/arc force/hot start preset.

Lift TIG: For amperage preset.

3. Value Knob

For adjusting the value of the amperage/arc force level/hot start level.

4. VRD Knob

- Turn VRD function on or off (Available in STICK mode only). VRD, also known as a Voltage Reduction Device. It is a safety device that reduces the voltage to prevent electric shock, especially when welding in humid environments. For a better welding experience, welder can also turn off this function during welding.

5. Digital Display

- When switching the welding mode, the corresponding indicator will light up.
- When switching the parameter, the corresponding indicator will light up. (On Stick mode, only the indicator of amperage, arc force and hot start can light up; On Lift TIG mode, only the indicator of amperage can light up).
- When adjusting amperage, the degree indicator near syneergic knob will gradually light up/off to indicate an increase or decrease in degree.
- The protection indicator will turn on when the machine is overheated or over-current/low voltage. When the indicator turns off, the machine will work normally again.

OPERATION

WORK PIECE CLEANING BEFORE WELDING

Please keep the workpiece clean, remove existing rust, greasy dirt, water and paint, etc.

Stick Welding Steps

- Connect the electrode lead to the positive (+) output terminal on the front of the machine.
- Connect the work clamp lead to the negative (-) output terminal on the front of the machine.
- Turn on the power switch, and the fan will work.
- Set the welding mode button on "STICK".
- set the welding amperage (20-125A) with the knob.



- If necessary, set the "PARAM" button on "ARC FORCE" to adjust the arc force level (0-10). The arc force function can maintain arc stability, control potential arcs, increase welding depth, etc.



OPERATION

- When setting the "ARC FORCE" function to a value between 1-10, the "ARC FORCE indicator light" will remain on when returning to the main interface. If the "ARC FORCE" function is set to 0, the "ARC FORCE indicator light" will turn off when returning to the main interface.



- If necessary, set the "PARAM" button on "HOT START" to adjust the hot start level (0-10). The hot start function can increase the success rate of arc initiation, making it easier to start the arc.



OPERATION

- When setting the "HOT START" function to a value between 1-10, the "HOT START indicator light" will remain on when returning to the main interface. If the "HOT START" function is set to 0, the "HOT START indicator light" will turn off when returning to the main interface.



- Take up the electrode holder, install the welding rod and point the rod into the joint to be welded, scratch the work piece to start the arc.

Lift TIG Welding Steps (Optional TIG Torch Required)

- The TIG welding torch should be connected to the negative (-) output terminal, and the work clamp lead to the positive (+) output terminal.
- Turn on the power switch, and the fan will work.
- Turn on the gas regulator on the gas cylinder, the gas pressure is shown on the gauge.
- Set the welding mode button on "LIFT TIG".
- set the welding amperage (15-125A) with the knob.



ACCESSORIES



1. ARC-125DS PRO STICK WELDER
2. WORK CLAMP
3. ELECTRODE HOLDER

MAINTENANCE

SAFETY PRECAUTIONS

WARNING



ELECTRIC SHOCK can kill.

- Have an electrician install and service this equipment.
- Turn the input power off at the fuse box, disconnect supply lines and allow machine to sit for five minutes minimum to allow the power capacitors to discharge before working inside this equipment.
- Do not touch electrically hot parts.

INPUT FILTER CAPACITOR DISCHARGE PROCEDURE

WARNING

For any maintenance or repair operations it is recommended to contact YESWELDER, support@yeswelder.com or personnel will null and void the manufacturers warranty.

WARNING

The machine has internal capacitors which are charged to a high voltage during power-on conditions. This voltage is dangerous and must be discharged before the machine can be serviced. Discharging is done automatically by the machine each time the power is switched off. However, you must allow the machine to sit for at least 5 minutes to allow time for the process to take place.

ROUTINE MAINTENANCE

The frequency of the maintenance operations may vary in accordance with the working environment. Any noticeable damage should be reported immediately.

- Check cables and connections integrity. Replace, if necessary.
- Clean the power source inside by means of low - pressure compressed air.
- Keep the machine clean. Use a soft dry cloth to clean the external case, especially the airflow inlet/outlet louvers.

WARNING

Do not open this machine and do not introduce anything into its openings. Power supply must be disconnected from the machine before each maintenance and service. After each repair, perform proper tests to ensure safety.

CAUTION

Power supply must be disconnected from the machine before each maintenance and service. Always use gloves in compliance with the safety standards.

TROUBLESHOOTING

HOW TO USE TROUBLESHOOTING GUIDE

This Troubleshooting Guide is provided to help you locate and repair possible machine malfunctions. Simply follow the three-step procedure listed below.

Step 1. LOCATE PROBLEM (SYMPTOM).

Look under the column labeled "PROBLEMS (SYMPTOMS)". This column describes possible symptoms that the machine may exhibit. Find the listing that best describes the symptom that the machine is exhibiting.

Step 2. POSSIBLE CAUSE.

The second column labeled "POSSIBLE CAUSE" lists the obvious external possibilities that may contribute to the machine symptom.

Step 3. RECOMMENDED COURSE OF ACTION.

This column provides a course of action for the Possible Cause, generally it states to contact your local Lincoln Authorized Field Service Facility.

If you do not understand or are unable to perform the Recommended Course of Action safely, **Contact YESWELDER, support@yeswelder.com.**

Observe all Safety Guidelines detailed throughout this manual

PROBLEMS (SYMPTOMS)	POSSIBLE CAUSE	RECOMMENDED COURSE OF ACTION
PROBLEMS IN STICK WELDING		
Excessive spatter	<ol style="list-style-type: none"> 1. Long arc 2. High current 	If all recommended possible areas of misadjustment have been checked and the problem persists, Contact YESWELDER, "support@yeswelder.com" .
Craters	<ol style="list-style-type: none"> 1. Fast movement of the electrode away from piece. 	
Inclusions	<ol style="list-style-type: none"> 1. Poor cleanliness or distribution of the Welding passes. 2. Improper movement of the electrode. 	
Insufficient penetration	<ol style="list-style-type: none"> 1. High progression speed. 2. Welding current too low. 3. Narrow chamfering. 	
Sticking	<ol style="list-style-type: none"> 1. Arc too short. 2. Current too low. 	
Porosity	<ol style="list-style-type: none"> 1. Humidity in electrode. 2. Long arc. 	
Cracks	<ol style="list-style-type: none"> 1. Current too high. 2. Dirty materials. 3. Hydrogen in weld (present on electrode coating). 	

 **CAUTION**

If for any reason you do not understand the test procedures or are unable to perform the tests/repairs safely, **Contact YESWELDER, "support@yeswelder.com"**.

TROUBLESHOOTING

Observe all Safety Guidelines detailed throughout this manual

PROBLEMS (SYMPTOMS)	POSSIBLE CAUSE	RECOMMENDED COURSE OF ACTION
PROBLEMS IN TIG WELDING		If all recommended possible areas of misadjustment have been checked and the problem persists, Contact YESWELDER, "support@yeswelder.com" .
Oxidation	<ol style="list-style-type: none"> 1. Insufficient gas. 2. No protection on the back side. 	
Tungsten inclusions	<ol style="list-style-type: none"> 1. Incorrect electrode sharpening. 2. Electrode too small. 3. Operating failure (contact of the tip with the workpiece). 	
Porosity	<ol style="list-style-type: none"> 1. Dirt on the edges. 2. Dirt on the filler material. 3. Excessive travel speed. 4. Current intensity too low. 	
Hot cracking	<ol style="list-style-type: none"> 1. Unsuitable filler material. 2. High heat supply. 3. Dirty materials. 	

Observe all Safety Guidelines detailed throughout this manual

PROBLEMS (SYMPTOMS)	POSSIBLE CAUSE	RECOMMENDED COURSE OF ACTION
ELECTRICAL FAILURES		If all recommended possible areas of misadjustment have been checked and the problem persists, Contact YESWELDER, "support@yeswelder.com" .
Machine fails to come on (Power LED off)	<ol style="list-style-type: none"> 1. No Input Voltage. 2. Faulty supply plug or cable. 	
Thermal overload (Thermal LED on)	<ol style="list-style-type: none"> 1. Unit has been operated beyond its capacity rating. 2. Airflow through machine is restricted or fan has failed. 	

			
<p>WARNING</p>	<ul style="list-style-type: none"> • Do not touch electrically live parts or electrode with skin or wet clothing. • Insulate yourself from work and ground. 	<ul style="list-style-type: none"> • Keep flammable materials away. 	<ul style="list-style-type: none"> • Wear eye, ear and body protection.
<p>Spanish AVISO DE PRECAUCION</p>	<ul style="list-style-type: none"> • No toque las partes o los electrodos bajo carga con la piel o ropa mojada. • Aíslese del trabajo y de la tierra. 	<ul style="list-style-type: none"> • Mantenga el material combustible fuera del área de trabajo. 	<ul style="list-style-type: none"> • Protéjase los ojos, los oídos y el cuerpo.
<p>French ATTENTION</p>	<ul style="list-style-type: none"> • Ne laissez ni la peau ni des vêtements mouillés entrer en contact avec des pièces sous tension. • Isolez-vous du travail et de la terre. 	<ul style="list-style-type: none"> • Gardez à l'écart de tout matériel inflammable. 	<ul style="list-style-type: none"> • Protégez vos yeux, vos oreilles et votre corps.
<p>German WARNUNG</p>	<ul style="list-style-type: none"> • Berühren Sie keine stromführenden Teile oder Elektroden mit Ihrem Körper oder feuchter Kleidung! • Isolieren Sie sich von den Elektroden und dem Erdboden! 	<ul style="list-style-type: none"> • Entfernen Sie brennbares Material! 	<ul style="list-style-type: none"> • Tragen Sie Augen-, Ohren- und Körperschutz!
<p>Portuguese ATENÇÃO</p>	<ul style="list-style-type: none"> • Não toque partes elétricas e electrodos com a pele ou roupa molhada. • Isole-se da peça e terra. 	<ul style="list-style-type: none"> • Mantenha inflamáveis bem guardados. 	<ul style="list-style-type: none"> • Use proteção para a vista, ouvido e corpo.
<p>Japanese 注意事項</p>	<ul style="list-style-type: none"> ● 通電中の電気部品、又は溶材にヒフやぬれた布で触れないこと。 ● 施工物やアースから身体が絶縁されている様にして下さい。 	<ul style="list-style-type: none"> ● 燃えやすいものの側での溶接作業は絶対にしてはなりません。 	<ul style="list-style-type: none"> ● 目、耳及び身体に保護具をして下さい。
<p>Chinese 警告</p>	<ul style="list-style-type: none"> ● 皮肤或湿衣物切勿接觸帶電部件及銅條。 ● 使你自已與地面和工件絕緣。 	<ul style="list-style-type: none"> ● 把一切易燃物品移離工作場所。 	<ul style="list-style-type: none"> ● 佩戴眼、耳及身體勞動保護用具。
<p>Korean 위험</p>	<ul style="list-style-type: none"> ● 전도체나 용접봉을 젖은 환경 또는 피부로 절대 접촉치 마십시오. ● 모재와 접지를 접촉치 마십시오. 	<ul style="list-style-type: none"> ● 인화성 물질을 접근 시키지 마십시오. 	<ul style="list-style-type: none"> ● 눈, 귀와 몸에 보호장구를 착용하십시오.
<p>Arabic تحذير</p>	<ul style="list-style-type: none"> ● لا تلمس الأجزاء التي يسري فيها التيار الكهربائي أو الأقطاب بجلد الجسم أو الملابس المبللة بالماء. ● ضع عازلا على جسمك خلال العمل. 	<ul style="list-style-type: none"> ● ضع المواد القابلة للاشتعال في مكان بعيد. 	<ul style="list-style-type: none"> ● ضع أدوات وملابس واقية على عينيك وأذنيك وجسمك.

READ AND UNDERSTAND THE MANUFACTURER'S INSTRUCTION FOR THIS EQUIPMENT AND THE CONSUMABLES TO BE USED AND FOLLOW YOUR EMPLOYER'S SAFETY PRACTICES.

SE RECOMIENDA LEER Y ENTENDER LAS INSTRUCCIONES DEL FABRICANTE PARA EL USO DE ESTE EQUIPO Y LOS CONSUMIBLES QUE VA A UTILIZAR, SIGA LAS MEDIDAS DE SEGURIDAD DE SU SUPERVISOR.

LISEZ ET COMPRENEZ LES INSTRUCTIONS DU FABRICANT EN CE QUI REGARDE CET EQUIPMENT ET LES PRODUITS A ETRE EMPLOYES ET SUIVEZ LES PROCEDURES DE SECURITE DE VOTRE EMPLOYEUR.

LESEN SIE UND BEFOLGEN SIE DIE BETRIEBSANLEITUNG DER ANLAGE UND DEN ELEKTRODENEINSATZ DES HERSTELLERS. DIE UNFALLVERHÜTUNGSVORSCHRIFTEN DES ARBEITGEBERS SIND EBENFALLS ZU BEACHTEN.

			
<ul style="list-style-type: none"> • Keep your head out of fumes. • Use ventilation or exhaust to remove fumes from breathing zone. 	<ul style="list-style-type: none"> • Turn power off before servicing. 	<ul style="list-style-type: none"> • Do not operate with panel open or guards off. 	WARNING
<ul style="list-style-type: none"> • Los humos fuera de la zona de respiración. • Mantenga la cabeza fuera de los humos. Utilice ventilación o aspiración para gases. 	<ul style="list-style-type: none"> • Desconectar el cable de alimentación de poder de la máquina antes de iniciar cualquier servicio. 	<ul style="list-style-type: none"> • No operar con panel abierto o guardas quitadas. 	Spanish AVISO DE PRECAUCION
<ul style="list-style-type: none"> • Gardez la tête à l'écart des fumées. • Utilisez un ventilateur ou un aspirateur pour ôter les fumées des zones de travail. 	<ul style="list-style-type: none"> • Débranchez le courant avant l'entretien. 	<ul style="list-style-type: none"> • N'opérez pas avec les panneaux ouverts ou avec les dispositifs de protection enlevés. 	French ATTENTION
<ul style="list-style-type: none"> • Vermeiden Sie das Einatmen von Schweißrauch! • Sorgen Sie für gute Be- und Entlüftung des Arbeitsplatzes! 	<ul style="list-style-type: none"> • Strom vor Wartungsarbeiten abschalten! (Netzstrom völlig öffnen; Maschine anhalten!) 	<ul style="list-style-type: none"> • Anlage nie ohne Schutzgehäuse oder Innenschutzverkleidung in Betrieb setzen! 	German WARNUNG
<ul style="list-style-type: none"> • Mantenha seu rosto da fumaça. • Use ventilação e exaustão para remover fumo da zona respiratória. 	<ul style="list-style-type: none"> • Não opere com as tampas removidas. • Desligue a corrente antes de fazer serviço. • Não toque as partes elétricas nuas. 	<ul style="list-style-type: none"> • Mantenha-se afastado das partes moventes. • Não opere com os painéis abertos ou guardas removidas. 	Portuguese ATENÇÃO
<ul style="list-style-type: none"> ● ヒュームから頭を離すようにして下さい。 ● 換気や排煙に十分留意して下さい。 	<ul style="list-style-type: none"> ● メンテナンス・サービスに取りかかる際には、まず電源スイッチを必ず切して下さい。 	<ul style="list-style-type: none"> ● パネルやカバーを取り外したままで機械操作をしないで下さい。 	Japanese 注意事項
<ul style="list-style-type: none"> ● 頭部遠離煙霧。 ● 在呼吸區使用通風或排風器除煙。 	<ul style="list-style-type: none"> ● 維修前切斷電源。 	<ul style="list-style-type: none"> ● 儀表板打開或沒有安全罩時不準作業。 	Chinese 警告
<ul style="list-style-type: none"> ● 얼굴로부터 용접가스를 멀리하십시오. ● 호흡지역으로부터 용접가스를 제거하기 위해 가스제거기나 통풍기를 사용하십시오. 	<ul style="list-style-type: none"> ● 보수전에 전원을 차단하십시오. 	<ul style="list-style-type: none"> ● 패널이 열린 상태로 작동치 마십시오. 	Korean 위험
<ul style="list-style-type: none"> ● بعد رأسك بعيداً عن الدخان. ● استعمل التهوية أو جهاز ضغط الدخان للخارج لكي تبعد الدخان عن المنطقة التي تنتفخ فيها. 	<ul style="list-style-type: none"> ● اقطع التيار الكهربائي قبل القيام بأية صيانة. 	<ul style="list-style-type: none"> ● لا تشغيل هذا الجهاز إذا كانت الاغطية الحديدية الواقية ليست عليه. 	Arabic تحذير

LEIA E COMPREENDA AS INSTRUÇÕES DO FABRICANTE PARA ESTE EQUIPAMENTO E AS PARTES DE USO, E SIGA AS PRÁTICAS DE SEGURANÇA DO EMPREGADOR.

使う機械や溶材のメーカーの指示書をよく読み、まず理解して下さい。そして貴社の安全規定に従って下さい。

請詳細閱讀並理解製造廠提供的說明以及應該使用的銀焊材料，並請遵守貴方的有關勞動保護規定。

이 제품에 동봉된 작업지침서를 숙지하시고 귀사의 작업자 안전수칙을 준수하시기 바랍니다.

اقرأ بتمعن وأفهم تعليمات المصنع المنتج لهذه المعدات والمواد قبل استعمالها واتباع تعليمات الوقاية لصاحب العمل.

YESWELDER[®]
www.yeswelder.com

WE ALWAYS STAND BEHIND IT

Toll Free (855) 937-4567