

# Owner's Manual & Assembly Guide



Model No.

- CLG66CC
- CLG66FG
- CLG66BG
- CLG66SG

## 6' x 6'

Nominal Size

**! caution**

**sharp edges** \*

Gloves must be worn at all times to reduce risk of injury!

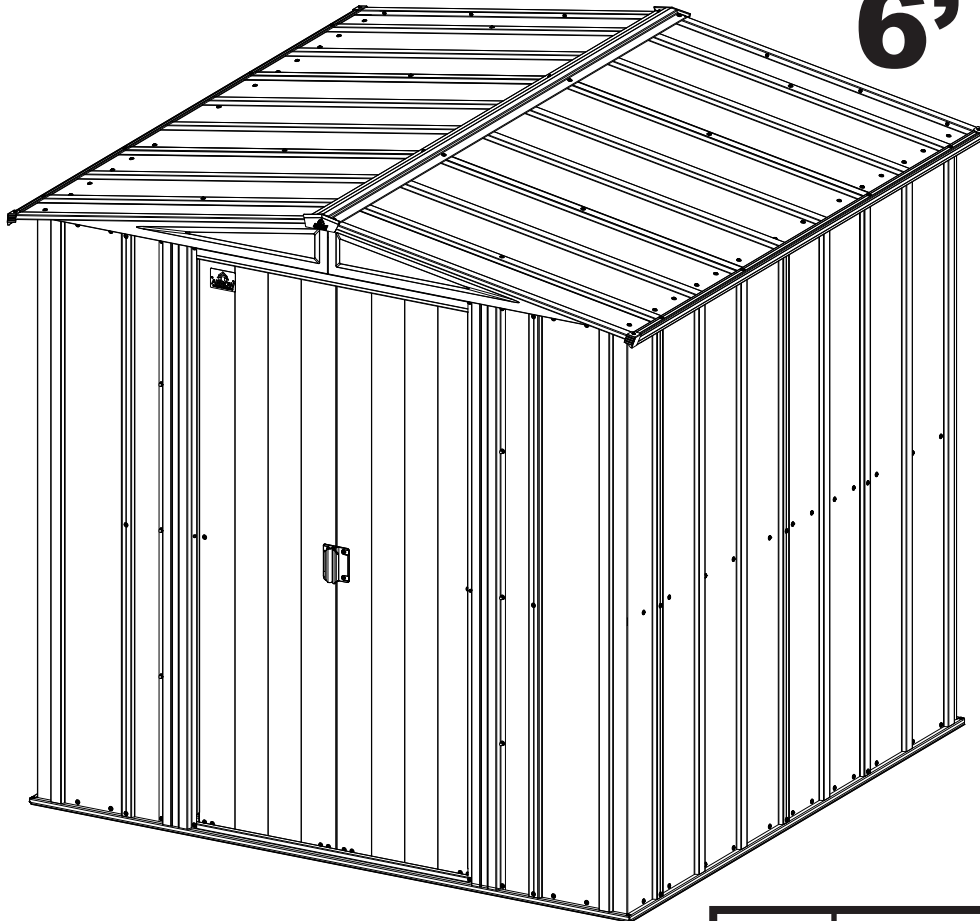

<b>Base Size</b>	74" x 71 5/8" 188,0 cm x 181,9 cm
------------------	--------------------------------------

### BUILDING DIMENSIONS

†Size rounded off to the nearest foot

For proper base construction see page 12

Approx.† Size	Storage Area		Exterior Dimensions (Roof Edge to Roof Edge)			Interior Dimensions (Wall to Wall)			Door Opening	
			Width	Depth	Height	Width	Depth	Height	Width	Height
6' x 6'	34 Sq. Ft.	195 Cu. Ft.	76 1/4"	74 1/8"	72 7/8"	71 1/4"	68 7/8"	71 5/8"	32"	63"
1,8 m x 1,8 m	3,2 m <sup>2</sup>	5,5 m <sup>3</sup>	193,7 cm	188,3 cm	185,1 cm	181,0 cm	174,9 cm	181,9 cm	81,3 cm	160,0 cm

\* See Inside for Detailed Safety Information.

# Manuel de l'utilisateur et guide d'assemblage



Taille de la base 74" x 71 5/8"  
188,0 cm x 181,9 cm

## DIMENSIONS DU COFFRE

† Dimension arrondie au pied le plus proche

Taille † approx.	Zone d'entreposage		Dimensions extérieures (de bordure de toit à bordure de toit)			Dimensions intérieures (de paroi à paroi)			Ouverture de porte	
			Largeur	Profondeur	Hauteur	Largeur	Profondeur	Hauteur	Largeur	Hauteur
6' x 6'	34 Sq. Ft.	195 Cu. Ft.	76 1/4"	74 1/8"	72 7/8"	71 1/4"	68 7/8"	71 5/8"	32"	63"
1,8 m x 1,8 m	3,2 m <sup>2</sup>	5,5 m <sup>3</sup>	193,7 cm	188,3 cm	185,1 cm	181,0 cm	174,9 cm	181,9 cm	81,3 cm	160,0 cm

\* Voir les informations de sécurité détaillées à l'intérieur.

# Manual del propietario e instrucciones de ensamblaje



Tamaño básico 74" x 71 5/8"  
188,0 cm x 181,9 cm

## DIMENSIONES DE LA UNIDAD

† Las medidas están redondeadas en pies

Tamaño † aproximado	Área de almacenaje		Dimensiones exteriores (borde a borde del techo)			Dimensiones interiores (pared a pared)			Abertura de la puerta	
			Ancho	Profundidad	Altura	Ancho	Profundidad	Altura	Ancho	Altura
6' x 6'	34 Sq. Ft.	195 Cu. Ft.	76 1/4"	74 1/8"	72 7/8"	71 1/4"	68 7/8"	71 5/8"	32"	63"
1,8 m x 1,8 m	3,2 m <sup>2</sup>	5,5 m <sup>3</sup>	193,7 cm	188,3 cm	185,1 cm	181,0 cm	174,9 cm	181,9 cm	81,3 cm	160,0 cm

\* Consulte en el interior para obtener la seguridad de información detallada.

# Pflege- & Montageanleitung



Bodenabmessungen 74" x 71 5/8"  
188,0 cm x 181,9 cm

## ABMESSUNGEN

† Angaben auf ganze Fuß gerundet

Ungefähre † Größe	Lagerfläche		Außenabmessungen (Dachkante zu Dachkante)			Innenabmessungen (Wand zu Wand)			Türöffnung	
			Breite	Tiefe	Höhe	Breite	Tiefe	Höhe	Breite	Höhe
6' x 6'	34 Sq. Ft.	195 Cu. Ft.	76 1/4"	74 1/8"	72 7/8"	71 1/4"	68 7/8"	71 5/8"	32"	63"
1,8 m x 1,8 m	3,2 m <sup>2</sup>	5,5 m <sup>3</sup>	193,7 cm	188,3 cm	185,1 cm	181,0 cm	174,9 cm	181,9 cm	81,3 cm	160,0 cm

\* Detaillierte Sicherheitsinformationen im Inneren.

## CAUTION / ATTENTION / PRECAUCIONES/ VORSICHT

EN,FR,SP,GE-04HN

- Care must be taken when handling various pieces of your building since many contain sharp edges.
- Faire preuve de précaution pour manipuler les différentes pièces de l'abri car elles présentent de nombreux bords coupants.
- Tenga cuidado al manipular las diferentes piezas de la estructura ya que pueden tener bordes filosos.
- Verschiedene Teile Ihres Schuppens müssen vorsichtig gehandhabt werden, denn viele haben scharfe Kanten.

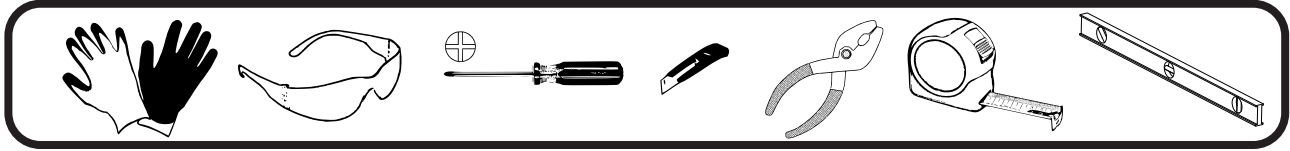

- Do NOT attempt to assemble your building before double checking that you have all the parts indicated in the parts lists. Any building left partially assembled may be seriously damaged by even light winds.
- Ne PAS tenter d'assembler l'abri avant d'avoir vérifié la présence de toutes les pièces figurant dans la liste des pièces. Tout abri laissé partiellement assemblé peut être gravement endommagé par des vents même légers.
- NO trate de montar la estructura antes de verificar que tenga todas las piezas indicadas en la lista de piezas. Cualquier estructura sin terminar puede ser dañada seriamente incluso por vientos ligeros.
- Versuchen Sie NICHT, Ihren Schuppen an einem windigen Tag aufzustellen. Die großen, flächigen Bauteile könnten wie ein Segel vom Wind erfasst und herumgeschleudert werden, was die Aufstellarbeiten erschwert und gefährlich macht.
- Do NOT attempt to assemble your building on a windy day. The large panels can catch the wind like a "sail", making construction difficult and unsafe. **Watch the Weather Closely**
- Ne PAS tenter d'assembler l'abri en présence de vent. Les grands panneaux peuvent se comporter comme une voile et « battre » au vent, rendant la construction difficile et dangereuse. **Suivre la météo avec attention**
- NO trate de montar la estructura en un día ventoso. Los paneles grandes pueden atrapar el viento como una "vela", lo que hace que sean llevados por el viento, lo que, a su vez, hace que la construcción sea difícil e insegura. **Observe el clima atentamente**
- Versuchen Sie NICHT, Ihren Schuppen zu montieren, bevor Sie sich nochmals vergewissert haben, dass Sie alle in der Teilleiste. Ein nur teilweise montiert zurückgelassener Schuppen kann bereits durch leichten Wind schwer beschädigt werden.
- Keep children and pets away from the worksite during construction and until the building is completely assembled. This will help avoid distractions and any accidents which may occur.
- Tenir les enfants et les animaux domestiques à l'écart du chantier durant la construction et jusqu'à ce que l'abri soit complètement assemblé. Cela évite les distractions et les accidents potentiels.
- No permita entrar a niños ni animales domésticos en el lugar de trabajo durante la construcción y hasta que la estructura esté completamente montada. Esto ayudará a evitar distracciones y cualquier accidente que pueda producirse.
- Halten Sie Kinder und Haustiere während der Montage und bis der Schuppen vollständig aufgestellt ist vom Aufstellplatz fern. Dies hilft, Ablenkungen und damit einhergehende Unfälle zu verhindern.
- NEVER concentrate your weight on the roof of the building.
- NE JAMAIS concentrer son propre poids sur le toit de l'abri.
- NUNCA concentre su peso en el techo de la estructura.
- Belasten Sie das Dach des Schuppens NIEMALS punktuell mit Ihrem Gewicht.
- Before assembling any parts, your base should be constructed and an anchoring system should be ready to use. Your building MUST be anchored to prevent wind damage.
- Avant de commencer à assembler des pièces, la base doit avoir été construite et le système d'ancrage doit être prêt à l'emploi. L'abri doit IMPÉRATIVEMENT être ancré pour éviter les dommages par le vent.
- Antes de montar cualquier pieza, debe estar construida la base y preparado el sistema de anclaje. La estructura DEBE estar anclada para evitar daños por vientos.
- Das Fundament sollte vor dem Zusammenbau der Teile gebaut und das Verankerungssystem nutzungsbereit sein. Ihr Schuppen MUSS verankert werden, um Schäden durch Wind zu verhindern.





- The best location is a level area with good drainage.
- Le meilleur emplacement sera une surface de niveau à bon drainage.
- El mejor lugar es un área nivelada con buen drenaje.
- Der bestmögliche Bauplatz ist eben mit einer guten Drainage.
- Allow enough space outside the building to be able to access the roof with a ladder.
- Laissez suffisamment d'espace à l'extérieur du bâtiment pour être en mesure d'accéder à la toiture avec une échelle.
- Deje suficiente espacio afuera del edificio para poder tener acceso al techo con una escalera.
- Es muß außerdem genügend Platz außerhalb des Gerätehauses vorgesehen werden, damit die Blechschrauben von außen aus verschraubt werden können.
- **Use Teamwork:** Two or more people are required to assemble your building.
- **Travailler en équipe:** Deux personnes ou plus sont nécessaires pour assembler l'abri.
- **Trabaje en equipo:** Se necesitan dos o más personas para ensamblar su cobertizo.
- **Arbeiten Sie im Team:** Mindestens zwei Personen werden für die Montage des Gerätehauses benötigt.

**CARE & MAINTENANCE / SOINS ET ENTRETIEN / PROTECCIÓN Y CONSERVACIÓN/  
PFLEGE & INSTANDHALTUNG**

- DO NOT use power washing to clean your shed.
- NE PAS utiliser de jet sous haute pression pour nettoyer l'abri.
- NO utilice hidrolavadora para limpiar el cobertizo.
- Reinigen Sie Ihren Schuppen NICHT mit dem Hochdruckreiniger.
- Combustibles and corrosives must be stored in air tight containers designed for chemical and/or combustible storage. Corrosive chemicals such as fertilizers, pesticides and herbicides should be cleaned off the interior and exterior surfaces immediately. Rust caused by chemical damage is not covered by the warranty.
- Les matières combustibles et corrosives doivent être entreposées dans des contenants étanches à l'air conçus pour l'entreposage de produits chimique et/ou combustibles. Les produits chimiques corrosifs tels que les engrais, pesticides et herbicides doivent immédiatement être nettoyés des surfaces intérieures et extérieures. La rouille causée par des produits chimiques n'est pas couverte par la garantie.
- Los combustibles y productos corrosivos deben guardarse en contenedores herméticos diseñados para almacenamiento de químicos o combustibles. Se deben limpiar inmediatamente los químicos corrosivos, como fertilizantes, pesticidas y herbicidas, de las superficies interiores y exteriores. El óxido causado por daños químicos no está cubierto por la garantía.
- Brennbare und ätzende Stoffe müssen in luftdichten Behältern gelagert werden, die zur Lagerung von Chemikalien und/oder Brennstoffen vorgesehen sind. Ätzende Chemikalien wie z. B. Dünger, Insektenvernichter und Unkrautvernichter sollten sofort von den Innen- und Außenflächen abgewischt werden. Durch die Lagerung von Chemikalien entstandener Rost wird nicht von der Gewährleistung abgedeckt.

**Rust protection precautions / Des mesures de protection contre la rouille /  
Las precauciones de protección contra el óxido/ Rostschutzmaßnahmen**

- Avoid nicking or scraping the coating surface, inside and out.
- Éviter d'entailler ou de rayer le revêtement de surface, à l'intérieur comme à l'extérieur.
- Evite dañar o raspar la capa protectora, por dentro y por fuera.
- Vermeiden Sie es, die Oberflächenbeschichtung an der Innen- und Außenseite zu beschädigen oder zu verkratzen.
- Keep roof, base perimeter and door free of debris.
- Nettoyer le toit, le pourtour de la base et les rails de porte de tous débris.
- Mantenga el techo, el perímetro de la base y los rieles de la puerta sin desechos.
- Halten Sie das Dach, den Bodenbereich und die Türführungen stets frei von Verunreinigungen.
- Touch up scrapes or nicks and any area of visible rust as soon as possible.
- Retoucher les entailles et égratignures et toute surface de rouille visible dès que possible.
- Retoque las raspaduras o las muescas y cualquier área de todo óxido visible lo más pronto posible.
- Bessern Sie Kratzer oder Beschädigungen und alle Bereiche mit sichtbarem Rost so schnell wie möglich aus.

Key No. Rep. N.º de referencia Lfd. Nr.	Part No. Réf. pièce N.º de pieza Art.-Nr.	Part Description	Description de la pièce	Descripción de la pieza	Bezeichnung	Qty. Qté Cant. Menge	Part Views Profils de pièces Vistas desde un extremo Vor-handen
1	65103	Hex Nut (#8-32)	Écrou hexagonal (8-32)	Tuerca hexagonal (N.º 8-32)	Sechskantmutter (#8-32)	77	
2	65923	Small Bolt (#8-32 x 3/8) (10 mm)	Petit boulon (8-32 x 3/8) (10 mm)	Perno pequeño color arena (N.º 8-32 x 3/8) (10 mm)	Kleine Maschinenschraube (#8-32 x 3/8) (10 mm)	77	
3	65004	Small Screw (#8AB x 5/16) (8 mm)	Petite vis (8AB x 5/16) (8 mm)	Tornillo pequeño color arena (N.º 8AB x 5/16) (8 mm)	Kleine Blechschraube (#8AB x 5/16) (8 mm)	246	
4	65900	Black Screw (#10B x 1/2) (13 mm)	Vis noire (#10B x 1/2) (13 mm)	Tornillo negro (#10B x 1/2) (13 mm)	Schwarze Schrauben (#10B x 1/2) (13 mm)	8	
5	65109	Acorn Nut (#8-32)	Écrou borgne (#8-32)	Tuerca cupulada (#8-32)	Hutmutter (#8-32)	6	

The fasteners used in each step are shown actual size at the top of each page. If you are unsure which fastener to use, hold it up to the picture and use the one that matches.

Les éléments de visserie utilisés à chaque étape sont représentés en taille réelle en haut de chaque page. En cas de doute sur le type de visserie à utiliser, les placer sur l'image et utiliser celui qui correspond.

Los tornillos y pernos que se utilizan en cada paso se muestran en el tamaño real en la parte superior de cada página. Si no está seguro de qué tornillo o perno de usar, compárelo con la imagen y use el que coincida con ella.







Die in den jeweiligen Schritten verwendeten Verbindungselemente werden am oberen Seitenrand jeweils in tatsächlicher Größe gezeigt. Falls Sie unsicher sind, welches Verbindungselement Sie verwenden sollen, dann halten Sie es vor das Bild und verwenden Sie dasjenige, das passt.

# HARDWARE LIST

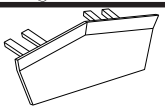
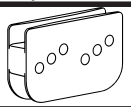
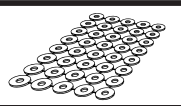
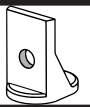
LISTE DE LA VISSERIE  
LISTA DE PIEZAS

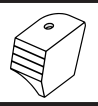
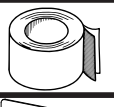
KLEINTEILELISTE













061R

Key No. Rep. N.º de referencia Lfd. Nr.	Part No. Réf. pièce N.º de pieza Art.-Nr.	Part Description	Description de la pièce	Descripción de la pieza	Bezeichnung	Qty. Qté Cant. Menge	Part Views Profils de pièces Vistas desde un extremo Vor-handen
6	66045	Handle / Poignée de porte / Manija de la puerta / Türgriff				2	
7	67468	Peak Cap / Embout de faîte / Tope del caballete / Firstkappe				2	
8	66769	Door Slide / Coulisseau de porte / Rodamiento de la puerta / Türgleiter				4	
9	66646	Washer Sheet / Plaque de rondelles / Plancha de arandelas / Unterlegscheiben				7	
10	66382	Lower Door Guide / Guide de porte inférieure / Guía inferior de la puerta / Untere Türführung				4	
11	66183L	Left Roof Trim Cap / Embout de garniture de toit gauche / Tope del contramarco del techo izquierdo / Eckabschluß link				2	
12	66183R	Right Roof Trim Cap / Embout de garniture de toit droit / Tope del contramarco del techo derecho / Eckabschluß recht				2	
13	67293	Weather Stripping / Ruban de calfeutrage / Burlete / Dichtungsband				1	
14	30028	Nameplate / Plaque signalétique / Placa de identificación / Typenschild				1	
15	66775	Plug (Door Jamb Color/Clear) / Bouchon (Couleur Jambage de porte/ Transparente) / Tapón (Color Jamba de la puerta/ Transparente) / Stopfen (Türpfosten Farbe / Klar)				2	
16	66775	Plug (Door Color) / Bouchon (Couleur de la porte) / Tapón (Color de la puerta) / Stopfen (Türfarbe)				2	

# PARTS LIST

LISTE DES PIÈCES  
ARTÍCULOS DE FERRETERÍA TEILELISTE

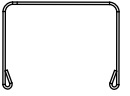

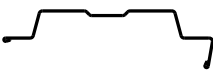







EN,FR,SP,GE-071R

Key No. Rep. N.º de referencia Lfd. Nr.	Part No. Réf. pièce N.º de pieza Art.-Nr.	Part Description	Description de la pièce	Descripción de la pieza	Bezeichnung	Qty. Qté Cant. Menge	Part Views Profils de pièces Vistas desde un extremo Vor-handen
17	11209	Side Floor Frame /	latéral Cadre de plancher / Tirante del entramado del piso lateral /	Seitenbodenrahmen		2	
18	9399	Rear Floor Frame /	Cadre de plancher arrière / Tirante del entramado trasero del piso /	Bodenrahmen hinten		1	
19	11523	Front Floor Frame /	Cadre de plancher avant / Tirante del entramado delantero del piso /	Bodenrahmen vorne		1	
20	11527	Corner Panel /	Panneau de coin / Panel esquinero /	Eckblech		2	
21	11521	Front Corner Panel /	Panneau de coin avant / Panel esquinero delantero /	Eckblech vorne		2	
22	11472	Wall Panel /	Panneau de mur / Panel de la pared /	Wandblech		2	
23	11473	Wall Panel /	Panneau de mur / Panel de la pared /	Wandblech		2	
24	11477	Wall Panel /	Panneau de mur / Panel de la pared /	Wandblech		2	
25	11524	Wall Panel /	Panneau de mur / Panel de la pared /	Wandblech		2	
26	9925	Rear Wall Channel /	Longeron de mur / Canaleta de la pared /	Rückwand verstrebung		1	
27	11216	Side Wall Channel /	Longeron de mur latéral / Canaleta de la pared lateral /	Seitenrückwand verstrebung		2	
28	11536	Side Wall Angle /	Cornière de mur latéral / Ángulo de la pared lateral /	Seitenwandwinkel		3	
29	9397	Rear Wall Angle /	Cornière arrière / Ángulo de la pared trasera /	Rückwandwinkel		1	
30	11479	Door Jamb /	Jambage de porte / Jamba de la puerta /	Türpfosten		2	

# PARTS LIST

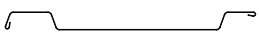
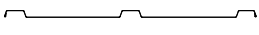
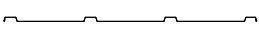
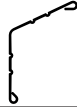
LISTE DES PIÈCES  
ARTÍCULOS DE FERRETERÍA TEILELISTE

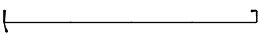
EN,FR,SP,GE-08IR



Key No. Rep. N.º de referencia Lfd. Nr.	Part No. Réf. pièce N.º de pieza Art.-Nr.	Part Description	Description de la pièce	Descripción de la pieza	Bezeichnung	Qty. Qté Cant. Menge	Part Views Profils de pièces Vistas desde un extremo Vor-handen
31	11522	Door Track / Rail de porte / Riel de la puerta / Türlaufschiene				1	
32	6658	Gable Brace / Renfort de pignon / Abrazadera del gablete / Giebelverstärkung				2	
33	5996	Right Gable / Pignon droit / Gablete derecho / Giebel rechts				2	
34	5997	Left Gable / Pignon gauche / Gablete izquierdo / Giebel links				2	
35	11537	Roof Beam / Poutre de toit / Viga del techo / Dachträger				1	
36	11538	Right Roof Panel / Panneau de toit droit / Panel del techo derecho / Dachblech rechts				2	
37	80267	Left Roof Panel / Panneau de toit gauche / Panel del techo izquierdo / Dachblech links				2	
38	11540	Roof Panel / Panneau de toit / Panel del techo / Dachblech				4	
39	11211	Roof Panel / Panneau de toit / Panel del techo / Dachblech				2	
40	11539	Roof Trim / Garniture de toit / Contramarco del techo / Dachabschlussleiste				2	
41	11213	Ridge Cap / Faîtage / Tope del caballete / Firstabdeckung				1	
42	80261	Door Panel / Panneau porte / Panel puerta / Tür				2	
43	6657	Door Handle Brace / Renfort de poignée de porte / Abrazadera de la manija de la puerta / Türgriffversteifung				2	



# PARTS LIST

LISTE DES PIÈCES  
ARTÍCULOS DE FERRETERÍA TEILELISTE

EN,FR,SP,GE-09IR

Key No. Rep. N.º de referencia Lfd. Nr.	Part No. Réf. pièce N.º de pieza Art.-Nr.	Part Description	Description de la pièce	Descripción de la pieza	Bezeichnung	Qty. Qté Cant. Menge	Part Views Profils de pièces Vistas desde un extremo Vor-handen
44	10499	Horizontal Door Brace / Renfort d'ouverture horizontale de la porte / Abrazadera de puerta horizontal / Horizontale Türschiene				4	
45	69836	Edge Trim(Purple) / Garniture de bordure (violet) / Contramarco del gablete de (morada) / Kantenschutz (Lila)				4	

# ASSEMBLY BY KEY NO.

PIÈCES PAR N° DE REPÈRE MONTAGE NACH LFD. NR.  
MONTAJE POR N.º DE REFERENCIA

101R

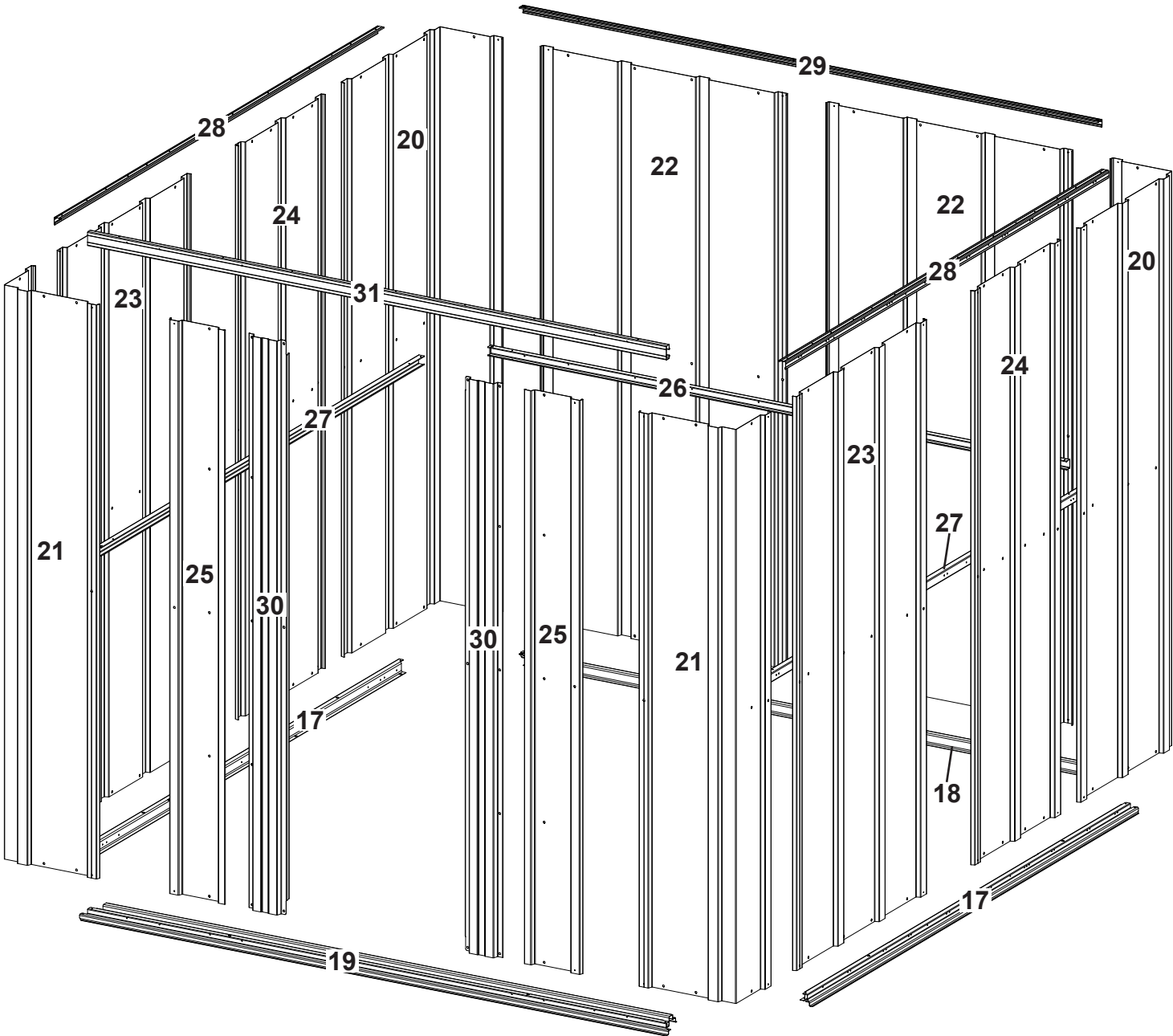

# ASSEMBLY BY KEY NO.

PIÈCES PAR N° DE REPÈRE MONTAGE NACH LFD. NR.  
MONTAJE POR N.º DE REFERENCIA

111R

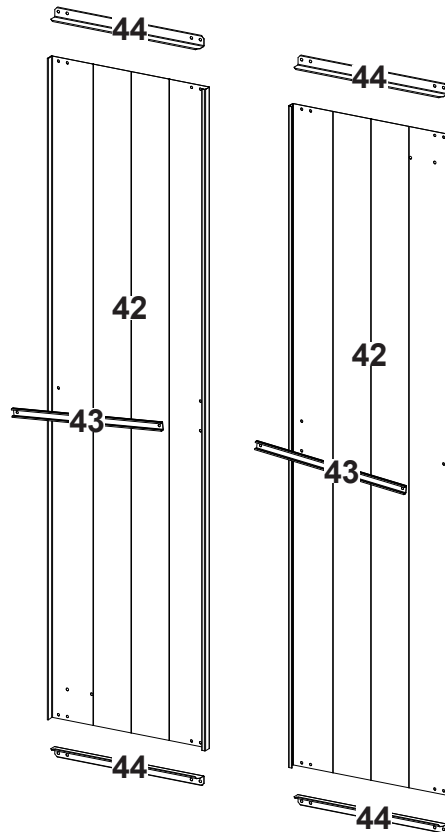
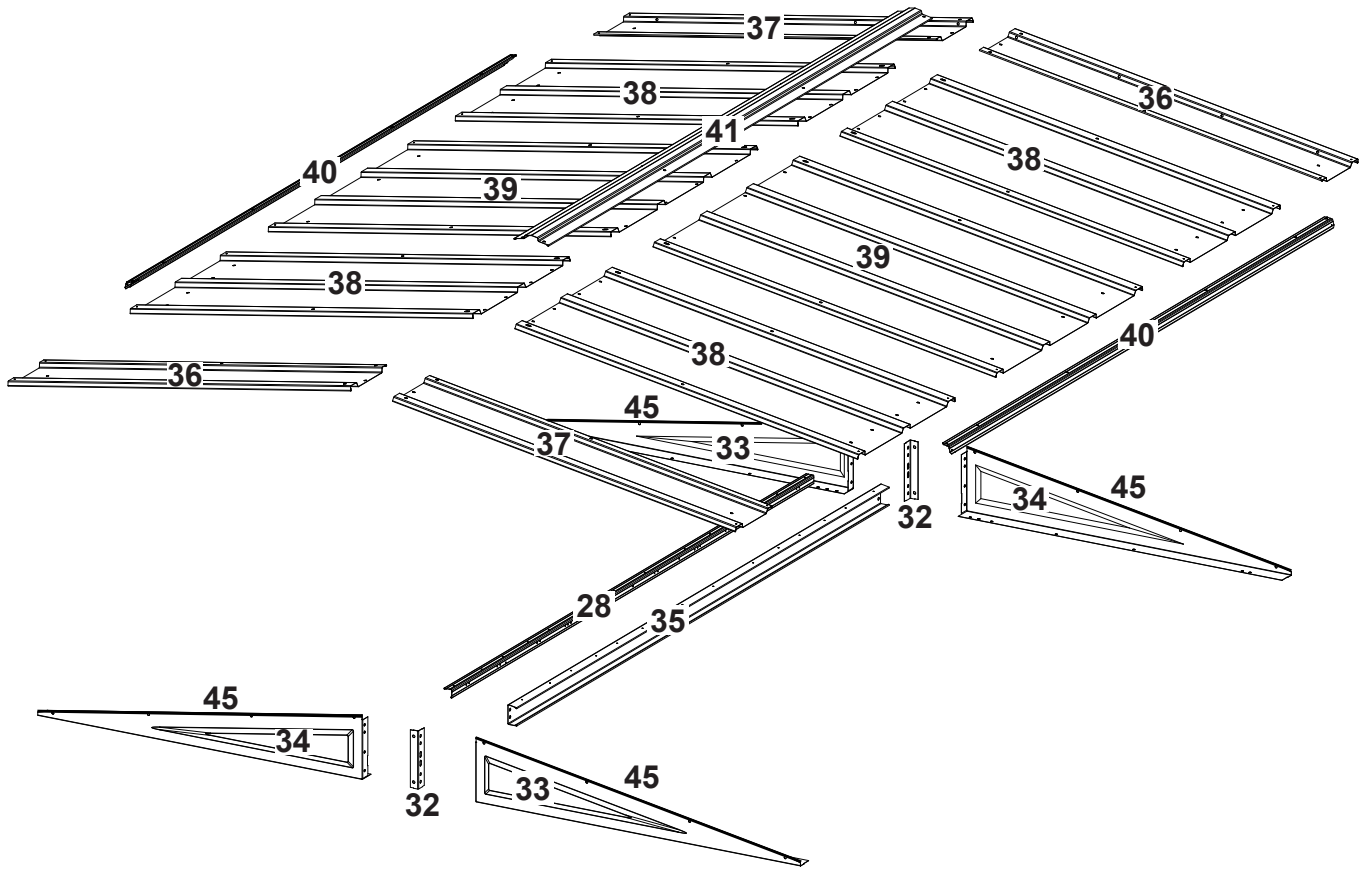

Wood Platform / Plateforme en bois

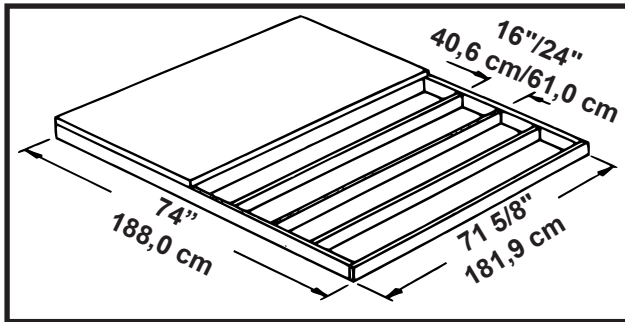

Concrete Slab / Dalle en béton

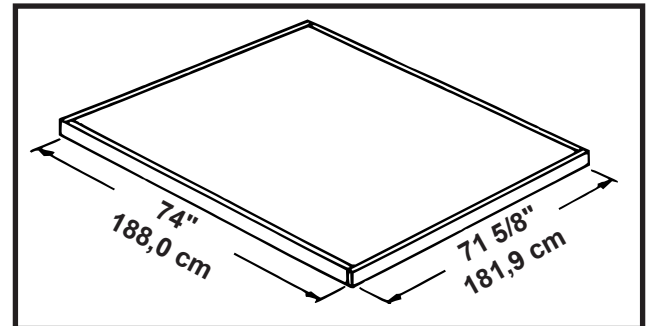

## \* IMPORTANT \*

The base **MUST** be flat and level to provide adequate support for your building, otherwise the **PRE-DRILLED HOLES WILL NOT ALIGN AND IT CANNOT BE ASSEMBLED**. No matter which of the options below you choose for a base, an **ARROW ANCHORING KIT** is recommended as an effective method of properly securing your building after assembly is complete.

### **OPTION 1: Build directly on the ground**

### **OPTION 2: Wood Platform**

**NOTE:** Pressure Treated Lumber must **NOT** be used where it will make contact with your storage building. The properties of Pressure Treated Lumber will cause accelerated corrosion. **If Pressure Treated Lumber comes in contact with your storage building your warranty will be voided.** The platform should be level and flat (free of bumps, ridges, etc.) to provide good support for the building. The necessary materials may be obtained from your local lumber yard.

### **OPTION 3: Concrete Slab**

The slab should be at least **4" (10,2 cm)** thick.

## \* IMPORTANT \*

La base **DOIT** être plate et de niveau pour fournir un support adéquat à votre bâtiment, sinon les trous **PRÉ-PERCÉS NE S'ALIGNERONT PAS ET ILS NE POURRONT PAS ÊTRE ASSEMBLÉS**. Quelque que soit l'option ci-dessous choisie pour la base, un **NÉCESSAIRE D'ANCRAGE ARROW** est recommandé pour amarrer solidement l'abri une fois que le montage est terminé.

### **OPTION 1 : Construire à même le sol**

### **OPTION 2 : Plateforme en bois**

**REMARQUE :** Ne **PAS** utiliser de bois traité sous pression aux points de contact avec l'abri. **Le bois traité sous pression contribue à accélérer la corrosion. Le contact de bois traité sous pression avec l'abri aura pour effet d'annuler la garantie.** La plateforme doit être plate et de niveau (sans bosses, arêtes, etc.) afin d'offrir un bon support à l'abri. Les matériaux nécessaires peuvent s'obtenir auprès d'un fournisseur de bois d'œuvre local.

### **OPTION 3 : Dalle en béton**

La dalle doit avoir au moins **4 "(10,2 cm)** d'épaisseur.

Plataforma de Madera / Plattform aus Holz

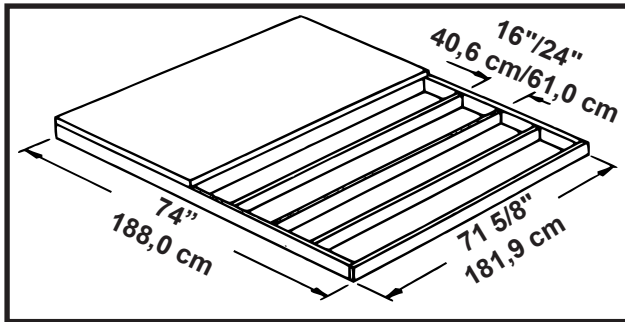

Losa de Hormigón / Bodenplatte aus Beton

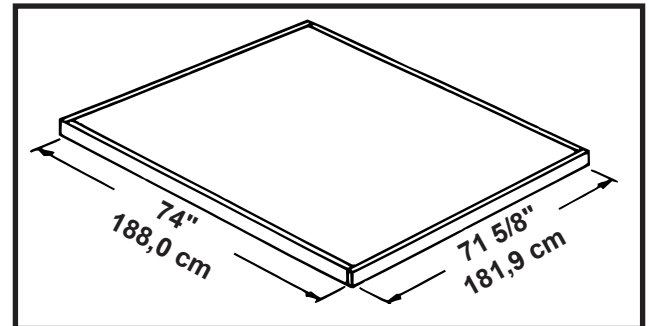

## \* IMPORTANTE \*

La base **DEBE** ser plana y nivelada para proporcionar el soporte adecuado para su edificio; de lo contrario, los **AGUJEROS PRETALADRADOS NO SE ALINEARÁN Y NO SE PUEDEN MONTAR**. Independientemente de las siguientes opciones que elija como base, se recomienda un KIT DE SUJECIÓN ARROW como método eficaz para sujetar adecuadamente su cobertizo después de terminar el ensamblaje.

### **OPCIÓN 1: Construir directamente en el suelo**

### **OPCIÓN 2: Plataforma de madera**

**NOTA:** La madera tratada a presión **NO** debe usarse donde haga contacto con su edificio de almacenamiento. Las propiedades de la madera tratada a presión causarán corrosión acelerada. **Si la madera tratada a presión entra en contacto con su edificio de almacenamiento, su garantía quedará anulada.** La plataforma debe estar nivelada y plana (libre de golpes, crestas, etc.) para proporcionar un buen soporte para el edificio. Los materiales necesarios se pueden obtener de su aserradero local.

### **OPCIÓN 3: Losa de hormigón**

La losa debe tener **al menos 4 "(10,2 cm)** de espesor.

## \*WICHTIG\*

Der Sockel **MUSS** flach und eben sein, um eine angemessene Unterstützung für Ihr Gebäude zu gewährleisten. Andernfalls werden die **VORGEBOHRTEN LÖCHER NICHT AUSGERICHTET UND ES KANN NICHT ZUSAMMENGEBAUT WERDEN**. Unabhängig davon, für welche der nachfolgend genannten Möglichkeiten Sie sich als Fundament entscheiden, empfiehlt sich ein ARROW-VERANKERUNGSKIT als wirkungsvolle Methode zur ordnungsgemäßen Sicherung Ihres Bauwerks nach Abschluss der Montagearbeiten.

### **MÖGLICHKEIT 1: Direkt auf dem Untergrund (Erde)**

### **MÖGLICHKEIT 2: Plattform aus Holz**

**HINWEIS:** An Stellen, an denen es mit Ihrem Geräteschuppen in Kontakt kommen würde, darf **kein** kesseldruckimprägniertes Holz verwendet werden. Kesseldruckimprägniertes Holz hat Eigenschaften, die zu beschleunigter Korrosion führen. **Wenn kesseldruckimprägniertes Holz mit Ihrem Geräteschuppen in Kontakt kommt, wird Ihre Garantie ungültig.**

### **MÖGLICHKEIT 3: Bodenplatte aus Beton**

Die Bodenplatte sollte **wenigstens 10,2 cm** stark sein.

# 1: FLOOR FRAME

CADRE DE PLANCHER  
MARCO DE PISO BODENRAHMEN

14IR

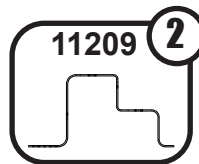
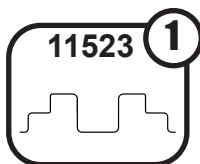
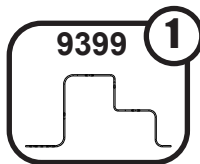
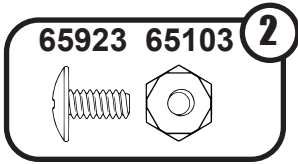
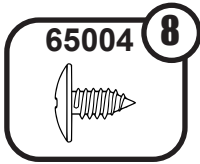

## NOTES:

Do NOT fasten your Floor Frames to your Base at this time. You will anchor your building after it is erected.

The Floor Frame must be BOTH square AND level or the holes will not line up properly.

Measure diagonally from corner to corner. When diagonal measurements are equal, the Frame is square.

## REMARQUES:

Ne PAS attacher les éléments de cadre de plancher à la base à ce stade. L'abri sera ancré une fois qu'il est assemblé.

Le cadre de plancher doit être À LA FOIS d'équerre et de niveau pour que les trous s'alignent correctement.

Mesurer en diagonale d'un coin à l'autre. Lorsqu'elles sont égales, le cadre de plancher est d'équerre.

## NOTAS:

NO fije los tirantes del piso a la base en este momento. Anclará la estructura después de que esté erguida.

El tirante del piso debe estar TANTO cuadrado COMO nivelado o los orificios no se alinearán correctamente.

Mida diagonalmente de esquina a esquina. Cuando las medidas diagonales son iguales, el tirante está cuadrado.

## HINWEIS:

Befestigen Sie Ihre Bodenrahmen noch NICHT am Fundament. Sie verankern Ihr Bauwerk erst, nachdem es fertig aufgebaut ist.

Der Bodenrahmen muss SOWOHL rechtwinklig ALS AUCH waagrecht sein. Andernfalls fluchten die Löcher nicht richtig.

Messen Sie diagonal von Ecke zu Ecke. Wenn die diagonalen Abmessungen gleich sind, ist der Rahmen rechtwinklig.

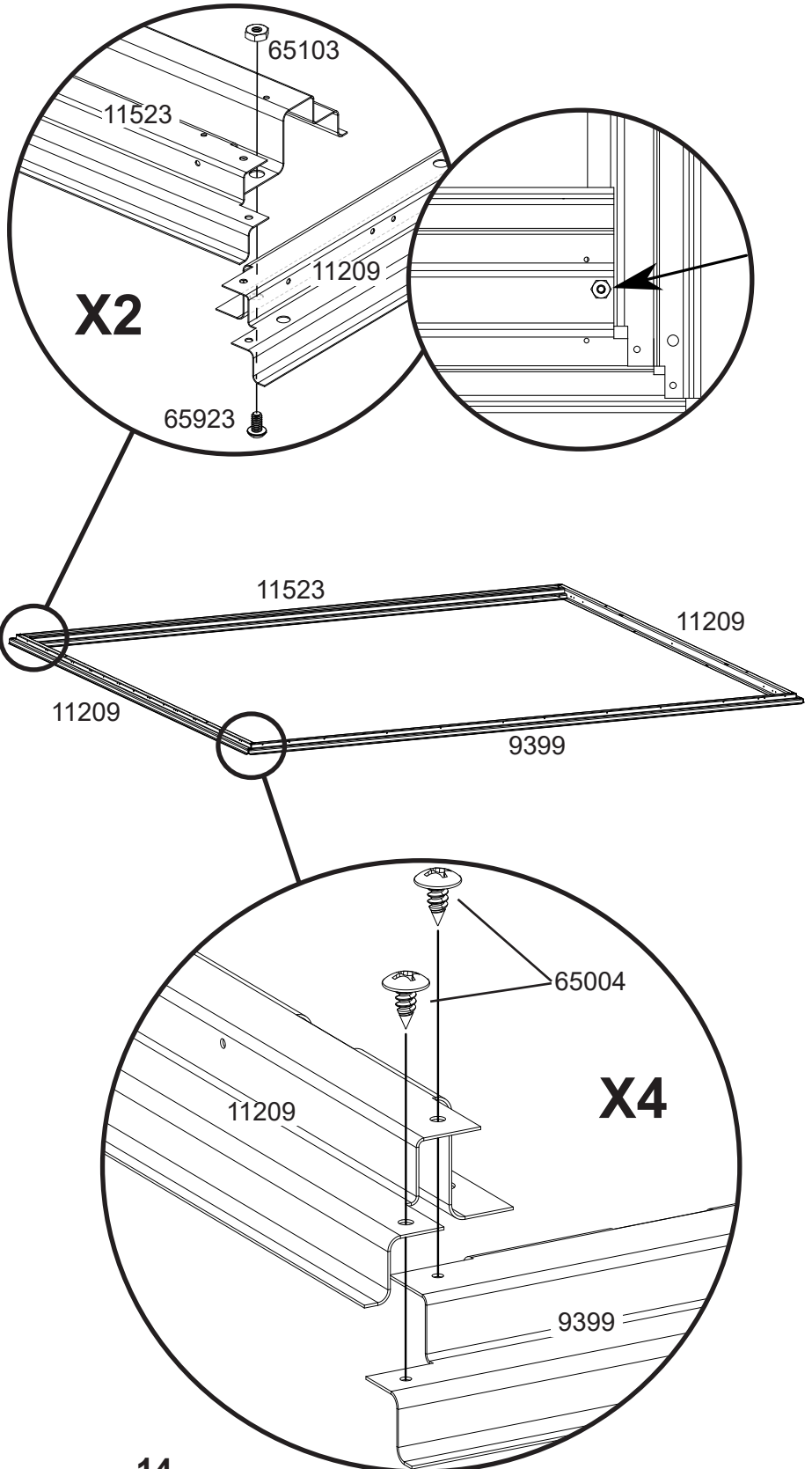

# 2: PRE-ASSEMBLY

PRÉ-ASSEMBLAGE  
PRE-ENSAMBLE VORMONTAGE

15IR

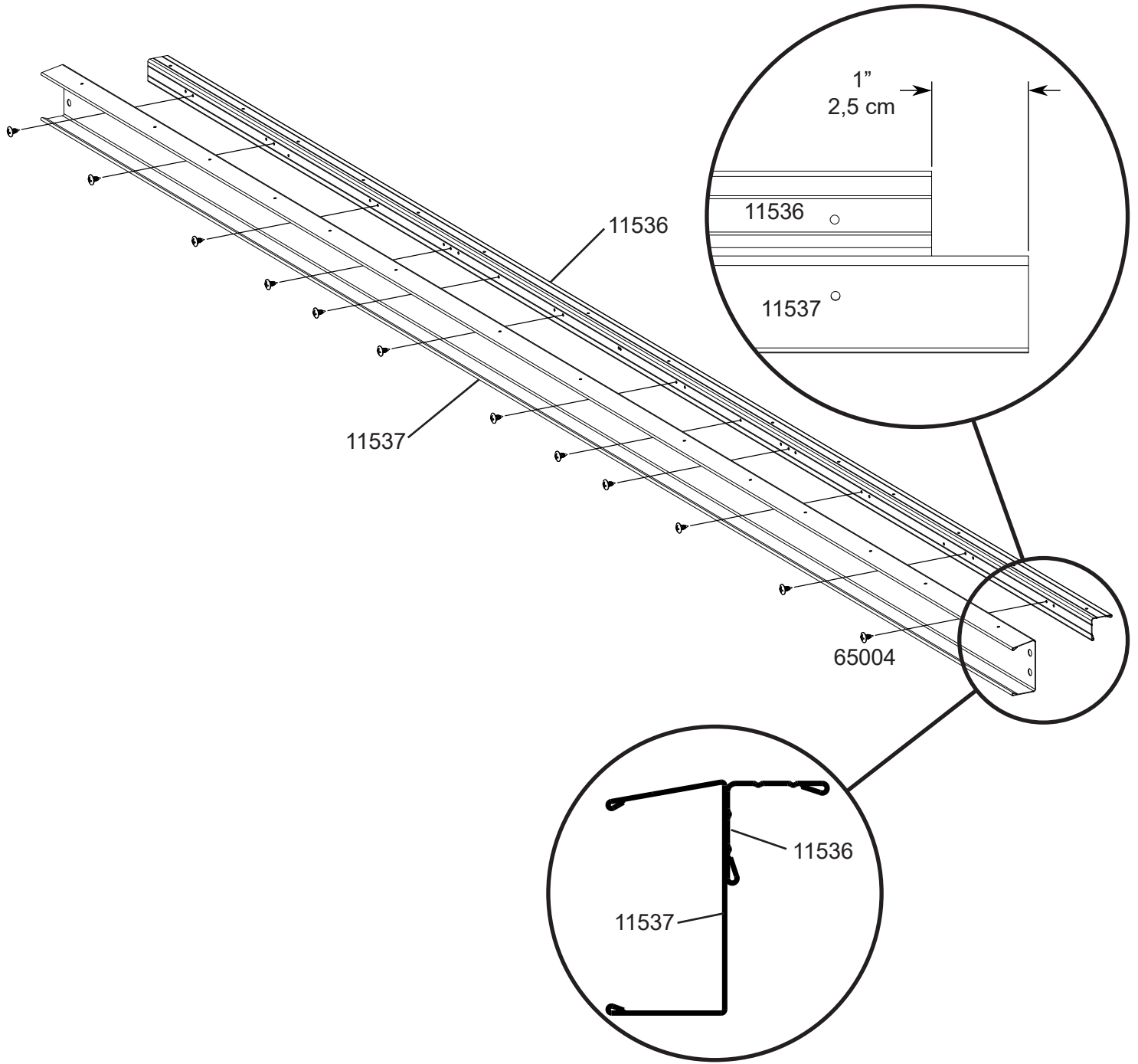
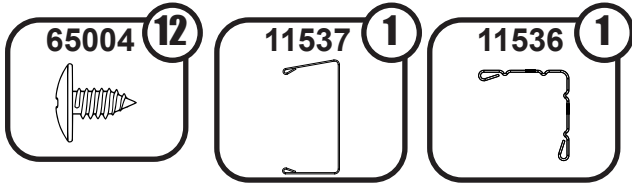

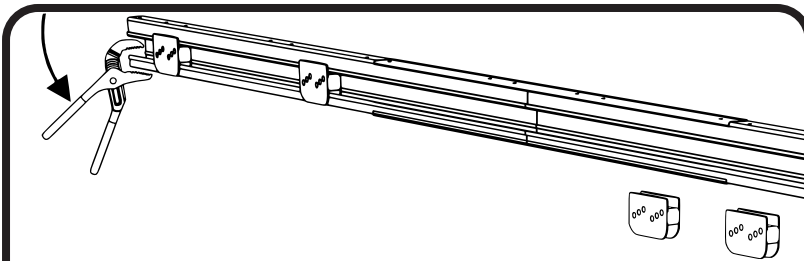
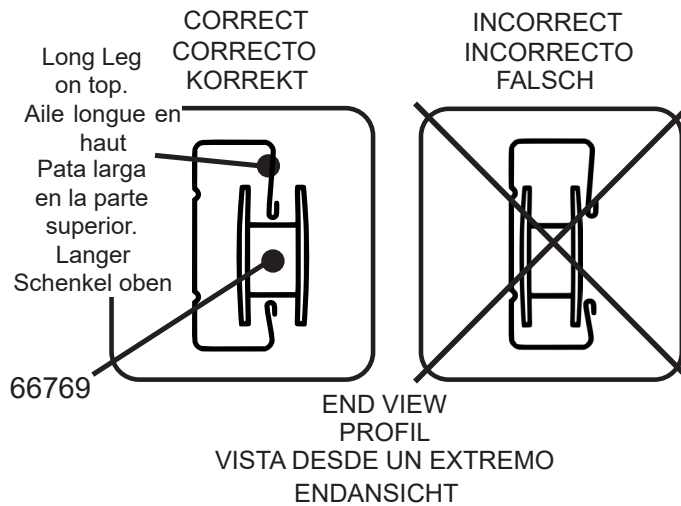
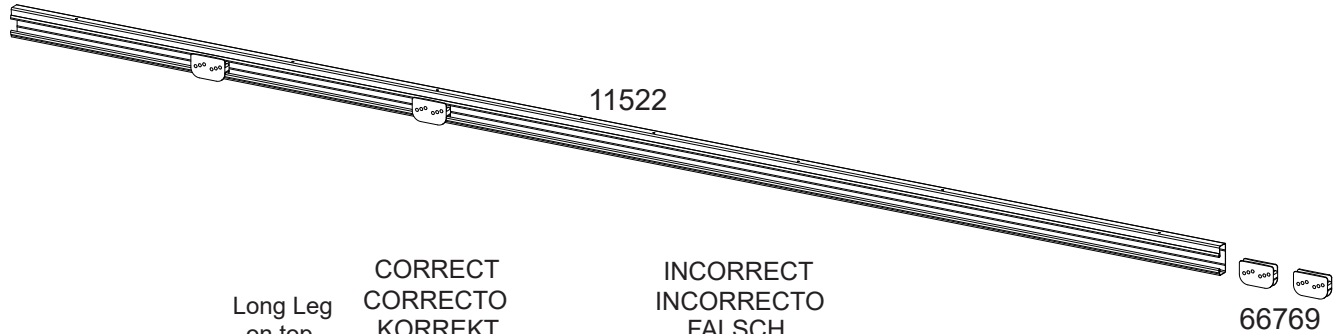
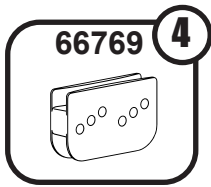
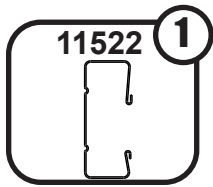

Slides should be installed in Door Track prior to installation. However, if this step is overlooked or if the Slides need to be removed for maintenance, the following procedure may be used.

Les coulisseaux doivent être placés dans le rail de porte avant la pose du rail. Toutefois, si cette étape est omise ou si les coulisseaux doivent être déposés à des fins d'entretien, la méthode suivante peut être utilisée.

Se deben instalar los rodamientos en el riel de la puerta antes de la instalación. Sin embargo, si se saltea este paso o si se deben extraer los rodamientos para mantenimiento, se debe realizar el siguiente procedimiento.

Die Schlitten sollten vor dem Einbau in der Türschiene montiert werden. Falls dieser Schritt ausgelassen wird oder die Schlitten für Wartungsarbeiten entfernt werden müssen, geht man wie folgt vor.

**To remove or install Door Slides:**

- Remove Doors from Slides and set aside.
- Using pliers, bend down a corner of the Door Track.
- Remove or install Door Slides.
- Carefully bend the corner back into position.

**Pour déposer ou poser les coulisseaux de porte :**

- Détacher les portes des coulisseaux et les mettre de côté.
- Avec une pince, rabattre un coin du rail de porte.
- Retirer ou enfiler les coulisseaux de porte.
- Avec précaution, remettre le coin du rail dans sa position d'origine.

**Para extraer o instalar los rodamientos de la puerta:**

- Saque las puertas de los rodamientos y sepárelas.
- Con un alicate, doble hacia abajo un ángulo del riel de la puerta.
- Saque o instale los rodamientos de la puerta.
- Con cuidado, doble el ángulo nuevamente a su posición.

**Türschlitten Entfernen oder Einbauen:**

- Türe der Schlitten entfernen und beiseite stellen.
- Mit einer Zange eine Ecke der Türschiene nach unten biegen.
- Türschlitten entfernen oder einbauen.
- Die Ecke vorsichtig zurück an ihren Platz biegen.



# 3: CORNER PANELS

PANNEAUX D'ANGLE  
PANELES DE ESQUINA ECKPLATTEN

171R

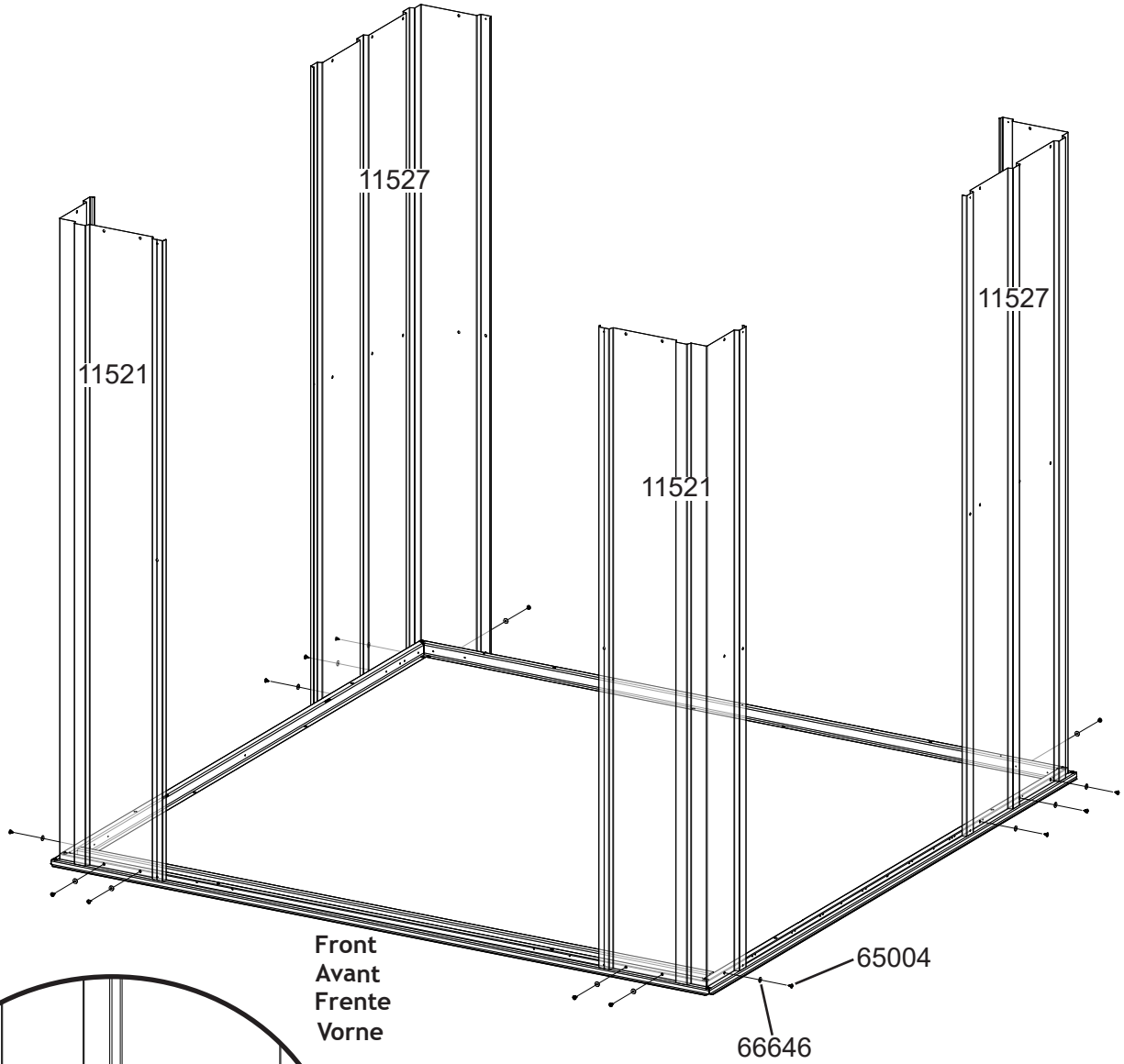
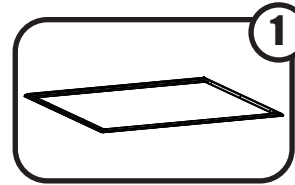
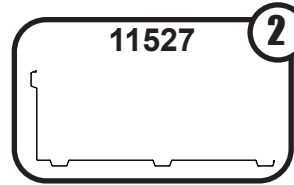
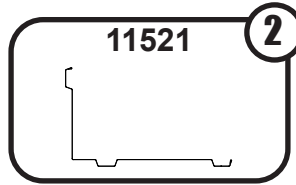
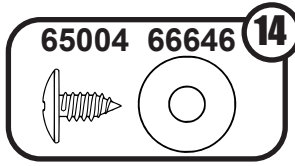

# 4: WALL ANGLE

CORNIÈRE DE MUR  
 ÁNGULO DE LA PARED WANDWINKEL

18IR

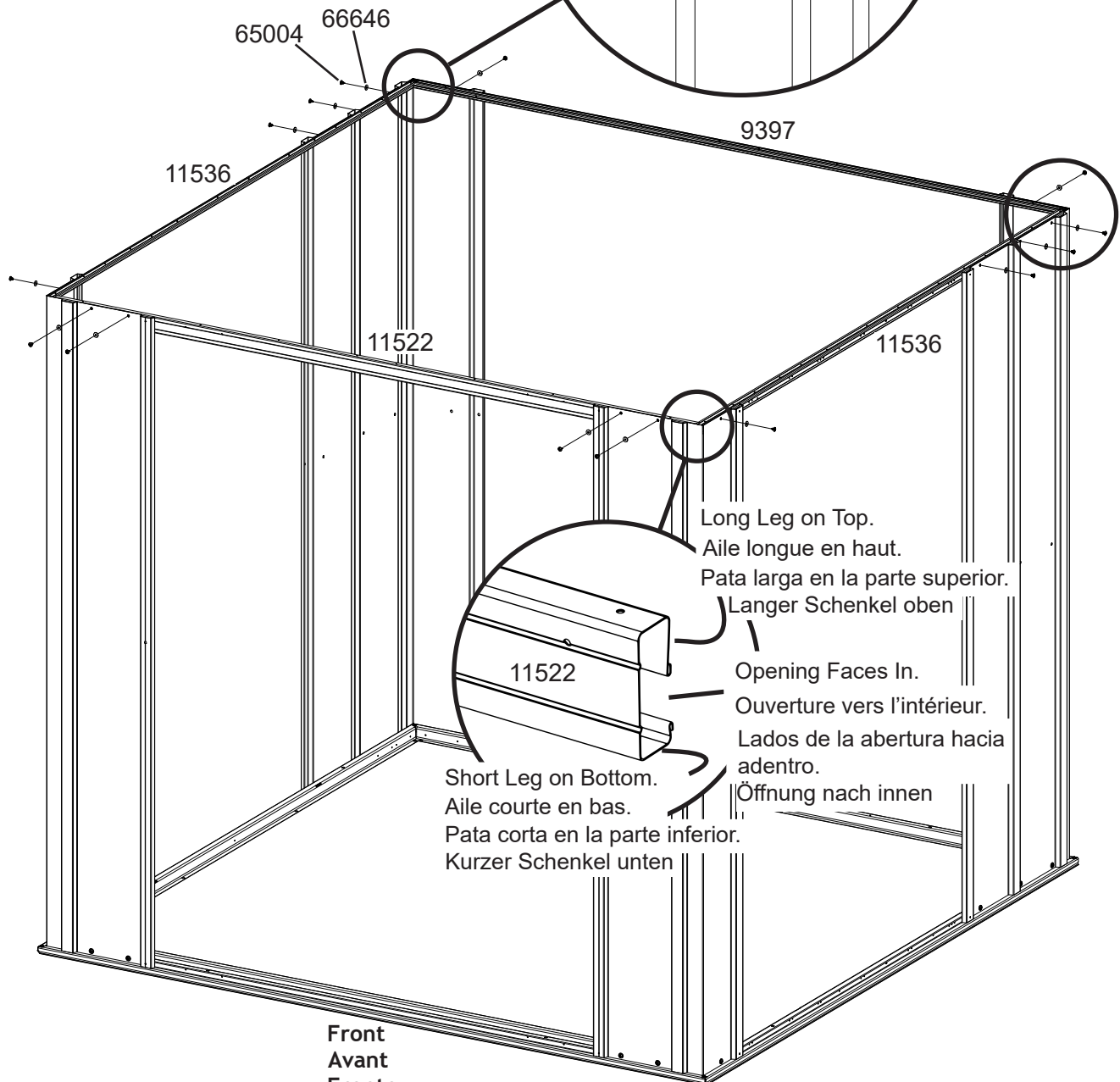
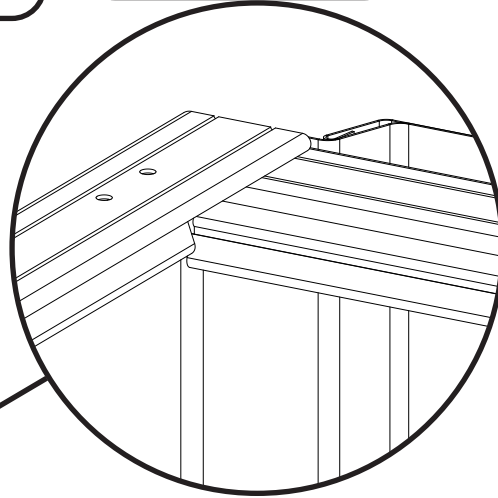
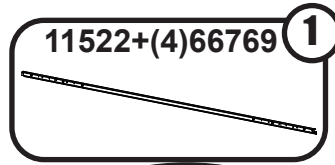
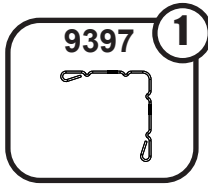
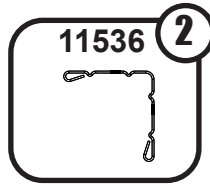
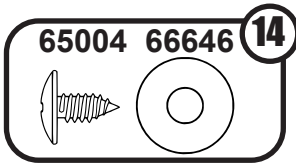

Long Leg on Top.  
 Aile longue en haut.  
 Pata larga en la parte superior.  
 Langer Schenkel oben

Opening Faces In.  
 Ouverture vers l'intérieur.  
 Lados de la abertura hacia adentro.  
 Öffnung nach innen

Short Leg on Bottom.  
 Aile courte en bas.  
 Pata corta en la parte inferior.  
 Kurzer Schenkel unten

Front  
 Avant  
 Frente  
 Vorne

# 5: WALL PANELS

PANNEAUX DE MUR  
PANELES DE LA PARED WANDBLECHE

19IR

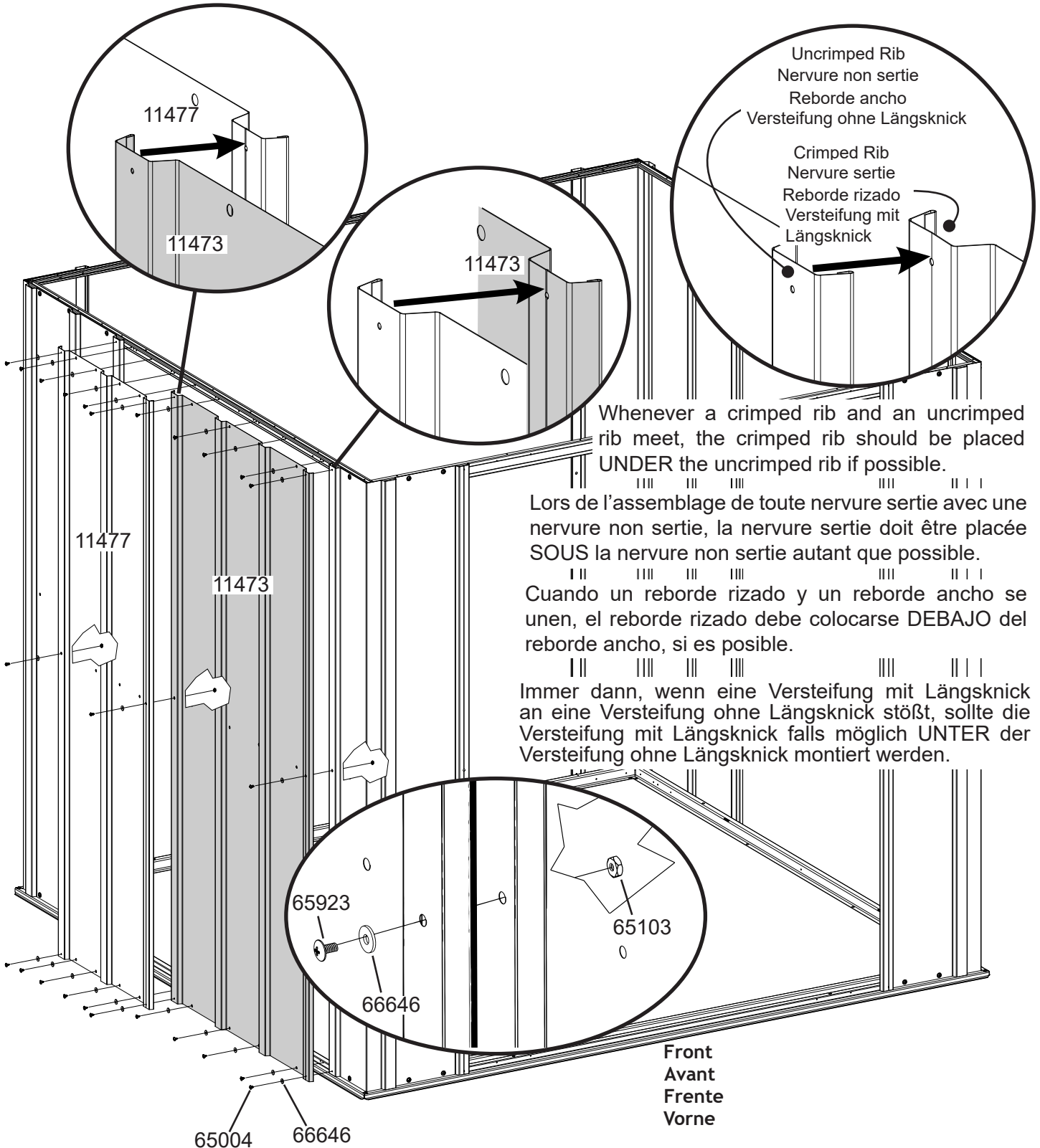
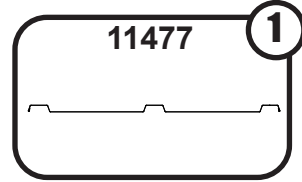
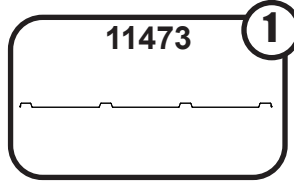
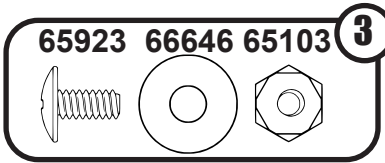
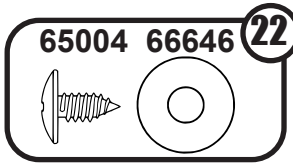

Whenever a crimped rib and an uncrimped rib meet, the crimped rib should be placed **UNDER** the uncrimped rib if possible.

Lors de l'assemblage de toute nervure sertie avec une nervure non sertie, la nervure sertie doit être placée **SOUS** la nervure non sertie autant que possible.

Quando un reborde rizado y un reborde ancho se unen, el reborde rizado debe colocarse **DEBAJO** del reborde ancho, si es posible.

Immer dann, wenn eine Versteifung mit Längsknick an eine Versteifung ohne Längsknick stößt, sollte die Versteifung mit Längsknick falls möglich **UNTER** der Versteifung ohne Längsknick montiert werden.

# 5: WALL PANELS

PANNEAUX DE MUR  
PANELES DE LA PARED WANDBLECHE

201R

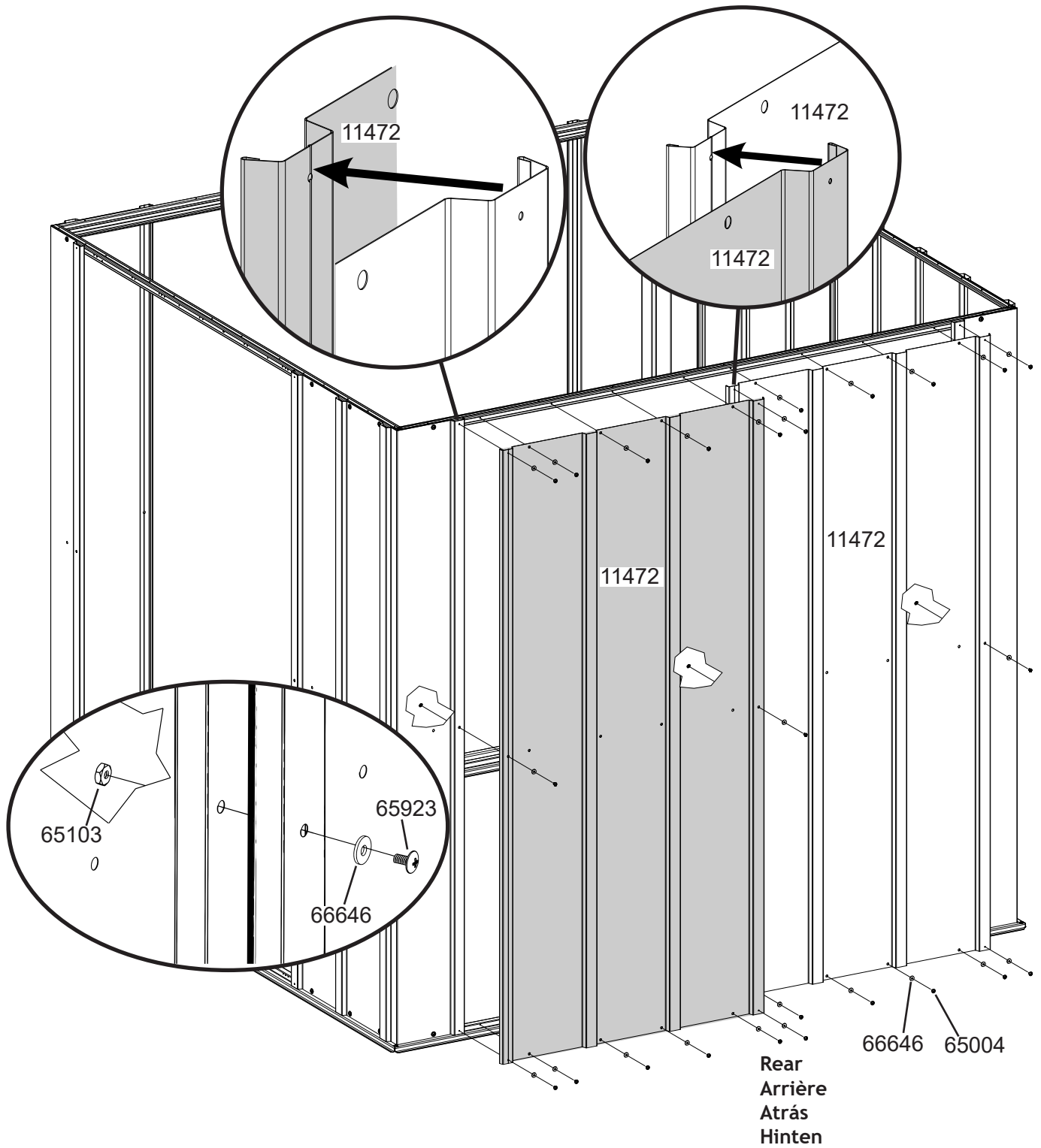
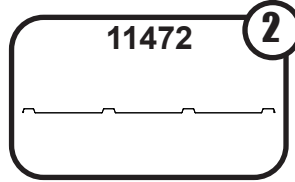
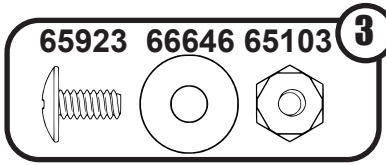
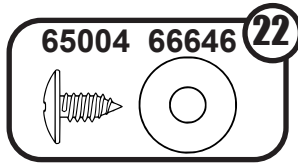

# 5: WALL PANELS

PANNEAUX DE MUR  
PANELES DE LA PARED WANDBLECHE

21IR

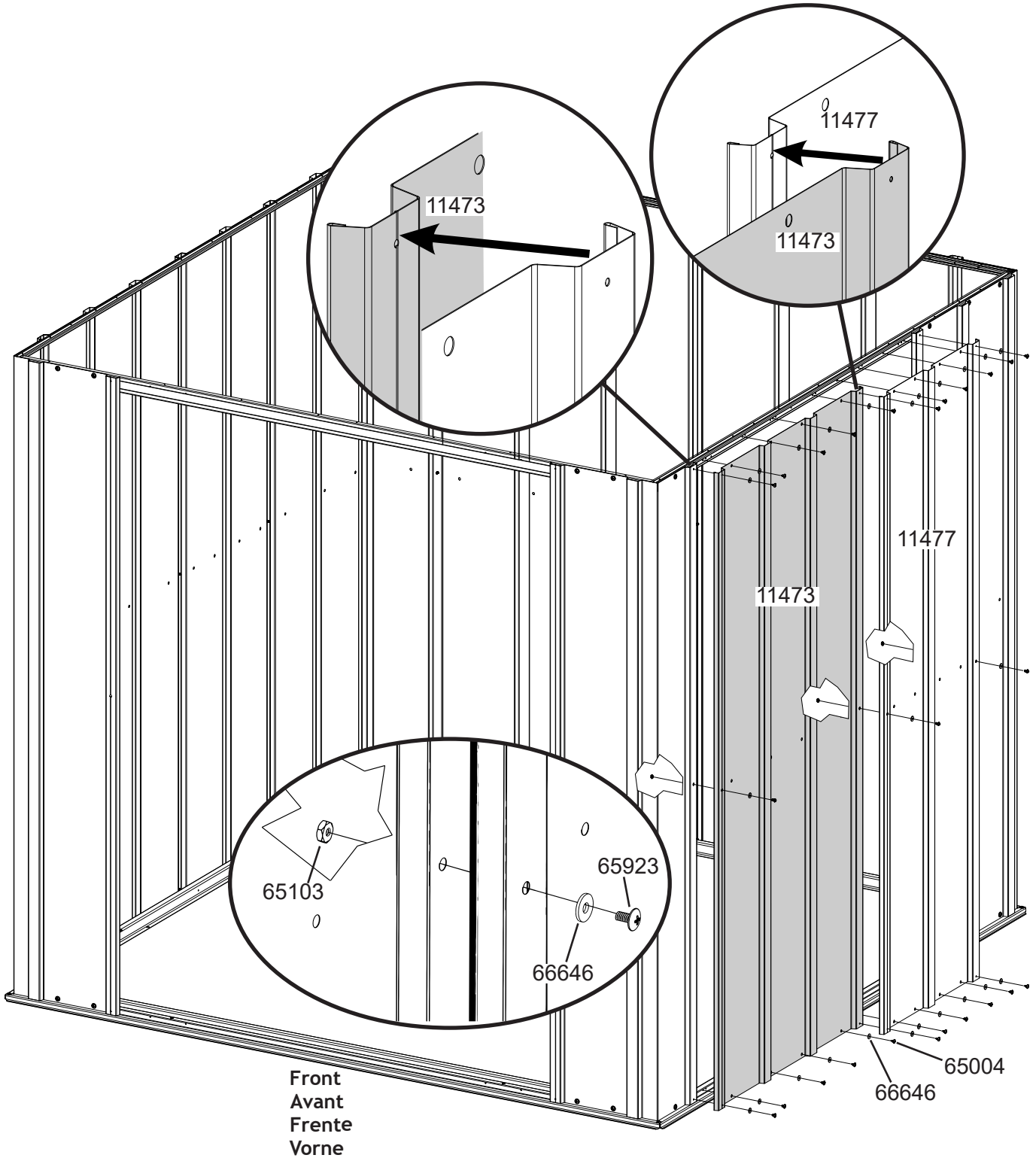
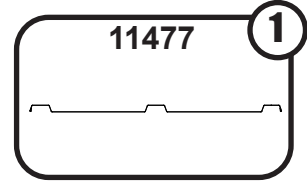
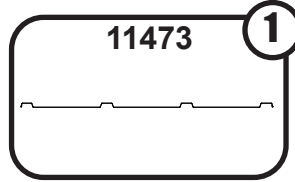
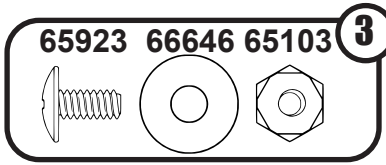
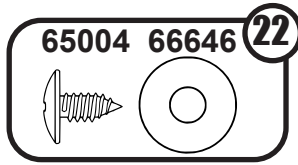

# 5: WALL PANELS

PANNEAUX DE MUR  
PANELES DE LA PARED WANDBLECHE

221R

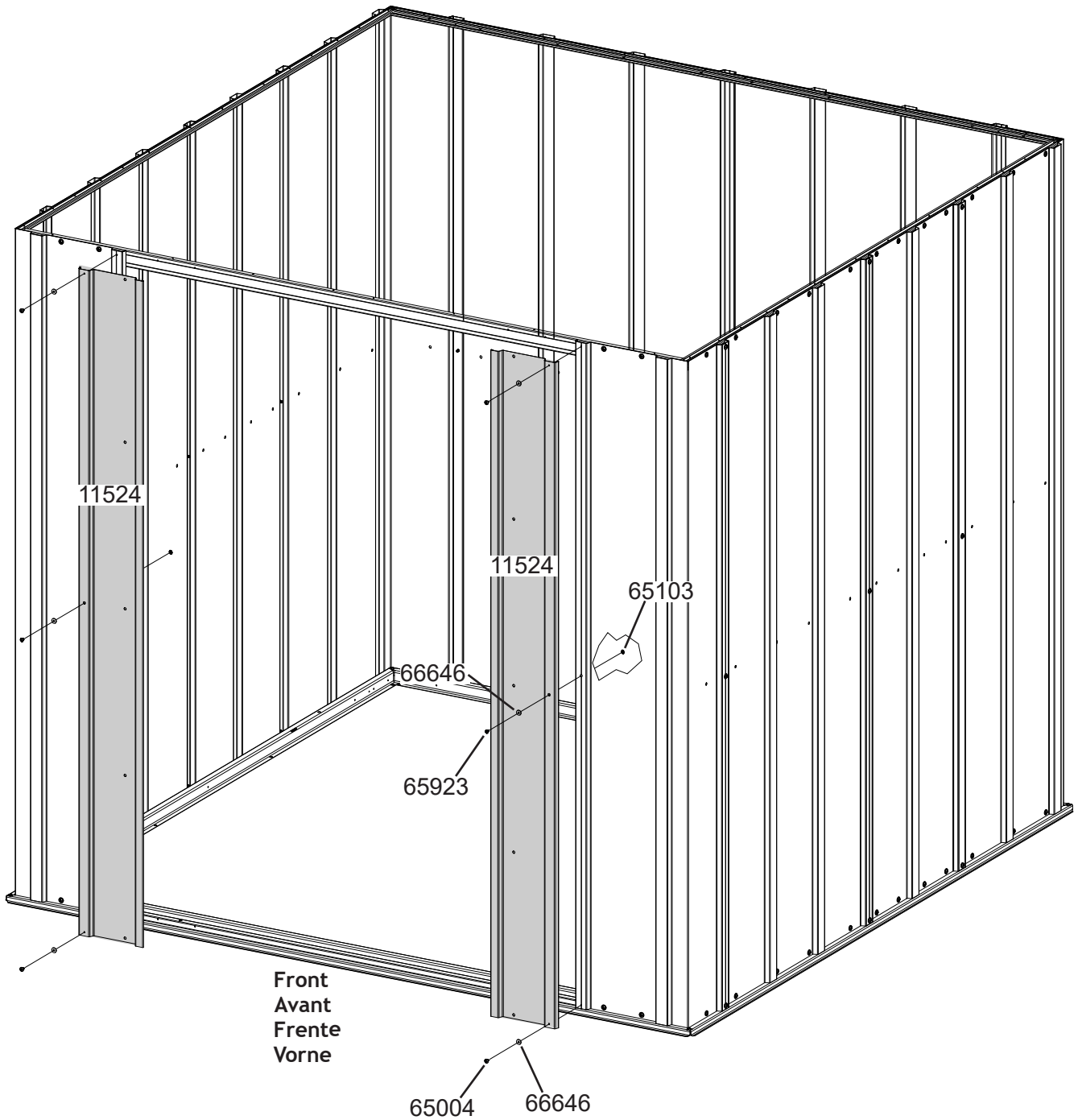
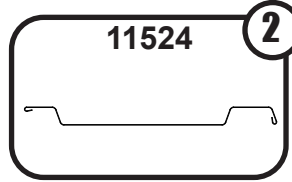
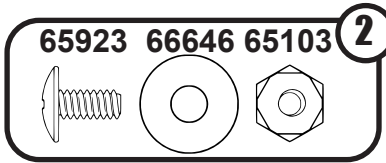
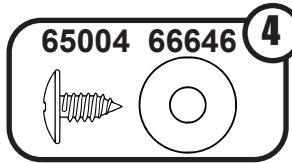

# 6: DOOR JAMB

JAMBAGE DE PORTE  
JAMBA DE LA PUERTA TÜRPFOSTEN

23IR

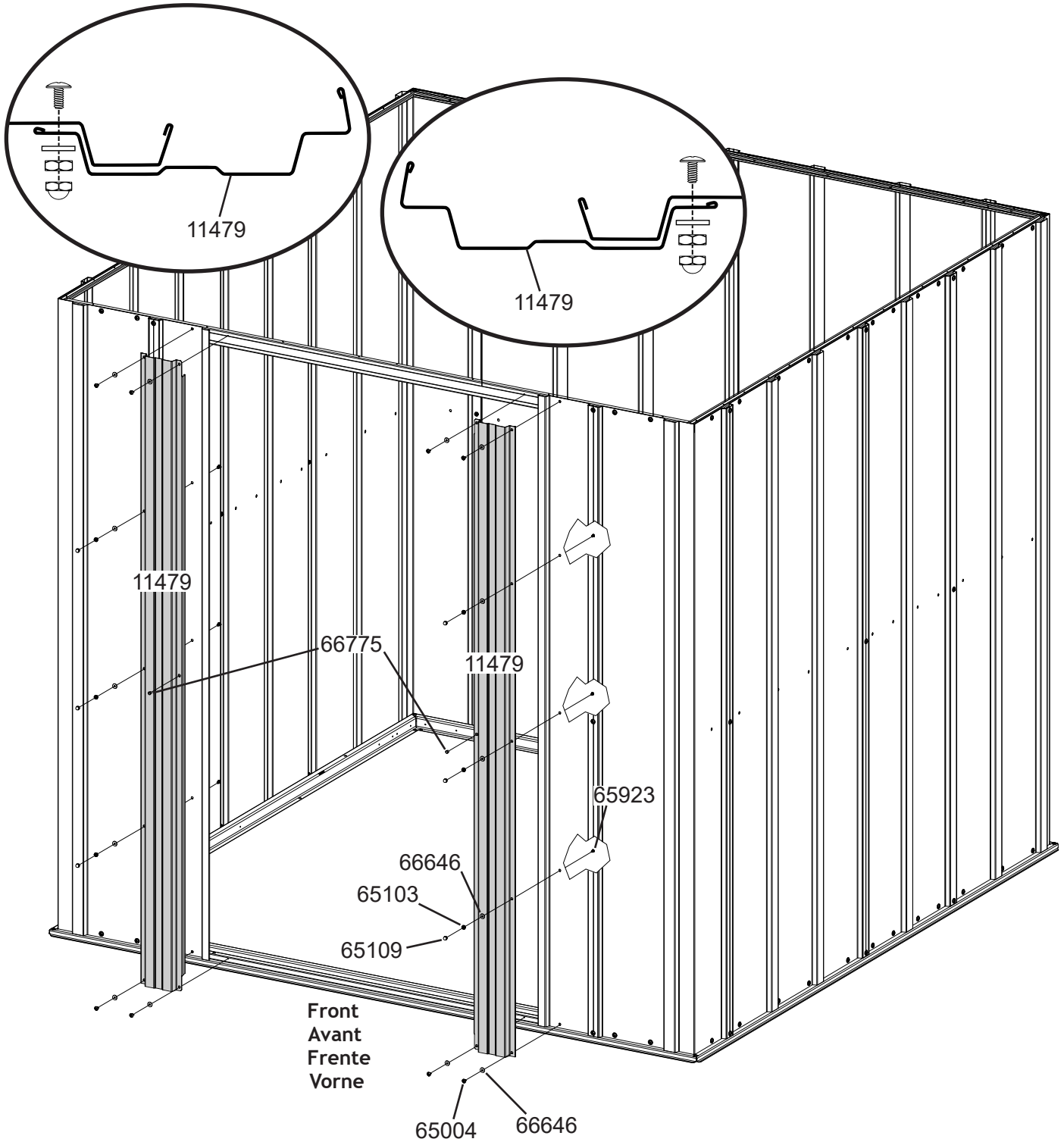
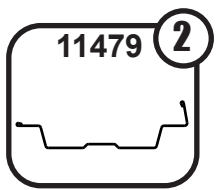
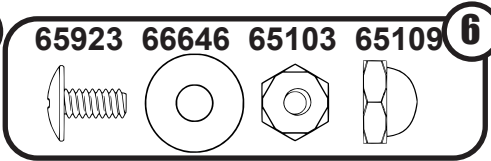
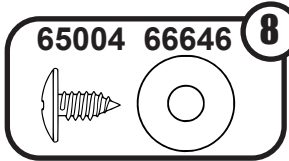

# 7: WALL CHANNEL

LONGERON DE MUR  
CANALETA DE LA PARED WAND VERSTREBUNG

24IR

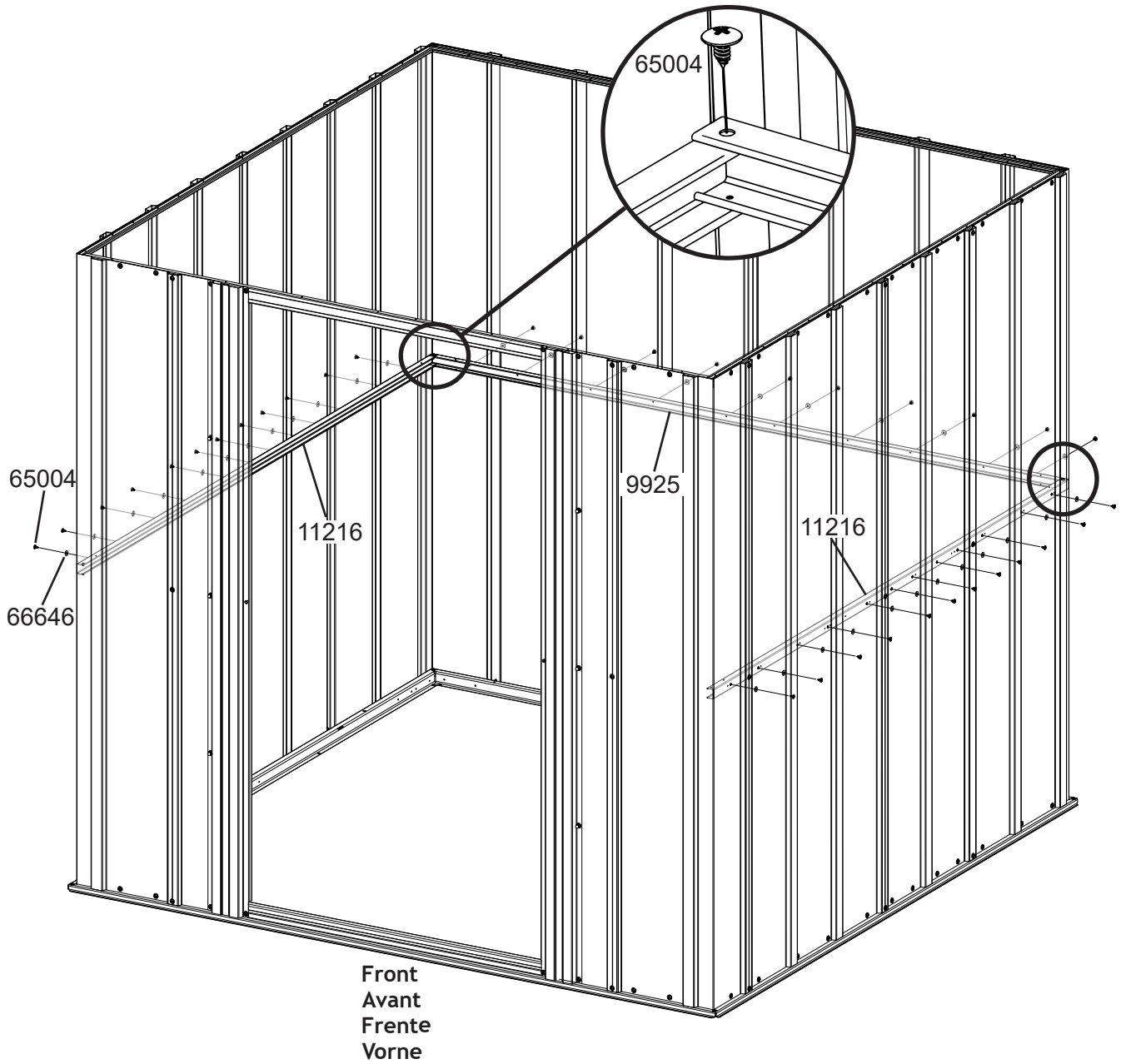
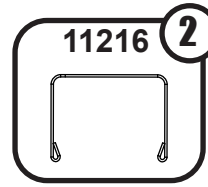
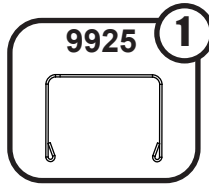
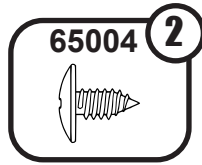
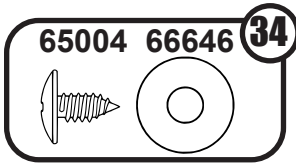



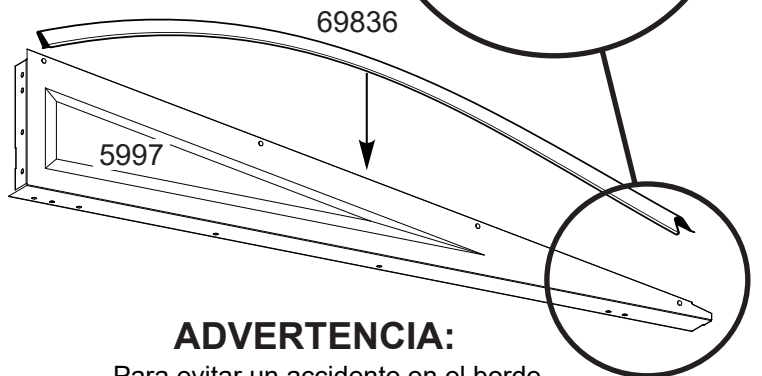
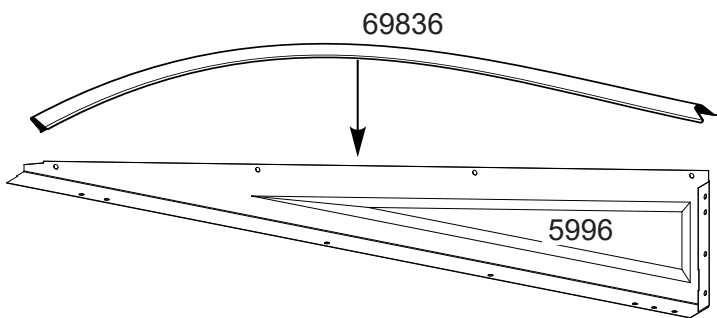
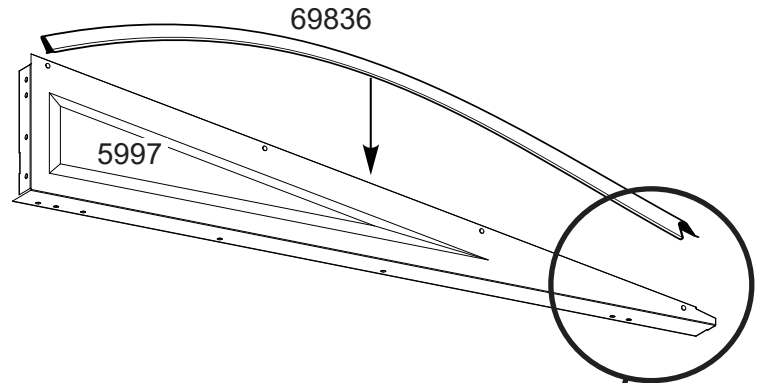
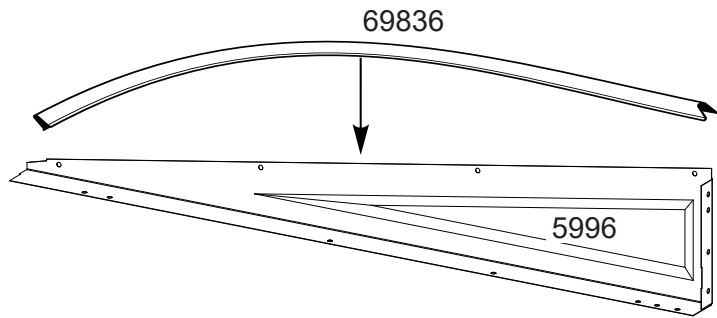
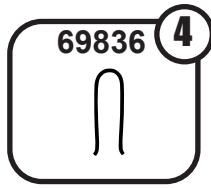
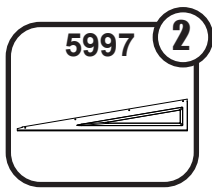
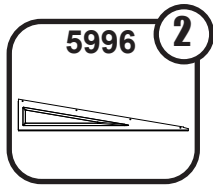

### CAUTION:

To avoid mishap on the sharp edge the edge trim must remain in place on the top edge of the gable until right and left roof panels are in place.

### PRUDENCE:

Pour éviter les accidents sur l'arête coupante de la garniture de bord, cette garniture doit rester en place sur le bord supérieur du pignon jusqu'à ce que les panneaux de toit droit et gauche soient en place.

### ADVERTENCIA:

Para evitar un accidente en el borde filoso, el recuadro del borde debe quedar en su lugar en el borde superior del frontón hasta que los paneles izquierdo y derecho están colocados.

### VORSICHT:

Um Unfälle zu vermeiden, sollte die scharfe Kante der Randleiste auf der oberen Kante des Giebels verbleiben, bis die rechten und linken Dachpaneelen angebracht sind.

# 8: GABLES

PIGNON  
GABLETE GIEBEL

261R

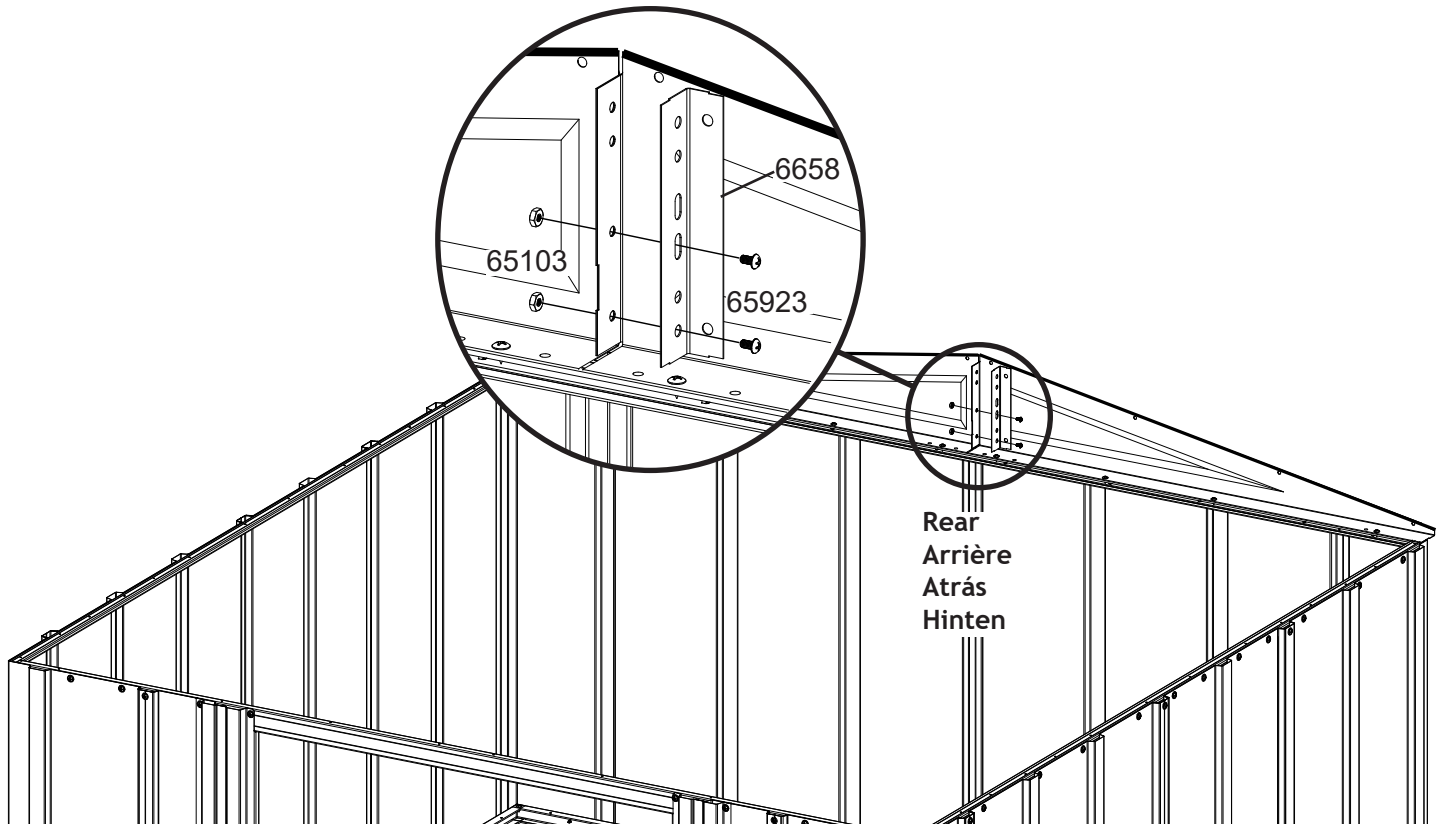
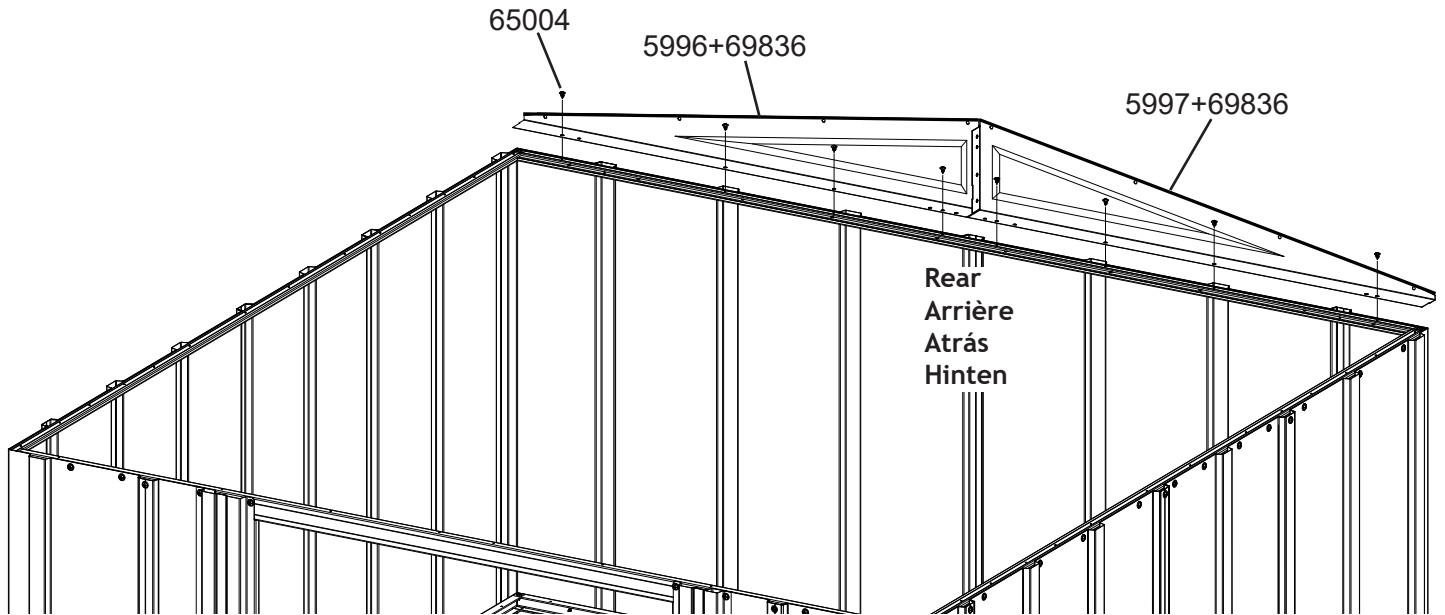
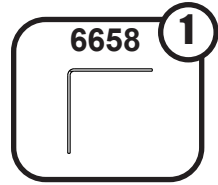
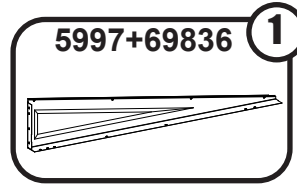
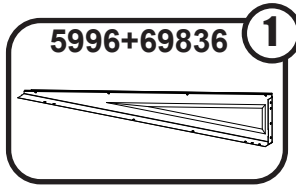
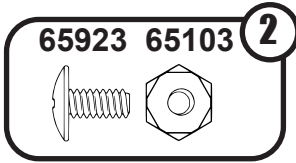
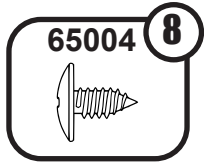

# 8: GABLES

PIGNON  
GABLETE GIEBEL

271R

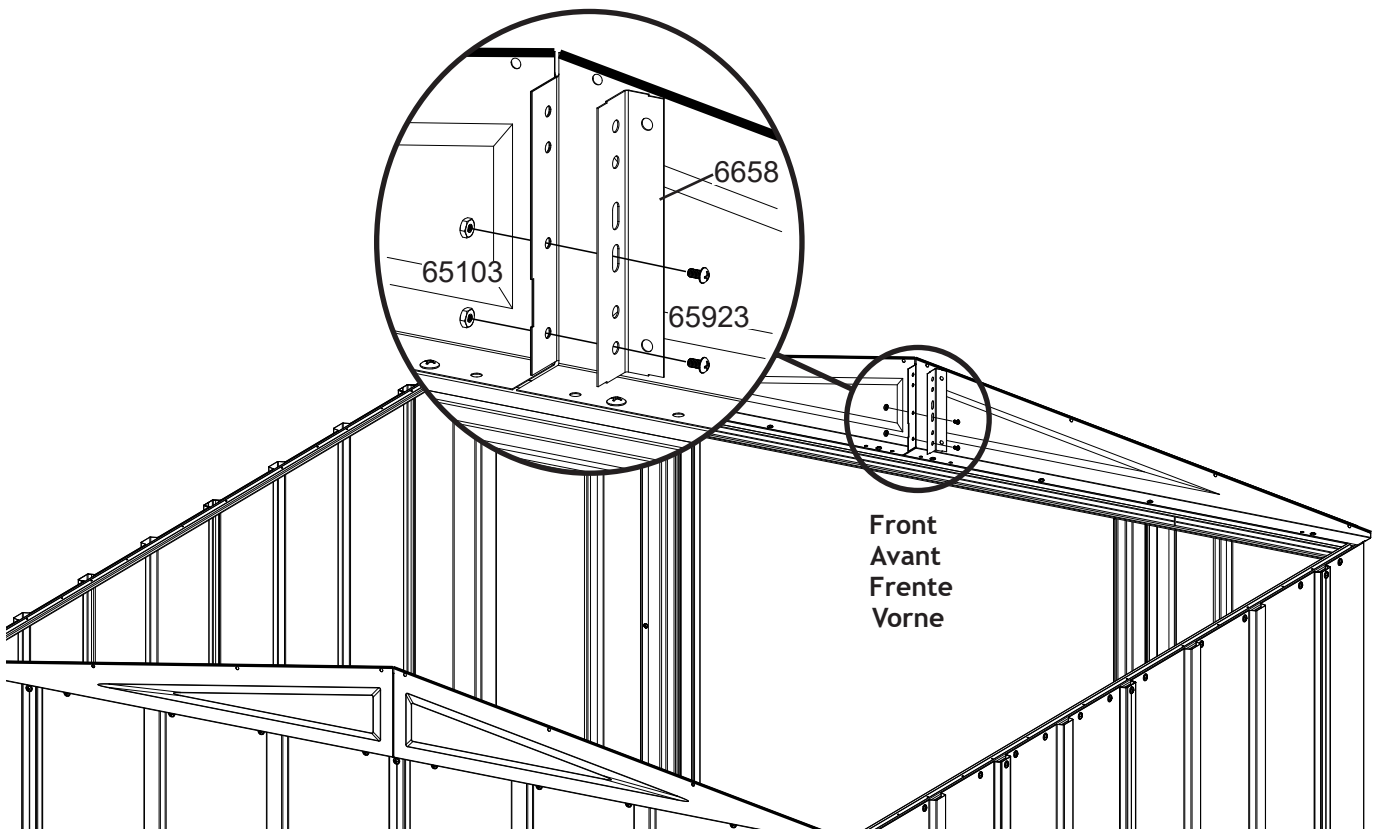
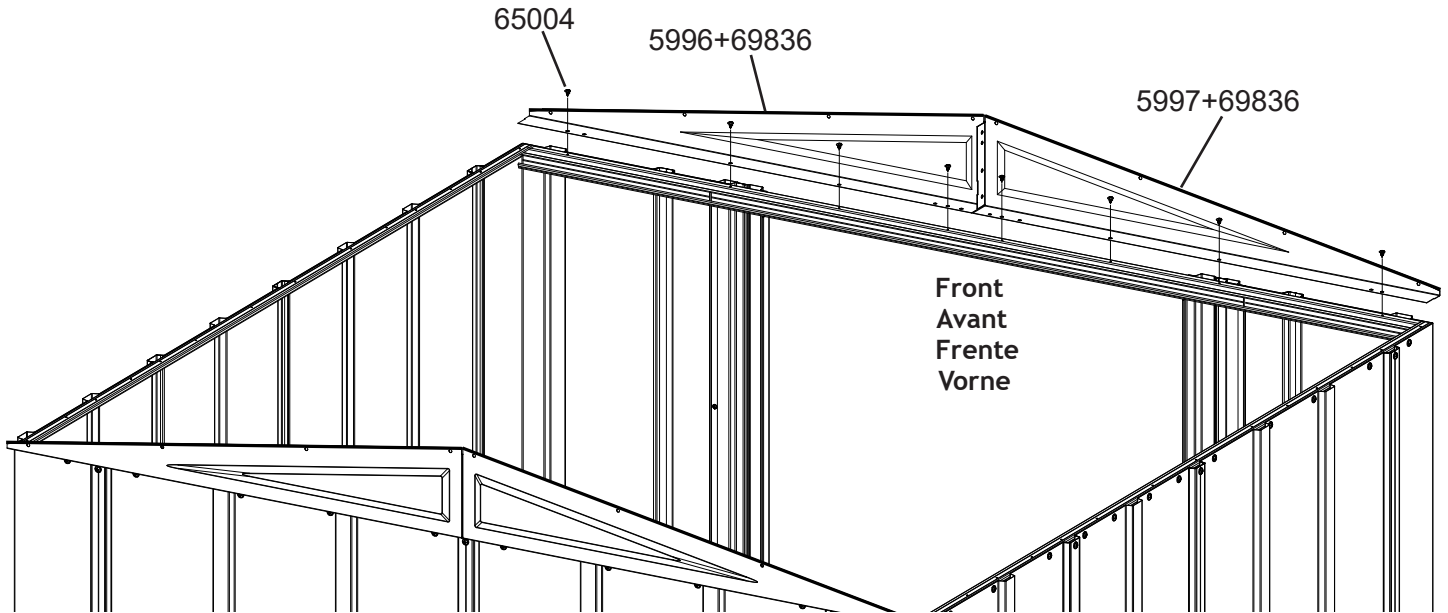
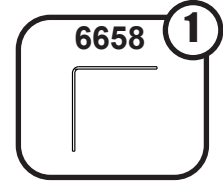
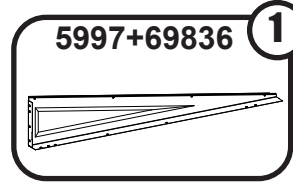
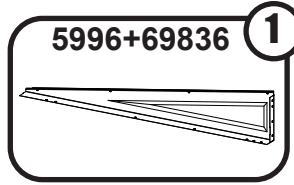
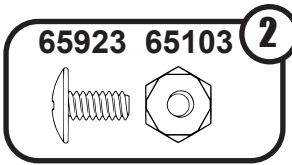
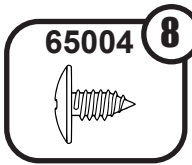

# 9: ROOF BEAMS

POUTRE DE TOIT  
VIGA DEL TECHO DACHTRÄGER

28IR

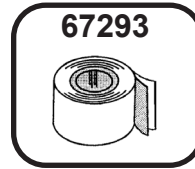
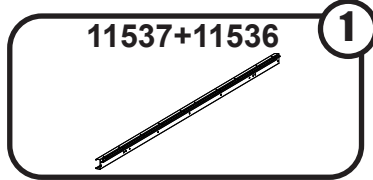
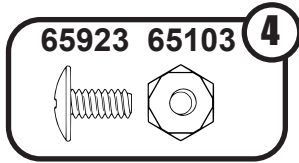

Top View of Gables  
Vue de dessus du pignon  
Vista superior de gabletes  
Draufsicht auf die Giebel

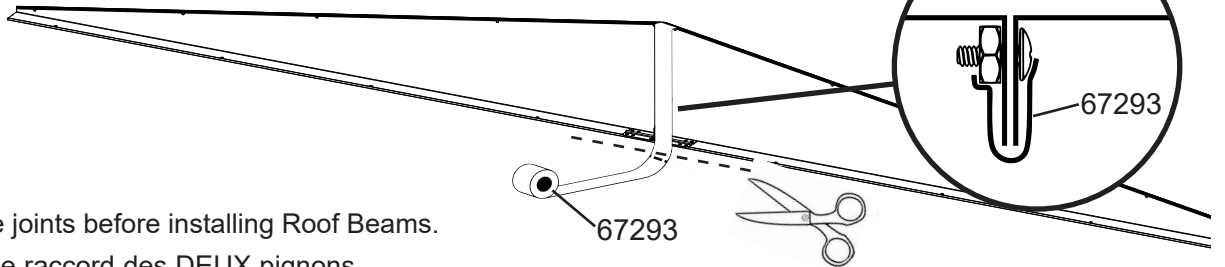

Tape BOTH Gable joints before installing Roof Beams.

Couvrir de ruban le raccord des DEUX pignons avant de poser les poutres du toit.

Coloque cinta adhesiva en AMBAS juntas del gablete antes de instalar las vigas del techo.

Kleben Sie BEIDE Giebelverbindungen zusammen, bevor Sie die Dachbalken montieren.

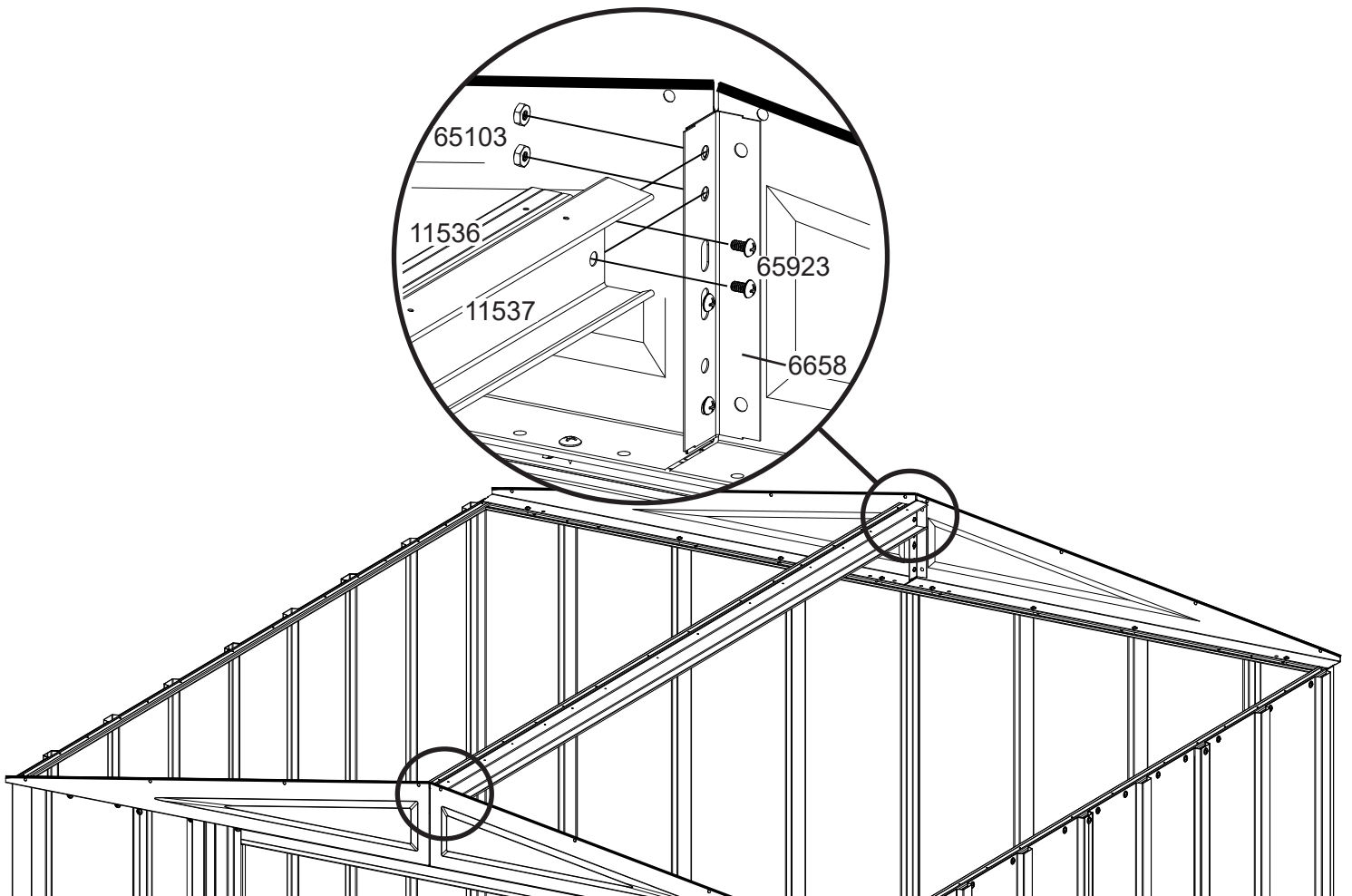

# 10: ROOF PANELS

PANNEAU DE TOIT  
 PANEL DEL TECHO DACHBLECH

29IR

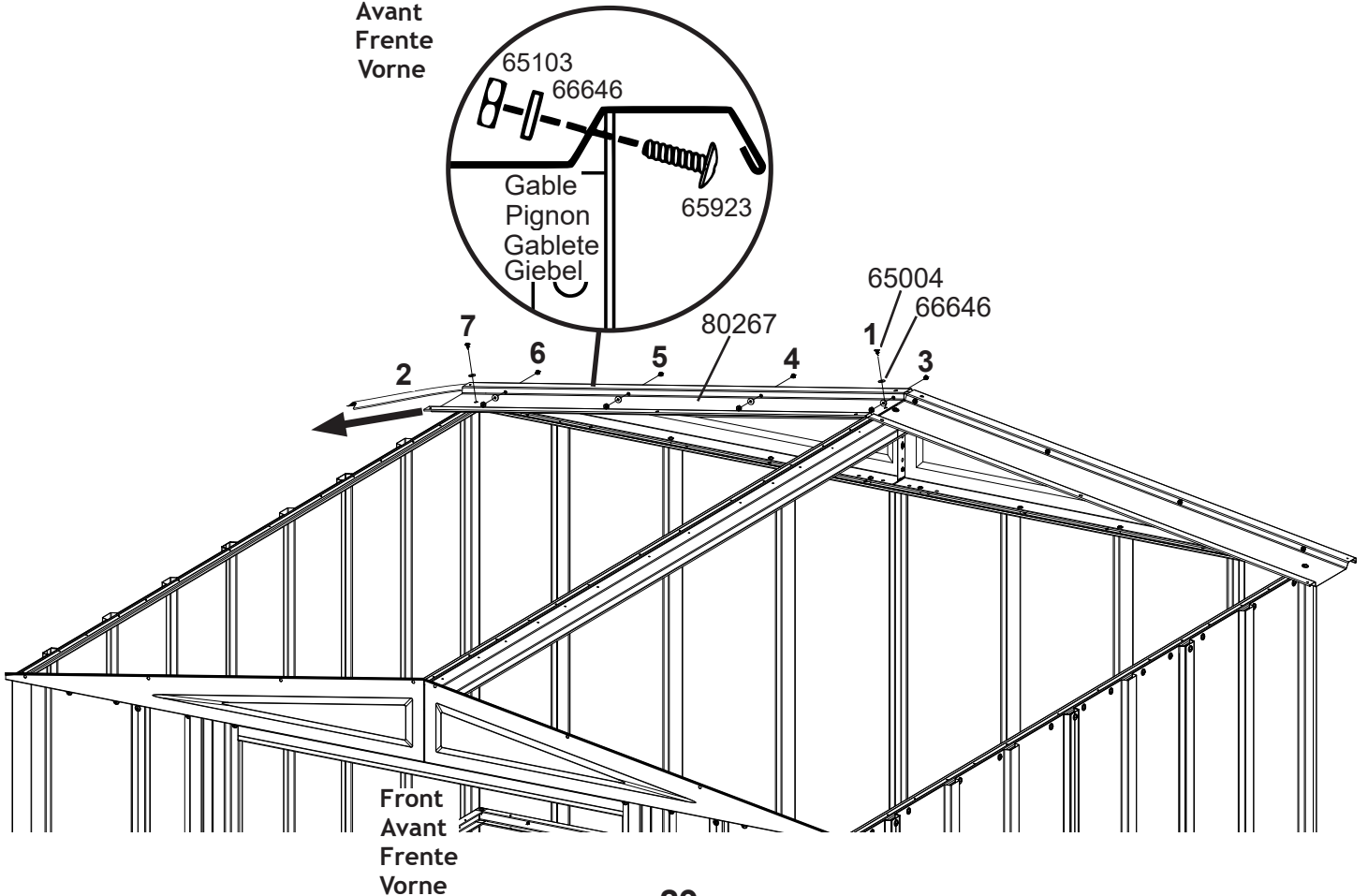
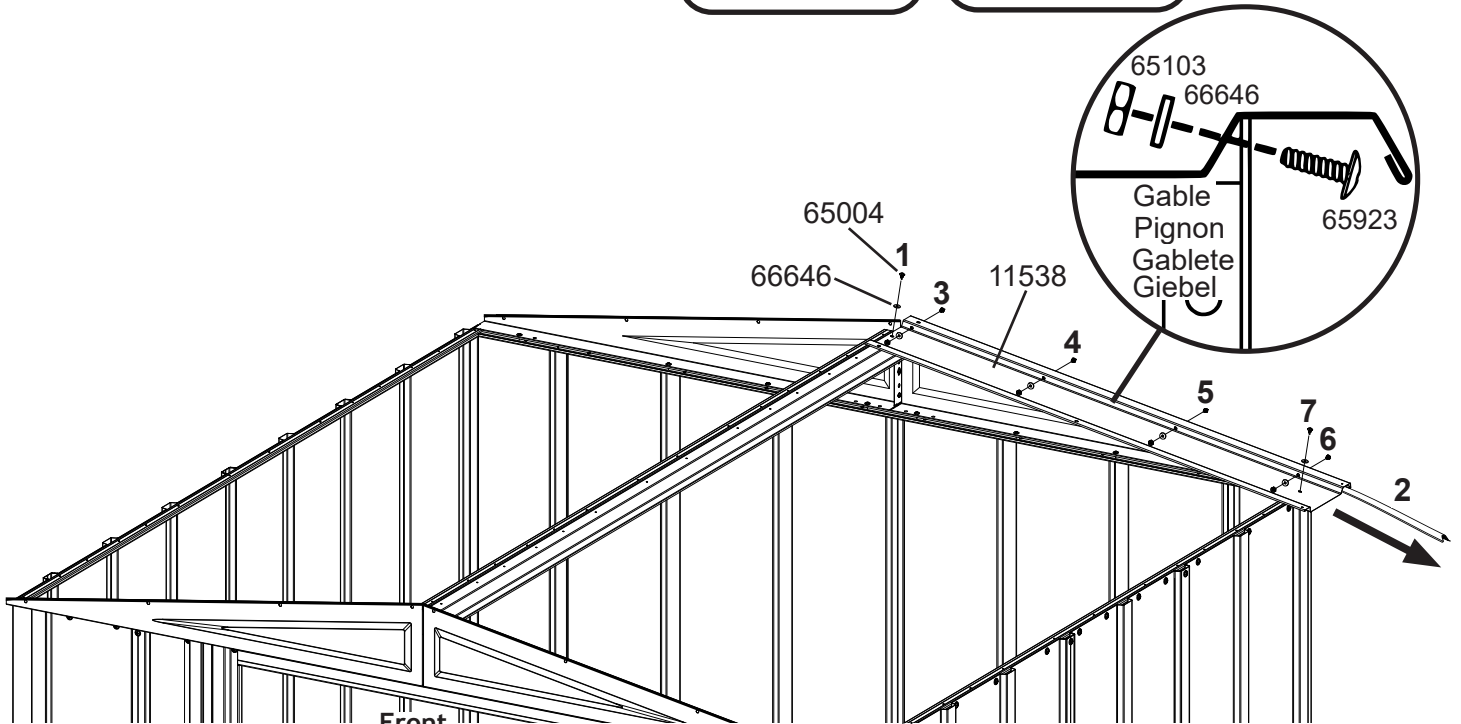
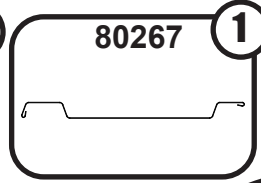
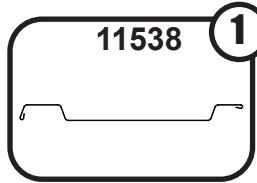
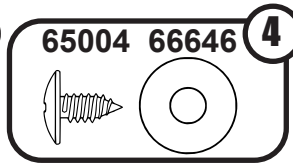
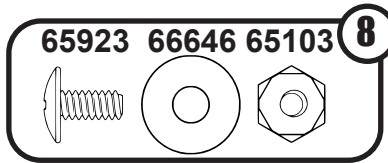

# 10: ROOF PANELS

PANNEAU DE TOIT  
 PANEL DEL TECHO DACHBLECH

30IR

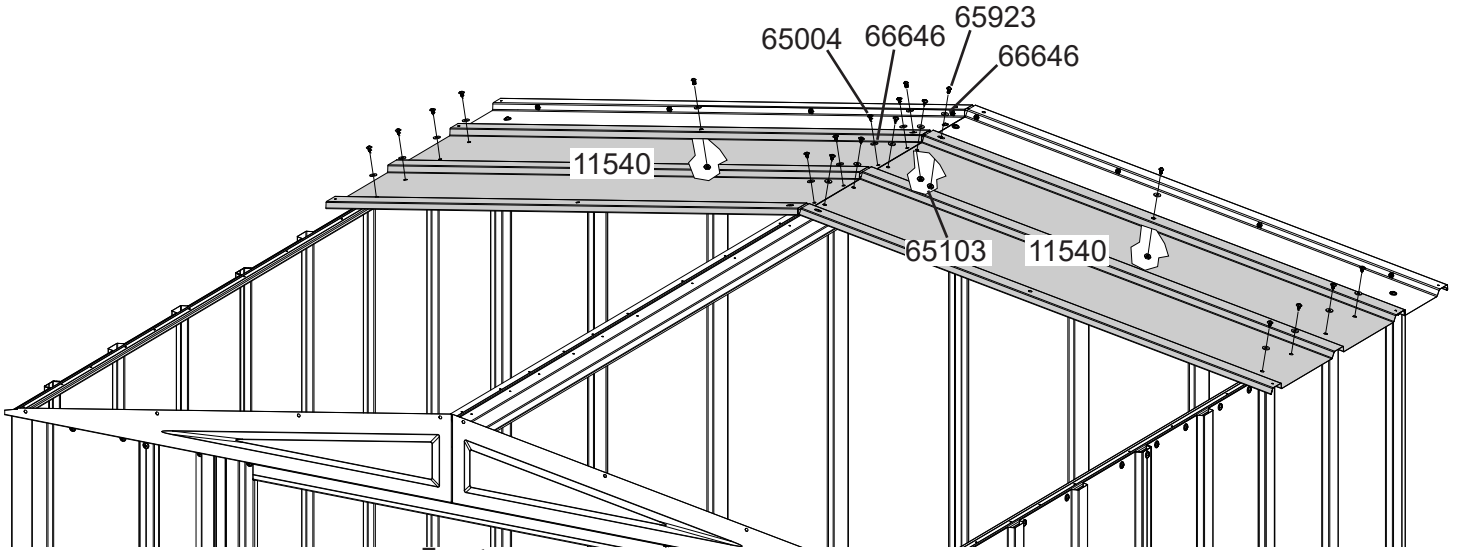
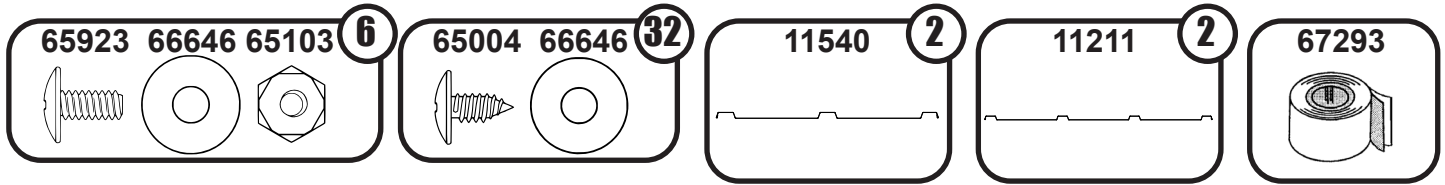

Front  
 Avant  
 Frente  
 Vorne

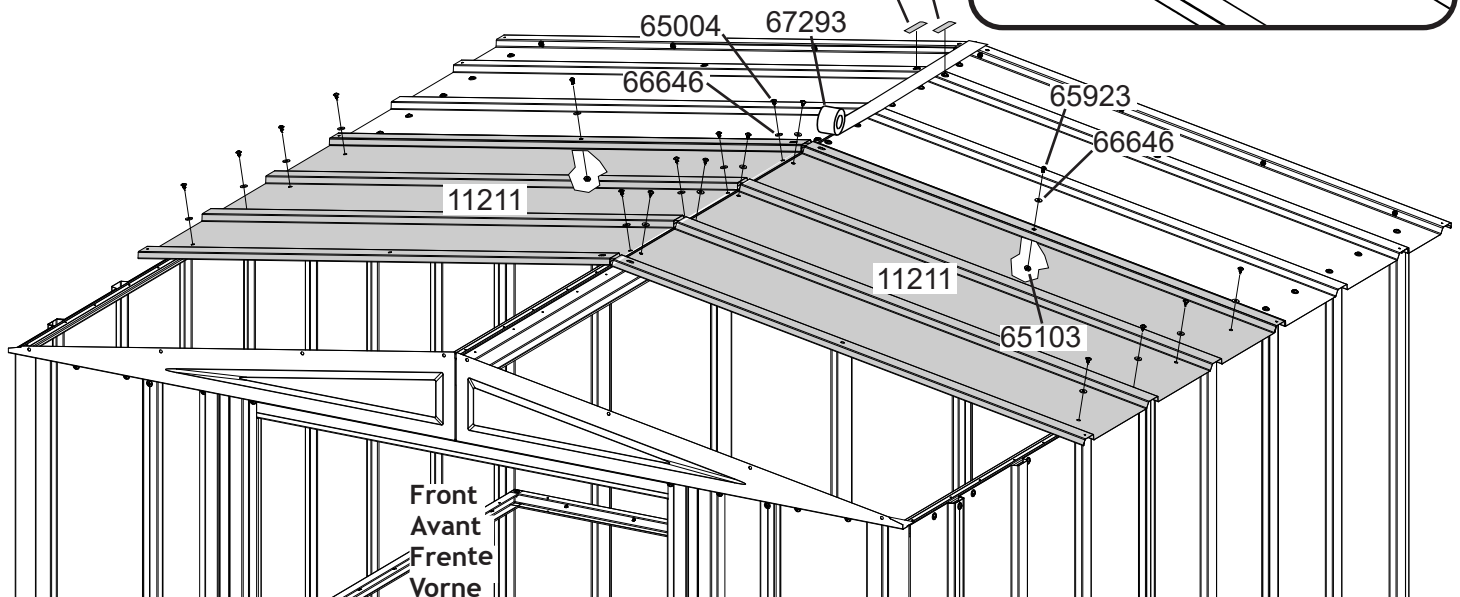
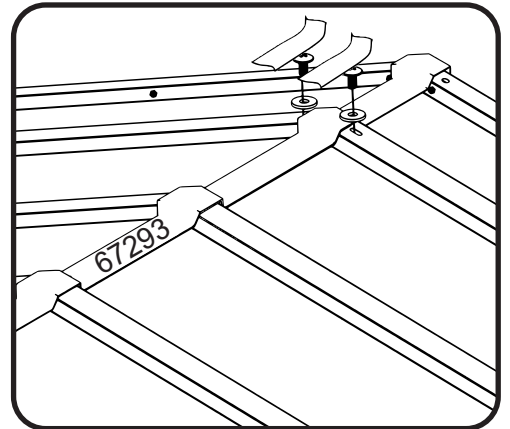
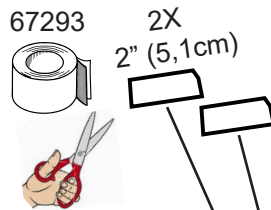

Front  
 Avant  
 Frente  
 Vorne

# 10: ROOF PANELS

PANNEAU DE TOIT  
 PANEL DEL TECHO DACHBLECH

31IR

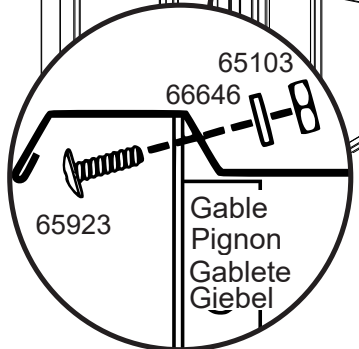
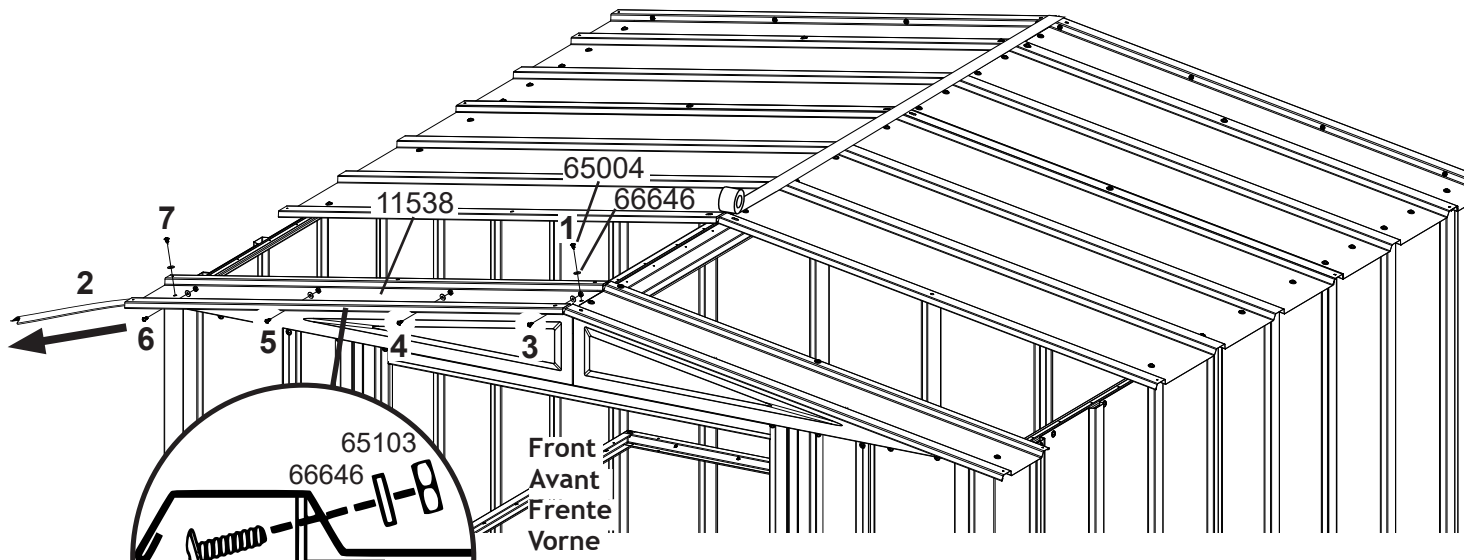
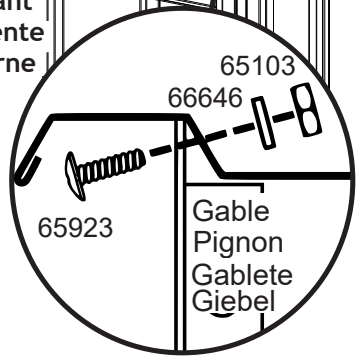
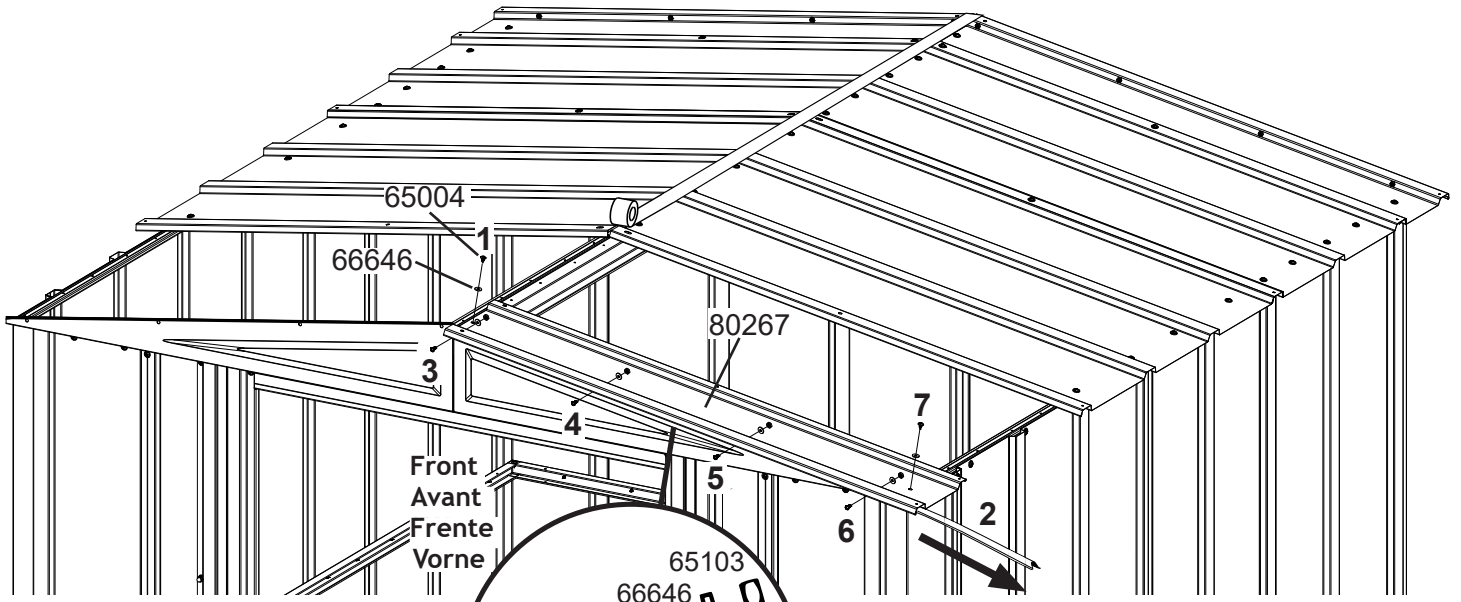
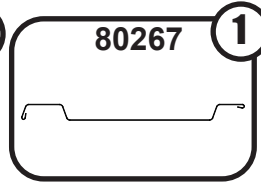
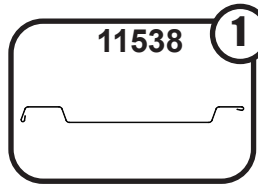
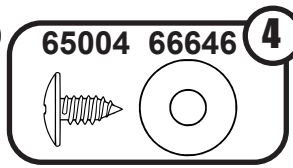
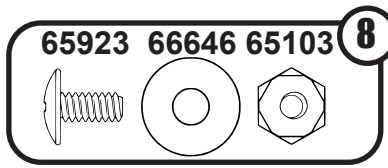

# 10: ROOF PANELS

PANNEAU DE TOIT  
PANEL DEL TECHO DACHBLECH

32IR

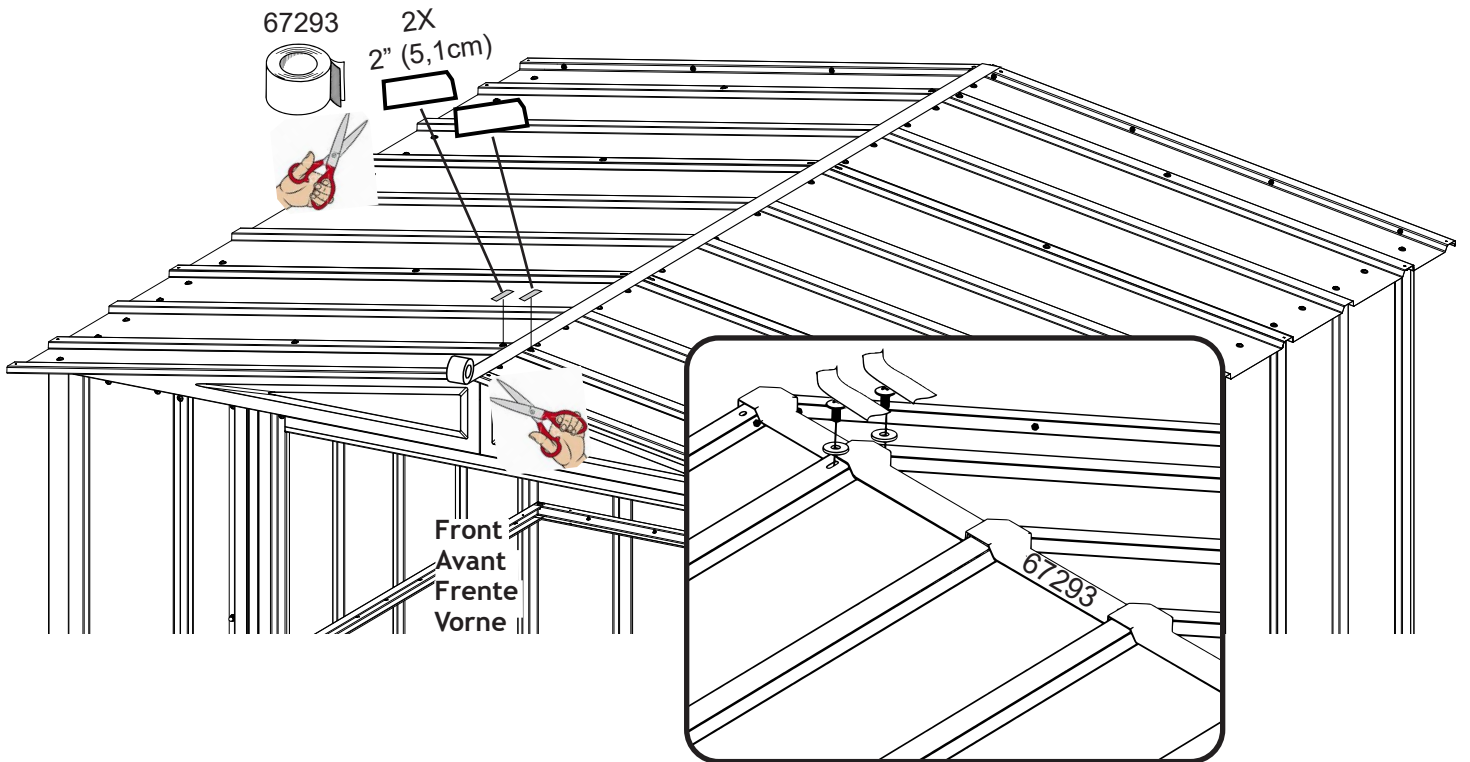
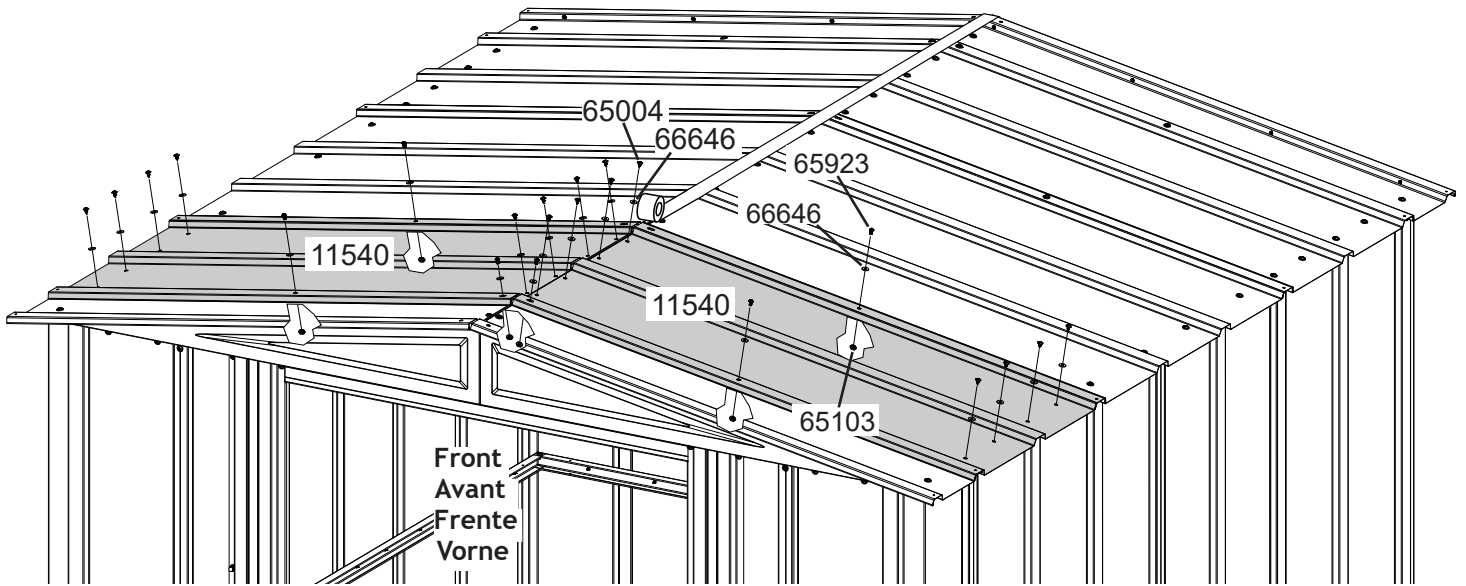
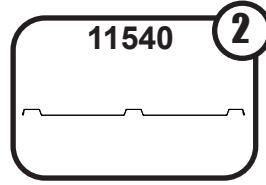
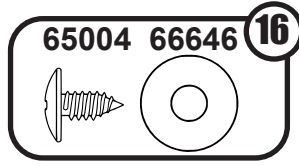
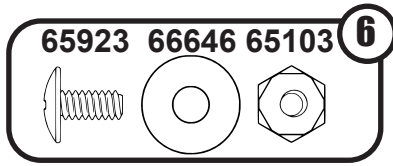



# 11: ROOF TRIM

GARNITURE DE TOIT  
CONTRAMARCO DEL TECHO DACHABSCHLUSSLEISTE

33IR

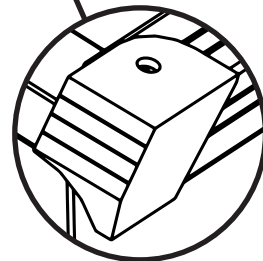
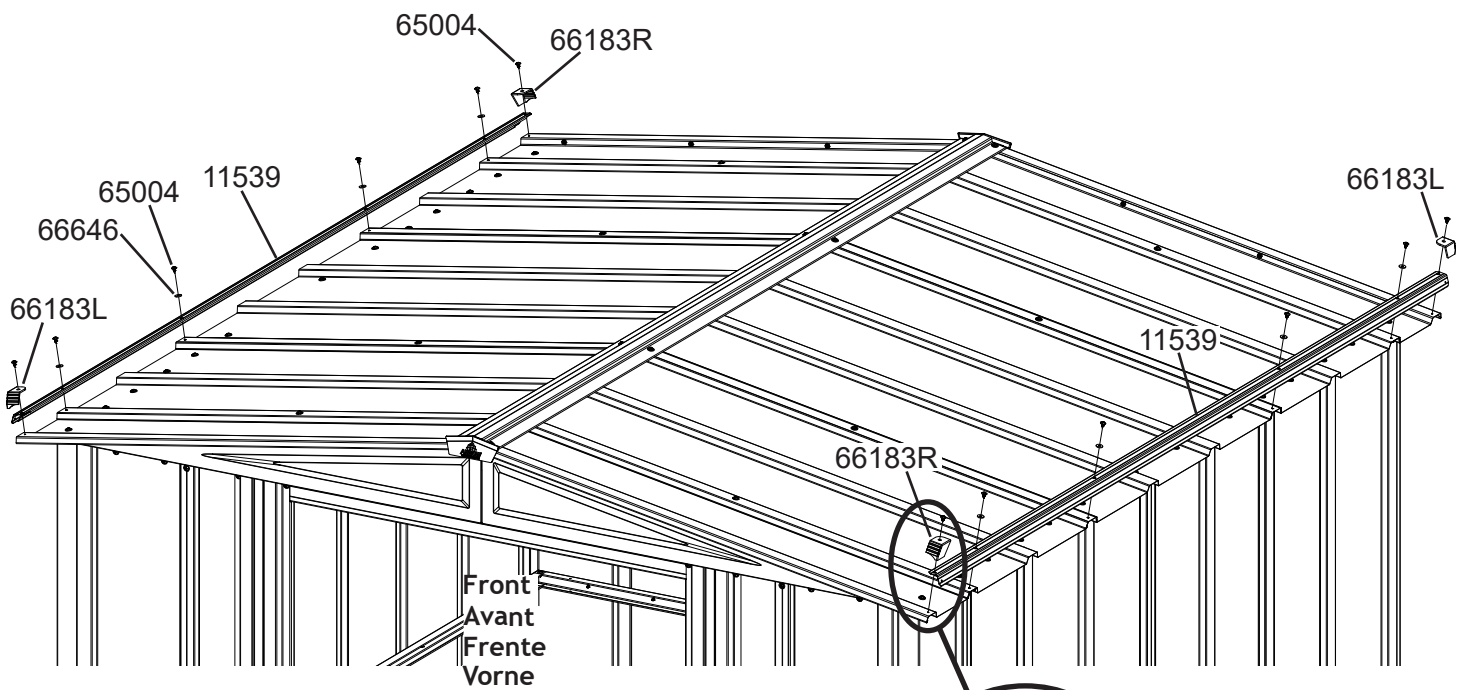
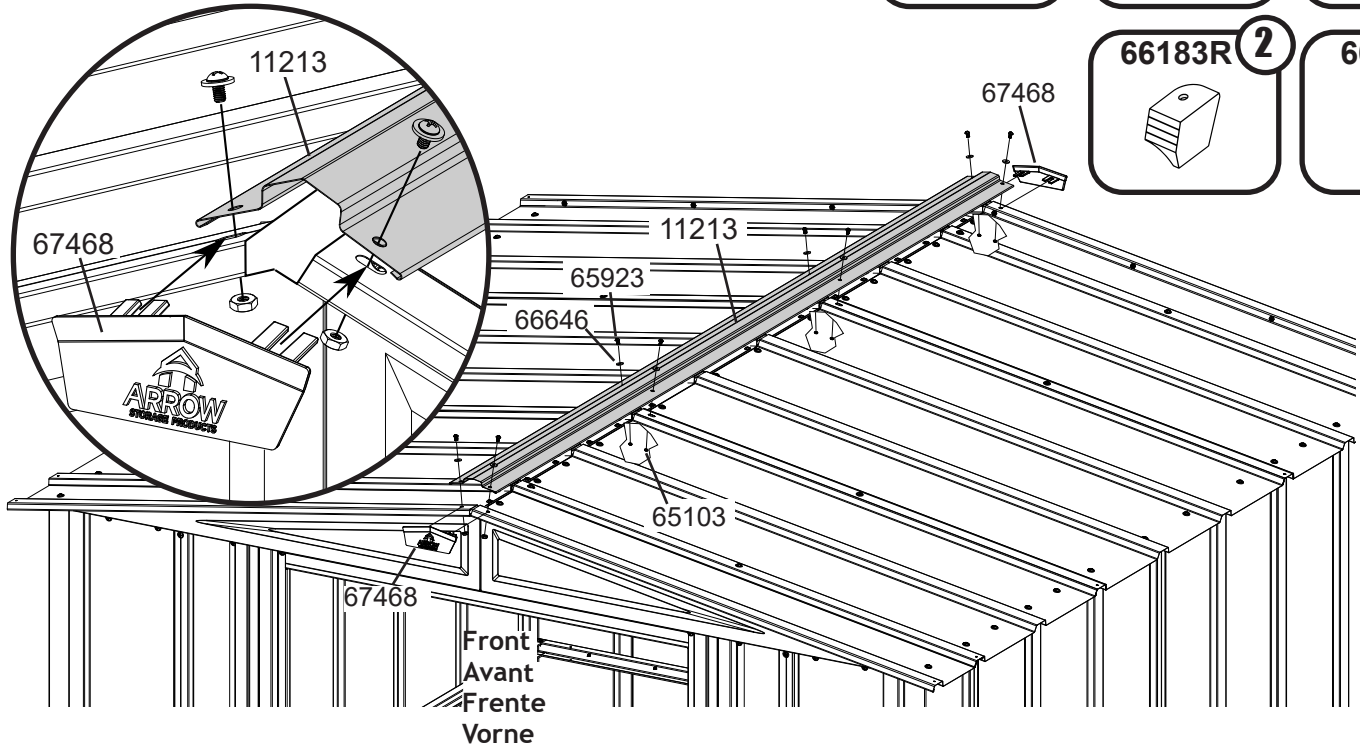
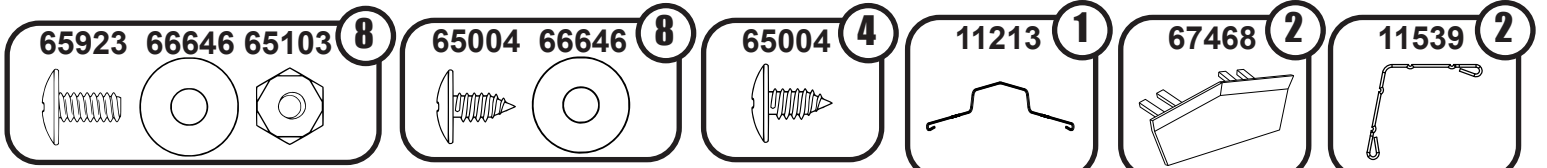

# 12: DOOR ASSEMBLY *PORTE ASSEMBLÉE* *ENSAMBLAJE DE LA PUERTA MONTAGE DER TÜRE*

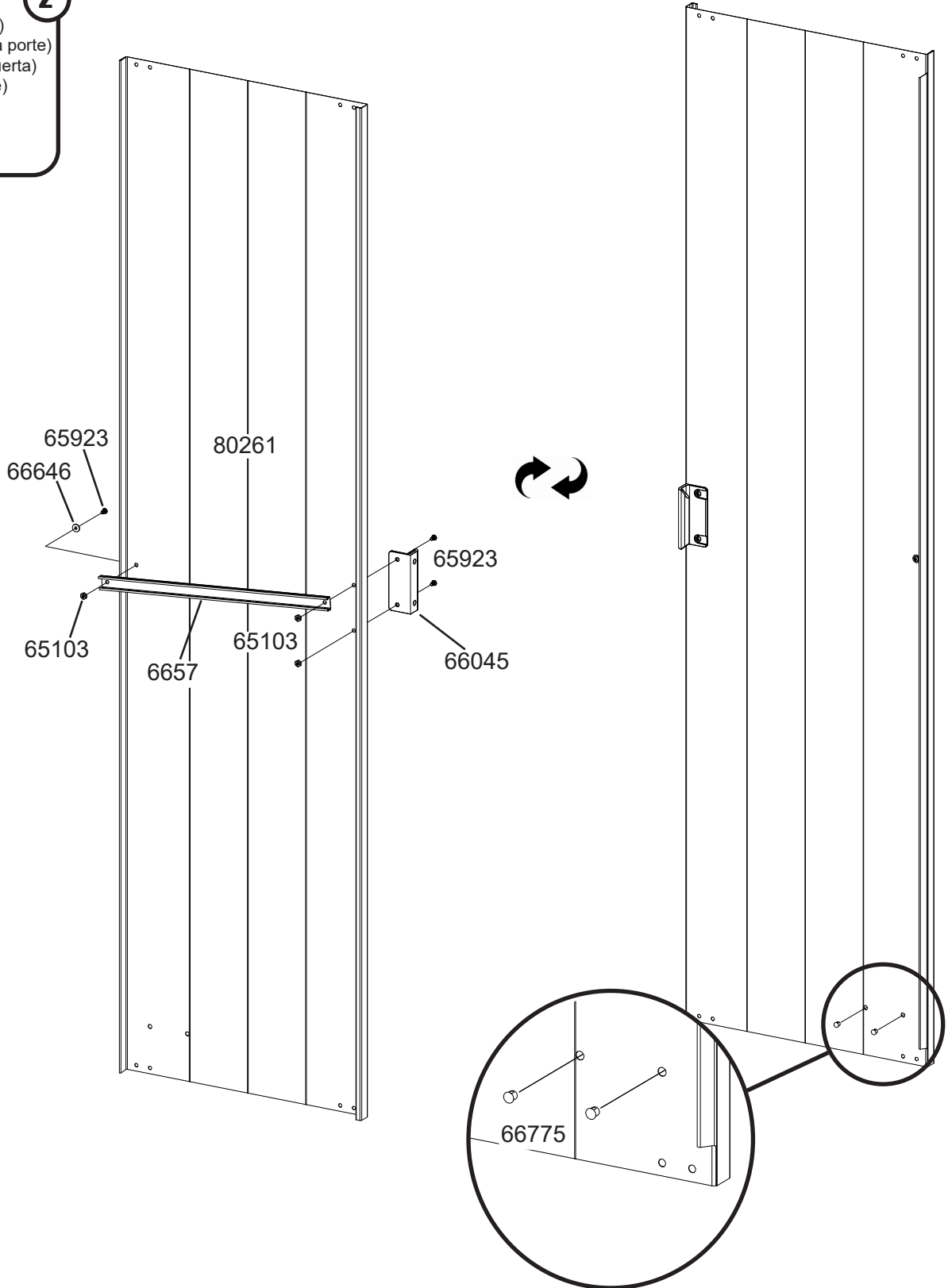
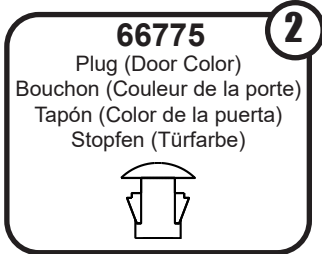
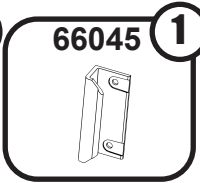
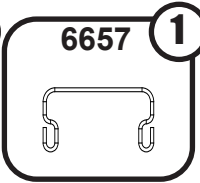
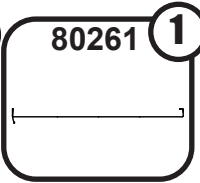
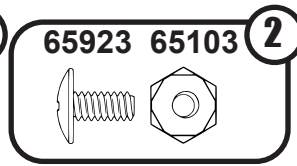
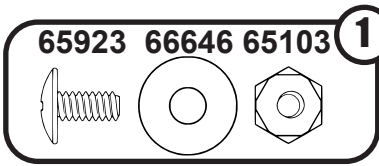

# 12: DOOR ASSEMBLY *PORTE ASSEMBLÉE* *ENSAMBLAJE DE LA PUERTA MONTAGE DER TÜR*

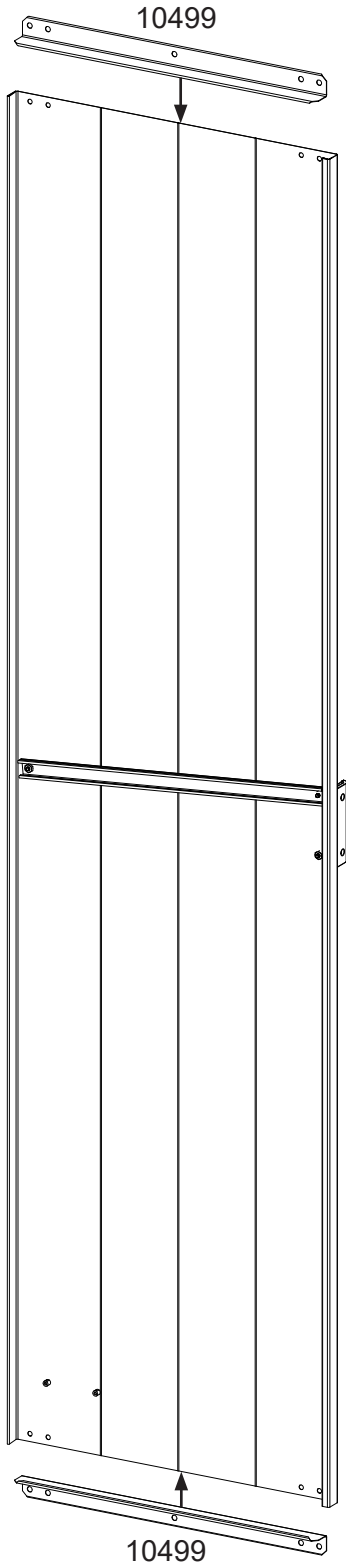
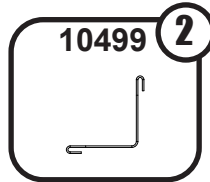
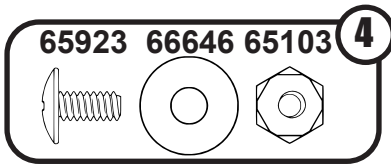

## Right Door Assembly *Ensemble de porte droite* *Ensamblaje de la puerta derecha* *Montage der rechten Tür*

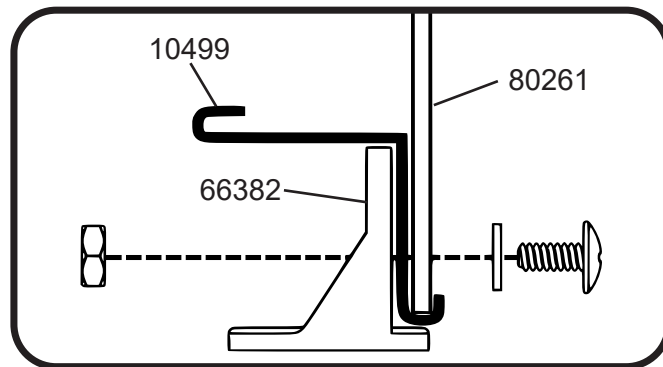
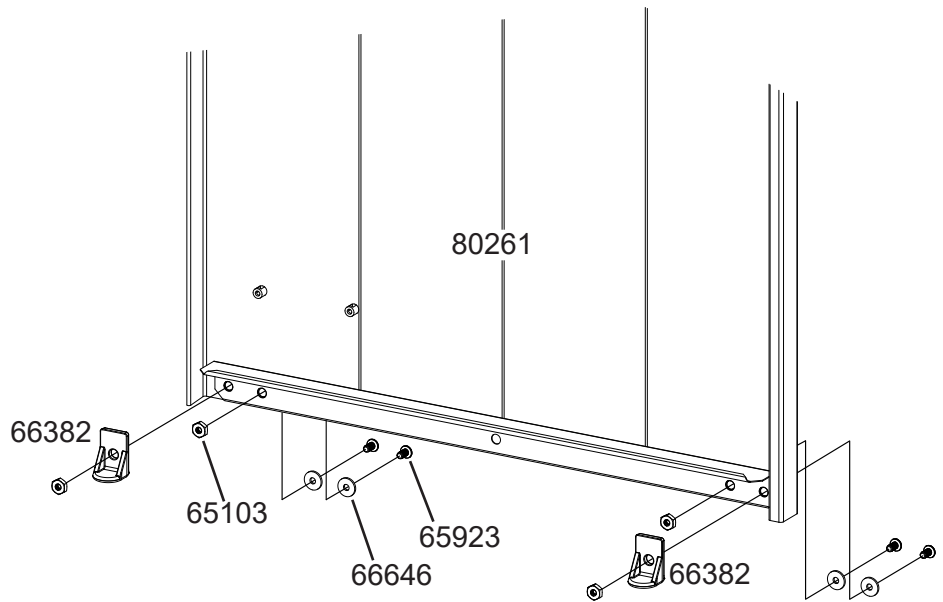

# 12: DOOR ASSEMBLY *PORTE ASSEMBLÉE* *ENSAMBLAJE DE LA PUERTA MONTAGE DER TÜRE*

36IJ

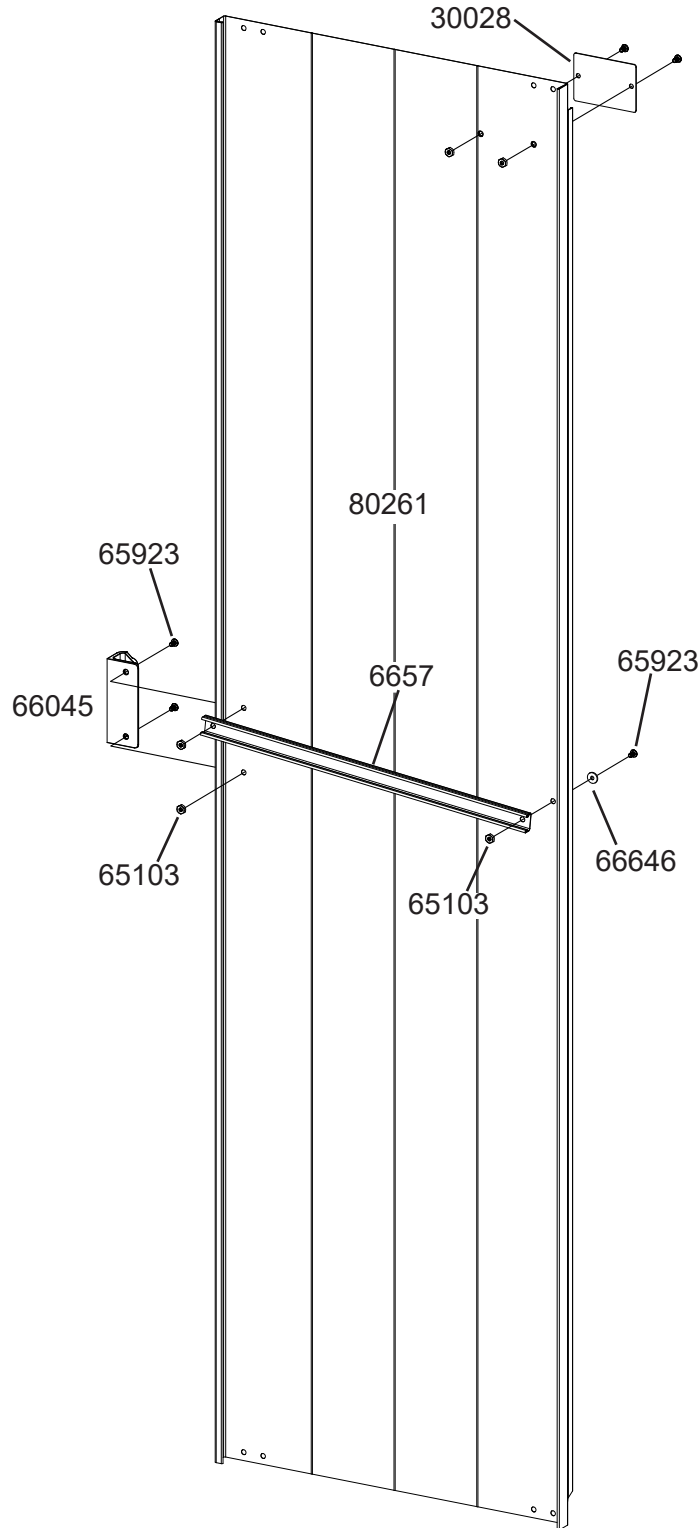
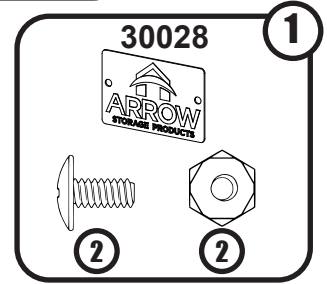
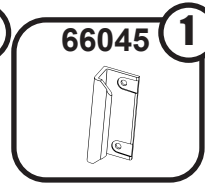
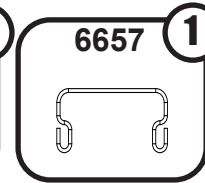
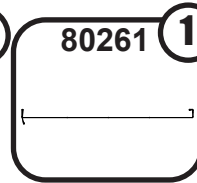
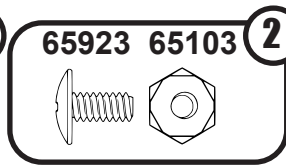
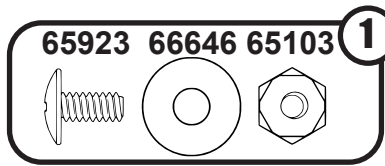

# 12: DOOR ASSEMBLY *PORTE ASSEMBLÉE* *ENSAMBLAJE DE LA PUERTA MONTAGE DER TÜR*

37IJ

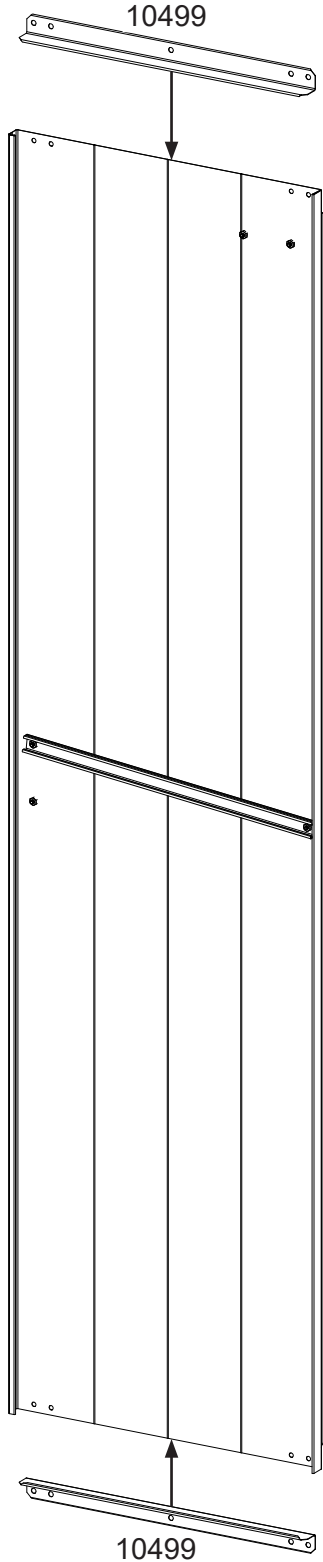
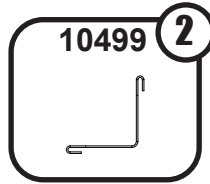
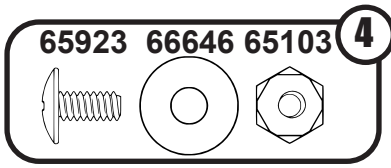

**Left Door Assembly**  
**Ensemble de porte gauche**  
**Ensamblaje de la puerta izquierdo**  
**Montage der linken Tür**

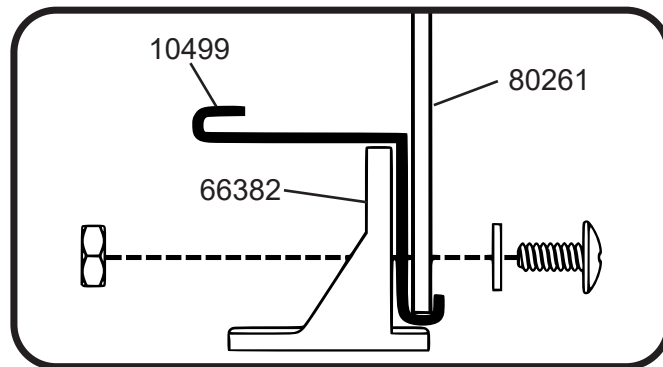
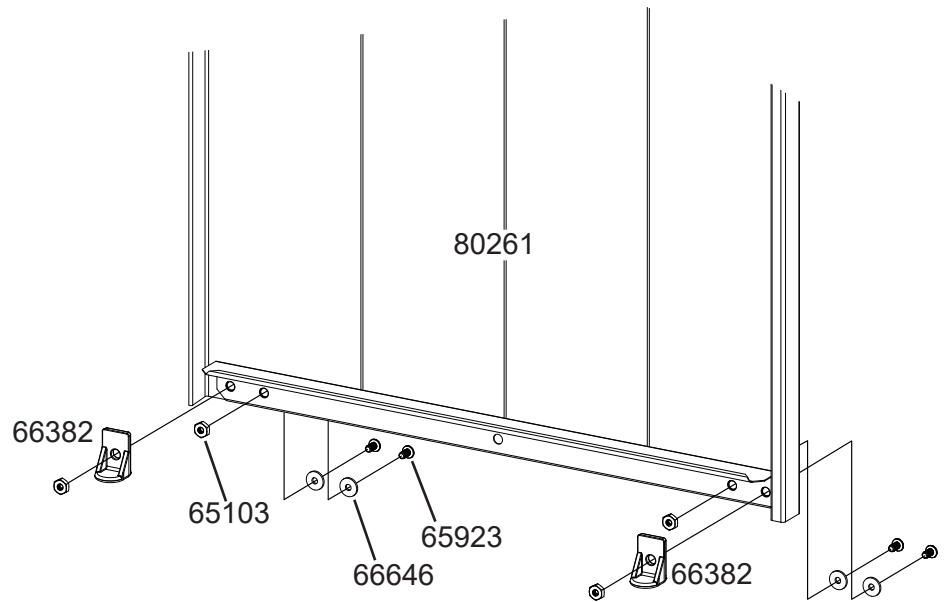

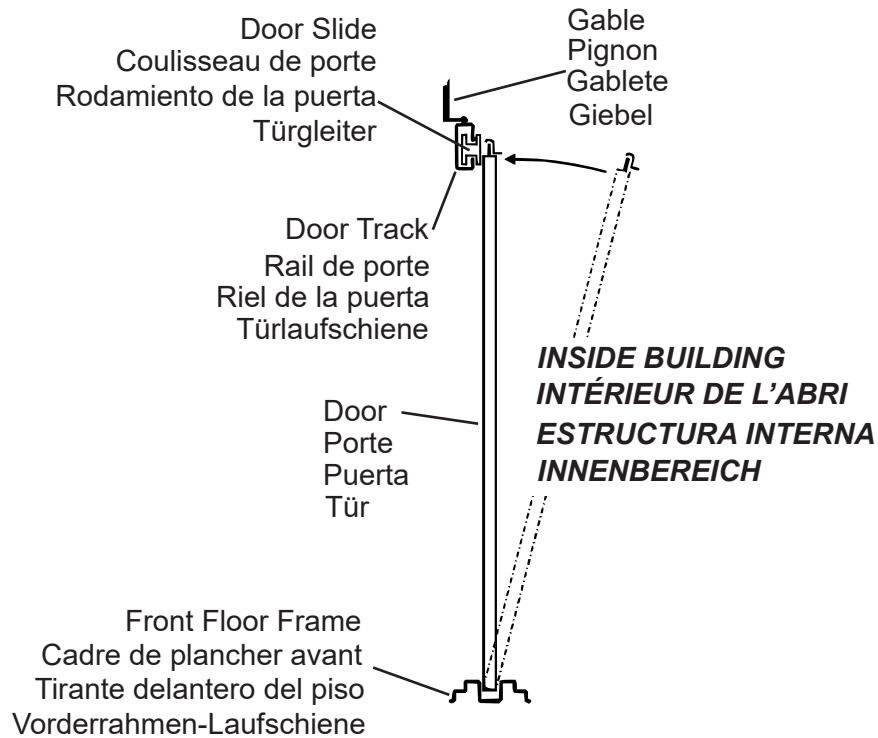
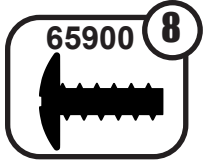

## **Door Adjustment** **Réglage de la porte** **Ajuste de la puerta** **Ausrichtung der Türe**

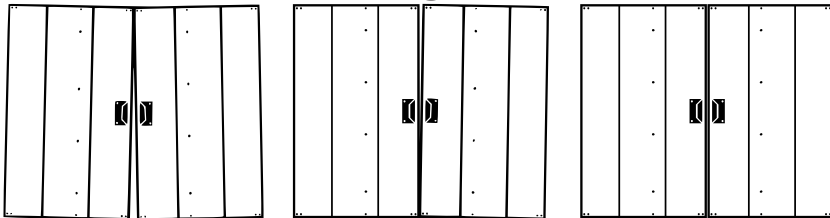
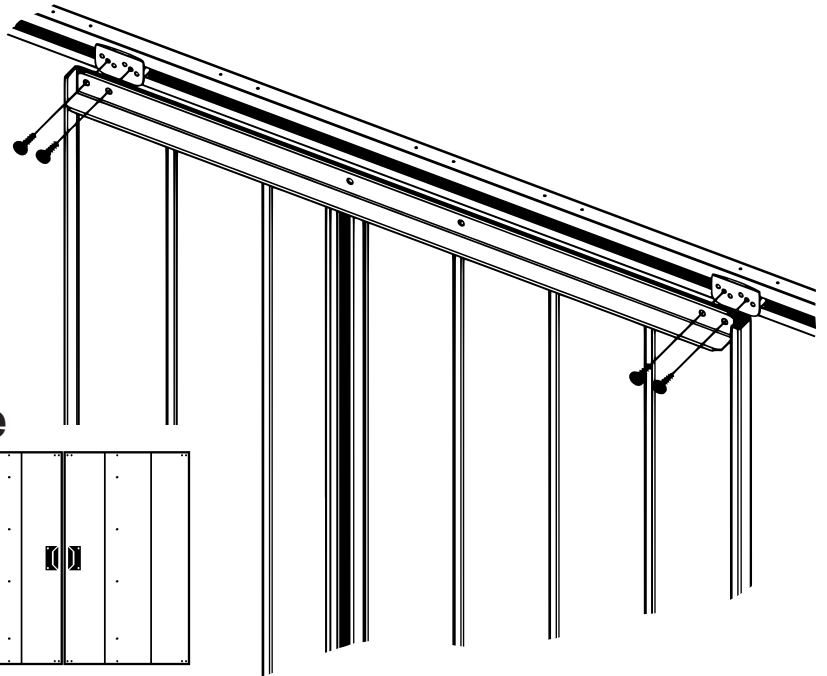

If Doors do not align, raise or lower one side of the Door by placing the Door screws through a different set of holes in the Door Slide.

Si les portes ne sont pas alignées, relever ou abaisser l'un des côtés de la porte en plaçant les vis de porte à travers un jeu de trous différents dans le coulisseau.

Si las puertas no se alinean, eleve o baje un lado e la puerta colocando los tornillos de la puerta por un grupo diferente de orificios en el rodamiento de la puerta.

Falls die Türen nicht richtig ausgerichtet sind, können Sie eine Seite der Tür anheben oder absenken, indem Sie die Türschrauben in den anderen Bohrungen des Türschlittens anbringen.

## **\* IMPORTANT \***

- *If you have swing doors, they must hang and swing level before anchoring building.*
- *Anchor your building at this time. Use appropriate 1/4"(6mm) X 1 1/2"(38,1mm) length hardware.*
- *Please take a moment to ensure that the building is installed in accordance with these instructions and with all applicable regulations.*
- *The entire floor frame MUST be securely anchored once the building is erected.*

## **\* IMPORTANT \***

- *Si l'abri comporte des portes battantes, vérifier qu'elles sont accrochées de niveau et pivotent librement avant d'ancrer l'ouvrage.*
- *Ancrez votre bâtiment en ce moment. Utilisez une longueur appropriée de 1/4 po (6 mm) X 1 1/2 po (38,1 mm) Matériel.*
- *Veiller à bien s'assurer que l'abri est installé conformément aux présentes instructions et à toute la réglementation en vigueur.*
- *Le cadre de plancher entier doit IMPÉRATIVEMENT être solidement ancré une fois que l'abri est assemblé.*

## **\* IMPORTANTE \***

- *Si tiene puertas vaivén, estas deben colgar y moverse en forma pareja antes de sujetar el cobertizo.*
- *Ancle su edificio en este momento. Use una herramienta apropiada de 1/4 "(6 mm) X 1 1/2" (38,1 mm) de longitud.*
- *Dedique unos minutos a asegurarse de que la estructura está instalada de acuerdo con estas instrucciones y con las reglamentaciones vigentes.*
- *Se DEBE anclar todo el tirante del piso cuando la estructura está erguida.*

## **\*WICHTIG\***

- *Wenn Sie Schwingtüren haben, müssen diese sauber hängen und schwingen, bevor der Schuppen verankert wird.*
- *Verankern Sie Ihr Gebäude zu diesem Zeitpunkt. Verwenden Sie angemessene Teile der Länge 1/4"(6mm) X 1 1/2" (38,1mm).*
- *Bitte überprüfen Sie noch einmal, ob der Schuppen im Einklang mit dieser Anleitung und mit allen geltenden Vorschriften aufgestellt wurde.*
- *Nach Aufstellung des Geräteschuppens MUSS der gesamte Bodenrahmen sicher verankert werden.*

