



OWNER'S & INSTRUCTION MANUAL

Quick Touch Vault Drawer

MODEL:

Digital Drawer (QTVDVD)

Digital + Bio Drawer (QTVDVDB)



SURELOCK-SECURITY.COM



ATTENTION



IMPORTANT! READ CAREFULLY, RETAIN FOR FUTURE REFERENCE. MANUAL MUST BE READ BEFORE OPERATING!

NEVER keep backup keys in your safe!

Do not store this document in your safe.

Mount your safe in a secure location.

Store a record of your combination and keys in a safe and secure location away from children.

- Make a record of your serial number on the lock. This is important information for the manufacturer to make duplicate keys, if they're lost.

DO NOT store loaded guns in this unit.

ALWAYS check to make sure the latch is closed. The lid requires a firm press on the top to lock automatically.



DISCLAIMERS



Neither seller nor manufacturer shall be liable for unauthorized access, any injury, loss or damage to personal property direct or consequential, arising out of the use of, or the inability to use the safe.

The user shall determine the suitability of the safe before the intended use and user assumes all risk and liability. Our safes are not intended to protect against environmental hazards including fire and water.

Be sure and follow all local and state firearm laws.

DO NOT operate a firearm without proper training and experience.

For any questions, issues, problems, concerns please contact us. Email: service@surelock-security.com

TABLE OF CONTENTS

Attention	2
Disclaimers	2
Parts & Specs	4
Introduction	5
Battery Installation	5
Battery Display	5
Opening Safe with the Backup Key	6
Programming	
Code Resetting	6
Registering Fingerprints	7
Deleting Fingerprints	8
Keypad Sound	8
Backlit Keypad	8
Installation	
Safe Installation	8
Mounting Instructions	9
Care and Maintenance	15
Troubleshooting	15
Lifetime Warranty	16
Safe Information	16

ENGLISH



COPYRIGHT NOTICE

Copyright 2021. All right reserved. No part of this manual may be copied, transmitted, transcribed, stored in a retrieval system, in any form or by any means without expressed written permission of.

DANSONS

3411 North 5th Avenue, Suite 500, Phoenix, AZ, USA 85013
service@surelock-security.com
www.surelock-security.com

CUSTOMER CARE

USA: (480) 923-9637

PARTS & SPECS

ENGLISH

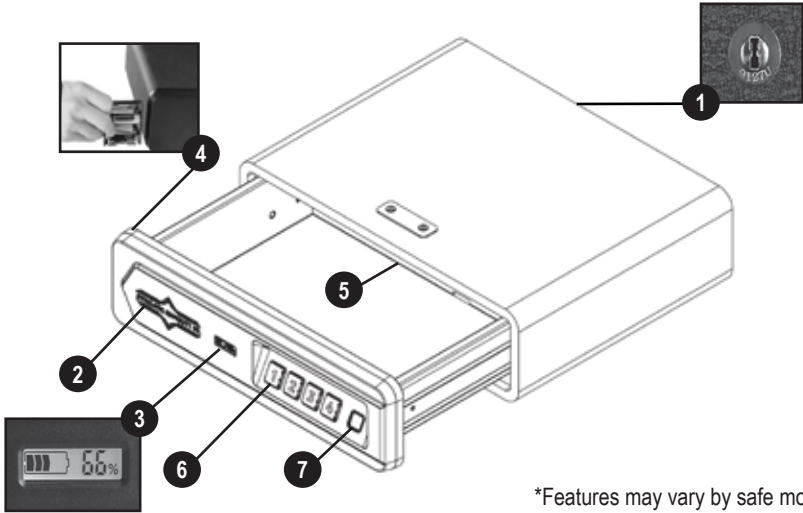

*Features may vary by safe model
(QTVDVDB shown)

- | | |
|---------------------------|-------------------------|
| 1. Keyhole and Key Number | 5. Program Button |
| 2. Brand Name Logo | 6. Keypad Keys |
| 3. Battery Display | 7. Fingerprint Scanner* |
| 4. Battery Compartment | |

MODEL	ASSEMBLED (WXDXH)	WEIGHT
QTVDVD/QTVDVDB	13.50x11.10x3.81 IN. 343x282x97 MM.	15.87 LBS / 7.20 KG

BOX CONTENTS

- | | | |
|---|---|--------------------------------|
| 1 | x | Safe & Attached Mounting Plate |
| 2 | x | Backup Keys |
| 6 | x | Mounting Screws |
| 1 | x | Manual |

**Batteries Not Included (use new 4 - AA Batteries)

INTRODUCTION

The Surelock Quicktouch Vault is a biometric fingerprint access, code access, and key access safe. It provides secure storage for valuables such as firearms, ammunition, cash, and other personal items. The safe combines high security with complete quick access control with its solid construction and biometric technology.

Please take time to read and familiarize yourself with the proper operating procedures presented on the following pages.

If you have any questions, problems, or need help configuring the system, please contact us at service@surelock-security.com.

ENGLISH

BATTERY INSTALLATION

1. Open the battery cover with a screwdriver.
2. Insert 4 - AA fresh alkaline batteries (not included) into the battery compartment.

Note: Pay attention to the "+" and "-" signs.

3. Install the battery compartment. Once the batteries are inserted correctly you will hear a short beep and see the keys light up once.

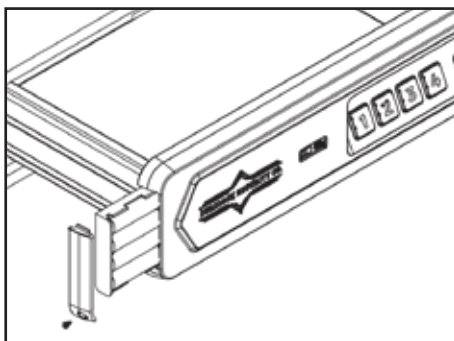

BATTERY DISPLAY



If battery display shows less than 20%, please replace the 4 new batteries. Use AA fresh alkaline batteries.

IMPORTANT: YOUR SAFE WILL AUTOMATICALLY LOCK WHEN YOU FULLY PUSH THE DRAWER. USE NEW AA ALKALINE BATTERY ONLY.

OPENING SAFE WITH THE BACKUP KEY

Locate the key hole at the back of the safe.
Turn the key counter-clockwise to open the safe.

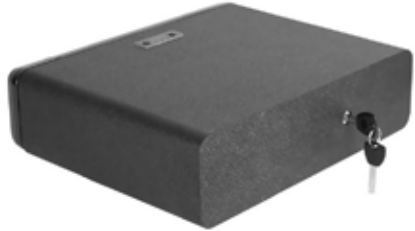

CODE RESETTING

Default Code: 1234

1. With the vault open, press and hold down the 'PROGRAM' button for 5 seconds and immediately remove your finger once you hear a beep and all keypad keys light up once.
2. Enter your NEW code.
(Code must be 3 digits to 8 digits).
3. Press the 'PROGRAM' button once and release it. The keypad keys will light up twice with two beeps and now your new code is set.
4. Test the code. The door will open if the correct code is entered. You will hear five beeps with lights flash if the wrong code. Repeat above steps if the new code doesn't work.



IMPORTANT

1. If 5 incorrect entries are made, the safe will go into alarm mode for 5 minutes with lights flashing and beeping. You can open the safe with the backup key and stop the alarm by removing the batteries.
2. Two Pin Code Buttons can not be pressed at the same time.
3. Programming a new code will overwrite your previous code.
4. If you forget the previous code, simply repeat the above steps to reset a new code.

NOTE: In Step 1, Remove your finger on the Program button immediately once you hear a beep. If you keep holding it down for about 10 seconds, you will hear two beeps and the Pin Code Buttons will light up twice. This will result with all registered fingerprints to be erased.

REGISTERING FINGERPRINTS

1. It is highly recommended that users should program a new vault code before registering fingerprints. To increase your success rate of registering a fingerprint, ensure that your hands are clean. Excessive moisture such as lotions or oils will affect your fingerprint and may cause inaccurate sensor readings. If you experience difficulty with a particular finger, try another.
2. When registering a fingerprint, adjust your finger slightly between scans for increased accuracy, shown in the illustration below.



To increase your success rate, register several fingerprints. Start by placing a single finger at the center of the scanner and change positions with each scan. This allows the scanner to read where most of the fingerprint detail is located.

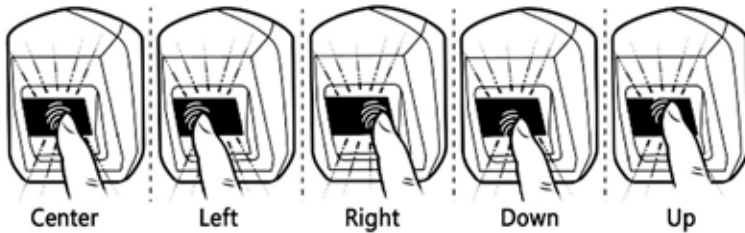

If you have any difficulties please contact our Customer Care team for help, advice, and how to videos.

1. With the vault open, press and hold the PROGRAM button for five seconds. All keypad keys (1-4) will light up once with one beep and the fingerprint scanner will light up BLUE.
2. Register ONE finger on the fingerprint scanner:
 - Place your finger on the center of the fingerprint scanner for the first scan. Wait for a short beep and the scanner will light up BLUE (1-2 seconds after placing finger). Lift your finger off.
 - Place the same finger again over the fingerprint scanner and repeat same process two more times. Adjust your finger slightly between scans for increased accuracy.
 - Once all keypad keys (1-4) light up twice with two short beeps, which confirms that the new fingerprint has been registered successfully.
3. Now test the fingerprint: close the door and place your finger on the fingerprint scanner. If you made a mistake and the fingerprint will not work, use the backup keys to open the vault and attempt to register again with a different finger.

IMPORTANT

- If all keys flash green 5 times with 5 beeps, it means registration has failed and you must repeat the above steps.
- The safe can hold 20 fingerprints. If the light flashes 5 times with 10 beeps when trying to register your fingerprint, it means the fingerprint storage capacity is full.
- To increase your success rate, please register the same finger multiple times in different positions.

Contact **Customer Care** if you encounter any problems

DELETING FINGERPRINTS

With the vault open, press and hold the PROGRAM button (for 8-10 seconds) until all the keypad keys (1-4) flash twice with double beeps, then release. All registered fingerprints are now erased.

IMPORTANT: WHEN THE KEYPAD KEYS FLASH ONLY ONCE WITH ONE BEEP, KEEP HOLDING. YOU MUST HOLD THE PROGRAM BUTTON UNTIL THE KEYS FLASH TWICE WITH DOUBLE BEEPS, THEN RELEASE.

KEYPAD SOUND

You can turn off the "BEEP" sound of the keypad by pressing and holding the 1 button for 3 seconds to turn on/off the sound.

BACKLIT KEYPAD

Placing your hand next to the keypad or the keyboard will light up.

SAFE INSTALLATION

CHOOSING A LOCATION FOR YOUR SAFE:

The location of your safe is very important. For optimal safety and security, we recommend installing your safe in a location with a level surface. We also suggest a cool and isolated area, away from combustibles. Due to the fact that heat rises, avoid putting your safe in the upper level of your home. Avoid placement near a furnace or water heater or anywhere that flammable materials are present.

For added protection, we suggest storing the safe in a location that is convenient, but out of sight from others.

MOUNTING INSTRUCTIONS

ON A DESK WITHOUT A MOUNTING PLATE

1. Open your safe and press the small handles on the outside of the drawer sliders. Slide out the drawer to separate from the safe base.

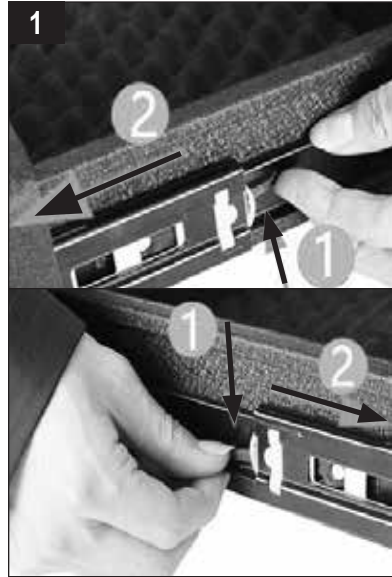

2. Unscrew the nuts that secure the plate to the bottom of the safe.

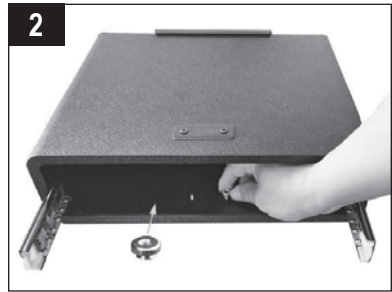

3. Flip the safe base and pull the plate away from the safe.



4. Pull out the slide bar from the safe base and reconnect the drawer.



5. Place the safe on top of the desk.



ON A DESK WITH A MOUNTING PLATE

1. Put the safe on the desk and mark the position of the plate.

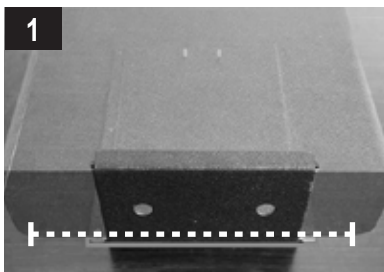

2. Open your safe and press the small handles on the outside of the drawer sliders. Slide out the drawer to separate from the safe base.

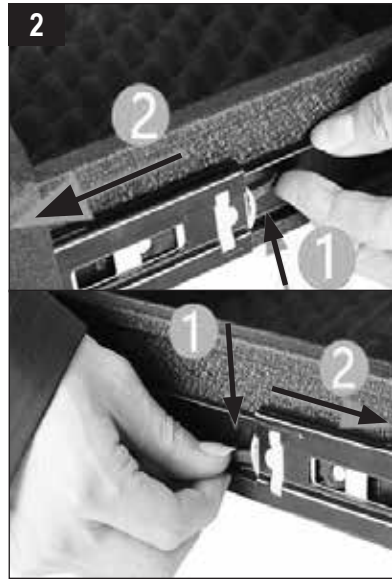

3. Unscrew the nuts that secure the plate to the bottom of the safe.

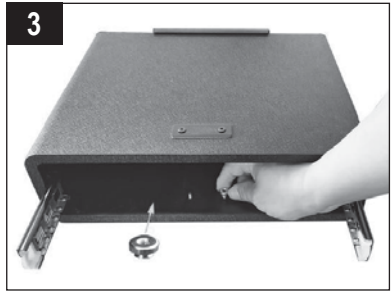

4. Flip the safe base and pull the plate away from the safe.

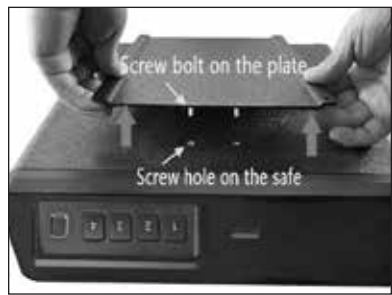

5. Attach the plate to the surface with six mounting screws that are provided.

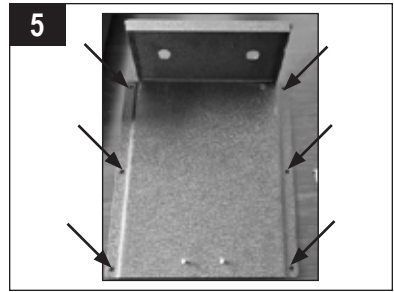

6. Place the safe on the attached plate.



7. Replace the nuts to the plate attached bolts.



8. Pull out the slide bar from the safe base and reconnect the drawer. Close the safe.



UNDER A DESK WITH THE MOUNTING PLATE

1. Open your safe and press the small handles on the outside of the drawer sliders. Slide out the drawer to separate from the safe base.



2. Remove the bolted plate on top of the safe with an Allen Wrench. *Wrench not included.

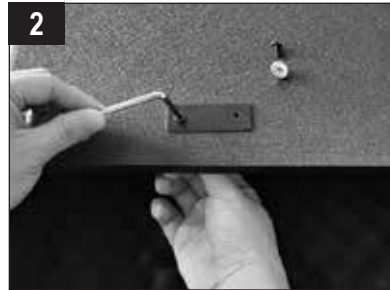

3. Flip the safe base and pull the plate away from the safe.



4. Mark the position of the plate.

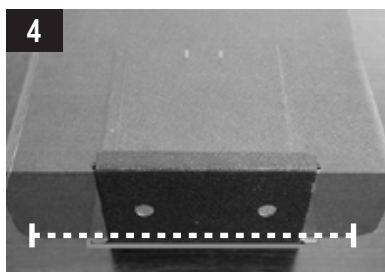

5. Attach the plate to the surface with six mounting screws that are provided.

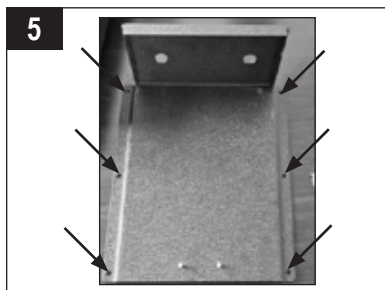

6. Place the safe on the attached plate



7. Replace the nuts to the plate attached bolts.

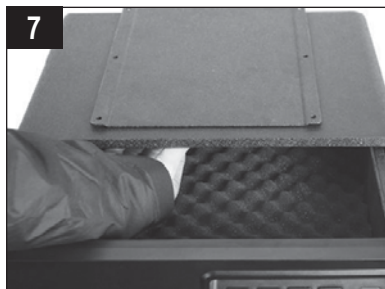

CARE AND MAINTENANCE

- Test your registered fingerprints every 6 months.
- Keep liquids away from the control panel.
- Place your safe in secure area.
- DO NOT disassemble the product. Contact Customer Care for all repairs.
- Use only NEW AA alkaline batteries.

Fingerprint Scanner

- Wipe the fingerprint scanner clean to maximize the security and performance of your safe. Use a dry cloth to remove any smudges or prints off of the fingerprint scanner after each use.

Component Part	Clean Frequency	Cleaning Method
Outside Metal	As needed	Damp cloth with soap and water. DO NOT use metal polishes, cleaners, or other chemicals.

TROUBLESHOOTING

What should I do if the batteries failed or I forget my code and the fingerprint doesn't work?

Use your backup key to open the safe. While the safe is open you can reset the code and fingerprints.

What should I do if I can not find the keys?

Contact Customer Care to make new keys for you.

How to stop the alarm status?

Use the backup key to open the door and reinstall the batteries or wait five minutes.

If you have any questions, issues, or problems; please contact Dansons Customer Care at (480) 923-9637 or Toll Free at 1-877-942-2246 and provide them with your safe's serial number. They will be able to assist you with regards to your combination.

LIFETIME WARRANTY

SureLock Security Company (“SureLock”, “SureLock Security”, or “SureLock Security Co.”) cabinets, vaults and safes, manufactured by Dansons, carry a limited warranty from the date of sale by the original owner. The warranty coverage begins on the original date of purchase and proof of date of purchase, or copy of original bill of sale, is required to validate the warranty. Customers will be subject to parts, shipping, and handling fees if unable to provide proof of the purchase or after the warranty has expired. This warranty extends to the initial consumer only and is non-transferable.

Dansons carries a three (3) year warranty against defects and workmanship on all parts. Dansons warrants that all part(s) are free of defects in material and workmanship, for the length of use and ownership of the original purchaser. Warranty does not cover damage from wear and tear, such as scratches, dents, dings, chips or minor cosmetic cracks. High temperatures, excessive humidity, water and salt are some of the substances that can affect metal coatings. For these reasons, the warranty does not cover rust or oxidization. This warranty will not apply nor will Dansons assume responsibility if your appliance has not been installed, operated, cleaned and maintained in strict accordance with this owner’s manual. The warranty does not cover damage or breakage due to misuse, improper handling or modifications.

Neither Dansons, or authorized SureLock dealer, accepts responsibility, legal or otherwise, for the incidental or consequential damage to the property or persons resulting from the use of this product. Whether a claim is made against Dansons based on the breach of this warranty or any other type of warranty expressed or implied by law, the manufacturer shall in no event be liable for any special, indirect, consequential or other damages of any nature whatsoever in excess of the original purchase of this product. All warranties by manufacturer are set forth herein and no claim shall be made against manufacturer on any warranty or representation.

Some states do not allow the exclusion or limitation of incidental or consequential damages, or limitations of implied warranties, so the limitations or exclusions set forth in this limited warranty may not apply to you. This limited warranty gives you specific legal rights and you may have other rights, which vary from state to state.

USA: (480) 923-9637
service@surelock-security.com | www.surelock-security.com

SAFE INFORMATION

MODEL: _____

SAFE SERIAL NUMBER: _____

SAFE COMBINATION NUMBER: _____

PURCHASED FROM: _____

DATE OF PURCHASE: _____

Important

DO NOT RETURN PRODUCT TO STORE

For all questions, comments, or inquiries, please contact Dansons Customer Care department.

USA: (480) 923-9637
service@surelock-security.com



602210924UVM

 **WARNING:** THIS PRODUCT CAN EXPOSE YOU TO CHEMICALS INCLUDING DI (2-ETHYLHEXYL) PHTHALATE (DEHP) WHICH IS KNOWN TO THE STATE OF CALIFORNIA TO CAUSE CANCER AND BIRTH DEFECTS OR OTHER REPRODUCTIVE HARM. FOR MORE INFORMATION GO TO: WWW.P65WARNINGS.CA.GOV

MADE IN CHINA