



# **KING KOOKER**

## **OUTDOOR COOKERS**



**12013N, 1316N, SS1316N AND 9013N**

# **ASSEMBLY INSTRUCTIONS AND USE AND CARE MANUAL**

**MODEL/SERIAL # \_\_\_\_\_**

**THE INSTRUCTION MANUAL CONTAINS IMPORTANT INFORMATION  
NECESSARY FOR THE PROPER ASSEMBLY AND SAFE USE OF THE APPLIANCE.  
READ AND FOLLOW ALL WARNINGS AND INSTRUCTIONS BEFORE  
ASSEMBLING AND USING THE APPLIANCE. FOLLOW ALL WARNINGS AND  
INSTRUCTIONS WHEN USING THE APPLIANCE.  
KEEP THIS MANUAL FOR FUTURE REFERENCE.**



### ***METAL FUSION, INC.***

712 St. George Avenue.

Jefferson, LA 70121

If you have any problems or questions

**Call Us Toll Free at**

**1-800-783-3885**

**7:30 AM to 3:30 P.M. CST • Monday through Friday**

**(504) 736-0201**

**www.kingkooker.com**

## **▲WARNING**

**FAILURE TO FOLLOW THESE INSTRUCTIONS  
AND WARNINGS COULD RESULT IN FIRE, EXPLOSION, BURN HAZARD OR  
CARBON MONOXIDE POISONING WHICH COULD CAUSE PROPERTY DAMAGE,  
PERSONAL INJURY OR DEATH.**

 **DANGER**

**If you smell gas:**

- 1. Shut off gas to the appliance.**
- 2. Extinguish any open flame.**
- 3. If odor continues, keep away from the appliance and immediately call your Fire Department.**

**FAILURE TO FOLLOW THESE INSTRUCTIONS COULD RESULT IN FIRE OR EXPLOSION WHICH COULD CAUSE PROPERTY DAMAGE, PERSONAL INJURY OR DEATH.**

 **DANGER**

- 1. Never operate this appliance unattended.**
- 2. Never operate this appliance within 10 feet (3.05m) of any structure, combustible material or other gas cylinder. Do not locate this appliance under ANY overhead construction.**
- 3. Only use propane burning units outdoors. Risks include fire and carbon monoxide fumes. Lack of ventilation can cause injury or death.**
- 4. Never operate this appliance within 25 feet (7.5m) of any flammable liquids or vapors.**
- 5. Do not fill cooking vessel beyond maximum fill line (if applicable).**
- 6. Heated liquids and equipment remain at scalding temperatures long after the cooking process. Never touch cooking appliance until liquids have cooled to 100°F (38°C) or less.**
- 7. If a fire should occur, keep away from the appliance and immediately call your Fire Department. Do not attempt to extinguish an oil/grease fire with water. When cooking, have a Type BC or ABC fire extinguisher readily available. A Type BC or ABC fire extinguisher may, in some circumstances, contain the fire.**

**FAILURE TO FOLLOW THESE INSTRUCTIONS AND WARNINGS COULD RESULT IN FIRE, EXPLOSION, BURN HAZARD OR CARBON MONOXIDE POISONING WHICH COULD CAUSE PROPERTY DAMAGE, PERSONAL INJURY OR DEATH.**

# **⚠️ WARNING**

## **READ AND UNDERSTAND BEFORE USING THIS PRODUCT**

Throughout this manual the words appliance, cooker, boiler, burner and stove will be used interchangeably to refer to the King Kooker® Outdoor Cooker.

- 1) This is an **ATTENDED** appliance. Do **NOT** leave this appliance unattended while the burner is lit or while heating water or cooking food. Monitor the appliance when hot after use [water above 100°F (38°C)]. Heated liquid and equipment can remain at scalding temperatures long after cooking has ended.
- 2) Keep children, pets and unauthorized persons away from the appliance at all times.
- 3) The use of alcohol, prescription or non-prescription drugs may impair your ability to properly assemble or safely operate this appliance. Do **NOT** assemble or operate this appliance if using alcohol, prescription or non-prescription drugs.
- 4) This appliance is for **OUTDOOR** use only. Do **NOT** use in a building, garage, tent or any other enclosed area. Do **NOT** use in or on a recreational vehicle or boat. **NEVER** use this appliance as a heater.
- 5) Do not locate this appliance under **ANY** overhead construction. Keep a minimum clearance of 10ft. (3.05m) from the sides, front and back of the appliance to **ANY** construction. Keep the area clear of **ANY** combustible material. Do not use on or under **ANY** apartment or condo balcony or deck.
- 6) When cooking, the appliance must be on a level, stable noncombustible surface such as brick, concrete or dirt. Not suitable are surfaces such as wood, asphalt or plastic which may burn, blister or melt.
- 7) Check all cooker fittings for leaks before each use. Do not use a flame to check for gas leaks. Keep the fuel supply hose away from any heated surfaces. Only the LP hose/regulator assembly specified by Metal Fusion, Inc. should be used with this appliance.
- 8) This appliance is only intended for heating water (not oil or grease.) This appliance is not for frying.
- 9) **NEVER** overfill the cooking pot with water. Follow instructions in this manual for establishing proper water levels.
- 10) Never drop food or accessories into hot cooking liquid. Lower food and accessories slowly into the cooking liquid in order to prevent splashing or overflow. When removing food from the appliance, care shall be taken to avoid burns from hot cooking liquids.

- 11) This appliance and pot, including handles and lids, gets dangerously hot in use. Use well-insulated pot holders or oven mitts for protection from hot surfaces or splatter from cooking liquids. Safety goggles are also recommended to protect you from splatter. The water remains dangerously hot hours after use.
- 12) Do NOT place an empty cooking vessel on the appliance while in operation. Use caution when placing anything in the cooking vessel while the appliance is in operation. Never use a cooking vessel larger than the capacity and diameter specified in this manual.
- 13) In the event of rain, snow, hail, sleet or other forms of precipitation while cooking, cover the cooking vessel immediately and turn off the appliance burners and gas supply. Do not attempt to move the appliance or cooking vessel.
- 14) Do NOT move the appliance when in use. Allow the cooking vessel to cool to 100°F (38°C) before moving or storing.
- 15) Avoid bumping of or impact with the appliance to prevent contact with hot appliance, spillage or splashing of hot cooking liquid.
- 16) See Use and Care section for LP Gas Cylinder Information. A 20 pound (9 kg) cylinder should be used with this cooker. The LP-gas supply cylinder used must have a protective collar and must be constructed and marked in accordance with the specifications for LP-gas cylinders of the U. S. Department of Transportation (DOT) or the National Standard of Canada, *CAN/CSA-B339, Cylinders, Spheres and Tubes for the Transportation of Dangerous Goods*. Do not store a spare LP-gas cylinder under or near this appliance. Never fill the cylinder beyond 80% full. For proper vapor withdrawal, the 20 lb. (9 kg) cylinder should be used in the proper upright position. Cylinder must be turned off while not in use. Failure to follow these instructions and warnings could result in fire or explosion which could cause property damage, personal injury or death.
- 17) This appliance is not intended for commercial use.
- 18) Use King Kooker® appliances only in accordance with state and local ordinances, or in the absence of local codes, with the National Fuel Gas Code, *ANSIZ223.1/NFPA 54, Storage and Handling of Liquefied Petroleum Gases, ANSI/NFPA 58 or CSA B149.1, Natural Gas and Propane Installation Code*.

## **⚠ WARNING**

**FAILURE TO FOLLOW THESE INSTRUCTIONS AND WARNINGS COULD RESULT IN FIRE, EXPLOSION, BURN HAZARD OR CARBON MONOXIDE POISONING WHICH COULD CAUSE PROPERTY DAMAGE, PERSONAL INJURY OR DEATH.**

**READ AND UNDERSTAND ALL INSTRUCTIONS BEFORE  
USING YOUR KING KOOKER® PRODUCT**

**TABLE OF CONTENTS**

**Warnings** ..... 2-4

**Table of Contents** ..... 5

**Warranty** ..... 6

**Owners Registration** ..... 7-8

**Section I - Outdoor Cooker Assembly** ..... 9

    Assembly Instructions ..... 10

    Hose Assembly Instructions ..... 10

**Section II - Use and Care** ..... 11

    Determining Proper Fill Levels for Cooking Vessels ..... 11

    LP Gas Cylinder Information ..... 11

    Connection Instructions ..... 12

    Leak Test Instructions ..... 12

    Placement Instructions ..... 13

    Lighting and Operating Instructions ..... 14

    Turning Off and Storing the Cooker After Use ..... 15

    Maintenance of Outdoor Cookers and Accessories ..... 15

    Caring for Aluminum and Cast Iron Cookware ..... 16

**Section III - Recipes** ..... 17

    Boiled Seafood ..... 17

    Steamed Clams and Mussels ..... 17

    Steamed Crab, Shrimp, and Lobster ..... 17

**Section IV - Frequently Asked Questions and Answers** ..... 18

Congratulations on your purchase of your King Kooker® Outdoor Cooker. You will be delighted with the variety of dishes you can prepare with your cooker. Use your imagination and you can be a gourmet chef, surprising your friends and family with the wonderful meals you will prepare. We have provided a few recipes on our website - **www.kingkooker.com** - to get you started. There are a wide variety of seasonings/marinades available to experiment with and enjoy.

Cook with your King Kooker® and EAT LIKE A KING!

# METAL FUSION, INC.

## LIMITED ONE-YEAR WARRANTY

### WHAT THIS WARRANTY COVERS

This warranty covers all components of this outdoor cooker to be free from defects in materials and workmanship, with the exceptions stated below.

### HOW LONG COVERAGE LASTS

This warranty runs for one year from the date of purchase. Please keep your receipt with this manual for future reference.

### WHAT IS NOT COVERED

This warranty does not cover the following:

***Incidental and Consequential Damages.*** This warranty does **not** cover incidental and consequential damages arising in any way out of the use of this outdoor cooker. The liability of Metal Fusion, Inc. is, in any event, limited to the amount of the original purchase price of this outdoor cooker, and remains in force only as long as the product remains in its original, as-built configuration. Some states do not allow the exclusion or limitation of incidental or consequential damages, so the above limitation or exclusion may not apply to you.

***Neglectful Operation.*** This warranty does **not** cover any loss or damage arising in any way due to the negligent operation of this outdoor cooker.

***Altered, Repaired or Misused Equipment.*** This warranty does **not** cover any loss or damage arising in any way out of the use of this outdoor cooker when it has been altered, repaired by persons other than Metal Fusion, Inc., or when it has been abused or misused, or when it has been used other than in accordance with the manufacturer's operating instructions, including, without limitation, any damage to the consumer's pots because they were placed on a lit cooker while the pot is empty.

***Other Assumed Responsibilities.*** Unless otherwise provided by law, this warranty does **not** cover any responsibility or liability arising in any way out of the use of this product where that responsibility or liability was purportedly assumed by any other person or agent.

***Paint, Discoloration, and Rust.*** This warranty does **not** cover the paint on the outdoor cooker, as in a normal use of the outdoor cooker, the paint will be burned off. Nor does this warranty cover discoloration or rust to the cooker as these occurrences are part of the cooker's normal wear and tear.

### WHAT METAL FUSION, INC. WILL DO

Metal Fusion, Inc. will repair or replace any outdoor cooker that proves to be defective in materials or workmanship. In the event repair is not possible or economically feasible, Metal Fusion, Inc. will replace your outdoor cooker with an identical or substantially equivalent outdoor cooker. Metal Fusion, Inc. will perform this service at no charge to you, except for the actual cost of shipping and handling the outdoor cooker or replacement parts.

### HOW TO GET SERVICE

In the event you have a problem or malfunction with your outdoor cooker, simply call Metal Fusion, Inc. at (800) 783-3885.

### HOW STATE LAW APPLIES

This warranty gives you specific rights, and you may have other rights which vary from state to state.

# OWNER'S REGISTRATION



Dear Customer,

Thank you for purchasing a King Kooker®! Please take a moment to fill out your registration form and return it to us. We are always happy to hear suggestions and comments from our customers about our products. Completion of this registration allows us to contact you if the need arises. Please keep your receipt with your instruction manual. It will be necessary as a proof of purchase for us to help you if there is a problem with your cooker.

Name: \_\_\_\_\_

E-Mail: \_\_\_\_\_

Address: \_\_\_\_\_

\_\_\_\_\_

\_\_\_\_\_

Telephone: \_\_\_\_\_

Model# \_\_\_\_\_

Date of Purchase \_\_\_\_\_

Place of Purchase \_\_\_\_\_

Price Paid \_\_\_\_\_

Was this a gift \_\_\_\_\_ or did you \_\_\_\_\_ purchase it yourself?

\_\_\_\_\_

\_\_\_\_\_

Comments: \_\_\_\_\_

\_\_\_\_\_

\_\_\_\_\_

A SATISFIED CUSTOMER IS OUR MAIN GOAL. If you have any questions or problems, please call us at 1-800-783-3885 before returning the product to the point of purchase. Please have your receipt available when calling.

**THANK YOU,  
ENJOY YOUR COOKING EXPERIENCE.**

TAPE HERE

FOLD

---



Place  
Stamp  
Here

**METAL FUSION, INC.**  
712 St. George Avenue  
Jefferson, LA 70121

FOLD

---



# SECTION I OUTDOOR COOKER ASSEMBLY

## **⚠ WARNING**

### **THE USE AND CARE MANUAL MUST BE READ AND UNDERSTOOD BEFORE USING THE APPLIANCE**

Throughout this manual the words appliance, cooker, boiler, burner and stove will be used interchangeably to refer to the King Kooker® Outdoor Cooker.

---

## **TOOLS REQUIRED:**

**SCREWDRIVER, TORQUE WRENCH or ADJUSTABLE WRENCH, LEAK TESTING SOLUTION**

1. Before assembling, check that all cooker components are included in the shipping carton. Identify these cooker parts from the assembly drawing. Accessories may vary according to model. Check the list of accessories on your cooker box. The following parts are considered essential and should be included in your package.

### **Required Parts Lists:**

#### **Cooker Stand, Heat Plate, LP Hose and Regulator**

If any of the above parts are missing, contact Metal Fusion, Inc. at 1-800-783-3885 between the hours of 7:30 a.m. and 3:30 p.m. CST Monday through Friday for replacements.

2. Read assembly instructions, and understand sequence of assembly, before commencing to assemble your cooker.
3. After reviewing assembly instructions, go to the **Use and Care** section of this manual for further instructions.

# ASSEMBLY INSTRUCTIONS

1. Locate the three separate heat plate pieces. Lay the plates on a flat surface as shown in Figure 1. Place the rounded inner edge of one plate against the vertical jet pipe. The bottom of the plate should be located above the the prongs when installed (3 prongs welded to side of jet pipe.) The plate will fit around the appliance leg using the cutouts provided on the plate. Repeat procedure with the second plate. Align the bolt holes of the first and second plates and attach with bolt, lock washer and nut. Repeat procedure with the third plate. Tighten all bolts/nuts. Reference Figure 2 and Figure 3 for picture of heat plate assembly.

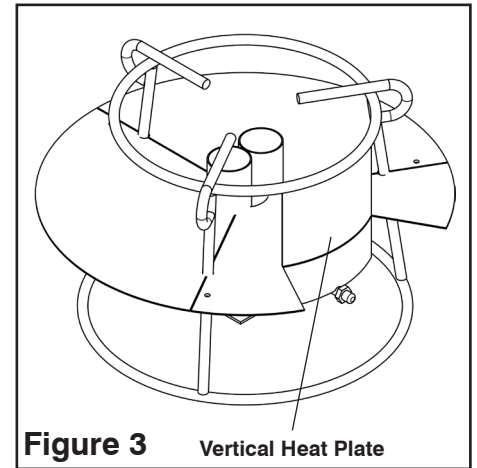
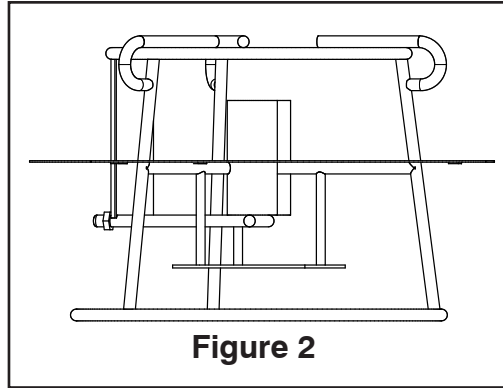
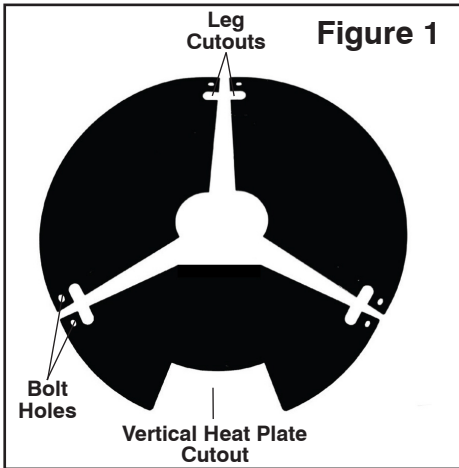

# HOSE ASSEMBLY INSTRUCTIONS

1. Wrench tighten the 3/8" female flare swivel to the brass adapter.
2. The hose to burner (brass adapter) connection must be tightened and leak tested.
3. Go to the **Use and Care Section** of this manual for further instructions.

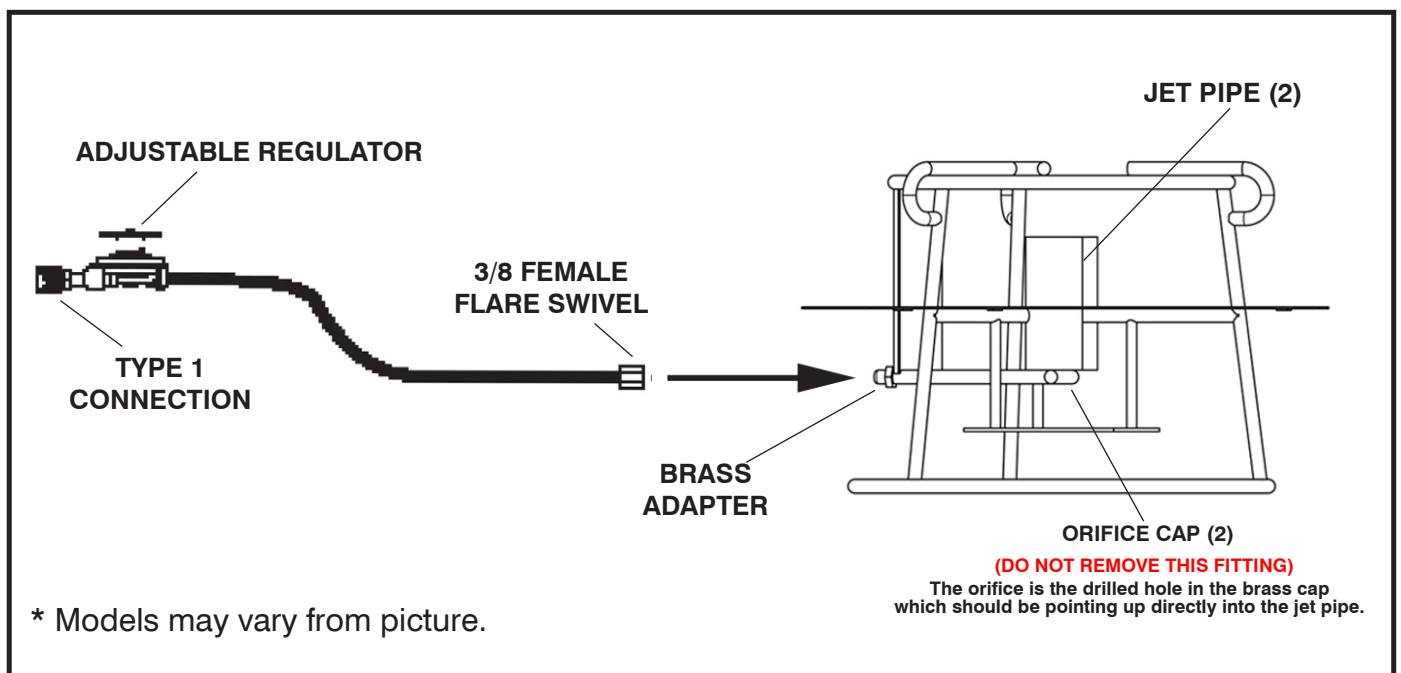

# SECTION II

## USE AND CARE

Throughout this manual the words appliance, cooker, boiler, burner and stove will be used interchangeably to refer to the King Kooker® Outdoor Cooker.

### **▲WARNING**

**READ AND UNDERSTAND BEFORE USING THIS APPLIANCE  
FAILURE TO FOLLOW THESE INSTRUCTIONS AND WARNINGS COULD RESULT IN FIRE,  
EXPLOSION, BURN HAZARD OR CARBON MONOXIDE POISONING WHICH COULD CAUSE  
PROPERTY DAMAGE, PERSONAL INJURY OR DEATH.**

## DETERMINING PROPER FILL LEVELS FOR COOKING VESSELS

This appliance is only intended for heating water (not oil or grease.) This appliance is not for frying.

Never overfill the cooking vessel with water. Never fill a pot beyond the maximum fill line. If the pot being used does not have a maximum fill line, follow these instructions to determine the amount of cooking liquid to be used:

- a. Place the food product in or on the holder.
- b. Place the food product and holder into the empty vessel.
- c. Fill the vessel with water just until the food product is completely submerged. There must be a minimum of 3 inches (7.5 cm) between the water level and top of the vessel.
- d. Remove the food product from the vessel and either mark the water level on the side of the vessel or measure the amount of water in the vessel.
- e. Remove the water and completely dry the vessel and the food product.
- f. This is the amount of cooking liquid the vessel is to be filled with to cook the food product.

## LP GAS CYLINDER INFORMATION

King Kooker® Outdoor Cookers are manufactured for use with **20lb. (9 kg) LP Gas Cylinders**. Important information to remember about LP Gas cylinders include:

1. Always read and follow the cylinder manufacturer's instructions.
2. Make sure that the gas cylinder is not overfilled. The maximum weight of a properly filled 20 lb. (9 kg) LP gas cylinder is approximately 38 lbs (17 kg). Never fill the cylinder beyond 80% full.
3. Make sure that the cylinder valve has the proper connection for a Type 1 appliance fitting.
4. Do not store a spare LP gas cylinder under or near this appliance.
5. Disconnect the cylinder from the cooker for storage.
6. Store the cylinder out of the reach of children.
7. Do not use or store the cylinder in a building, garage or enclosed area.
8. Always use a 20 lb. (9 kg) cylinder in the proper upright position for the proper vapor withdrawal. It should also be stored and transported in the upright position.
9. The cylinder must have a protective collar to protect the cylinder valve.
10. Place dust cap on cylinder valve outlet whenever the cylinder is not in use. Only install the type of dust cap on the cylinder valve outlet that is provided with the cylinder valve. Other types of caps or plugs may result in leakage of propane.
11. Cylinder must be turned OFF while not in use.

### **▲WARNING**

**ALWAYS READ AND FOLLOW THESE AND THE CYLINDER MANUFACTURER'S INSTRUCTIONS. FAILURE TO FOLLOW THESE INSTRUCTIONS AND WARNINGS COULD RESULT IN FIRE, EXPLOSION, BURN HAZARD OR CARBON MONOXIDE POISONING WHICH COULD CAUSE PROPERTY DAMAGE, PERSONAL INJURY OR DEATH.**

# CONNECTION INSTRUCTIONS

1. Check that your hose assembly valve is set to not allow gas flow. Turn the regulator control counterclockwise until it stops. This is the OFF position.
2. Attach the regulator to the cylinder valve by turning the Type 1 fitting clockwise. Hand tighten with the regulator positioned upright. Refer to the assembly diagram for the appliance below.

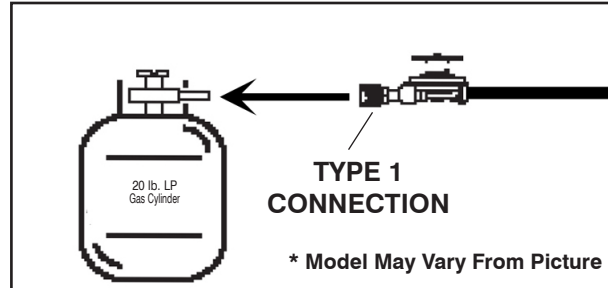

3. Perform the Leak Test:

## LEAK TEST

Before lighting the appliance, a thorough leak test must be satisfactorily completed using a non-ammonia soapy water solution (50% non-ammonia soap and 50% water). This is to be applied with a small brush to all gas joints after the cylinder valve is opened (no more than 1/2 turn). If bubbles are seen, indicating a leak, turn off the cylinder and tighten the leaking connection until a further leak test shows no leaks.

If tightening the connection does not stop the leak, call Metal Fusion, Inc. (800) 783-3885, for assistance.

**NEVER USE HOSE/REGULATOR ASSEMBLY IF LEAKING.**

4. Before lighting the cooker, check that the jet pipes and orifice(s) are free from obstruction. The orifice(s) under the jet tube should be positioned pointing up directly through the tube as per Figure 1. Both situations must be corrected if necessary before lighting to prevent flashback.

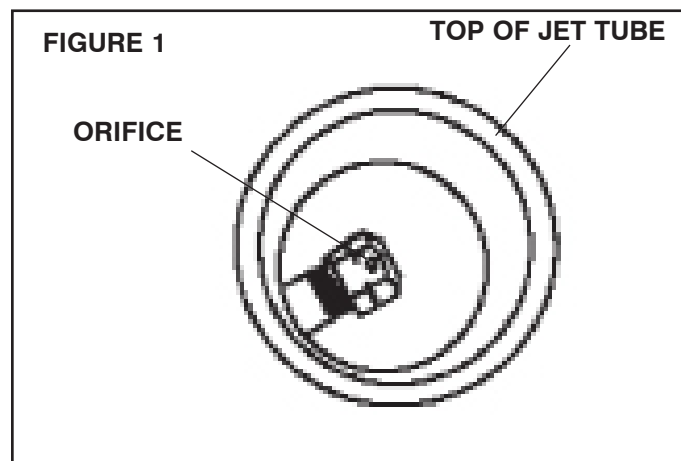

# PLACEMENT INSTRUCTIONS

1. Never operate this appliance within 10ft. (3.05m) of any structure, combustible material or other gas cylinder. Never operate this appliance within 25ft. (7.5m) of any flammable liquids or vapors
2. There must be no combustibles or roof overhead.
3. Keep 24 inches (.61 m) of space between the LP gas cylinder and the appliance.
4. The LP gas cylinder and appliance must be located so that any wind is blowing the heat of the appliance away from the propane cylinder. This also helps fire prevention by blowing the flames of a grease fire away from the propane cylinder.
5. Center the pot over the burner(s) on the cooker.  
Do NOT use any pot larger than 160 qts. (151.42 L) [21.5”H (54.61 cm) X 23.75”D (60.33 cm)].

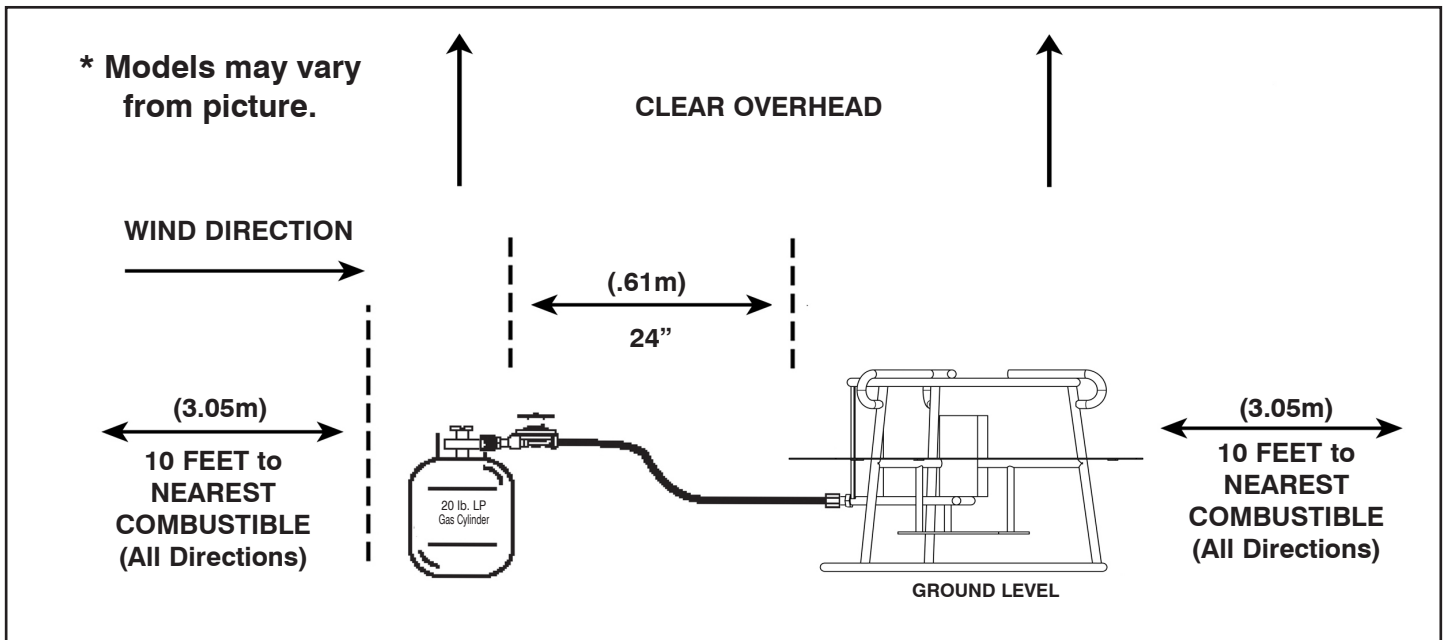

## **WARNING!**

Keep twenty-four inches between the cylinder and the appliance. Placing the cylinder too close to the appliance could result in fire or explosion which could cause property damage, personal injury or death.

The hose connecting the appliance to the tank poses a trip hazard. Do not step over the hose or walk between the cylinder and appliance. Tripping could cause the appliance or cylinder to tip over, leading to fire or explosion which could cause property damage, personal injury or death.

# LIGHTING AND OPERATING INSTRUCTIONS

## **⚠WARNING**

**THE COOKER MUST NOT BE LIT UNTIL THE PRECEDING PLACEMENT INSTRUCTIONS HAVE BEEN COMPLETELY FOLLOWED.**

1. Make certain that the regulator control is turned to OFF by turning it counterclockwise until it reaches the stop.
2. Open cylinder control valve by turning it counterclockwise as per the diagram (Figure 2).
3. Hold a multipurpose lighter as per Figure 4 or paperbook match as per Figure 3 over one of the jet pipes. Lighting one jet pipe will also ignite the other jet pipe.

**CAUTION: Do NOT place hands or face directly over the jet pipes when lighting.**

Turn the regulator control toward the ON position until ignition occurs. Turning the regulator control clockwise increases the gas pressure to the burner and hence the flame size (Figure 2).

When lighting the cooker, if ignition does not occur in 3 to 5 seconds, turn the regulator and cylinder valve off. Wait 5 minutes for gas to disperse. Repeat procedure. Refer to Figure 5 for proper flame emission.

4. Always monitor the flames throughout the cooking process. If at any point in the cooking process the flames are accidentally extinguished, immediately turn the regulator and cylinder valve OFF. Wait 5 minutes for gas to disperse and relight the cooker according to the lighting instructions. (#1 - #4) in this section.

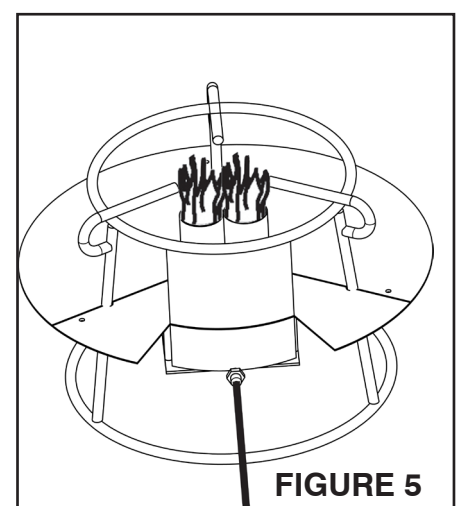
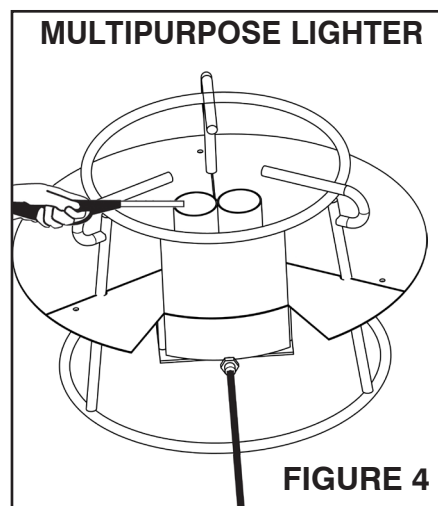
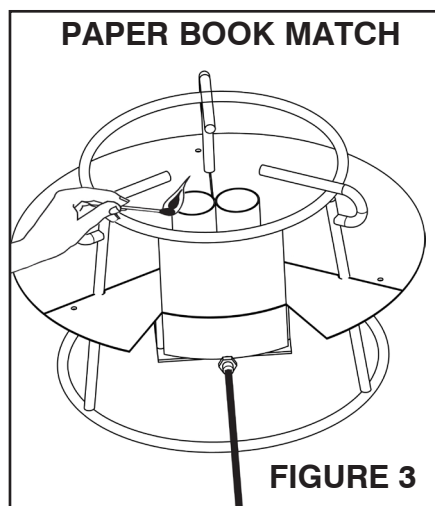
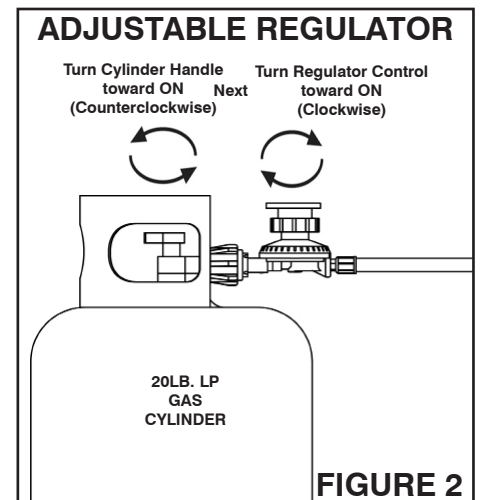
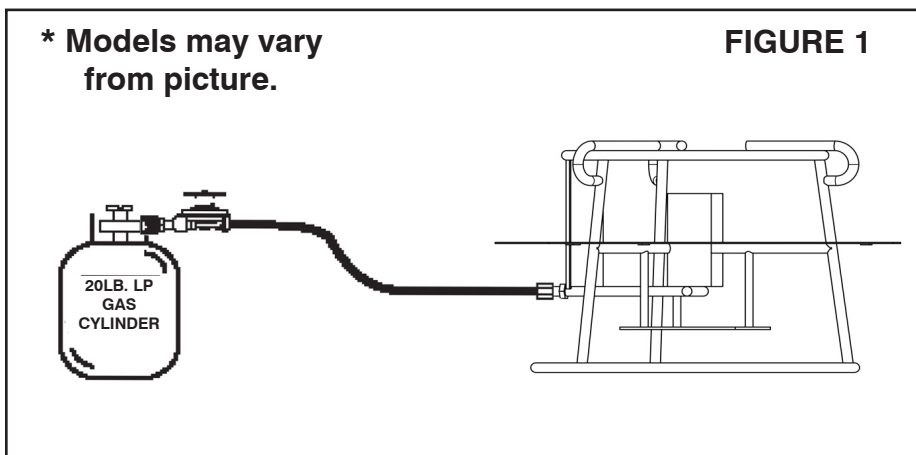

## **⚠WARNING**

**NEVER PUT HANDS OR FACE DIRECTLY OVER BURNER WHILE LIGHTING OR WHILE THE APPLIANCE IS LIT.**

## TURNING OFF AND STORING THE COOKER AFTER USE

### **⚠WARNING**

**NEVER MOVE THE COOKER OR POT WHILE IN USE OR STILL HOT [ABOVE 100°F(38°C)].**

1. After each use turn OFF the King Kooker® at the regulator first, then at the gas cylinder valve. **Check to make sure there is no flame and all valves are off.** Do not leave the cooker until it has cooled completely. When removing food from the cooker wear protective mitts.
2. Disconnect the regulator from the cylinder by turning the Type 1 fitting counterclockwise until the regulator is separated from the tank.
3. Storage of this cooker indoors is permissible only if the cylinder is disconnected and removed from the cooker. Do not use or store cylinder in a building, garage or enclosed area. Read and follow cylinder manufacturer's instructions. The cylinder must be stored out of the reach of children at all times. Keep entire unit in area to avoid insects and contamination that can clog the jet tube(s).

### **⚠WARNING**

**FAILURE TO FOLLOW THESE INSTRUCTIONS AND WARNINGS COULD RESULT IN FIRE, EXPLOSION, BURN HAZARD OR CARBON MONOXIDE POISONING WHICH COULD CAUSE PROPERTY DAMAGE, PERSONAL INJURY OR DEATH.**

---

## MAINTENANCE OF OUTDOOR COOKERS AND ACCESSORIES

1. The area where the cooker will be used must be kept clear and free from combustible materials, gasoline and other flammable vapors and liquids. Before each use of the cooker inspect and remove any combustible items.
2. The flow of combustion and ventilation of air must not be obstructed. The cooker must be set in an open area with 10ft. (3.05m) of space on all sides and no roof or overhang overhead. Check the location and placement of the cooker before each use.
3. Before each use of the appliance check the jet tubes for insects, insect nests, and other obstructions. A clogged tube can lead to a fire beneath the appliance.
4. Follow all Lighting Instructions in the Use and Care section each time the cooker is used. Check the flame for proper color and appearance. The flame should burn with a primarily blue color.  
If the jet burner flame does not appear correct, there may be an obstruction in the orifice (pg. 12.) Turn off the cooker and allow time for it to cool. Remove any obstructions in the orifice using a thin wire or pin. Light the cooker again as per the instruction manual. If this does not resolve the problem, please call Metal Fusion, Inc. at 1-800-783-3885.
5. Always use the LP Hose/Regulator assembly supplied with the appliance. Before each use of the appliance check the LP Hose for evidence of abrasion, wear, cuts or leaks. If there is any damage to the hose, the hose/regulator assembly must be replaced prior to using the appliance. Contact Metal Fusion, Inc. at (800) 783-3885 for information regarding a replacement hose assembly. Only the LP Hose/Regulator assembly specified by Metal Fusion, Inc. should be used with the appliance.
6. For purchase of any replacement parts which may have become damaged or lost, please contact Metal Fusion, Inc. at (800) 783-3885 between the hours of 7:30 am-3:30pm (CST) Monday through Friday.
7. Cleaning of the appliance:  
**Cooker and LP Hose/Regulator:** If necessary, remove any oil or liquid which has spilled onto the unit during cooking with mild soapy water on a rag and towel dry. Do not immerse the burner unit or hose and regulator into water as this will cause rust.  
**Aluminum or Stainless Steel Pots:** Clean after each use according to the directions on page 16.  
**Cast Iron Cookware:** Clean after each use according to the directions on page 16.



# TIPS FOR CARING FOR BOILING POTS

It is not necessary to season aluminum pots before cooking with them. Wash with a liquid dish washing detergent and towel dry.

After cooking, wash aluminum pots and pans in hot, sudsy detergent. If grease or black soot has cooked to the outside of the pot while cooking with your outdoor cooker, scrub the outside of the pot with a steel wool scouring pad.

**DO NOT SPRAY OVEN CLEANER ON ALUMINUM POTS TO REMOVE GREASE OR SOOT. OVEN CLEANER WILL CAUSE THE FINISH TO BECOME DULL.**

If food remains stuck in the pan after cooking, add hot water and let soak. Then scrub the pan with soap and steel wool to loosen the food.

If hard water causes darkening on the interior of your pot, fill to the level of the darkened area with a water and cream of tartar or vinegar solution (mixed with the concentration of three cups of water to one tablespoon cream of tartar, or vinegar). Boil five to ten minutes.

**NEVER PLACE AN EMPTY ALUMINUM OR STAINLESS STEEL POT ON A LIT COOKER.** A hole will be burned in the bottom of the pot. Discoloration, scratching, and dimpling may occur with the use of pots on outdoor cookers. This does not affect the performance of the pot.

Do not store used oil inside your aluminum pot. The salt used in cooking can corrode the pot causing the pot to leak. Wash the pot after each use with hot, soapy water and rinse.

## SEASONING & CARE OF CAST IRON COOKWARE

New Cast Iron Pots are coated with paraffin to prevent rusting. Before using for the first time, wash with mild soapy water, rinse, and dry thoroughly. Never use abrasive detergents. Grease the entire surface of the cookware with a thin coating of solid vegetable shortening. Do not use salted fat (margarine or butter). Heat for 30-60 minutes in oven at 300-350°F (149-177°C.) Remove from oven, pour out excess grease, and wipe with a paper towel. This completes the seasoning process. Each time the cast iron is used, coat the entire surface with a thin coat of solid vegetable shortening, wipe with a paper towel, and store.





# SECTION III RECIPES

from  
**The King of Outdoor Cooking™**

The following recipes are based on common food quantities and pot sizes used in outdoor cooking. Variations will occur dependent on food quantities and pot sizes being used. Adjust the recipes accordingly.



## **Boiled Seafood! The King Kooker® Way!**

For a 60 to 100 quart pot, fill 1/2 full of water. Add 4 to 6, 16 ounce King Kooker® Complete Crab, Shrimp, Crawfish Boil (complete, nothing to add). Bring water to a rolling boil. Add seafood. Gently stir. Cover the pot and return to boil. Boiling times: Shrimp - 2 minutes; Crawfish - 5 minutes; Crabs - 5 minutes. Cut off the fire. Gently stir the seafood again and let it soak. Add one 8 ounce King Kooker® Liquid Crab Boil. Soaking time: Shrimp - 15 to 20 minutes; Crawfish and Crabs - 15 to 20 minutes.

Seafoods tend to float on the surface while soaking. On the surface they do not thoroughly absorb the seasoning. Add the equivalent of four trays of ice to the pot, allowing it to float on the surface of the liquid. This sudden change of temperature causes the seafood to sink and to draw in the great flavor of King Kooker® seasoning.

### ***A Little Extra***

To complement your seafood, try including a few pounds of creamer potatoes, a dozen ears of corn, a pound of fresh mushrooms, five or six cloves of garlic, fresh peeled onions, hot dogs, smoked sausage or andouille sausage.

**Hint:** Allow potatoes extra cooking time by adding them to the boiling seasoned water 5 to 10 minutes before adding the seafood.

## **Steamed Clams or Mussels**

Clean clams thoroughly in cold water, scrubbing with a brush. Discard any that float. Place clams on steamer plate in basket. Pour enough water into pot to come up to bottom of steamer rack when in pot. Bring water to a boil and cover. The clams are cooked when the shells open. Any shells which do not open should be discarded. Remove from heat. Too much cooking will toughen the clams. Serve with drawn or melted butter.

## **Steamed Blue Crabs, Shrimp, or Lobsters**

Place water in the pot up to the bottom of the steaming plate. You can replace one half of a gallon of the water with 1/2 gallon of vinegar if you would like. Add 2 1/2 tablespoons of steamer seasoning and 3 tablespoons salt to water/vinegar mixture. Place the steamer rack into the pot and layer the seafood on the steamer rack, sprinkling each layer generously with steamer seasoning. Salt to taste. Cover and steam until crabs or lobsters turn red (approximately 20-25 minutes). Steam shrimp (approximately 10-15 minutes), the meat will pull away from the shell when done. For extra flavor pour two ounces of King Kooker® Liquid Crab Boil into the water/vinegar mixture. (Make sure to never allow all of the steaming liquid to evaporate. A hole will be burned into the bottom of an empty pot on a lit cooker.)

***We recommend King Kooker® Complete Crab, Shrimp, Crawfish Boil to add flavor to all your steamed seafoods and vegetables.***

# SECTION IV

## READ AND UNDERSTAND ALL INSTRUCTIONS BEFORE USING YOUR KING KOOKER® PRODUCT

### FREQUENTLY ASKED QUESTIONS AND ANSWERS

---

1. **What is the problem if the cooker takes too long or will not heat oil or cooking ingredients to desired temperature? My cooker's flame appearance is very weak.**

Answer: If the hose assembly has a Type 1 Connection (black/green knob), it is equipped with a flow limiting device. This device is intended to limit the flow of gas should there be a leak between the regulator and the appliance. To achieve a positive gas seal, which will allow for maximum gas flow, the regulator control must be set to a completely OFF position before the cylinder valve is opened. A good tip to remember is "TANK IS FIRST ON, LAST OFF."

The Problem Can Be Remedied in Two Ways:

- A.
1. Turn the regulator control to the OFF position. Close the tank valve completely by turning it clockwise until it stops.
  2. Check that the Type 1 Connection (black/green knob) is completely tightened to the tank valve.
  3. Wait 5 seconds for the pressure to equalize and for the flow limiting device to reset.
  4. Turn tank valve ON (counterclockwise.)
  5. Turn the regulator control to an ON position.
  6. Relight cooker following all lighting instructions contained in this manual. Check for proper flame characteristics.

**OR**

- B.
1. Turn the regulator control to the OFF position. Close the tank valve completely by turning it clockwise until it stops.
  2. Remove Type 1 Connection (black/green knob) from the tank valve. The flow limiting device will now reset.
  3. Re-attach Type 1 Connection (black/green knob) to the tank valve. Tighten completely.
  4. Turn tank valve ON (counterclockwise.)
  5. Turn the regulator control to an ON position.
  6. Relight cooker following all lighting instructions contained in this manual. Check for proper flame characteristics.

2. **How long will the propane in my tank last?**

Answer: On average, a full tank will give you 4 to 5 hours of normal cooking.

3. **I have a new style tank and it won't connect to my regulator. What do I do?**

Answer: The regulator supplied with this appliance has a Type 1 Connection which will attach to the tank valve which has large threads on the valve outlet. These connect into the large plastic handnut (black or green). This tank will also connect to earlier models of Metal Fusion cooker regulators which had a brass plug connector with left hand threads, which will connect to the internal threads of the Type 1 tank valve (with a wrench). If your tank has a quick disconnect valve (plug in type) our regulators can not connect to this tank.

4. **I have a brand new cooker and I cannot get the burner to light. What's the problem?**

Answer: Make sure the tank has been filled with propane. Tanks purchased from the store shelf are most often sold empty. If this does not solve the problem refer to Maintenance Instruction items #3 and #4, page 15. If you have questions please call Metal Fusion, Inc. at (800) 783-3885.

**IF YOU HAVE A QUESTION WE HAVE NOT ADDRESSED IN THIS MANUAL  
PLEASE SEND US AN E-MAIL AT [info@kingkooker.com](mailto:info@kingkooker.com) OR CALL 1-800-783-3885  
BETWEEN 7:30 A.M. AND 3:30 P.M. CST MONDAY THROUGH FRIDAY.**



# Outdoor Cooker Safety Precautions



# WARNING!

FAILURE TO FOLLOW THESE INSTRUCTIONS AND WARNINGS COULD RESULT IN FIRE, EXPLOSION, BURN HAZARD OR CARBON MONOXIDE POISONING WHICH COULD CAUSE PROPERTY DAMAGE, PERSONAL INJURY OR DEATH.

Read and understand the entire Assembly Instructions and Use and Care Manual before using this product. If you lose your manual and need a replacement, or have questions, please contact us at 1-800-783-3885 between the hours of 7:30 A.M. and 3:30 P.M. CST Monday-Friday, or go to [www.kingkooker.com](http://www.kingkooker.com)

 **WARNING:** This product can expose you to chemicals including lead, known to the State of California to cause cancer, birth defects, or other reproductive harm. For more information go to [www.P65Warnings.ca.gov/product](http://www.P65Warnings.ca.gov/product)



**USE ONLY OUTDOORS!**



**DO NOT** use under any overhang or roof. Keep a minimum clearance of 10 ft. (3.05m) on all sides of the cooker.



**DO NOT** use on combustible surfaces.



**ALWAYS** keep children, pets and any unauthorized persons away from cooker.



**ALWAYS** wear protective mitts and use extreme caution not to splash hot water.



**ALWAYS** turn the burner **OFF** when cooking is completed.



**ALWAYS** wear shoes while cooking. Keep hair and clothing from coming into contact with the cooker while in use or still hot.



**NEVER LEAVE COOKER UNATTENDED** while in use or still hot.

KING GRILLERDINE®, KING KOOKER®, the KING KOOKER® logo, THE KING®, THE KING OF OUTDOOR COOKING®, MR. OUTDOORS®, and WATCHDOG OUTDOOR COOKER SERIES® are trademarks of Metal Fusion, Inc., 712 St. George Avenue, Jefferson, LA 70121