



The **WM. MALCOLM**[®] 6X Two-Tone Rifle Telescope Owner's Manual



WARNING:

It is absolutely necessary to securely mount the scope to your rifle. The front and rear scope mounts require installation using the provided 60° dovetail bases or equivalent bases. This should be done by a competent gunsmith and will often require drilling and tapping your barrel. Failure to follow this procedure can result in serious personal injury.

Contact Information:

Hi-Lux Optics

3135 Kashiwa Street

Torrance, CA 90505

Tel: (310) 257-8142, Fax: (310) 257-8096

E-mail: info@hi-luxoptics.com

Website: <http://www.hi-luxoptics.com>

Technical Support: info@hi-luxoptics.com

© 2020 Hi-Lux, Inc.; Leatherwood[®] & Malcolm[®] are the trademarks of Hi-Lux, Inc.

THANK YOU for purchasing the Wm. Malcolm short rifle telescope manufactured by Leatherwood Hi-Lux Optics.

Since very little is generally known about early telescopic sights, a little history is in order to understand where the Wm. Malcolm short telescopic sight fits in.

Good terrestrial telescopes were being built by the early 1700's. These had all the optical quality that was necessary for a rifle telescope. However it was not until the mid 1800s that rifles became sufficiently accurate to require a telescopic sight. The problem then became how to mount the scope so that it could be zeroed to the rifle.

In 1855, William Malcolm started building 'Rifle Telescopes'. He understood that a riflescope must be properly constructed to hold zero. He made his scope tubes by boring them from solid bar stock, the same procedure as was used to build rifle barrels. The lenses were mounted on separate housings, securely fastened to the scope tube.

His first mounts followed the pattern that was written about by John Chapman in his book published in 1844. This pattern was used by many early riflescope builders. The elevation adjustment was a simple threaded post in the rifle tang.

At some point (probably after the Civil War), Malcolm devised a new solution to more precisely adjust elevation. He built a "rabbit ear" type mount that was located where the rear sight was usually positioned. This was much more robust than the previous designs and could be precisely adjusted either by a vernier scale or a scale-and-micrometer screw system. Additionally, he assembled his scopes to withstand the recoil of the heavier calibers.

Between the opening of the West and the death of the great Buffalo herds, Malcolm's scopes saw it all.

As repeating rifles appeared and the need for long-range single shot rifles were on the wane, short scopes in new styles of mounts began to appear. By the turn of the century, Malcolm was primarily producing this new type of scope. Our Malcolm short rifle telescopes are based on a design that continued to see use even during WWII. By the turn of the 20th Century, Malcolm had become the leading scope

manufacturer in the U.S. The company continued in business until WWII, even though some new optical technologies had been developed in Europe which would make these types of scopes obsolete. However, Americans would still carry this later type of Malcolm scope into combat during WWII. Descendents of these scopes, such as the Unertl, were used in armed conflicts as late as Vietnam.

Our Wm. Malcolm vintage scopes are constructed in the same manner as the original, sharing the authentic look and feel of the original scopes. While the aesthetics and mechanical functionality of our Wm. Malcolm scopes are reminiscent of the original, the optical performance is much improved due to the fully multicoated HD lenses, and the mechanical performance is improved by advancements in metallurgy.

TABLE OF CONTENTS

Section 1.	Riflescope Specifications	page 4
Section 2.	Basic Definitions and Adjustments	page 4
Section 3.	Adjusting the Wm. Malcolm Short Rifle Telescope	page 6
Section 4.	Mounting the Wm. Malcolm Short Rifle Telescope on the Rifle	page 7
Section 5.	Sighting in the Wm. Malcolm Short Rifle Telescope	page 7
Section 6:	Removing the Wm. Malcolm Short Rifle Telescope Mounts	page 10
Section 7:	DiamondTuff Guarantee	page 10

Section 1: Riflescope Specifications

Model	Power	Obj. (mm)	F.O.V.@ 100 Yds (Feet)	Eye Relief (Inch)	Length (Inch)	Weight (O.Z.)	Exit Pupil Range (mm)	Tube Size
M634181-B	6X	17	12	4.5	18	18	2.8	3/4"

All the air-glass surfaces are fully multi-coated with our proprietary DiamondTuff14 to maximize light transmission. The minimum focusing distance is 10 yards and the parallax distance is set at 100 yards.

The reticle is a fine crosswire. The rear mount is a Caged Type Mount with windage and elevation adjustment built in. The main tube is 3/4" in diameter.

The scope is a shockproof, waterproof and nitrogen purged at the factory.

Section 2: Basic Definitions and Adjustments

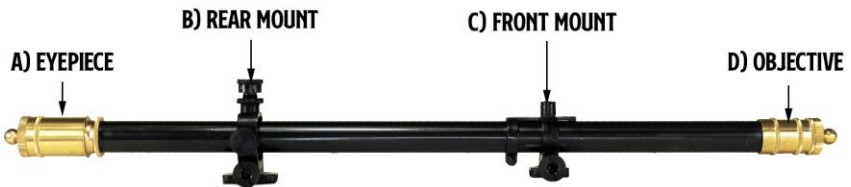

A. Eyepiece:

The eyepiece is at the rear end of the scope. A knurled locking ring secures the eyepiece's position on the threads. You can change the scope's focus to suit your individual eyesight. Loosen (turn clockwise)

the knurled locking ring, and turn the eyepiece clockwise or counter-clockwise until you are comfortable with the focus. Then, tighten the locking ring snugly to the eyepiece. Tighten the locking ring finger tight only.

B. Rear Mount:

The windage and elevation adjustments are located on the Rear Mount. It has the standard 60-degree type dovetail groove and a locking thumbscrew.

C. Front Mount:

The front mount provides a precise pivot system for the scope. It has the standard 60-degree dovetail groove and locking screw. There is a slide lock ring attached with the front mount to reduce the amount of recoil forces traveling through the scope. After every shot, the scope will need to be pulled back. This is called "resetting the scope to battery".

D. Objective:

The Objective is at the end of the scope opposite of the Eyepiece. Light enters the optic through the objective lens.

E. Standard 60° type dovetail base

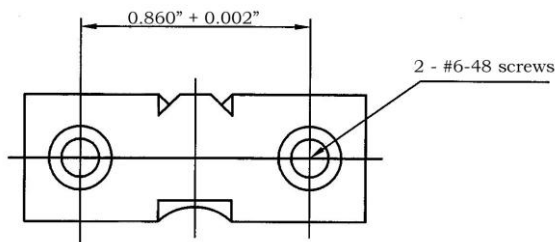

The scope comes with two standard 60-degree dovetail bases. The hole spacing is 0.860" from center to center. Unertl bases or other 60-degree bases should work with the provided scope mounts. The dovetail slot in the mounts is 1/2 inch wide.

Section 3: Adjusting the Short "Wm. Malcolm" Telescopic Riflescope

The Wm. Malcolm short scope is designed to replicate the look of the scopes that were popular during the Civil War era and continued in use until WWII. We have built the Malcolm scopes using best practices in optical manufacturing, from fully multi-coating glass lenses to nitrogen purging, to give the modern shooter a fun and dependable scope.

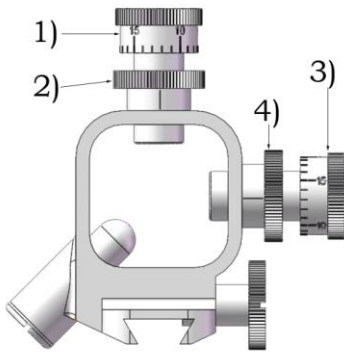

Rear Mount

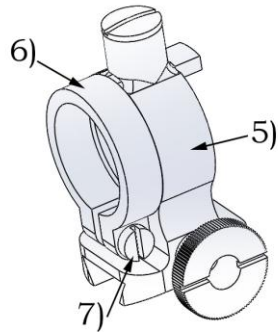

Front Mount

Don't let the external adjustments of the Short Wm. Malcolm mounts intimidate you. It will only take a few minutes to understand the relationship between the front and rear mounts. You'll find that making sight adjustments with the rear mount is actually every bit as easy as making sight adjustments with the standard open sights that probably came installed on your rifle. In fact, the movements of all adjustments with these mounts have the same exact effect on the point of impact as the same adjustments made with standard open sights.

The rear mount offers adjustments for both windage and elevation. When the **WINDAGE TURRET (3)** is turned **COUNTER-CLOCKWISE**, the point of impact moves to the **RIGHT**. When the **WINDAGE TURRET (3)** is turned **CLOCKWISE**, the point of impact moves **LEFT**.

When the **ELEVATION TURRET (1)** is turned **COUNTER CLOCKWISE**, the point of impact moves **UPWARD**. When the **ELEVATION TURRET (1)** is turned **CLOCKWISE**, the point of impact moves **DOWNWARD**.

Each tickmark on the **ELEVATION (1)** and **WINDAGE (2)** Turrets indicates one unit of adjustment. The value of each tickmark depends on the spacing between the front and rear mounts from center to center.

Front to Rear Mount Spacing (center to center)	Adjustment Value per Tickmark
5.4"	1/3 MOA
7.25"	1/4 MOA
9.0"	1/5 MOA
10.8"	1/6 MOA
12.6"	1/7 MOA
14.4"	1/8 MOA

Section 4: Mounting the Malcolm Short Rifle Telescope

The front and rear mounts are designed to fit the standard 60-degree base to mount externally adjusted scopes. The dovetail slots in the mounts are cut 1/2" wide. This type of base has been widely used for many externally adjusted scopes such as the Unertl and Fecker. Our clamp screw is designed to engage the crescent cut found on these bases. The supplied bases have both crescent and posa cuts.

Section 5: Sighting in the Wm. Malcolm Short Rifle Telescope

1. Check that the mounts have been correctly and securely attached to the barrel using the provided mounting blocks, and that the crosshairs in the scope are level. This can be done by loosening the **SCREW (7)** at the bottom of the

SLIDE LOCK RING (6) used in conjunction with the **FRONT MOUNT (5)**. This allows the scope tube to be rotated until the crosshairs are level. Be sure to retighten the screw after plumbing the crosshairs.

(Note: Fastening the Mounting Blocks to the rifle may require drilling and tapping by a gunsmith)

2. Familiarize yourself with all of the features of the scope and mounts, especially the **LOCK RINGS (2 & 4)** of both the **WINDAGE TURRET (3)** and **ELEVATION TURRET (1)**. Before adjustment can be made with either turret, the **LOCK RING** must be loosened by turning it **COUNTER CLOCKWISE**.
3. We recommend zeroing at just 25 yards, placing a sizeable 2'x2' or large sheet of cardboard or paper on the target board. Using a small aiming mark near the middle of the target, center the crosshairs and take a shot. If you're on the paper, you have your starting point.
4. It's best to adjust the windage first. Begin by first loosening the **LOCK RING (4)**, then adjust the **WINDAGE TURRET (3)** to move the scope tube in the direction you want to move the point of impact.

To move bullet impacts to the **RIGHT**, turn the adjustment knob **COUNTER CLOCKWISE**. To move bullet impacts to the **LEFT**, turn the windage adjustment knob **CLOCKWISE**.

Note: Like the original scopes of this design, there are no micrometer clicks. However, there are numbered graduations. Pay attention to how much you moved the adjustment knob, and how far the point of impact moved. This will make additional adjustments easier.

5. Once windage has been adjusted, retighten the **LOCK RING (4)** by turning it **CLOCKWISE finger-tight**.
6. To adjust elevation, first loosen the **LOCK RING (2)** of **ELEVATION TURRET (1)** by turning the **LOCK RING (2)** **COUNTER CLOCKWISE**.

To move point of impact **UP**, turn the adjustment knob **COUNTER CLOCKWISE**. To move point of impact **DOWN**, turn the adjustment knob **CLOCKWISE**.

7. Once elevation has been adjusted, retighten the **LOCK RING (2)** by turning it **CLOCKWISE**.
8. Move the target to 50 yards and repeat this process. Once the rifle is on paper, move the target to 100 yards and repeat again to secure a good 100 yd zero.

Note on Zeroing Certain Rifle Calibers:

The caged rear mount of the Short Wm. Malcolm Scope (circa 1890) does not provide as much elevation for low velocity big bore black powder cartridge rifles (i.e. .45-70, .50-70, .50-90) as the rear mount of the earlier styled Long Wm. Malcolm scope (circa 1870). However, it should provide ample adjustment for typical hunting ranges (100 to 200 yards) with the large .45 and .50 caliber metallic cartridge rifles, while providing adjustment for 250 to 300 yard shooting with rifles chambered for the faster and lighter bullets of cartridges like the .30-40 Krag, .30-30 Winchester or .30-06 Springfield.

We also manufacture special mounts that are compatible with our short rifle telescopes. As of this printing, we have specialty mounts for: Winchester 1885 Low and High Wall, Winchester 73/76 lever action rifles, Winchester 92/94 lever action rifles, Marlin 94/95 lever actions, Henry Big Boy and Henry Golden Boy .22 lever action rifles, and the 1874 Sharps Side Mount Set.

For more details, please contact Hi-Lux Optics customer support at (888) Hi-Lux12 (888-445-8912).

Section 6: Removing the Wm. Malcolm Short Scope Mounts

Instructions to Remove the Existing Mounts

1. Remove the eyepiece and the lock ring. The scope is sealed and the nitrogen will not escape.
2. Turn the windage and elevation turrets clockwise, until the turrets stop. Doing so will relieve some of the spring pressure of the mount on the tube.
3. Remove the rear mount slowly to reduce the likelihood of scratches on the scope body.
4. Loosen the front sliding lock ring.
5. Remove the front mount slowly from the back (Eyepiece side).

WARNING: We highly recommend that you lubricate the Malcolm scope body with Multi-Purpose Oil prior to removing the mounts. Doing so will mitigate friction from the mount sliding across the scope body.

Section 7: DiamondTuff Guarantee

Hi-Lux, Inc. warrants its products against defects arising from faulty workmanship, or materials, for the lifetime of the product. **Normal wear and tear is not covered by this limited lifetime warranty.** Any attempt to alter, dismantle or change the standard specifications of the products, will make this warranty null and void.

This warranty is made to the **original purchaser** of the goods including all international sales, and applies only to the products purchased through our authorized distributors or dealers. The international warranty is subject to approval from our authorized distributor or us directly.

Warranty obligation is limited to the repair or replacement of any product returned to **Hi-Lux, Inc.**, which is determined by the manufacturer to have defects arising from faulty workmanship, or

materials that adversely affect the satisfactory operation of the product. It should be noted that on items containing an etched glass reticle that the occasional appearance of some small particles is common and not a warrantable repair. **There is a two-year warranty from the date of purchase for the electronic components that are contained on or within the products.**

Hi-Lux, Inc. reserves the right to request proof of purchase and purchase date. To guarantee warranty service, the enclosed warranty form must be completed and returned or register online at www.hi-luxoptics.com within 90 days of purchase to establish all warranty rights between you, the original purchaser, and **Hi-Lux, Inc.**

We assume no liability for any incidental or consequential damages, or incidental expenses. Some states do not allow the exclusion or limitation of incidental or consequential damages, so the above limitations or exclusion may not apply to you. No warranties are made, or are authorized to be made, other than those expressly contained herein.

To file a claim under this warranty, please contact the Customer Service Department of **Hi-Lux, Inc.** at (310) 257-8142 to obtain a Return Authorization number (RA number). After receiving your RA number, please mark the number on the outside of the package; enclose the defective item with a brief explanation of the problem. Please be sure to include your name, address and phone number.

Failure to obtain a RA number may result in either refusal upon delivery, or lengthy delays for warranty repairs and service required for the item returned to us. All returns are to be shipped prepaid direct to **Hi-Lux, Inc.** including a check or money order in the amount of \$21 to cover postage and handling regardless of purchase date.

Attn.: Warranty & Service Dept.

Hi-Lux, Inc.

3135 Kashiwa Street

Torrance, CA 90505

Tel: (310) 257-8142, Fax: (310) 257-8096

E-Mail: service@hi-luxoptics.com

Website: www.hi-luxoptics.com

In the event of a non-warranty repair, you will receive an estimate prior to any work being done. This warranty gives you specific legal rights and you may have other rights, which vary from state to state. As defined by federal law, this is a limited warranty.

