



Count on it.

Parts Catalog

**Flex-Force Power System™ 60V
MAX**

Snowthrower

Model No. 39902—Serial No. 319000001 and Up



Ordering Replacement Parts

To order replacement parts, please supply the part number, the quantity, and the description of each part desired.

Understanding Reference Numbers

Each identified part in an illustration has a reference number. The reference number for a part also appears in the parts list, along with other information about the part.

This catalog uses two special reference number formats, one to indicate parts in a service assembly and another to indicate the quantity of a given part in an illustration.

Service Assembly Reference Numbers

Parts in service assemblies have reference numbers in the form a:b. The a represents the reference number of the entire service assembly and the b represents a sequential number unique to each part within the service assembly.

For example, a wheel assembly might be identified by reference number 6, the tire by 6:1, the valve by 6:2, and the wheel by 6:3. When you order the assembly identified by reference number 6, you receive all parts identified by reference numbers 6:1, 6:2, and 6:3. However, you may also order any part individually. Reference numbers of this type appear in illustration and in parts lists.

Reference Numbers Indicating Quantity

In an illustration, if a reference number indicates more than one part, the reference number has the form nX y. The n represents the quantity of the part, the X is the multiplication symbol, and the y represents the reference number.

For example, in an illustration, the reference number 2X 37 means that two of the parts identified by reference number 37 are indicated.

Contents

- Frame Assembly 4
- Drive Belt Assembly 6
- Chute Assembly 8
- Handle Assembly 10
- Electrical Assembly 12

Frame Assembly

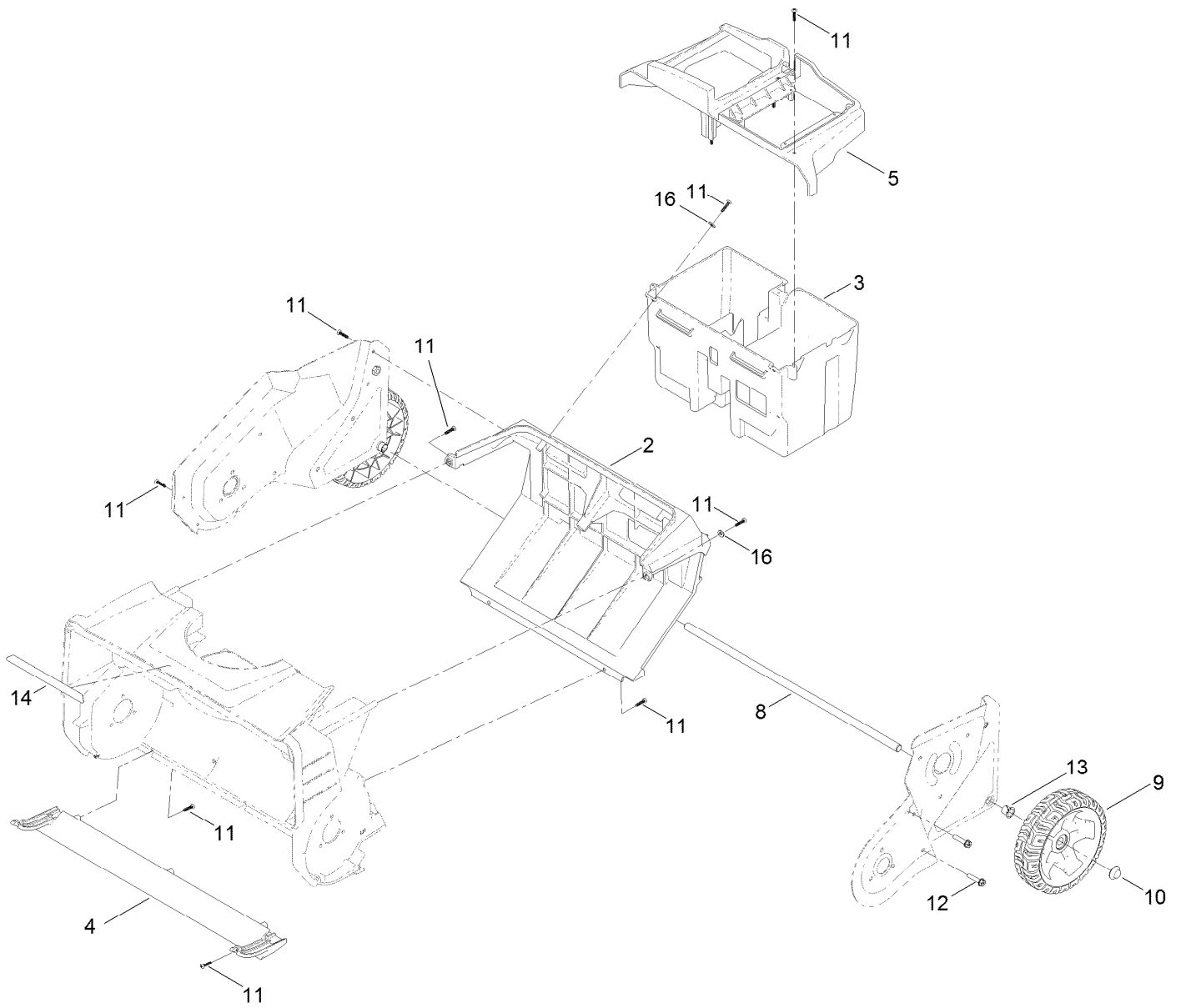

Frame Assembly (continued)

<i>Ref.</i>	<i>Part Number</i>	<i>Qty.</i>	<i>Description</i>	<i>Ref.</i>	<i>Part Number</i>	<i>Qty.</i>	<i>Description</i>
2	137-2280	1	Bulkhead	10	32112-14	2	Nut-Push
3	137-9425	1	Container-Battery	11	94-4496	25	Screw-PPH
4	137-2277	1	Scraper	12	46-8094	4	Screw-Plastic
5	137-9426	1	Skirt-Container, Battery	13	256-257	2	Bushing-Nyliner
8	137-2256	1	Axle	14	137-2333	1	Decal-Power Edge
9	137-9428	2	Wheel ASM	16	3256-77	6	Washer-Flat

Drive Belt Assembly

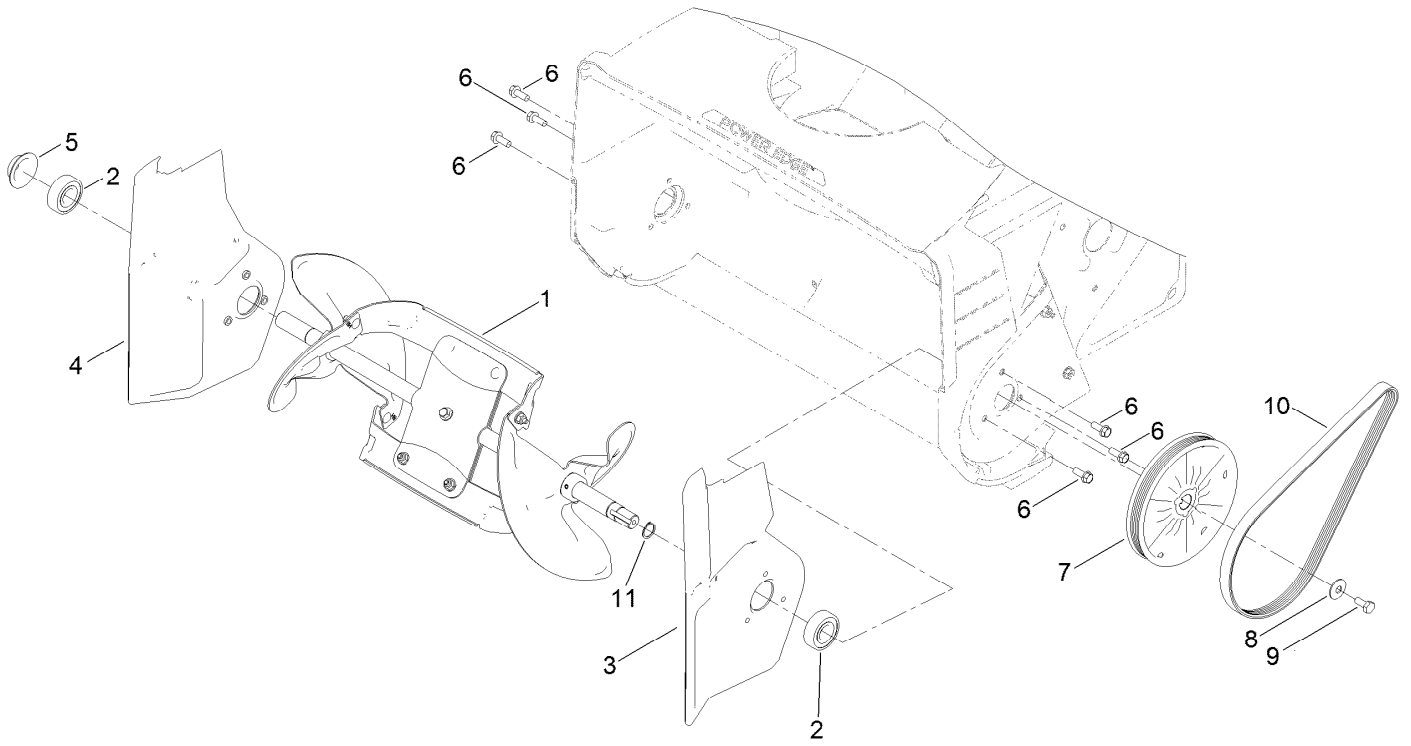

Drive Belt Assembly (continued)

<i>Ref.</i>	<i>Part Number</i>	<i>Qty.</i>	<i>Description</i>	<i>Ref.</i>	<i>Part Number</i>	<i>Qty.</i>	<i>Description</i>
1	137-9385	1	Rotor ASM	7	137-2320	1	Rotor Pulley ASM (6 Groove)
2	38-7820	2	Bearing-Ball	8	3290-456	1	Washer-Belleville
3	137-9389	1	Extension-LH	9	110-9381	1	Screw-HH
4	137-9388	1	Extension-RH	10	137-9427	1	Belt-V, Ribbed
5	139-5225	1	Cap-Sideplate, RH	11	137-9468	1	Ring-Snap, External
6	32144-85	6	Screw-HWH				

Chute Assembly

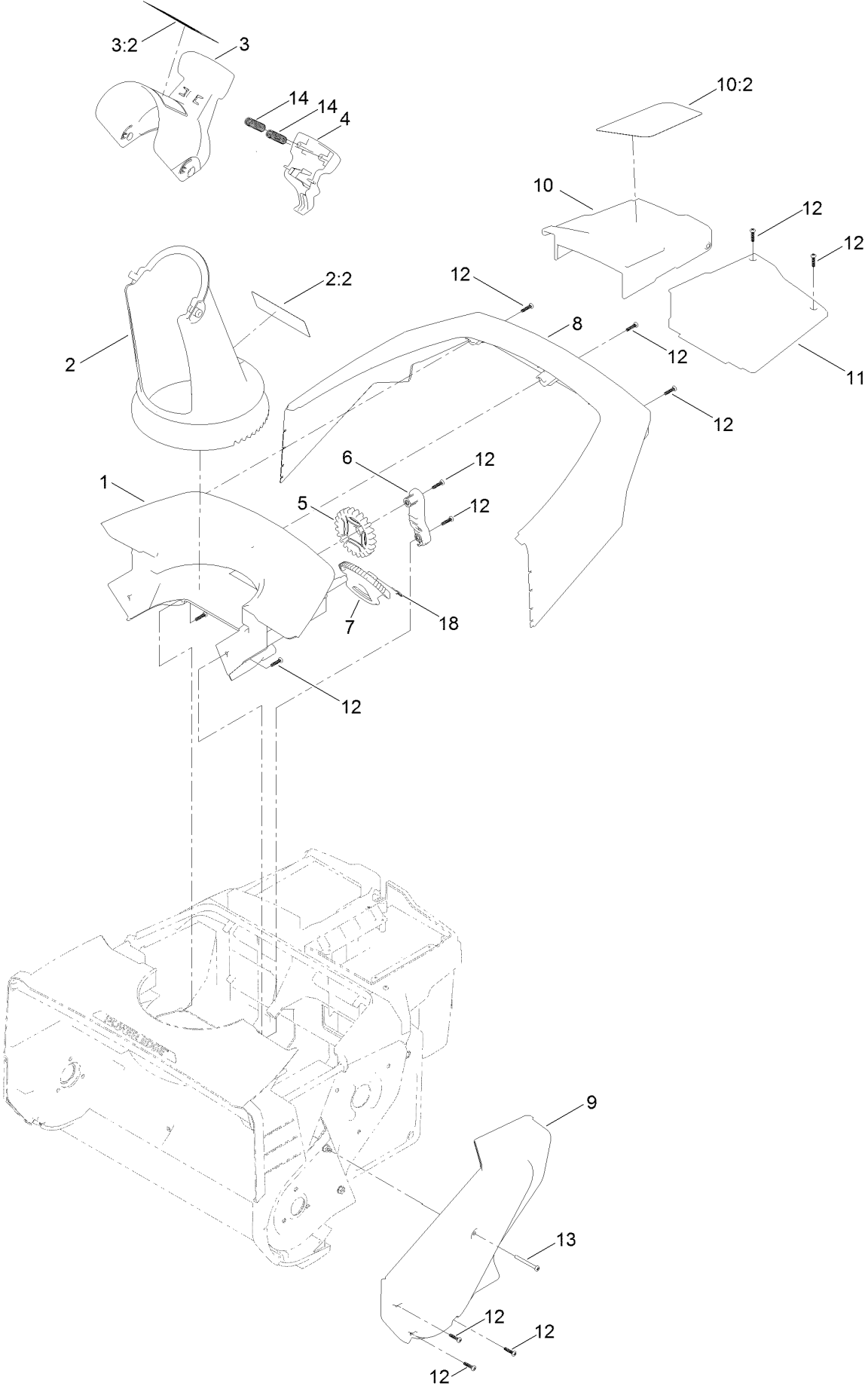

Chute Assembly (continued)

<i>Ref.</i>	<i>Part Number</i>	<i>Qty.</i>	<i>Description</i>	<i>Ref.</i>	<i>Part Number</i>	<i>Qty.</i>	<i>Description</i>
1	137-2278	1	Chute-Rear	8	137-2279	1	Shroud
2	139-5239	1	Chute	9	137-9431	1	Cover-Belt
2:2	114-9035	1	Decal-Danger, Discharge	10	139-5238	1	Cover-Battery
3	139-5240	1	Deflector-Chute	10:2	137-2332	1	Decal-Battery, 60V Snow
3:2	114-9034	1	Decal-Danger	11	137-2283	1	Cover-Controller
4	117-2314	1	Trigger-Deflector	12	94-4496	14	Screw-PPH
5	137-2271	1	Gear-Chute	13	110-3143	1	Screw-Plastic, PPH
6	137-2270	1	Bracket-Gear	14	136-7136	2	Spring-Compression
7	139-5234	1	Gear-Sector	18	139-5229	1	Clip-Handle

Handle Assembly

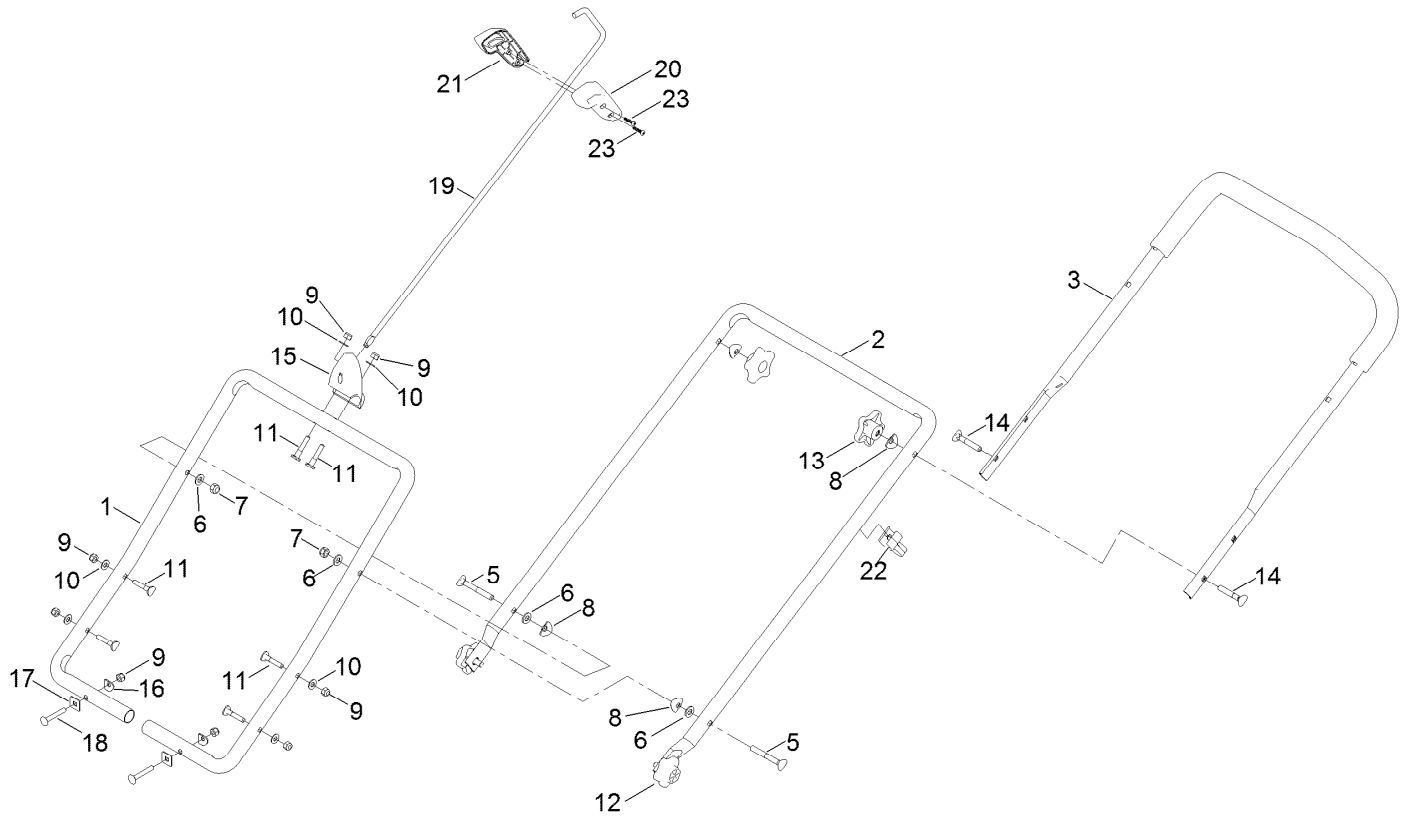

Handle Assembly (continued)

<i>Ref.</i>	<i>Part Number</i>	<i>Qty.</i>	<i>Description</i>	<i>Ref.</i>	<i>Part Number</i>	<i>Qty.</i>	<i>Description</i>
1	132-9183	1	Handle-Lower	13	139-5226	2	Knob-Locking, Handle
2	132-9184	1	Handle-Middle	14	92-2260	2	Screw-Handle
3	137-2326	1	Upper Handle ASM	15	137-9303	1	Guide-Rod, Chute
5	125-8408	2	Screw-Handle	16	3-7501	2	Washer
6	3256-70	4	Washer-Flat	17	75-9040	2	Washer-Square
7	3296-72	2	Nut-Lock, NI	18	3229-5	2	Screw-CARR
8	107-3844	4	Washer	19	137-2294	1	Rod-Control, Chute
9	3296-73	8	Nut-Lock, NI	20	137-2316	1	Grip-LH
10	3256-1	6	Washer-Flat	21	137-2317	1	Grip-RH
11	117-7737	6	Screw-Handle	22	114-7988	1	Guide-Cable
12	137-9390	2	Knob-Handle	23	94-4496	2	Screw-PPH

Electrical Assembly

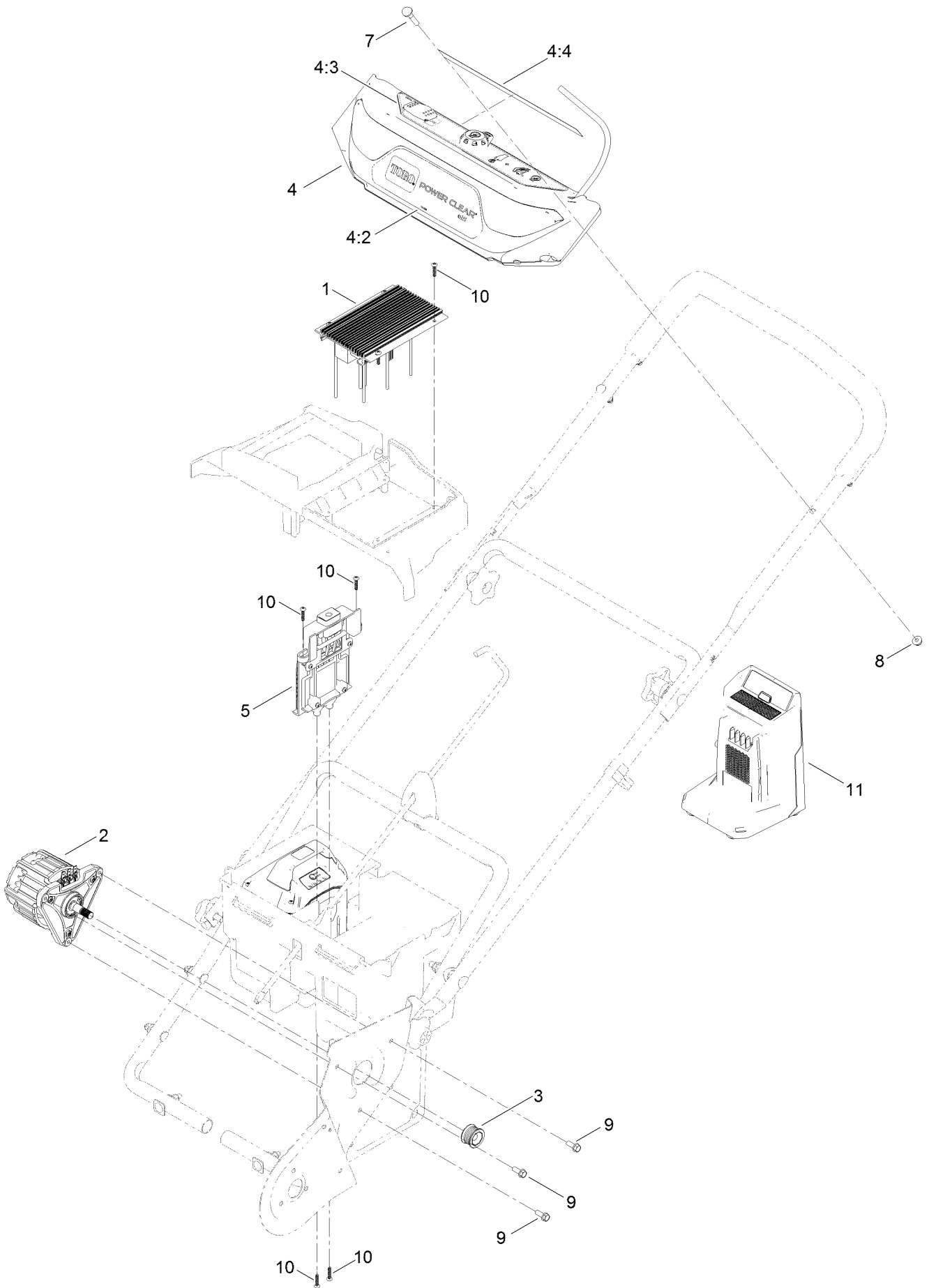

Electrical Assembly (continued)

<i>Ref.</i>	<i>Part Number</i>	<i>Qty.</i>	<i>Description</i>	<i>Ref.</i>	<i>Part Number</i>	<i>Qty.</i>	<i>Description</i>
1	137-9424	1	Motor-Driver, Snow (60V)	5	137-9404	1	Battery Track ASM
2	137-9423	1	Motor-60V Snowblower	6	137-9447	2	60V Battery, 3P 6.0Ah ●
3	137-9433	1	Pulley-Motor	7	117-7737	4	Screw-Handle
4	137-2347	1	Dash Panel ASM W/Decals	8	104-7201	4	Nut-HF
4:2	137-2259	1	Decal-Power Clear	9	32144-85	3	Screw-HWH
4:3	137-2258	1	Decal-Operation	10	94-4496	8	Screw-PPH
4:4	137-2257	1	Decal-Caution	11	137-9439	1	Charger-60V (2A)

● Not illustrated

Notes:

Notes:



Count on it.