



Count on it.

Parts Catalog

**Power Clear® 518 ZR
Snowthrower**

Model No. 38472—Serial No. 315000001 and Up



Ordering Replacement Parts

To order replacement parts, please supply the part number, the quantity, and the description of each part desired.

Understanding Reference Numbers

Each identified part in an illustration has a reference number. The reference number for a part also appears in the parts list, along with other information about the part.

This catalog uses two special reference number formats, one to indicate parts in a service assembly and another to indicate the quantity of a given part in an illustration.

Service Assembly Reference Numbers

Parts in service assemblies have reference numbers in the form a:b. The a represents the reference number of the entire service assembly and the b represents a sequential number unique to each part within the service assembly.

For example, a wheel assembly might be identified by reference number 6, the tire by 6:1, the valve by 6:2, and the wheel by 6:3. When you order the assembly identified by reference number 6, you receive all parts identified by reference numbers 6:1, 6:2, and 6:3. However, you may also order any part individually. Reference numbers of this type appear in illustration and in parts lists.

Reference Numbers Indicating Quantity

In an illustration, if a reference number indicates more than one part, the reference number has the form nX y. The n represents the quantity of the part, the X is the multiplication symbol, and the y represents the reference number.

For example, in an illustration, the reference number 2X 37 means that two of the parts identified by reference number 37 are indicated.

List of Abbreviations

AR: as required

ASM: assembly

BBC: blade brake control

BHTF: button head thread forming

CARR: carriage

CCW: counter clockwise

CW: clockwise

DEG: degrees

DPA: Dual Point Adjustment

ECM: electronic control module

EXT: external

FH: flat head

GA: gauge

HD: heavy-duty

HF: hex flange

HH: hex head

HHF: hex head flange

HHFTF: hex head flange thread forming

HJ: hex jam

HLH: hex lag head

HOC: height-of-cut

HSBH: hex socket button head

HSFH: hex socket flat head

HSH: hex socket head

HWH: hex washer head

HWHTF: hex washer head thread forming

HYD: hydraulic

LH: left hand

LP: Liquefied Petroleum Gas

LPG: Liquefied Petroleum Gas

NI: nylon insert

NPTF: national pipe thread fine

PFH: phillips flat head

PPH: phillips pan head

PPHTF: phillips pan head thread forming

PRH: phillips round head

PTH: phillips truss head

PTO: power-take-off

RH: right hand

ROPS: roll-over protection system

RRB: rear roller brush

SFH: slotted fillister head

SHH: slotted hex head

SHWH: slotted hex washer head

SPH: slotted pan head

SQH: square head

SRH: slotted round head

STD: standard

TAP: self tapping

TTH: torx truss head

Contents

Main Frame and Wheel Assembly	4
Auger Housing Assembly	6
Rotor Drive Assembly	8
Belt and Drive Assembly	10
Engine Assembly	12
Engine Assembly No. 1	14
Engine Assembly No. 2	16
Engine Assembly No. 3	18
Shroud Assembly	20
Handle Assembly	22
Deflector Chute Control Assembly	24
Attachments and Accessories	26

Main Frame and Wheel Assembly

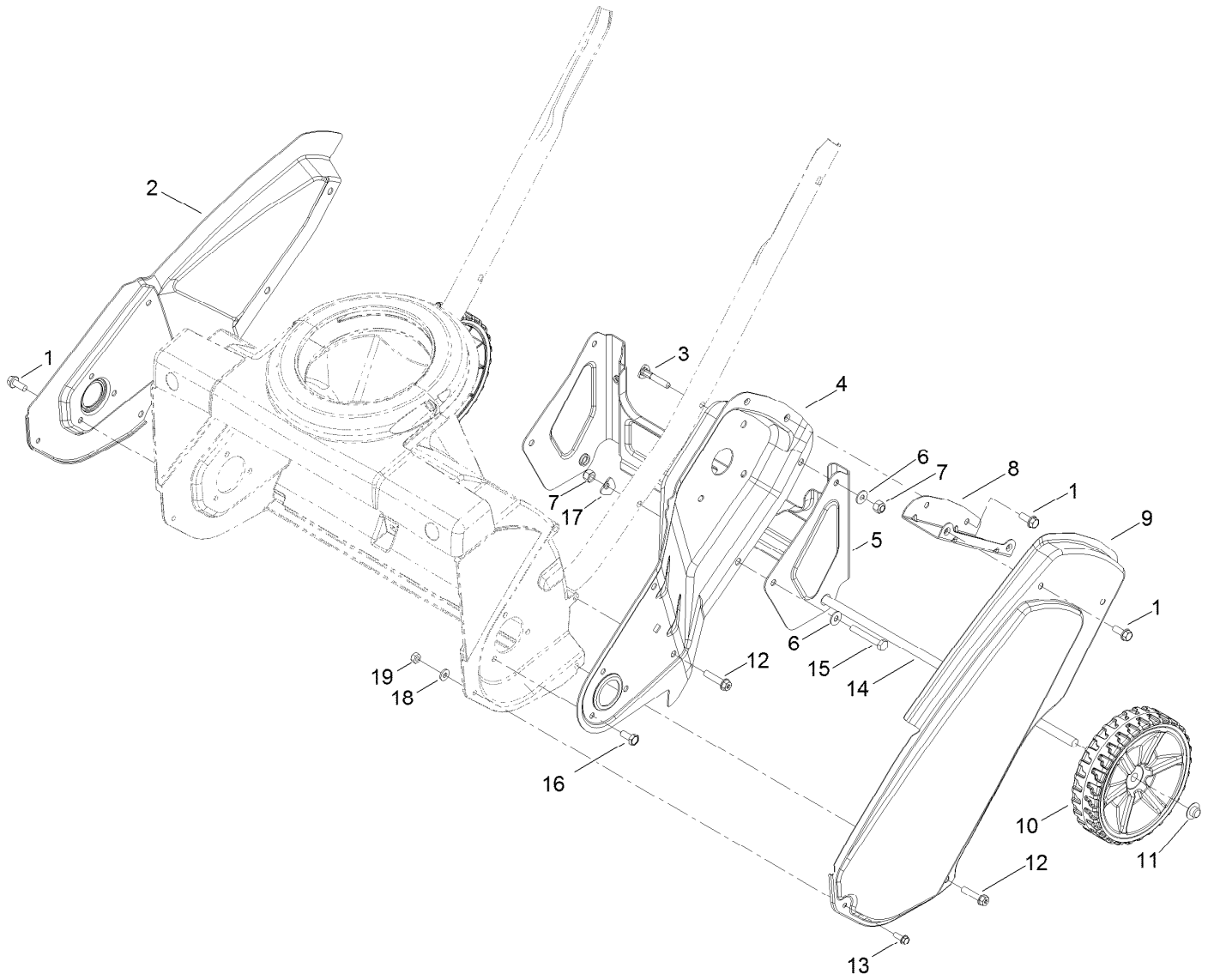

Main Frame and Wheel Assembly (continued)

<i>Ref.</i>	<i>Part Number</i>	<i>Qty.</i>	<i>Description</i>	<i>Ref.</i>	<i>Part Number</i>	<i>Qty.</i>	<i>Description</i>
1	32144-85	7	Screw-HWH	11	3290-320	2	Retainer-Push On
2	117-7704-03	1	Sideplate-RH	12	46-8094	6	Screw-Plastite
3	117-7737	2	Screw-Handle	13	32105-23	2	Screw
4	117-2349-03	1	Sideplate-LH	14	117-2339	1	Axle
5	117-7702-03	1	Bracket-Wheel	15	321-53	2	Screw-HH
6	3256-1	4	Washer-Flat	16	114-9291	3	Screw-HH, Taptite
7	3296-73	4	Nut-Lock, NI	17	3-7501	2	Washer
8	117-2334-03	1	Bracket-Cover, Belt	18	3256-14	2	Washer-Flat
9	117-7703-03	1	Cover-Belt	19	3296-2	2	Nut-Lock, NI
10	117-2306	2	Wheel ASM				

Auger Housing Assembly

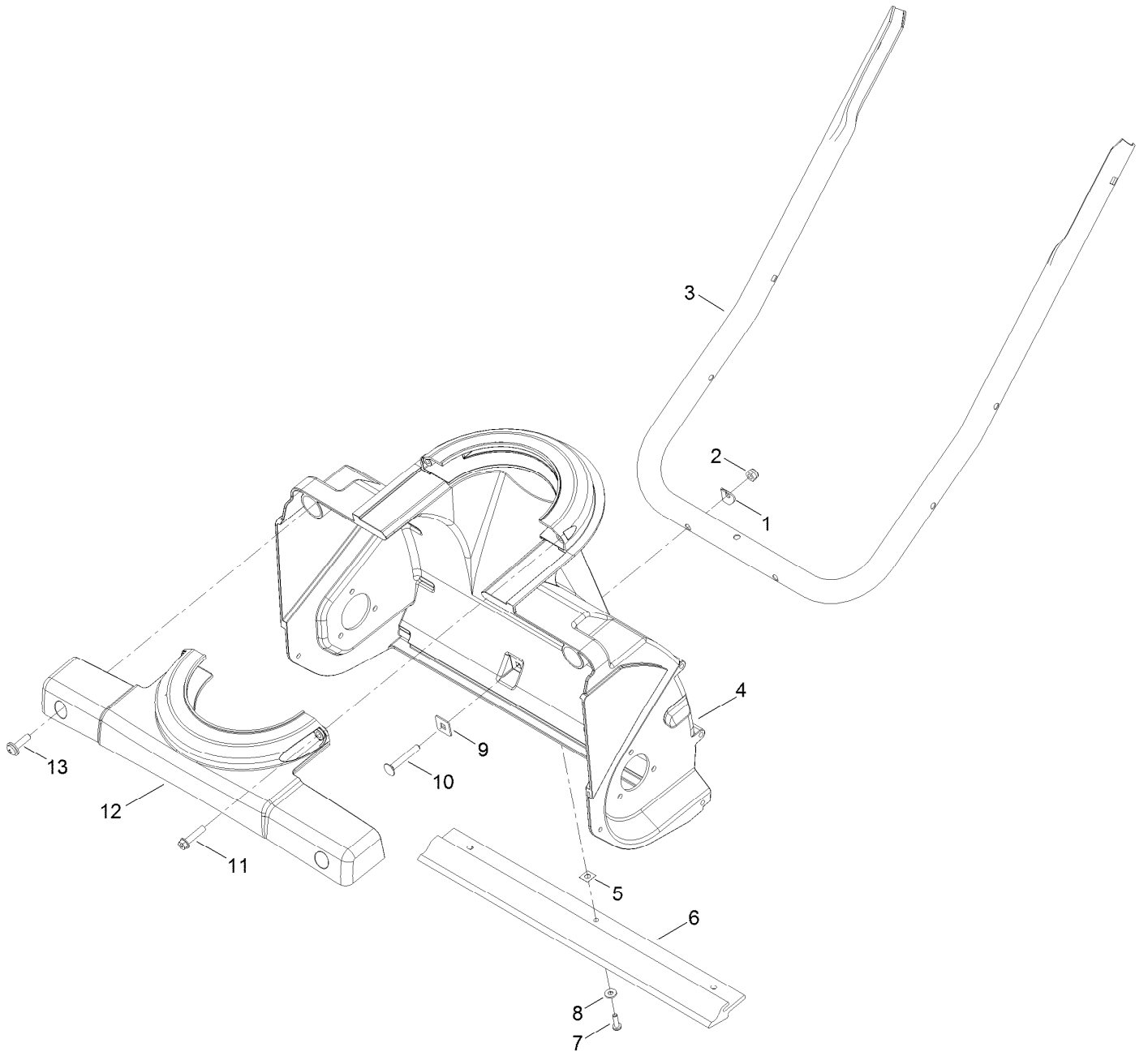

Auger Housing Assembly (continued)

<i>Ref.</i>	<i>Part Number</i>	<i>Qty.</i>	<i>Description</i>	<i>Ref.</i>	<i>Part Number</i>	<i>Qty.</i>	<i>Description</i>
1	3-7501	2	Washer	8	3256-14	3	Washer-Flat
2	3296-73	2	Nut-Lock, NI	9	75-9040	2	Washer-Square
3	117-2348-03	1	Handle-Lower	10	3229-5	2	Screw-CARR
4	117-2331	1	Housing-Lower	11	46-8094	2	Screw-Plastite
5	32115-19	3	Nut-Clip, U	12	117-2332	1	Retainer-Chute
6	117-7717	1	Scraper	13	110-9361	2	Screw-PPH, Sems
7	32144-34	3	Screw-HWHTF				

Rotor Drive Assembly

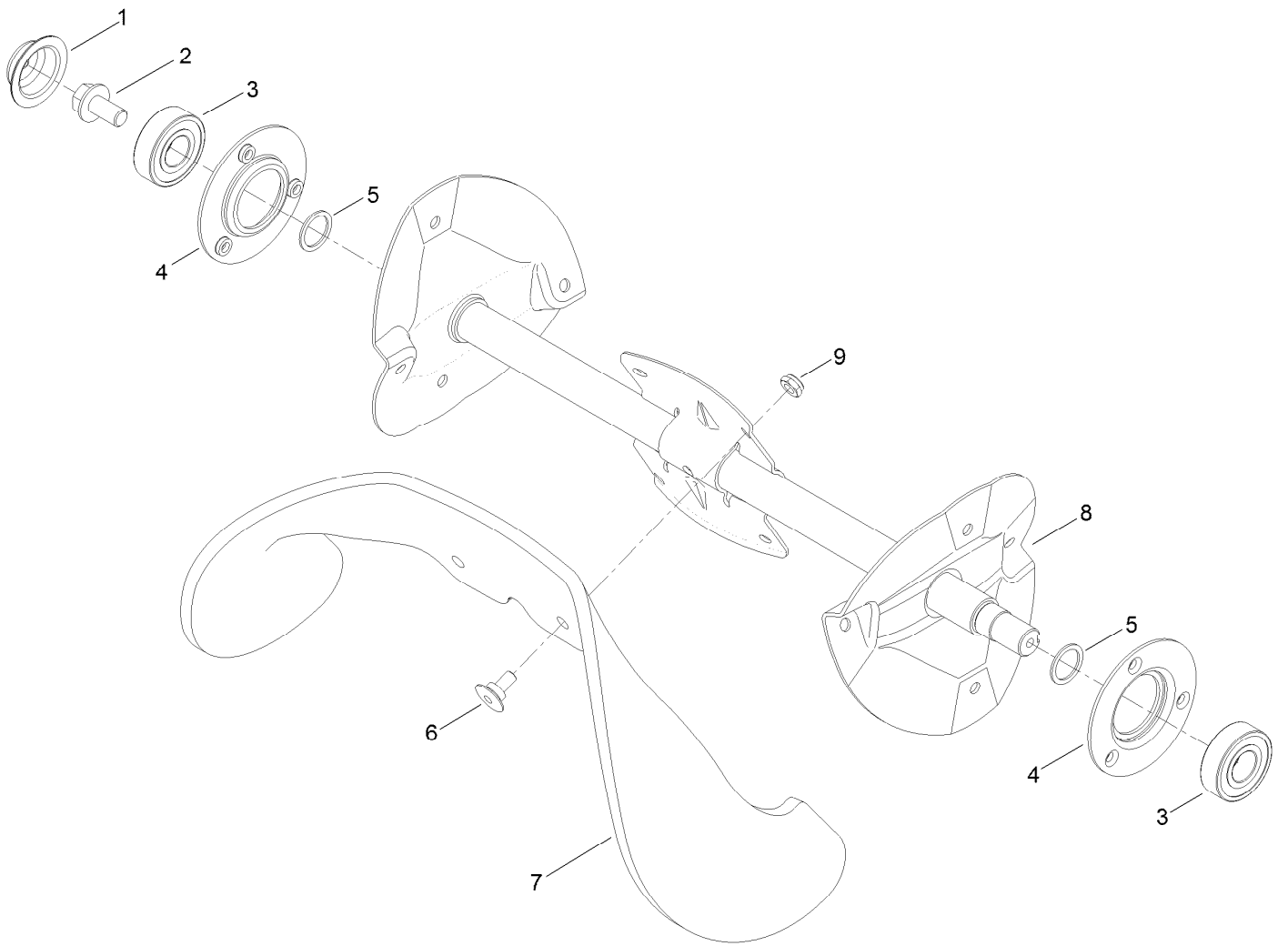

Rotor Drive Assembly (continued)

<i>Ref.</i>	<i>Part Number</i>	<i>Qty.</i>	<i>Description</i>	<i>Ref.</i>	<i>Part Number</i>	<i>Qty.</i>	<i>Description</i>
1	117-7720	1	Cap-Sideplate, RH	6	84-1970	12	Screw
2	110-9380	1	Screw-HWH	7	117-7700	2	Blade-Rotor
3	100-1048	2	Bearing-Ball	8	117-2315-03	1	Rotor ASM
4	112-8105	2	Flange-Bearing	9	3296-56	12	Nut-Lock, NI
5	52-7280	2	Washer-Thrust				

Belt and Drive Assembly

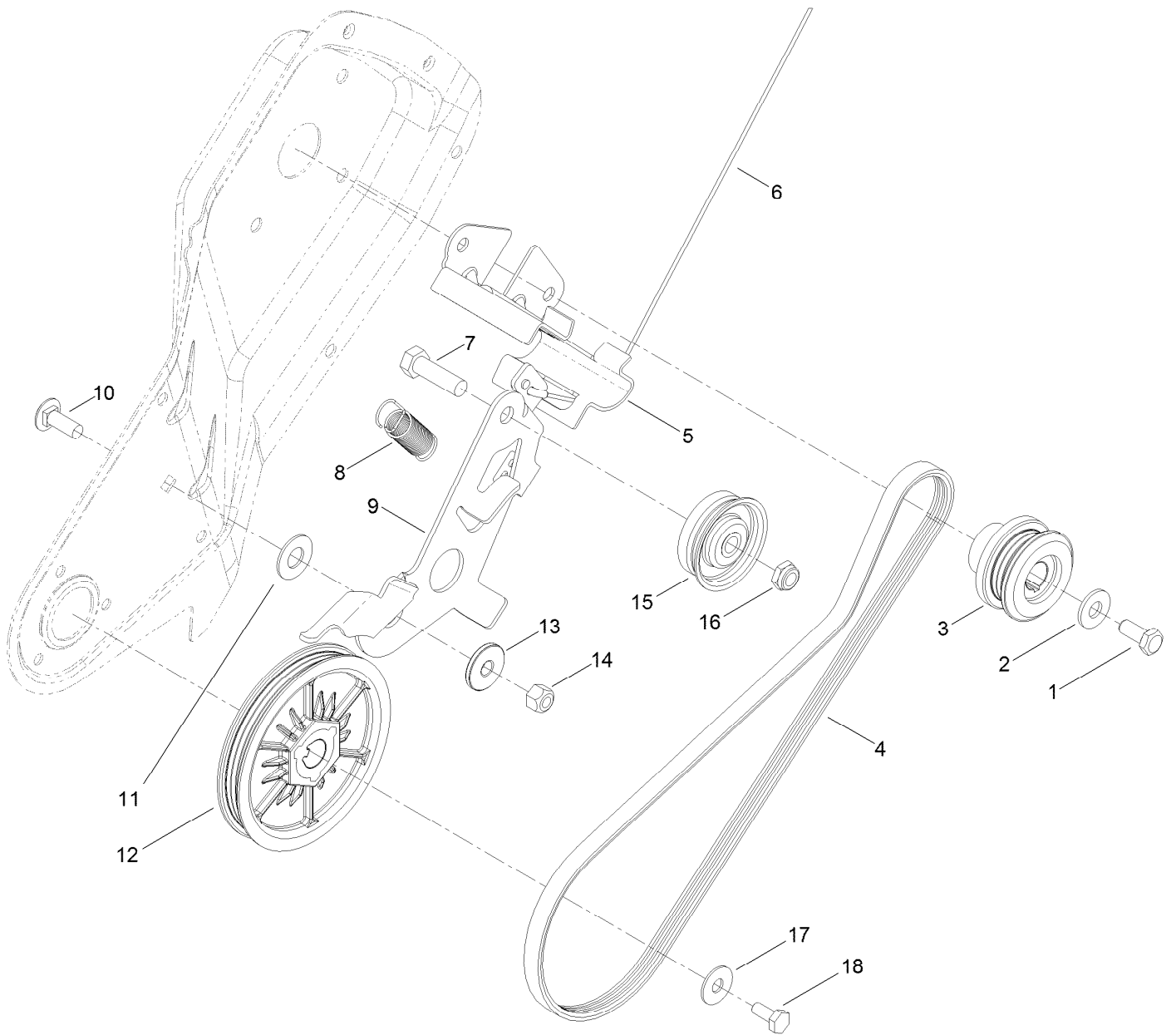

Belt and Drive Assembly (continued)

<i>Ref.</i>	<i>Part Number</i>	<i>Qty.</i>	<i>Description</i>	<i>Ref.</i>	<i>Part Number</i>	<i>Qty.</i>	<i>Description</i>
1	3235-6	1	Screw-HH	10	3230-10	1	Screw-CARR
2	3256-71	1	Washer-Flat	11	25-5640	1	Washer
3	117-7734	1	Pulley-Engine	12	117-7732	1	Rotor Pulley ASM
4	117-7733	1	Belt-V, Ribbed	13	117-7711	1	Bushing-Idler
5	119-2907	1	Guide-Belt	14	3296-29	1	Nut-Lock, NI
6	117-7721	1	Cable-Clutch	15	117-9105	1	Pulley-Idler
7	323-44	1	Screw-HH	16	3296-59	1	Nut-Lock, NI
8	117-7715	1	Spring-Brake	17	3290-456	1	Washer-Belleville
9	117-7735	1	Arm-Idler	18	110-9381	1	Screw-HH

Engine Assembly

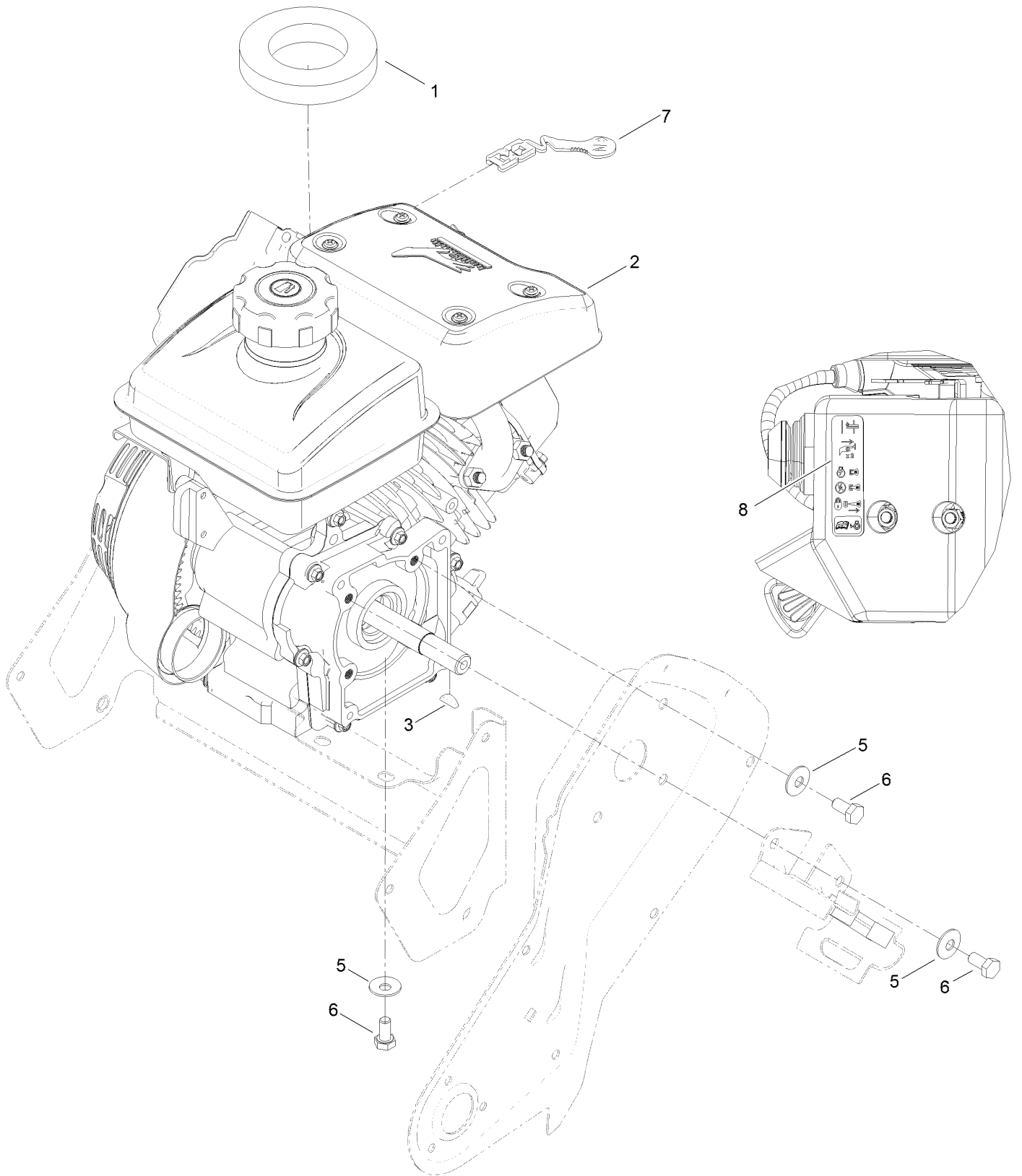

Engine Assembly (continued)

<i>Ref.</i>	<i>Part Number</i>	<i>Qty.</i>	<i>Description</i>	<i>Ref.</i>	<i>Part Number</i>	<i>Qty.</i>	<i>Description</i>
1	117-7723	1	Seal-Tank	6	33114-016	6	Screw-HH
2	121-4230	1	Engine-Lc156Fs	7	117-7727	1	Lever-Choke
3	3257-3	1	Key-Woodruff	8	120-0149	1	Decal-Controls, Engine
5	3290-456	6	Washer-Belleville				

Engine Assembly No. 1

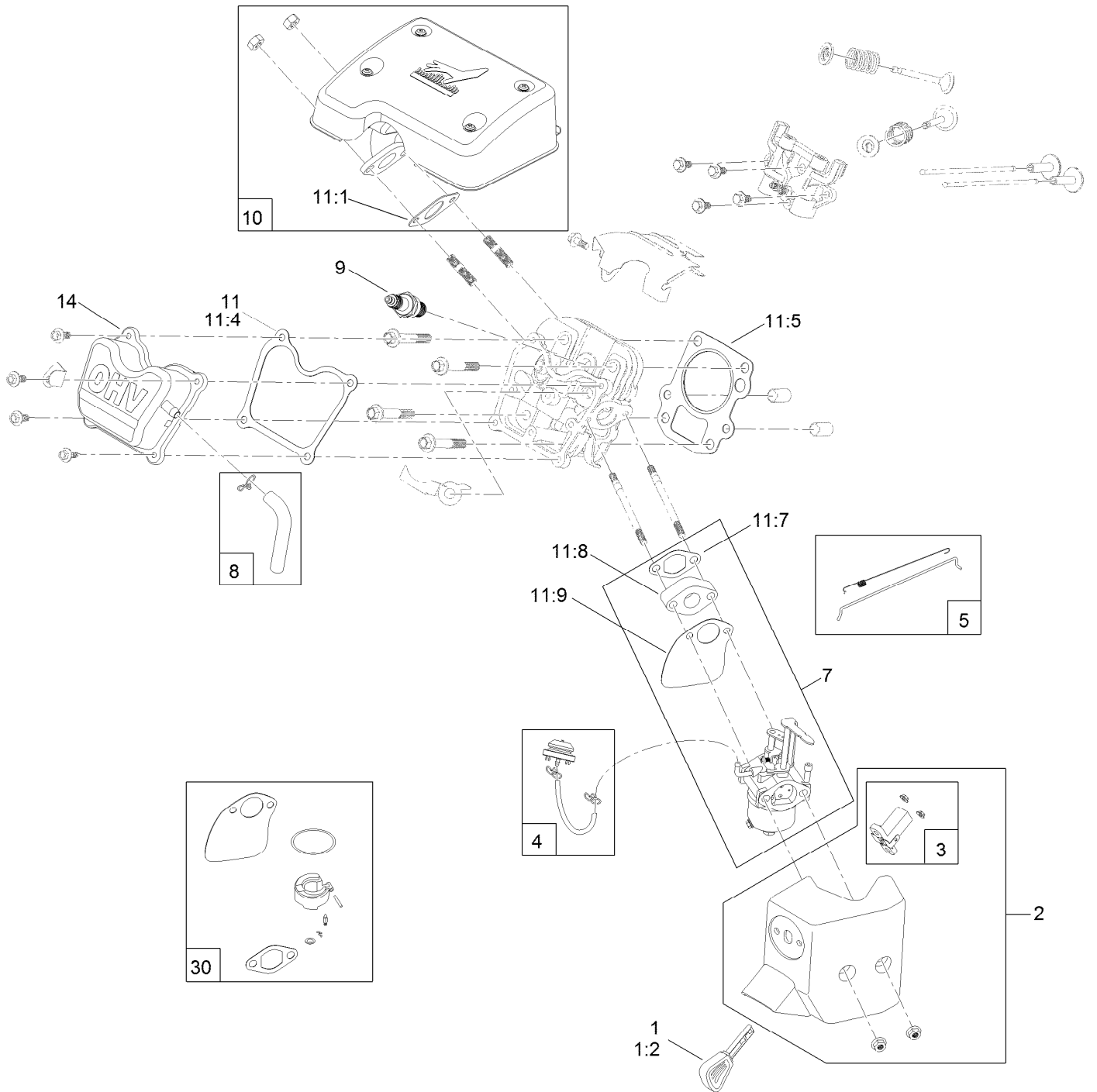

Engine Assembly No. 1 (continued)

<i>Ref.</i>	<i>Part Number</i>	<i>Qty.</i>	<i>Description</i>	<i>Ref.</i>	<i>Part Number</i>	<i>Qty.</i>	<i>Description</i>
1	119-1929	1	Key And Lanyard Kit	11:2		1	Seal-Oil ■●
1:2	117-7728	2	Key	11:3		1	Seal-Oil ■●
2	119-1982	1	Heater Box Kit	11:4	121-0110	1	Gasket-Cover, Valve
3	119-1932	1	Switch Kit	11:5		1	Gasket-Head, Cylinder ■
4	119-1981	1	Primer Bulb Kit	11:6		1	Gasket-Cover, Crankcase ■ ●
5	127-9074	1	Governor Kit	11:7		1	Gasket-Insulator ■
7	127-9053	1	Complete Carb Service Kit	11:8		1	Insulator-Carburetor ■
8	119-1921	1	Breather Tube Kit	11:9		1	Gasket-Carburetor ■
9	119-1961	1	Spark Plug	14	121-0466	1	Valve Cover ASM
10	119-1938	1	Muffler Kit	30	119-1988	1	Carb Float And Needle Kit
11	127-9073	1	Gasket, Seal And O-Ring Kit				
11:1		1	Gasket-Exhaust ■				

● Not illustrated

■ Not serviced separately

Engine Assembly No. 2

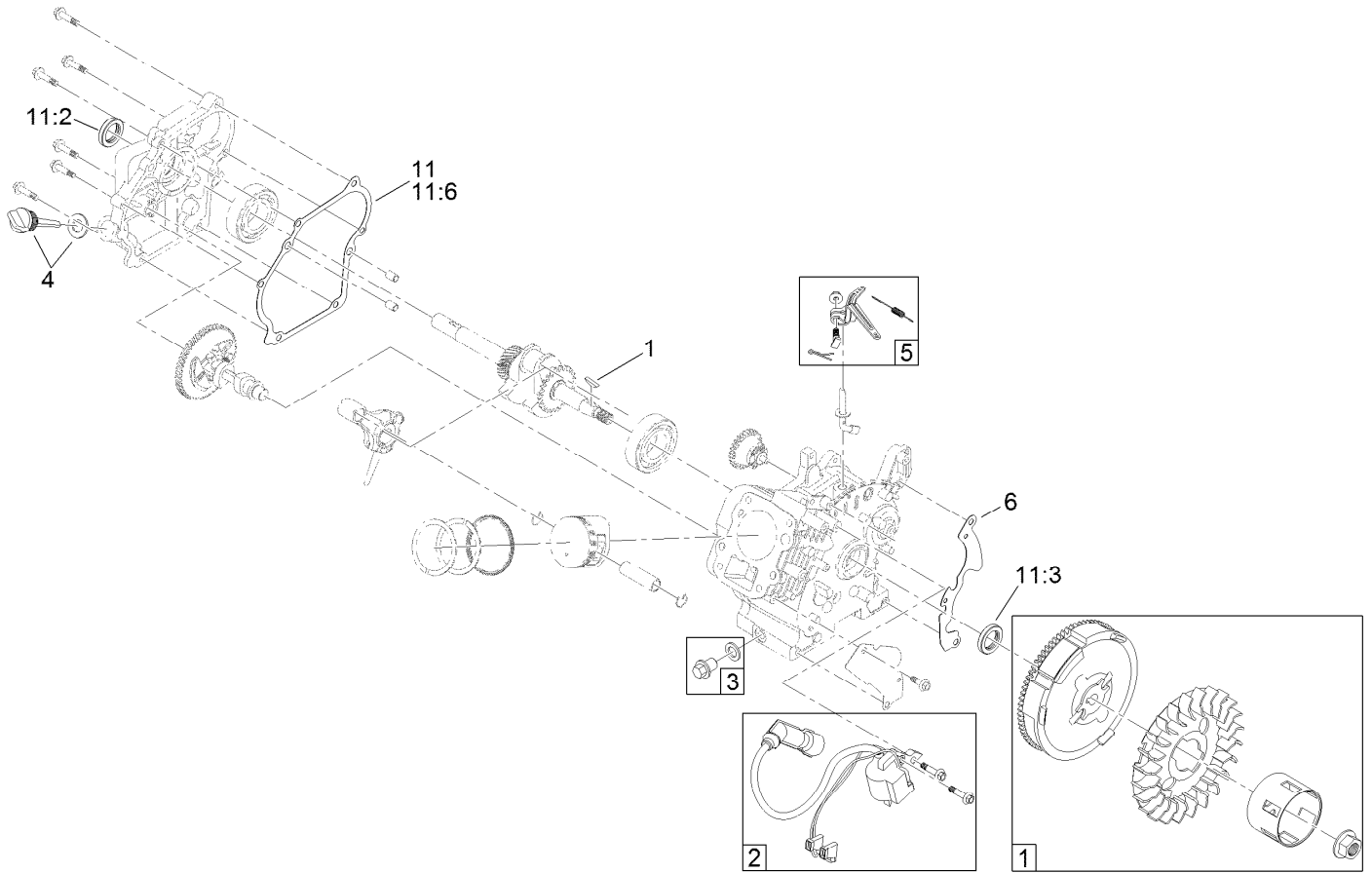

Engine Assembly No. 2 (continued)

<i>Ref.</i>	<i>Part Number</i>	<i>Qty.</i>	<i>Description</i>	<i>Ref.</i>	<i>Part Number</i>	<i>Qty.</i>	<i>Description</i>
1	119-1962	1	Flywheel And Fan Kit	11:2		1	Seal-Oil ■
2	119-1960	1	Ignition Kit	11:3		1	Seal-Oil ■
3	119-1923	1	Drain Plug Kit	11:4	121-0110	1	Gasket-Cover, Valve ●
4	119-1922	1	Dipstick And O-Ring Kit	11:5		1	Gasket-Head, Cylinder ■●
5	127-9074	1	Governor Kit	11:6		1	Gasket-Cover, Crankcase ■
6	119-1927	1	Blower Shroud Kit	11:7		1	Gasket-Insulator ■●
11	127-9073	1	Gasket, Seal And O-Ring Kit	11:8		1	Insulator-Carburetor ■●
11:1		1	Gasket-Exhaust ■●	11:9		1	Gasket-Carburetor ■●

● Not illustrated

■ Not serviced separately

Engine Assembly No. 3

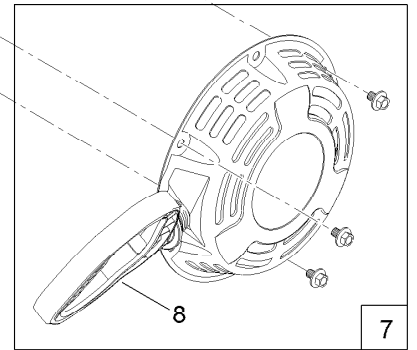
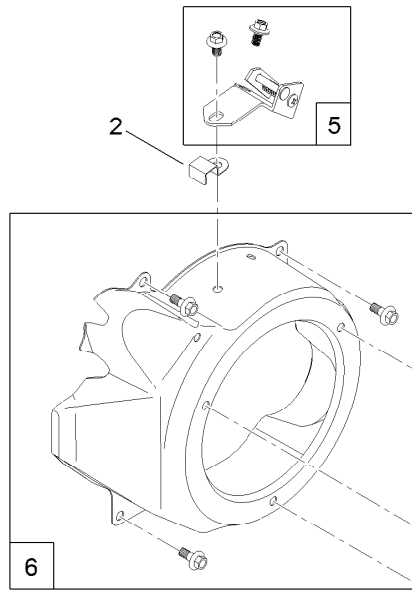
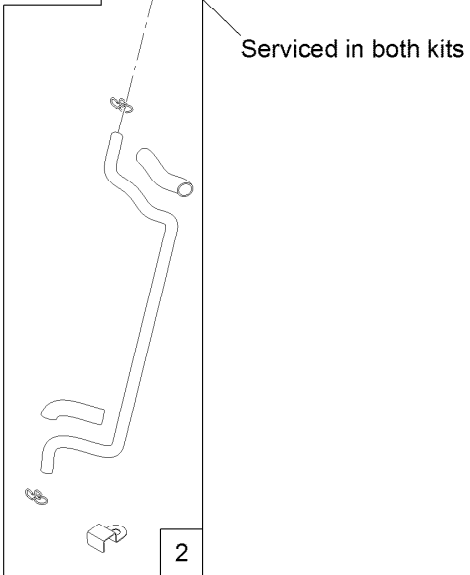
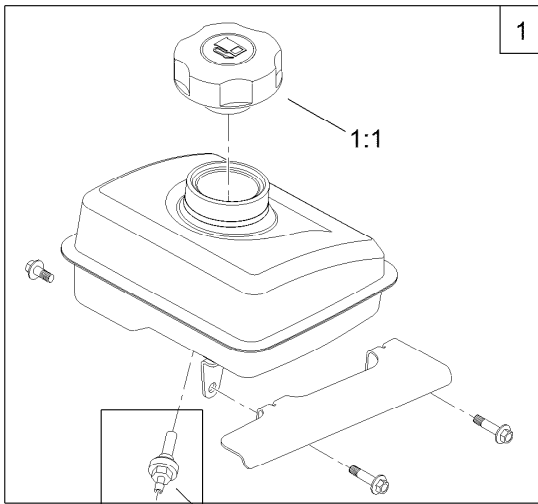

Engine Assembly No. 3 (continued)

<i>Ref.</i>	<i>Part Number</i>	<i>Qty.</i>	<i>Description</i>
1	127-9075	1	Fuel Tank And Cap Kit
1:1	121-0257	1	Cap-Fuel
2	127-9072	1	Fuel Line Kit
5	127-9074	1	Governor Kit

<i>Ref.</i>	<i>Part Number</i>	<i>Qty.</i>	<i>Description</i>
6	119-1927	1	Blower Shroud Kit
7	119-1925	1	Recoil ASM Kit
8	119-1924	1	Mitten Grip Kit

Shroud Assembly

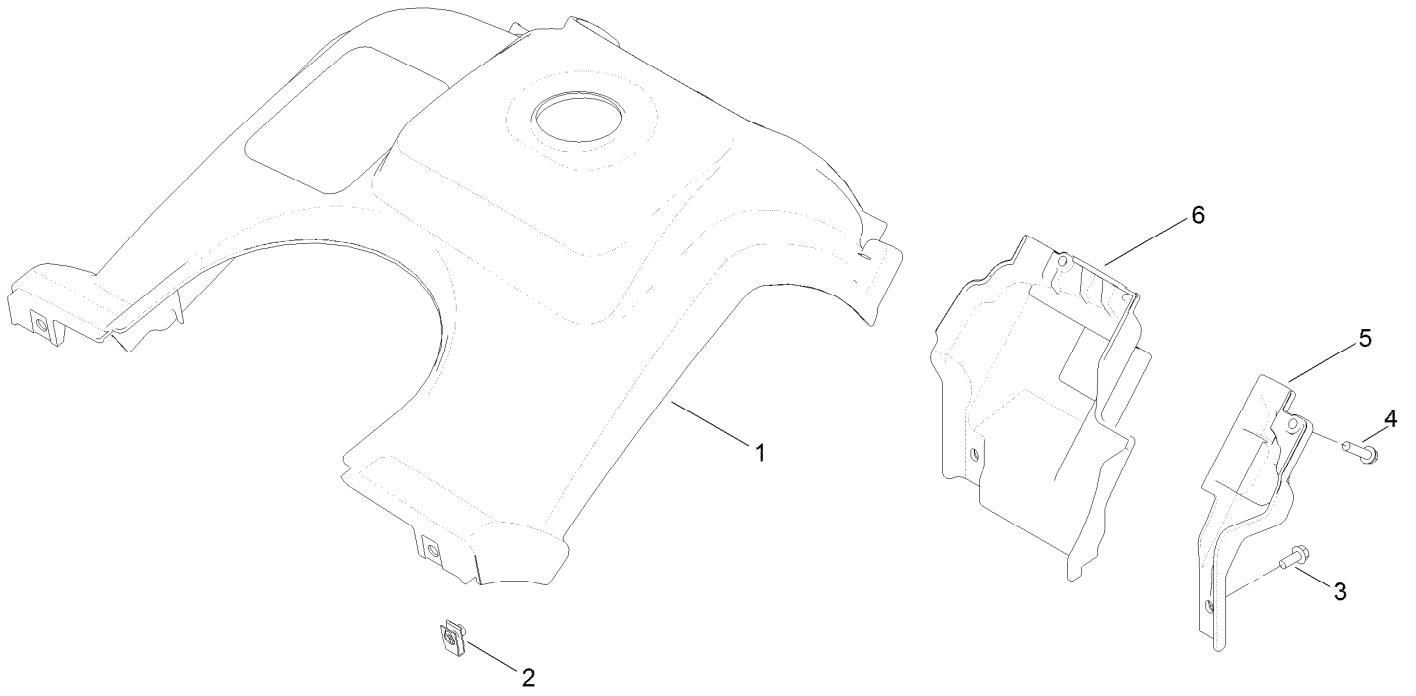

Shroud Assembly (continued)

<i>Ref.</i>	<i>Part Number</i>	<i>Qty.</i>	<i>Description</i>	<i>Ref.</i>	<i>Part Number</i>	<i>Qty.</i>	<i>Description</i>
1	127-5968	1	Shroud ASM	4	46-8094	2	Screw-Plastite
2	107069	2	Clip	5	117-7719	1	Shroud-Lower, LH
3	32144-85	2	Screw-HWH	6	117-7729	1	Shroud-Lower, RH

Handle Assembly

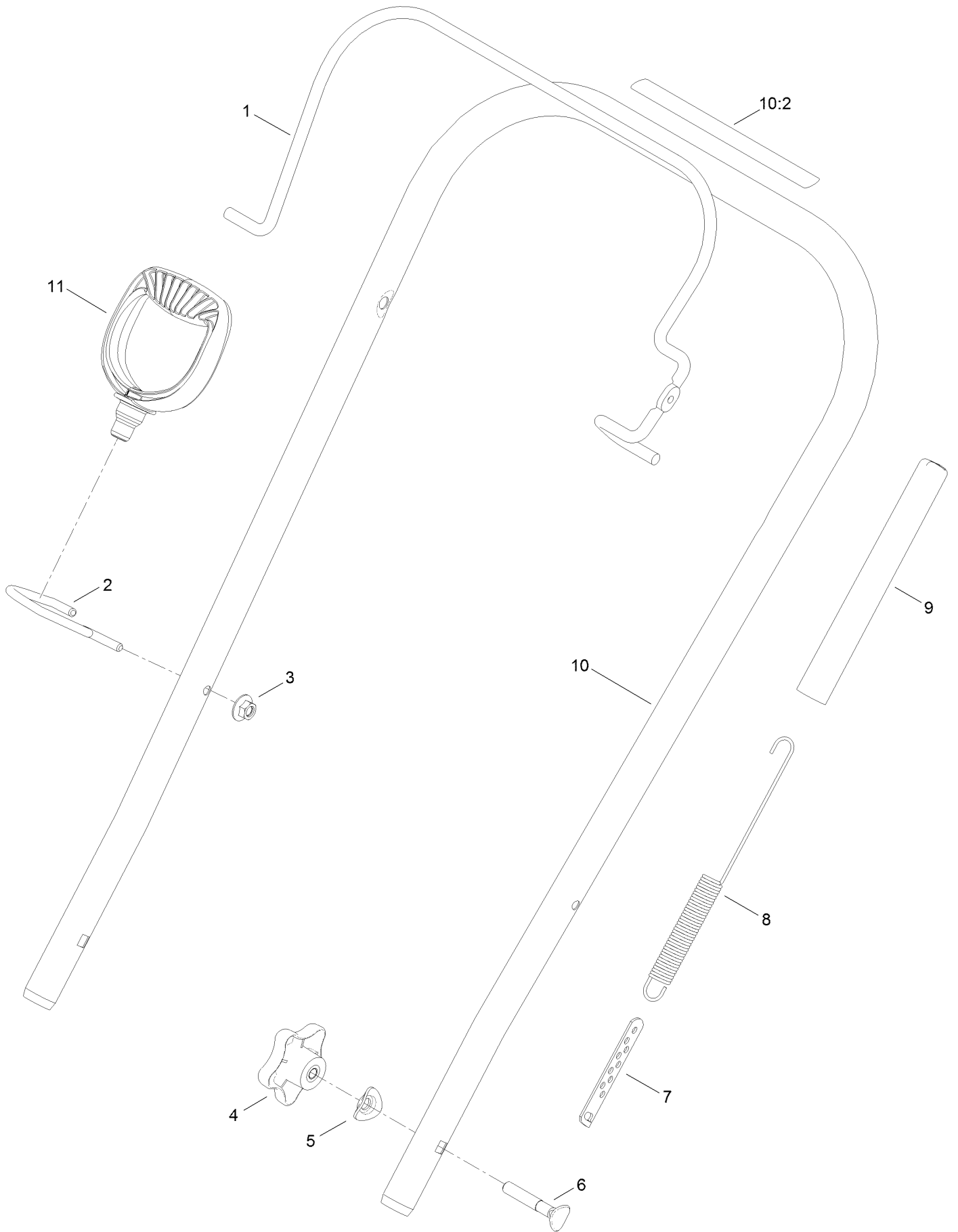

Handle Assembly (continued)

<i>Ref.</i>	<i>Part Number</i>	<i>Qty.</i>	<i>Description</i>	<i>Ref.</i>	<i>Part Number</i>	<i>Qty.</i>	<i>Description</i>
1	117-7718-03	1	Bail-Clutch	7	71-5330	1	Adjuster-Cable, Clutch
2	120-9804	1	Guide-Rope	8	119-2913	1	Spring-Clutch
3	114-3778	1	Nut-Lock, NI	9	114-3796	1	Cover-Spring
4	106-4161	2	Knob-Handle	10	117-7743	1	Upper Handle ASM
5	107-3844	2	Washer	10:2	117-7713	1	Decal-Safety
6	92-2260	2	Screw-Handle	11	117-9104	1	Handle-Recoil

Deflector Chute Control Assembly

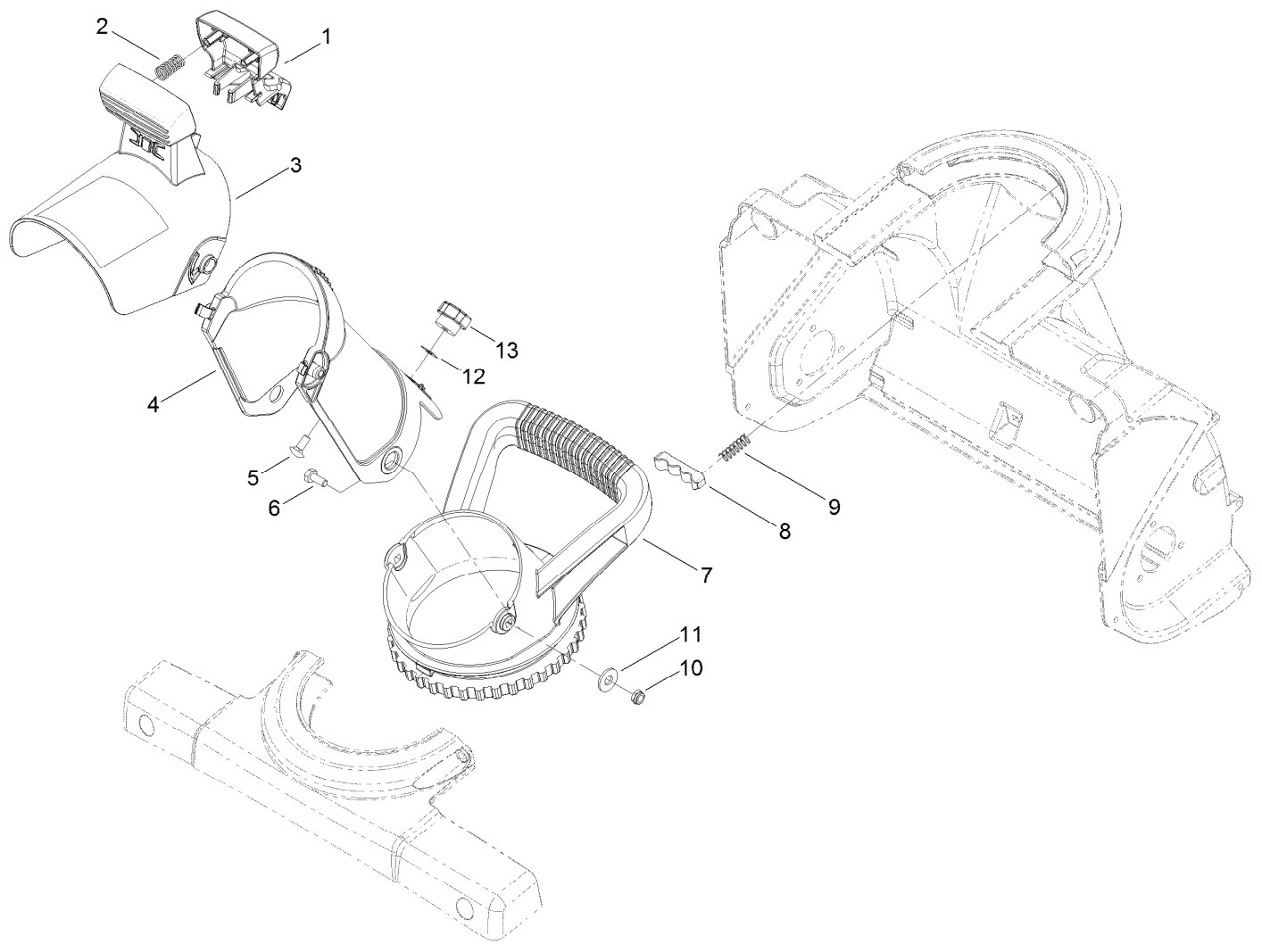

Deflector Chute Control Assembly (continued)

<i>Ref.</i>	<i>Part Number</i>	<i>Qty.</i>	<i>Description</i>	<i>Ref.</i>	<i>Part Number</i>	<i>Qty.</i>	<i>Description</i>
1	117-2314	1	Trigger-Deflector	8	75-9160	1	Detent-Chute
2	110-9360	2	Spring-Compression	9	75-9170	2	Spring-Compression
3	117-7742	1	Chute Deflector ASM	10	3296-56	2	Nut-Lock, NI
4	117-2312	1	Chute-Discharge	11	3256-81	2	Washer-Flat
5	3229-11	1	Screw-CARR	12	32115-15	1	Pushnut-Retainer, Bolt
6	321-3	2	Screw-HH	13	233-67	1	Knob-Chute
7	117-2345	1	Handle-Chute				

Attachments and Accessories

For 38472 Power Clear 518 ZR Snowthrower

Product Name	Model/Part
High-Altitude Kit.....	121-4239
Paddle Replacement Kit.....	38266
Case of 24 12-Ounce Bottles 5W30 Winter Oil.....	38907
Toro Snow Oil 0W30 Synthetic 20-Ounce Bottle.....	38913

Notes:



Count on it.