

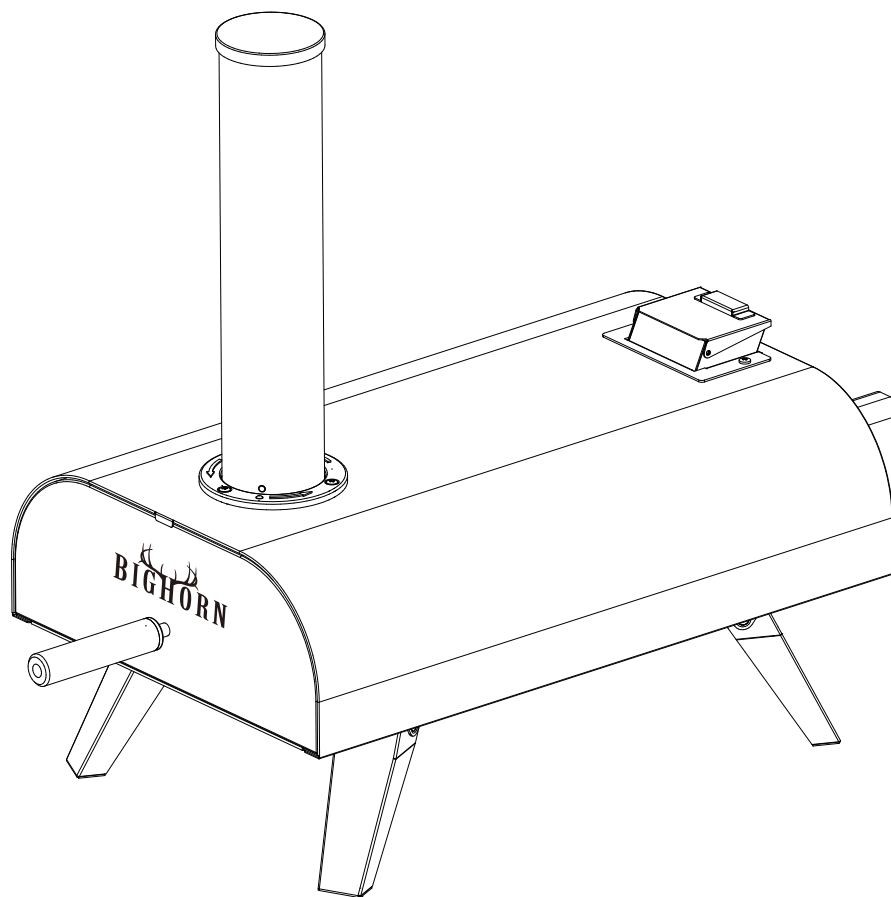

Pellet Pizza Oven

Model# SRPG18003



ATTACH YOUR RECEIPT HERE

Serial Number _____ Purchase Date _____



Questions, problems, missing parts? Before returning to your retailer, call our customer service department at 1-888-909-3888, 7:30 AM – 4:30 PM PST, Monday - Friday, or e-mail to cs@shinerichgroup.com.

Before you start

⚠ These instructions are for your safety. Please read through them thoroughly before use and retain them for future reference.

- Please dispose all plastic bags carefully and keep it away from children.
- Check the part and make sure you have all of the parts listed. If not, contact your local store who will be able to help you.
- Take a few moments to familiarize yourself with the contents & before starting check all holes are clear of any paint residue.
- When you are ready to start, make sure that you have plenty of space and a clean dry area for assembly.
- **Important** - Whilst every care is taken in the manufacture of this product, care must be taken during assembly in case sharp edges are present.

Food cooking information

- Please read and follow this advice when cooking on your grill.
- **ALWAYS** wash your hands before or after handling uncooked meat and before eating.
- **ALWAYS** keep raw meat away from cooked meat and other foods.
- Before cooking ensure pizza oven grill surfaces and tools are clean and free of old food residues.
- **DO NOT** use the same utensils to handle cooked and uncooked foods.
- Ensure all meat is cooked thoroughly before eating.
- **CAUTION** - eating raw or under cooked meat can cause food poisoning (e.g. bacteria strains such as E.coli).
- To reduce the risk of under cooked meat cut open to ensure it is cooked all the way through internally.
- **CAUTION** - if meat has been cooked sufficiently the meat juices should be clear in colour and there should be no traces of pink/red juices or meat colouring.
- Pre-cooking of larger meat of joints is recommended before finally cooking on your barbecue.
- After cooking on your pizza oven always clean the grill cooking surfaces and utensils.

Safety warning

- **WARNING** – Pellet pizza oven give off CARBON MONOXIDE when used, which is poisonous and can kill. DO NOT use a pizza oven indoors or either in a tent, caravan or awning.
- **WARNING** - Do not use indoors! OUTDOOR USE ONLY. Do not use the barbecue in a confined and/or habitable space e.g. houses, tents, caravans, motor homes, boats. Danger of carbon monoxide poisoning fatality.
- DO NOT use this product as a furnace.
- Ensure that the product is positioned on a permanent, flat, level, heat resistant non-flammable surface always from flammable items.
- Always stand your barbecue on a firm surface away from wooden fences or overhanging trees.
- Ensure the product has a minimum of 2 m overhead clearance and has a minimum of 2 m clearance from other surrounding items.
- **WARNING!** Do not use spirit or petrol for lighting or relighting! Use only firelighters complying to en 1860-3!
- DO NOT handle or move the product whilst alight as it will become hot.
- NEVER leave a burning fire unattended.
- Keep children and pets at a safe distance from the product when in use.
- Do not cook before the fuel has a coating of ash.
- The pizza oven shall be heated up and the fuel kept red hot for at least 15 minutes prior to the first cooking on the pizza oven.
- Be careful when handling metal parts of pizza oven as there are likely to become hot.
- Always use heat resistant gloves when handling the product.
- Ensure that the pizza oven has cooled down completely before removing ash.
- Keep a fine water sprayer at hand to extinguish any small flare-ups, otherwise use baking powder or salt to extinguish.
- To extinguish the unit - stop adding fuel and allow the fire in the pizza oven to die or douse with water.
- To prolong the life of your pizza oven grill do not leave it outside unprotected, use a suitable pizza oven cover when not in use.
- Do not store flammable materials near this product.
- Do not use aerosols near this pizza oven.
- Modification of the pizza oven may be dangerous, is not permitted, and will nullify any warranty.
- Failure to follow the instructions in this manual could result in serious injury or property damage.
- DO NOT use coal in this product.

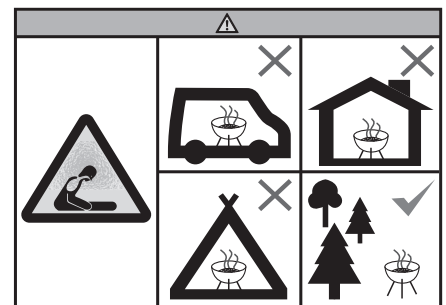

Use

01 Protection



02 Things to check before you start

1. Please dispose all plastic bags carefully and keep it away from children.
2. Check the part and make sure you have all of the parts listed. If not, contact your local B&Q store who will be able to help you.
3. Take a few moments to familiarize yourself with the contents & before starting check all holes are clear of any paint residue.
4. When you are ready to start, make sure that you have plenty of space and a clean dry area for assembly.



IMPORTANT - Whilst every care is taken in the manufacture of this product, care must be taken during assembly in case sharp edges are present.

03 Lighting procedures

1. Set the pizza oven up in a suitable position, on a level surface away from areas likely to catch fire. The base of the grill will get hot so ensure it stands on a suitable surface.
 2. Put the pellet grid into the combustion chamber.
 3. Place the pellets on the pellet grid and ignite the pellets on the top with refillable butane utility lighter.
 4. When the pellets are burning, put the combustion chamber into the body through the handle.
 5. Close the door so that the pellets burn completely to bake the pizza.
- When burning is established spread the fuel out evenly.



WARNING! The pellet will be very hot so take suitable precautions.

- Never touch metal parts which may be hot.
- Do not cook before the fuel has a coating of ash.

04 Before each cooking session

- To prevent foods from sticking to the cooking grill, please use a long handled brush to apply a light coat of cooking or vegetable oil before each barbecuing session.
- Fill the pellet fuel compartment with pellet, light the pellet and allow the pellet to become red-hot. It is recommended to wait for at least 15 minutes before cooking. Once the pellet has turn ash grey it is now ready to be used for cooking.

05 Replenishing the pellet

- During cooking, keep the pellet in hopper assembly more than half capacity of the hopper assembly.
- To replenish the pellet during use, use the handle to remove the hopper lid, then use the hopper shovel to take some pellets and pour them into the the hopper assembly. Place the hopper lid back on the hopper assembly with the handle.
- Make sure oven gloves or mitts are used.

06 Extinguishing the pizza oven

- Use water to extinguish when you have finished cooking.
- Ensure that the pizza oven has cooled down completely before removing charcoal ash.

Product maintenance

01 The golden rules for care

1. Good and regular care can extend the life and maintain the condition of your pizza oven.
2. Ensure the barbecue and its components are sufficiently cool before cleaning.



IMPORTANT - Please note that it is normal, when in use, that the coated metal surfaces on the pizza oven may discolour due to the heat generated by the burning pellet. The coating may appear to smoulder / smoke and the surfaces darken, turning a chalky or matt finish.

02 At the beginning of the season

- Check to ensure all components are secure.
- Check and tighten all screws and bolts.

03 Before each use

Check to ensure the cooking surfaces are clean & free from rust.

04 After each use

- To prolong the life of your pizza oven do not leave it outside unprotected, use a suitable pizza oven cover when not in use.
1. **Cooking surfaces (pizza stone, etc)**
Clean with hot, soapy water. To remove any food residue, use a mild cream cleaner on a non-abrasive pad. Rinse well and dry thoroughly. We do not recommend cleaning the pizza stone in a dishwasher.
 2. **Ash tray**
After every use, check the pellet fuel. Discard the ash, and wash any remaining ash or fat from the tray/collector. Failure to clean thoroughly may affect your cooking performance. Use the tool provided to remove the collector as it may be hot.
 3. **Pizza oven body**
Regularly remove excess grease or fat from the pizza oven body with a soft plastic or wooden scraper. It is not necessary to remove all the grease from the body. If you need to clean fully, use hot soapy water and a cloth, or nylon-bristled brush only. Remove pizza stone before full cleaning.
 4. **Log rack**
Apply a coat of vegetable oil on the surface.
 5. **After 2 or 3 uses**
Check and tighten all screws and bolts.

05 At the end of the season

- In order to extend the life and maintain the condition of your pizza oven, we strongly recommend that the unit be covered when left outside for any length of time, especially during the winter months.
- Do not leave the pizza oven exposed to outside weather conditions or stored in damp, moist areas.
- Do not store flammable materials near this product.

Exploded View

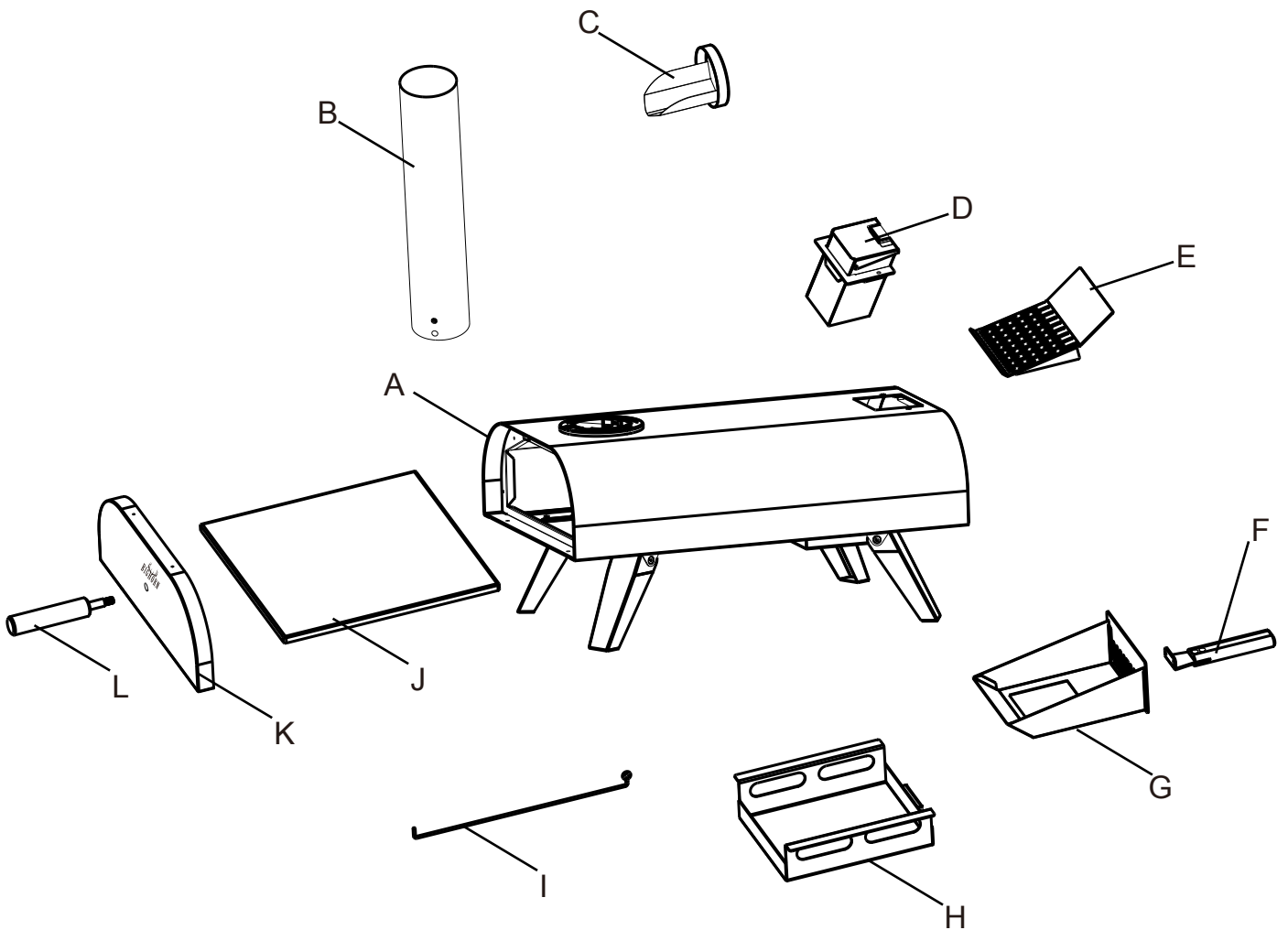

Parts List

PART	DESCRIPTION	QUANTITY
A	Pizza Oven Body Assembly	1
B	Chimney Pipe	1
C	Chimney Lid & Hopper Shovel	1
D	Hopper Assembly	1
E	Pellet Grid	1
F	Ash Tray Assembly Handle	1

PART	DESCRIPTION	QUANTITY
G	Ash Tray Assembly	1
H	Ash Tray	1
I	Poker	1
J	Pizza Stone	1
K	Door	1
L	Door Handle	1

Assembly Instructions

Step 1

With assistance, place the pizza oven body assembly (A) upside down on a soft, level surface.

Then open four legs (completed pre-installed) as illustrated.

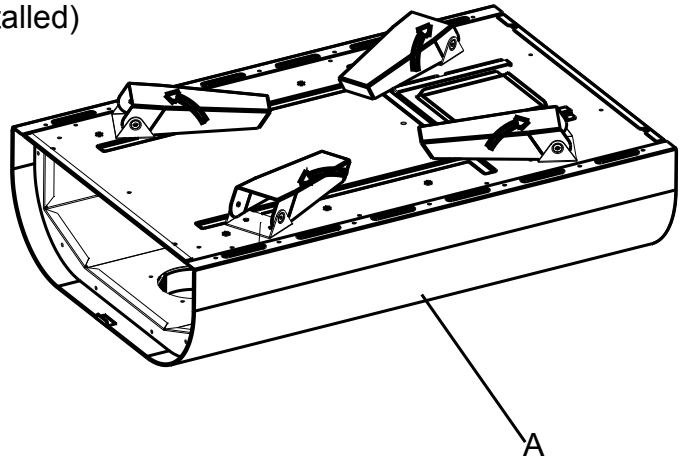

Step 2

Install the ash tray (H) to the pizza oven body assembly (A) as illustrated.

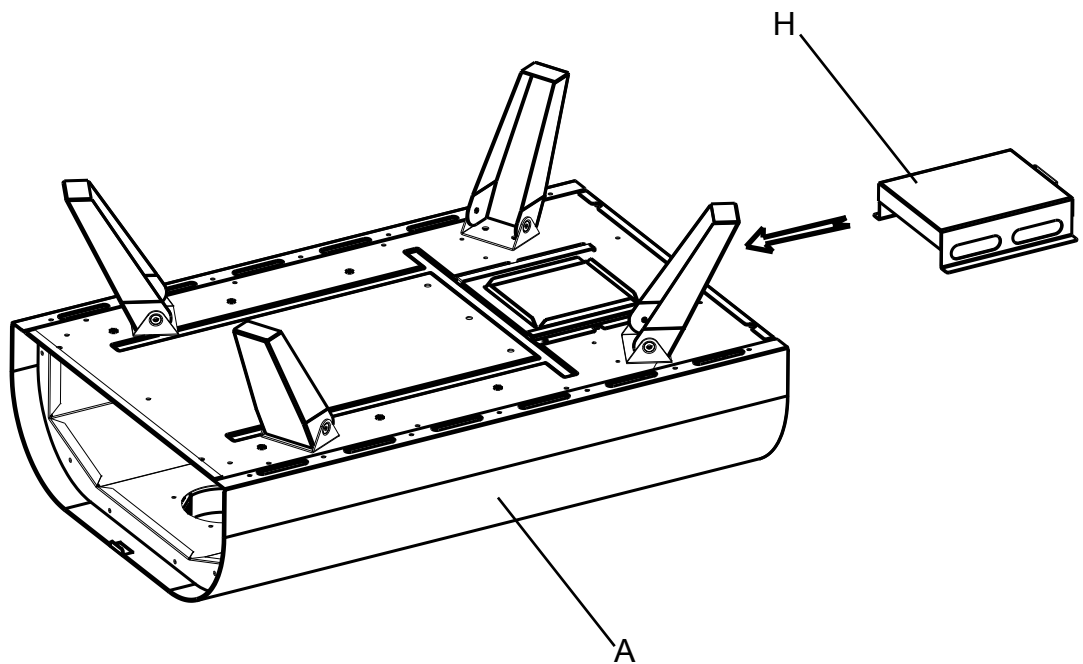

Assembly Instructions

Step 3

Flip over the pizza oven body assembly (A) as illustrated.

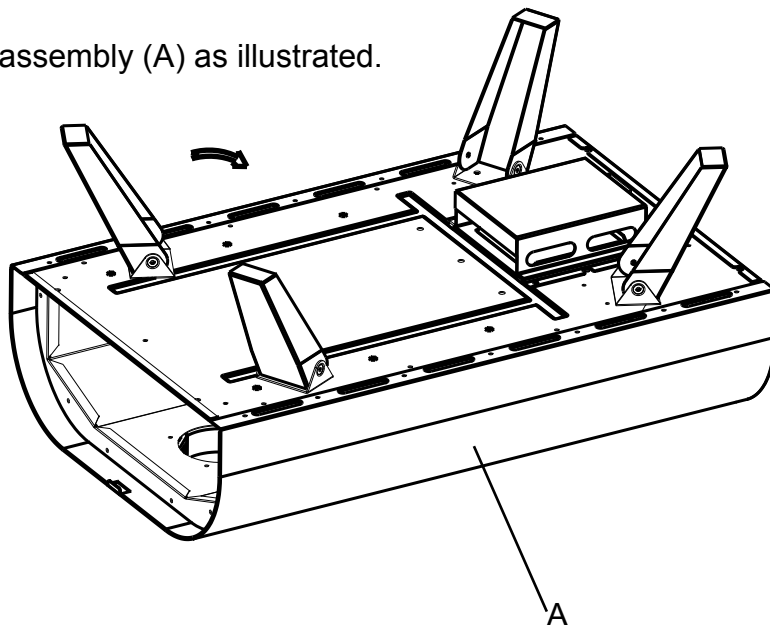

Step 4

Install the hopper assembly (D) to the pizza oven body assembly (A) with two M4×10 screws as illustrated.

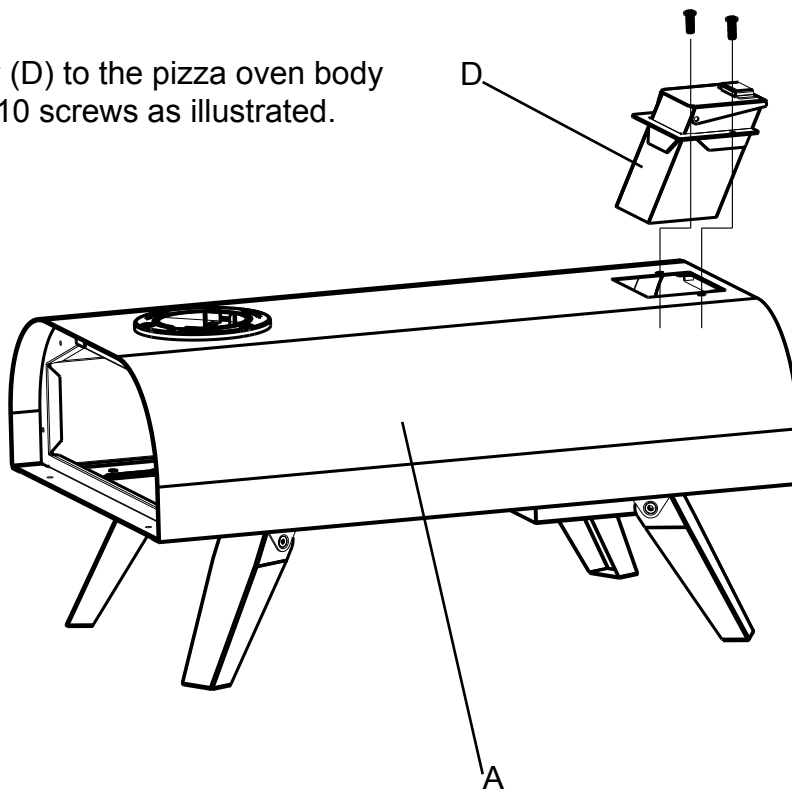

Assembly Instructions

Step 5

Put the pizza stone (J) into the pellet pizza oven assembly (A) as illustrated.

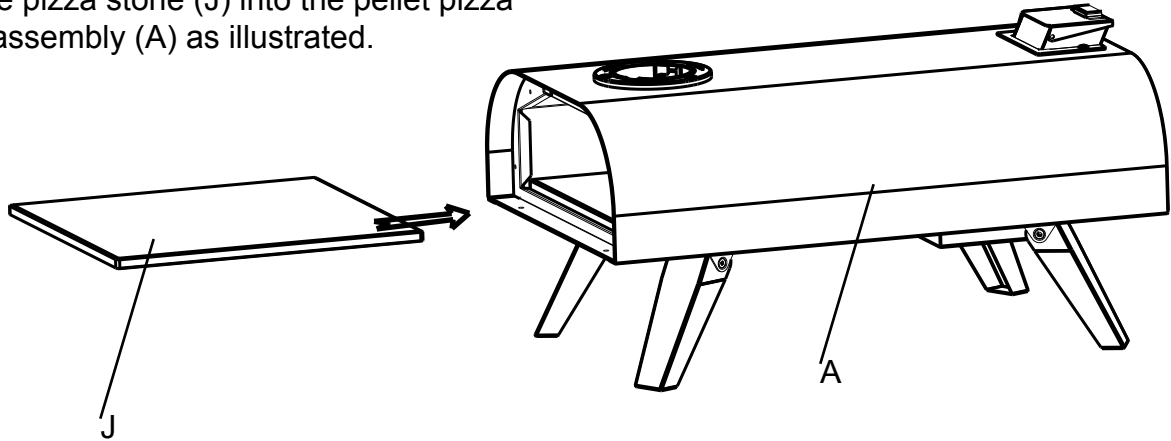

Step 6

Whirl the door handle (L) clockwise by hand to the door (K) as illustrated.

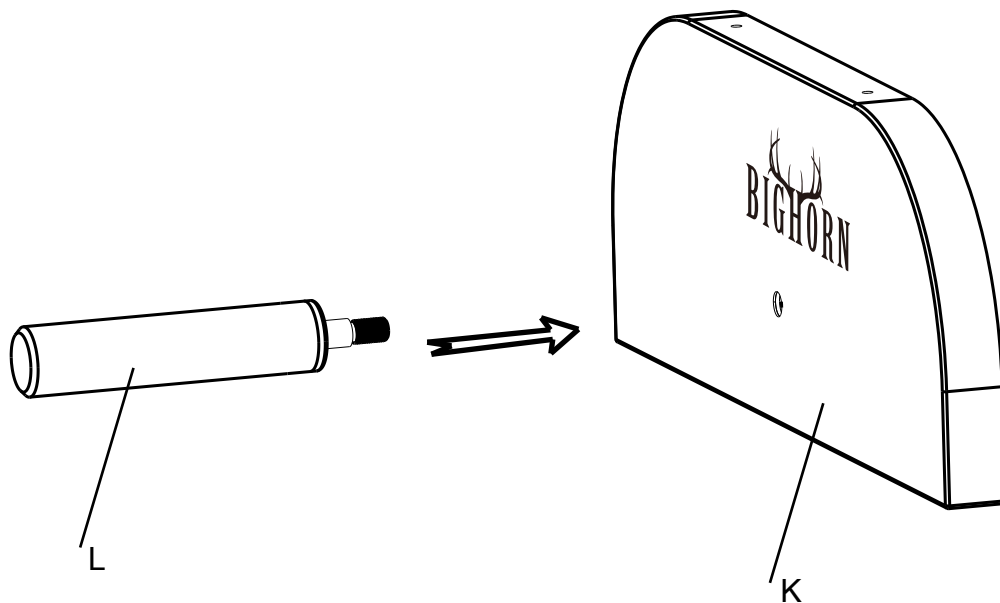

Assembly Instructions

Step 7

Install and whirl the chimney pipe (B) clockwise by hand to the pizza oven body assembly (A) as illustrated.

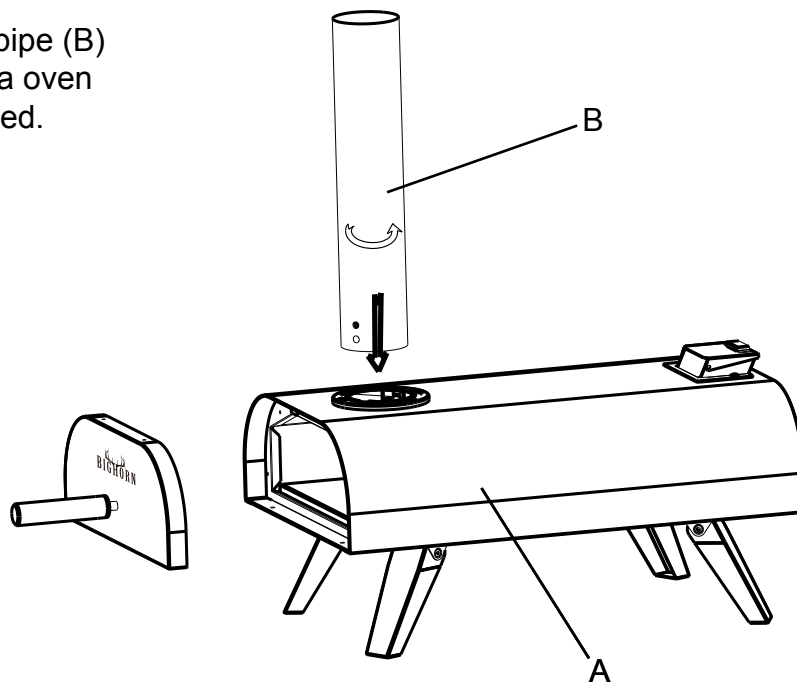

Step 8

Place the pellet grid (F) to the ash tray assembly (G) first, then put into the pizza oven body assembly (A) as illustrated.

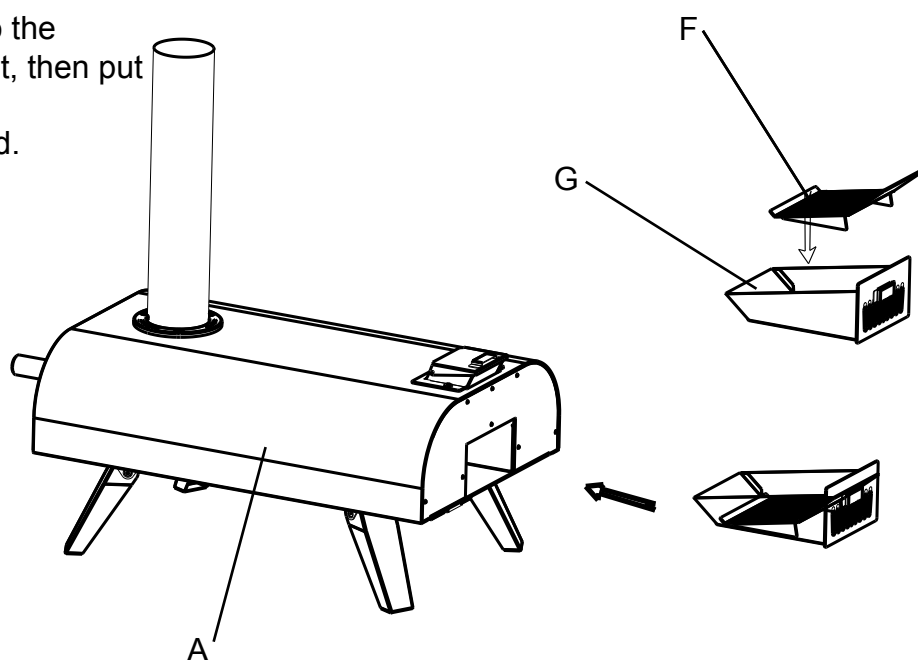

Assembly Instructions

Step 9

Install the ash tray assembly handle (F) to the pizza oven body assembly (A) as illustrated.

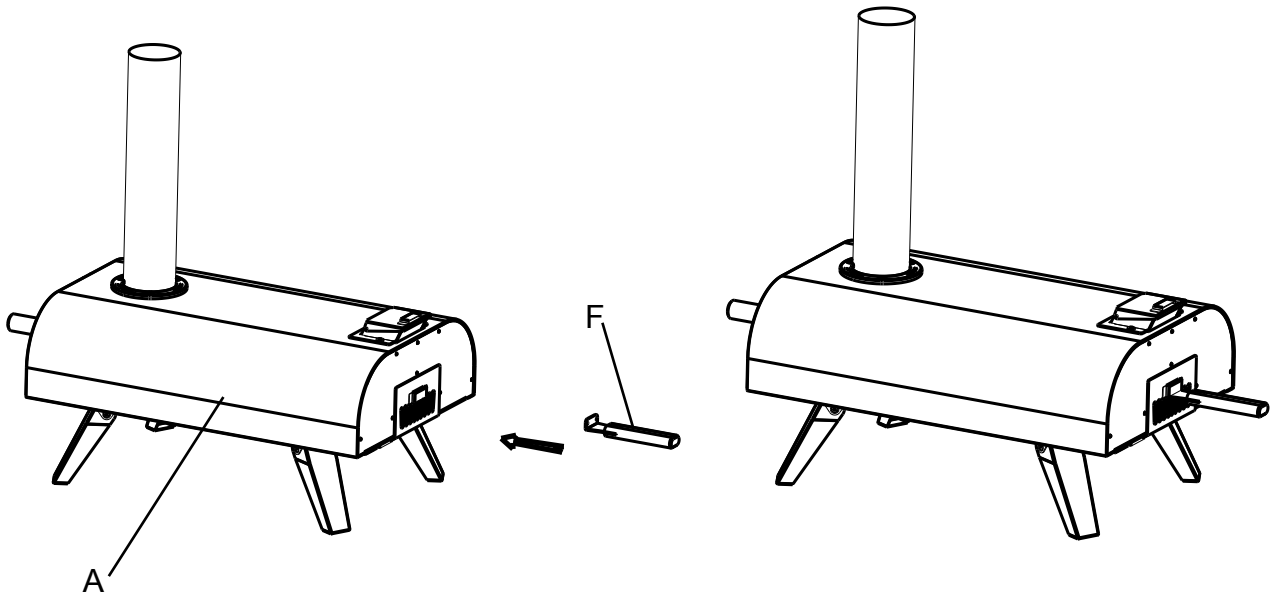

Step 10

The chimney lid & hopper shovel (C) can be used to cover the chimney pipe (B), or to shovel particles as illustrated.

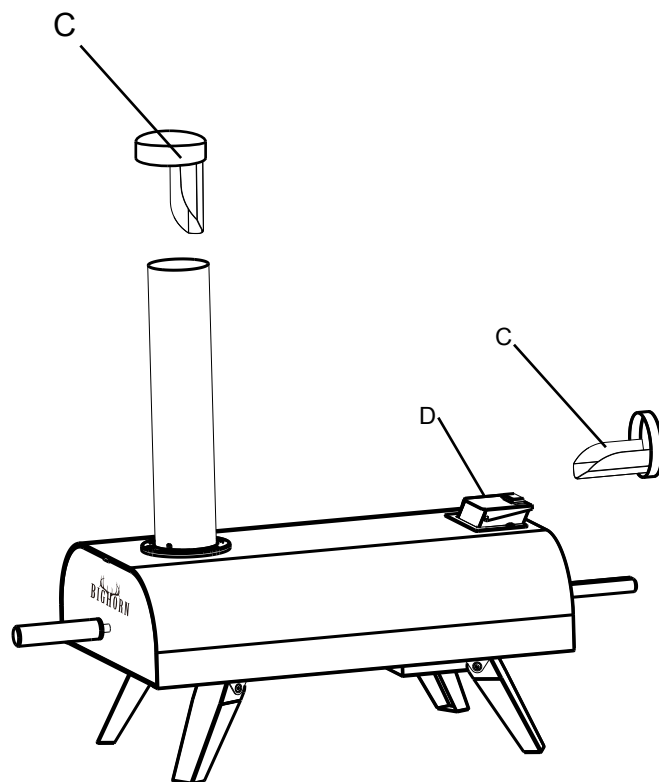

Warranty Information

The appliance has been manufactured under the highest standards of quality and workmanship. We warrant to the original consumer purchaser that all aspects of this product will be free of defects in material and workmanship for one year from the date of purchase. A replacement for any defective part will be supplied free of charge for installation by the consumer. Defects or damage caused by the use of other than genuine parts are not covered by this warranty. This warranty shall be effective from the date of purchase as shown in the purchaser's receipt.

This warranty is valid for the original consumer purchaser only and excludes industrial, commercial or business use of the product, product damage due to shipment or failure which results from alteration, product abuse, or product misuse, whether performed by a contractor, service company, or consumer. We will not be responsible for labor charges and / or damage incurred in installation, repair or replacement, nor for incidental or consequential damage.



Need help?
call our toll free number at:
1-888-909-3888 or
cs@shinerichgroup.com