

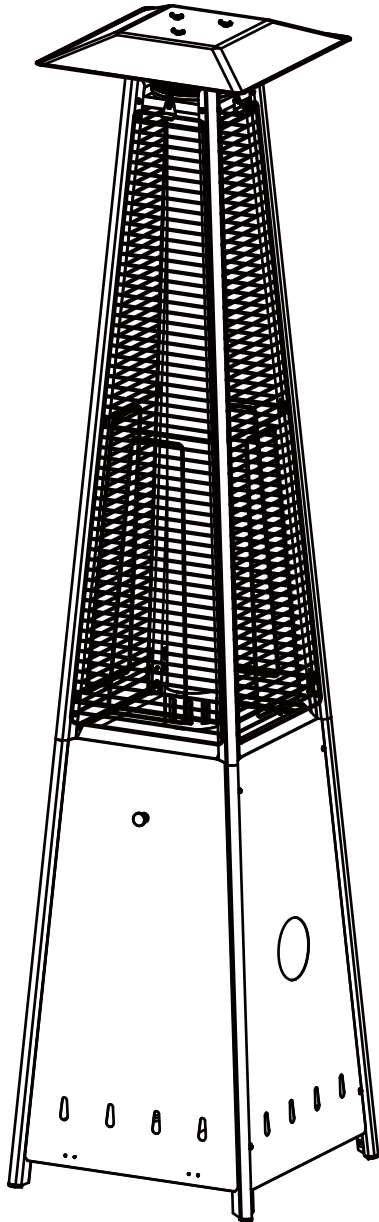

PYRAMID PATIO HEATER
Model# SRPH98
Instructions Manual



Owner's Manual

! DANGER

If you smell gas:

1. Shut off gas to the appliance.
2. Extinguish any open flame.
3. If odor continues, keep away from the appliance and immediately call your gas supplier or fire department.

! DANGER

Do not store or use gasoline or other flammable vapors and liquids in the vicinity of this or any other appliance.

An LP-cylinder not connected for use shall not be stored in the vicinity of this or any other appliance.

! WARNING

For Outdoor Use Only.

CAUTION:

Installer: Leave the manual instructions to the user for future use.

Consumer: Please keep this manual for future reference.

GAS-FIRED



Model#: SRPH98



Read the instructions before use.

This appliance must be installed in accordance with such regulations as are in force.



Questions, problems, missing / replacement parts? Before returning to your retailer call our customer service department at 1-888-909-3888, between 7:30am and 4:30pm PST, Monday through Friday.

WARNINGS AND CAUTIONS

 DANGER	CARBON MONOXIDE HAZARD
	<p>This appliance can produce carbon monoxide which has no odor.</p> <p>Using it in an enclosed space can kill you.</p> <p>Never use this appliance in an enclosed space such as a camper, tent or home.</p>

 **WARNING:** Improper installation, adjustment, alteration, service or maintenance can cause property damage, injury or death. Read the installation, operating and maintenance instructions thoroughly before installing or servicing this equipment.

SPECIFICATION

Certification	UL
Height	89.5" (2.27m)
Rated heat input	40,000 BTU/hr
Fuel	Propane
Gas Supply	20 lb (9 kg) LP gas cylinder
Manifold pressure	11" W.C .
Safety features	Flame failure device, anti-tilt switch
Gas supply pressure	Max. 250 PSI, Min. 5 PSI

WARNINGS AND CAUTIONS

NOTE: PLEASE READ THE FOLLOWING SAFETY RULES

WARNING:

The installation must conform with local codes or, in the absence of local codes, with the National Fuel Gas Code, ANSI Z223.1/NFPA 54, NFPA58 Natural Gas and Propane Installation Code, CSA B149.1, or Propane Storage and Handling Code, B149.2

The heater, when installed, must be electrically grounded in accordance with local codes or, in the absence of local codes, with the National Electrical Code, ANSI/NFPA 70, or the Canadian Electrical Code, CSA C22.1.

Prior to use, check for damaged parts such as hoses, regulators, pilot or burner.

All leak tests should be done with a soapy solution. NEVER USE AN OPEN FLAME TO CHECK FOR LEAKAGE.

The propane hose with regulator assembly shall be located out of pathways where people may trip over it or in areas where the hose will not be subject to accidental damage.

Children and adults should be alerted to the hazards of high surface temperatures and should stay away to avoid burns or clothing ignition.

Young children should be carefully supervised when they are in the area of the heater.

Clothing or other flammable materials should not be hung from the heater, or placed on or near the heater.

Any guard or other protective device removed for servicing the heater must be replaced prior to operating the heater.

Installation and repair should be done by a qualified service person. The heater should be inspected before use and at least annually by a qualified service person.

More frequent cleaning may be required as necessary. It is imperative that control compartment, burners and circulating air passageways of the heater be kept clean.

Keeping the appliance area clear and free from combustible materials, gasoline and other flammable vapors and liquids.

Not obstructing the flow of combustion and ventilation air.

Keeping the ventilation opening(s) of the cylinder enclosure free and clear from debris.

This appliance shall be used only in a well-ventilated space and shall not be used in a building, garage or any other enclosed area.

An appliance may be installed with shelter no more inclusive than:

With walls on all sides, but with no overhead cover.

Within a partial enclosure which includes an overhead cover and no more than two side walls. These side walls may be parallel, as in a breezeway, or at right angles to each other.

WARNINGS AND CAUTIONS

NOTE: PLEASE READ THE FOLLOWING SAFETY RULES

WARNING:

Within a partial enclosure which includes an overhead cover and three side walls, as long as 30 percent or more of the horizontal periphery of the enclosure is permanently open.

This appliance requires 9kg(20lb) LP-gas supply cylinder.

The LP-gas supply cylinder to be used must be: Constructed and marked in accordance with the Specifications for LP-gas cylinders of the U.S. Department of Transportation (DOT); or the Standard for Cylinders, Spheres and Tubes for Transportation of Dangerous Goods and Commission, CAN/CSA-B339, as applicable;

Provided with a listed overfilling prevention device; and provided with a cylinder connection device compatible with the connection for the appliance.

Ensure that the cylinder is disconnected when the appliance is not in use.

Storage of an appliance indoors is permissible only if the cylinder is disconnected and removed from the appliance.

A cylinder must be stored outdoors in a well-ventilated area out of the reach of children. A disconnected cylinder must have dust caps tightly installed and must not be stored in a building, garage or any other enclosed area.

Appliance may shut down in windy conditions in excess of 3 miles per hour (4.83 kilometers per hour).

The pressure regulator and hose assembly supplied with the appliance must be used, replacement pressure regulators and hose assemblies must be those specified by the appliance manufacturer.

Do not store a spare LP-gas cylinder under or near this appliance;

Never fill the cylinder beyond 80 percent full;

Do not clean the heater with cleaners that are combustible or corrosive.

Place the dust cap on the cylinder valve outlet whenever the cylinder is not in use. Only install the type of dust cap on the cylinder valve that is provided with the cylinder valve. Other types of caps or plugs may result in leakage of propane.

Certain materials or items, when stored under the heater, will be subjected to radiant heat and could be seriously damaged.

Inspect the visible portion of the hose before each use of the appliance and inspect the entire hose assembly at least annually.

The cylinder used must include a collar to protect the cylinder valve.

Installation of this appliance at altitudes above 2000 ft (610m) shall be in accordance with local codes, or in the absence of local codes, ANSI Z223.1/NFPA 54 or CSA B149.1.

WARNINGS AND CAUTIONS

NOTE: PLEASE READ THE FOLLOWING SAFETY RULES:

Perform a leak test with a soapy solution:

1. To check gas connections.
2. After connecting a new cylinder.
3. Upon re-assembly after disassembly.

This heater is designed to operate with a standard 20 lb propane cylinder with Approved Cylinder Connection.

WARNING

This product can expose you to chemicals including Lead and Lead Compounds, which are known to the state of California to cause cancer, and Carbon Monoxide, Lead and Lead Compounds which are known to the state of California to cause birth defects or other reproductive harm. For more information go to www.P65Warnings.ca.gov

PREPARATION

Before beginning assembly of product, make sure all parts are present. If any part is missing or damaged, do not attempt to assemble the product. Contact customer service for replacement parts.

Every part of the heater shall be secure against displacement and shall be constructed to maintain a fixed relationship between essential parts under normal and reasonable conditions of handling and usage. Parts not permanently secured shall be designed so they cannot be incorrectly assembled and cannot be improperly located or misaligned in removing or replacing during cleaning or other servicing.

TOOLS NEEDED:

Adjustable open end wrench (NOT INCLUDED)

Philips screwdriver



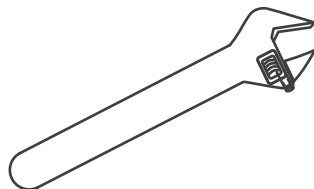
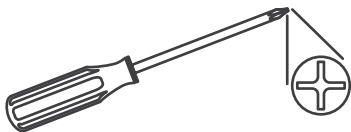



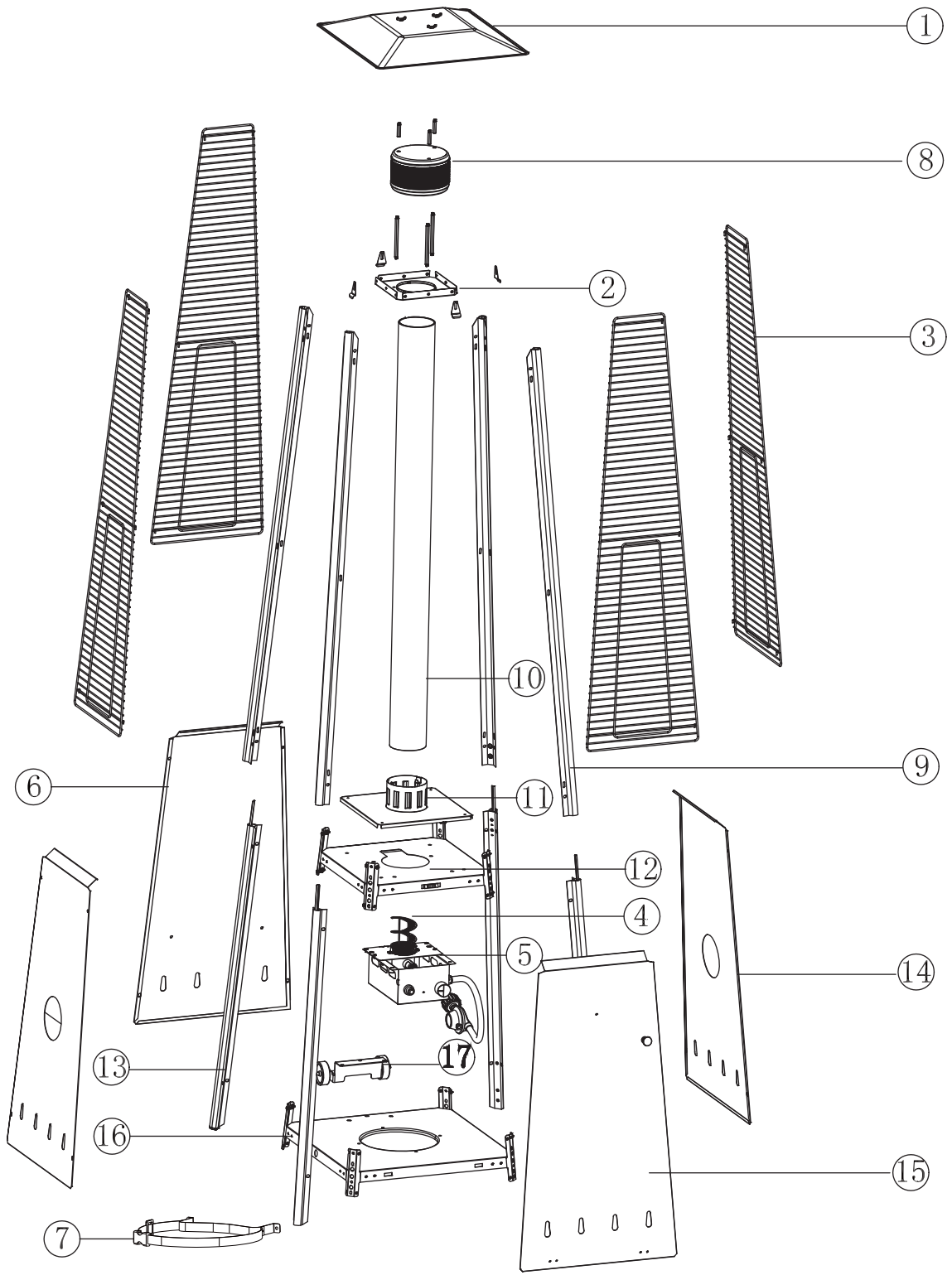





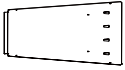

Estimated time for assembly: 30 minutes.



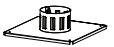

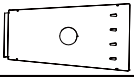









EXPLODED VIEW



PARTS & HARDWARE

Part #	Description	Picture	Qty
1	Reflector		1
2	Upper Plate		1
3	Mesh		4
4	Spiral		1
5	Burner Assembly		1
6	Back Panel		1
7	Gas Cylinder Holder		1
8	Fire Damper		1
9	Upper Support		4
10	Glass Tube		1
11	Glass Tube Base		1
12	Middle Plate		1
13	Lower Support		4
14	Left and Right Panel		2
15	Front Panel		1
16	Bottom Plate		1
17	Wheel Assembly		1

Part #	Description	Picture	Qty
AA	M5 Wing Nut		3
BB	M5 Stud		3
CC	M5 x 12 Screw		68
DD	M5 Nut		3
EE	Guard Bracket		4
FF	M5 Bolt		3
GG	Handle		1
HH	M4 x 25 Screw (pre-assembly)		4
II	M8 x 10 Screw (pre-assembly)		3
JJ	M8 Nut (pre-assembly)		3
KK	8.5 Washer (pre-assembly)		3
LL	M4 x 10 Screw (pre-assembly)		1
MM	Philips screwdriver		1



ASSEMBLY INSTRUCTIONS

Step 1

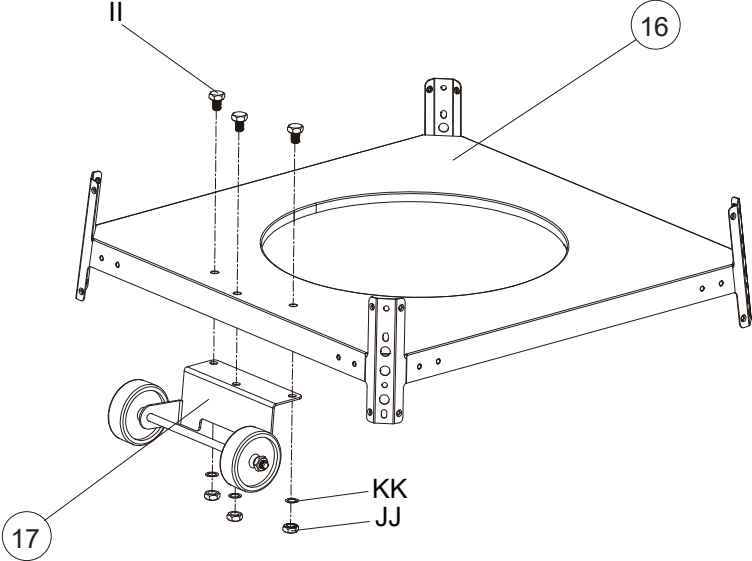
Unscrew the pre-assembled screws, nuts and washers on the wheel assembly (#17), then attach the wheel assembly (#17) to the bottom plate (#16) with (3) M8 x 10 screws (II), (3) M8 nuts (JJ) and (3) 8.5 washers (KK) as illustrated.



Hardware Used

II		M8 x 10 Screw (pre-assembly)	3 pcs
JJ		M8 Nut (pre-assembly)	3 pcs
KK		8.5 Washer (pre-assembly)	3 pcs

Step 2

Attach (4) lower supports (#13) to the bottom plate (#16) with (12) M5 x 12 screws (CC) as illustrated.

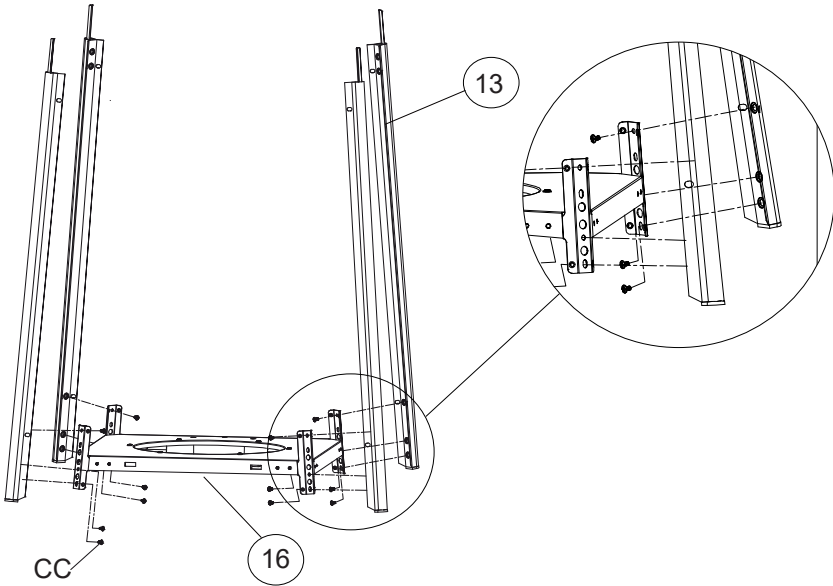

Hardware Used

CC		M5 x 12 Screw	12 pcs
----	---	---------------	--------

ASSEMBLY INSTRUCTIONS

Step 3

Unscrew the pre-assembled M4 x 25 screws (HH) on the glass tube base (#11), then remove the glass tube base (#11) from the middle plate (#12), and put the M4 x 25 screws (HH) and the glass tube base (#11) aside for Step 7.

Attach the middle plate (#12) to the lower supports (#13) with (8) M5 x 12 screws (CC) as illustrated.

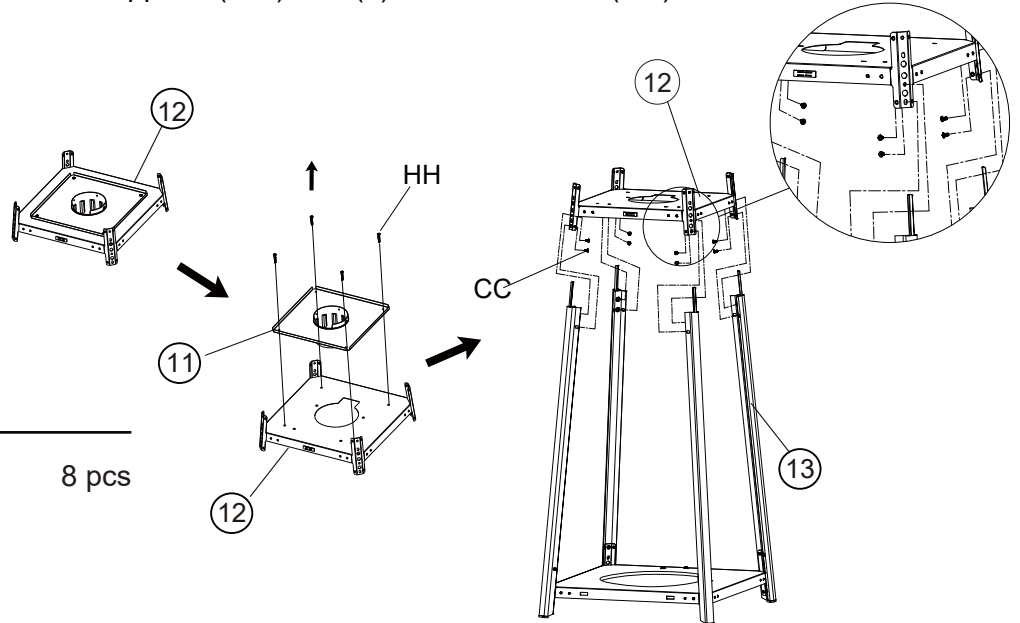

Hardware Used

CC  M5 x 12 Screw 8 pcs

Step 4

Attach (4) upper supports (#9) to the lower supports (#13) with (16) M5 x 12 screws (CC) as illustrated.

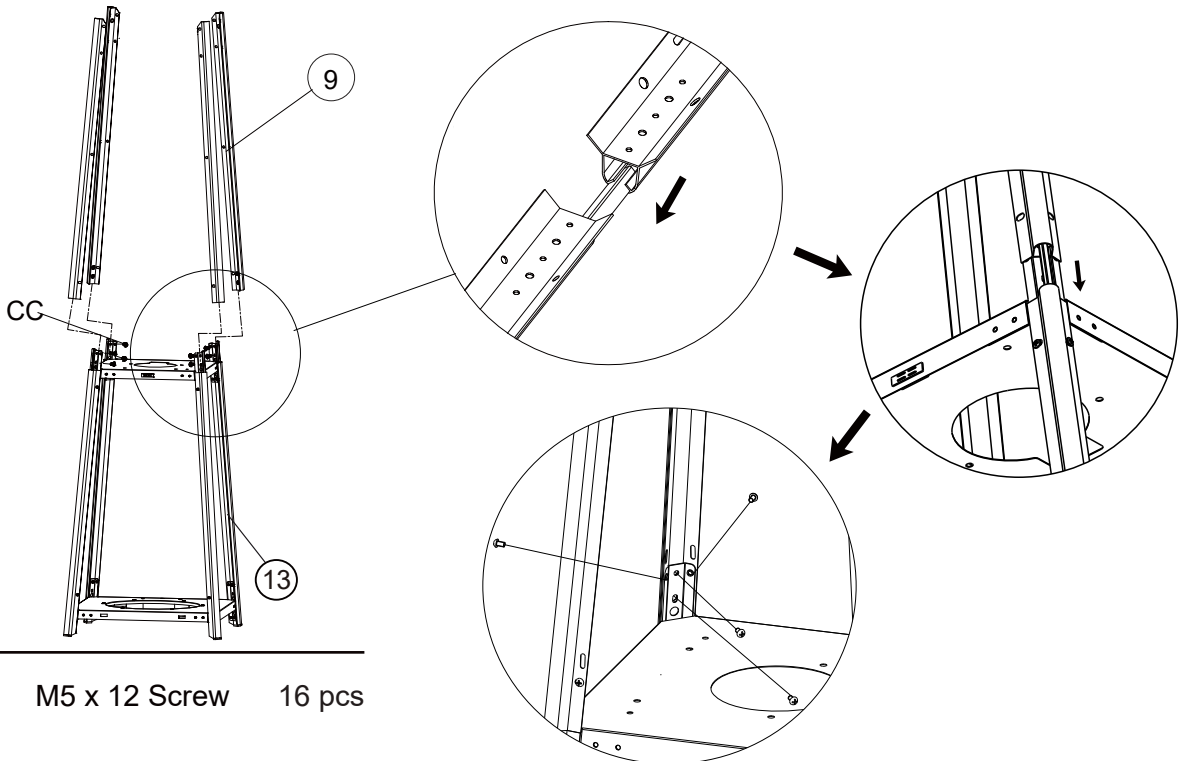

Hardware Used

CC  M5 x 12 Screw 16 pcs

ASSEMBLY INSTRUCTIONS

Step 5

Attach the upper plate (#2) to the upper supports (#9) with (8) M5 x 12 screws (CC) as illustrated.

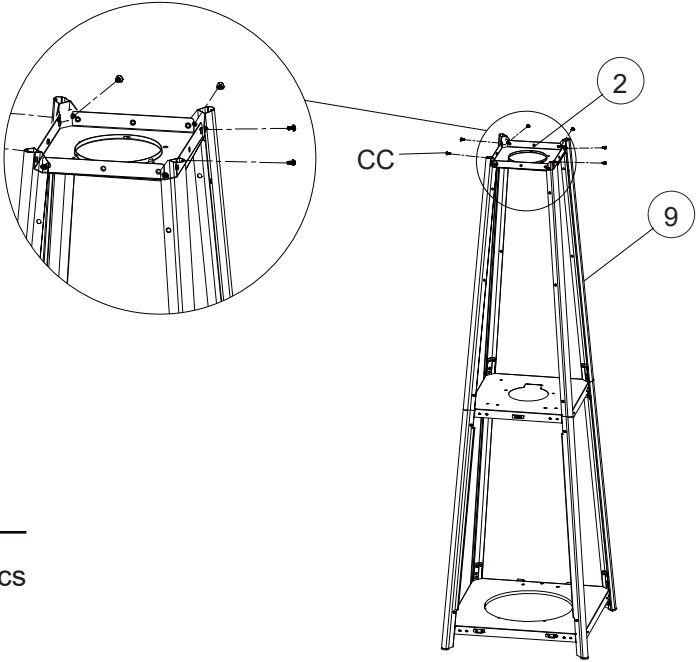

Hardware Used

CC		M5 x 12 Screw	8 pcs
----	---	---------------	-------

Step 6

Attach the fire damper (#8) to the upper plate (#2) with (3) M5 bolts (FF) and (3) M5 nuts (DD), then attach the reflector (#1) to the fire damper (#8) with (3) M5 wing nuts (AA) and (3) M5 studs (BB) as illustrated.

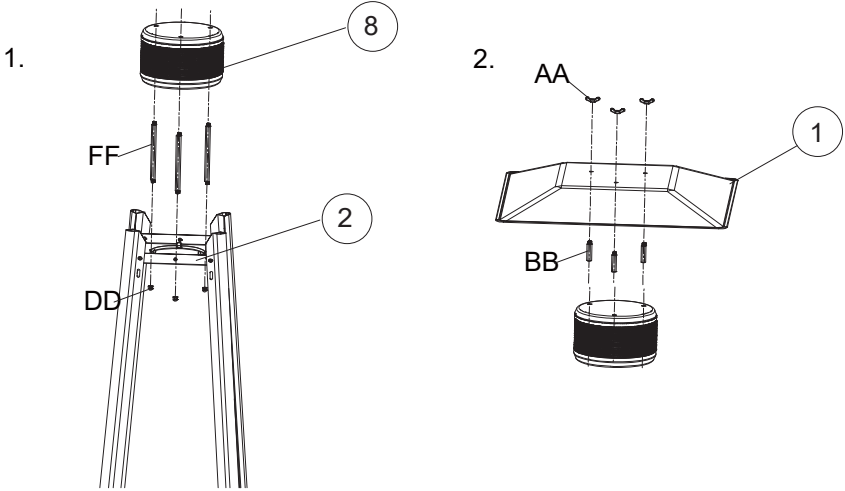

Hardware Used

AA		M5 Wing Nut	3 pcs
BB		M5 Stud	3 pcs
FF		M5 Bolt	3 pcs
DD		M5 Nut	3 pcs

ASSEMBLY INSTRUCTIONS

Step 7

Attach the glass tube base (#11) to the middle plate (#12) with (4) M4 x 25 screws (HH) as illustrated.

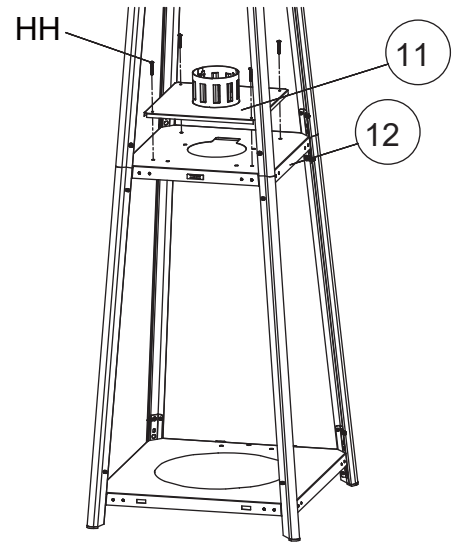

Hardware Used

HH		M4 x 25 Screw	4 pcs (pre-assembly)
----	---	---------------	-------------------------

Step 8

Attach the spiral (#4) to the burner assembly (#5) with (2) M5 x 12 screws (CC), then attach the burner assembly (#5) to the middle plate (#12) with (4) M5 x 12 screws (CC) as illustrated.

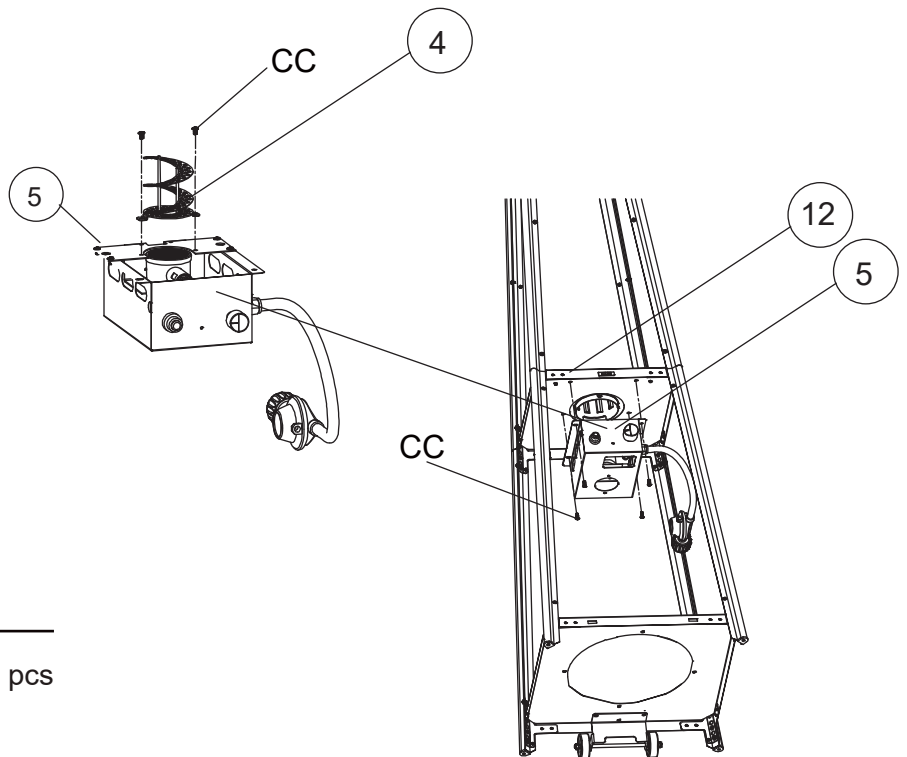

Hardware Used

CC		M5 x 12 Screw	6 pcs
----	---	---------------	-------

ASSEMBLY INSTRUCTIONS

Step 9

Attach the gas cylinder holder (#7) to the back panel (#6) with (2) M5 x 12 screws (CC) as illustrated

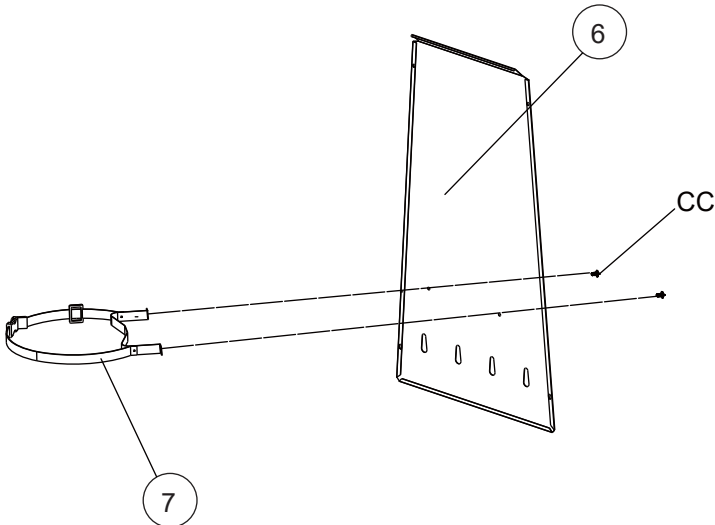

Hardware Used

CC		M5 x 12 Screw	2 pcs
----	---	---------------	-------

Step 10

Attach the back panel (#6), left and right panel (#14) to the lower supports (#13) with (12) M5 x 12 screws (CC) as illustrated.

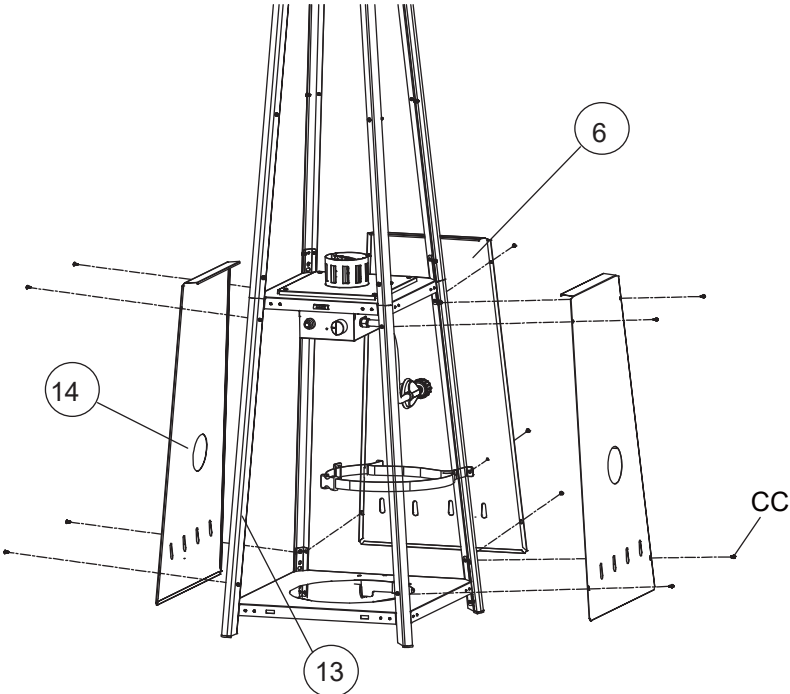

Hardware Used

CC		M5 x 12 Screw	12 pcs
----	---	---------------	--------

ASSEMBLY INSTRUCTIONS

Step 11

Place the glass tube (#10) by guiding it up to insert the upper end through the center hole in the upper plate. Do not force the tube. Slide the bottom end into place and settle it into the hole in the glass tube base. Ensure that the Glass Tube is positioned properly to cover the spiral.

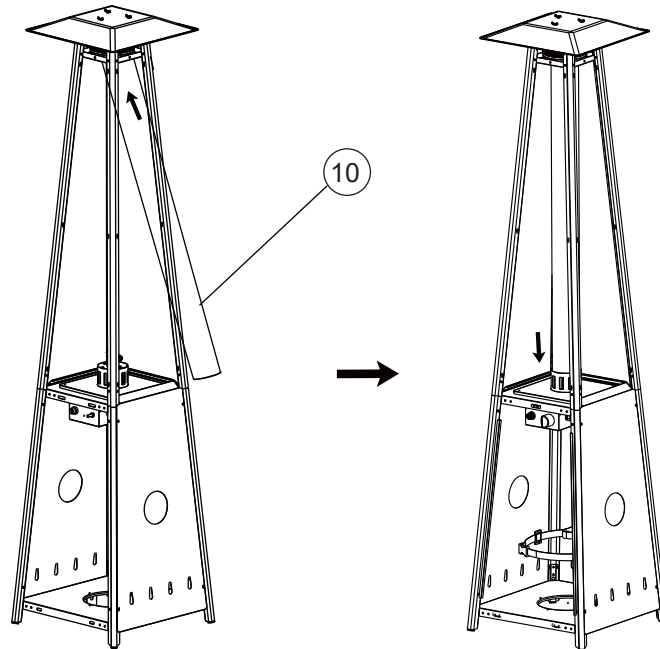

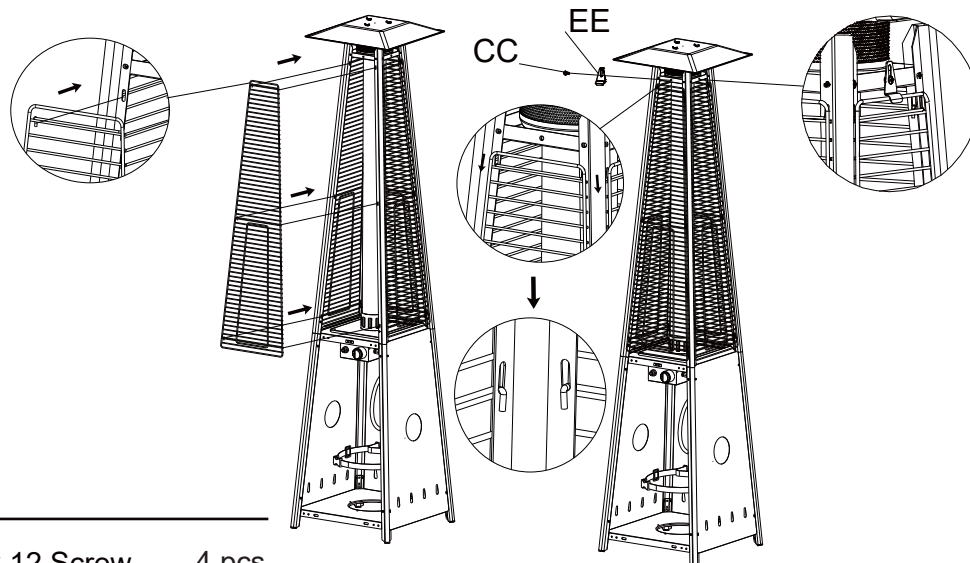

Step 12

Attach (4) meshes (#3) to the upper supports with (4) M5 x 12 screws (CC) and (4) guard brackets (EE) as illustrated.



Hardware Used

CC		M5 x 12 Screw	4 pcs
EE		Guard Bracket	4 pcs

ASSEMBLY INSTRUCTIONS

Step 13



Unscrew the pre-assembled M4 x 10 screw (LL) on the handle (GG), then attach the handle (GG) to the front panel (#15) with M4 x 10 screw (LL).

Install the front panel (#15) by inserting the two tabs at the bottom into the holes on the front of the bottom plate (#16). Attach the chain between inside of the door handle and the front of the burner assembly, then close the panel. The panel secures with magnet.

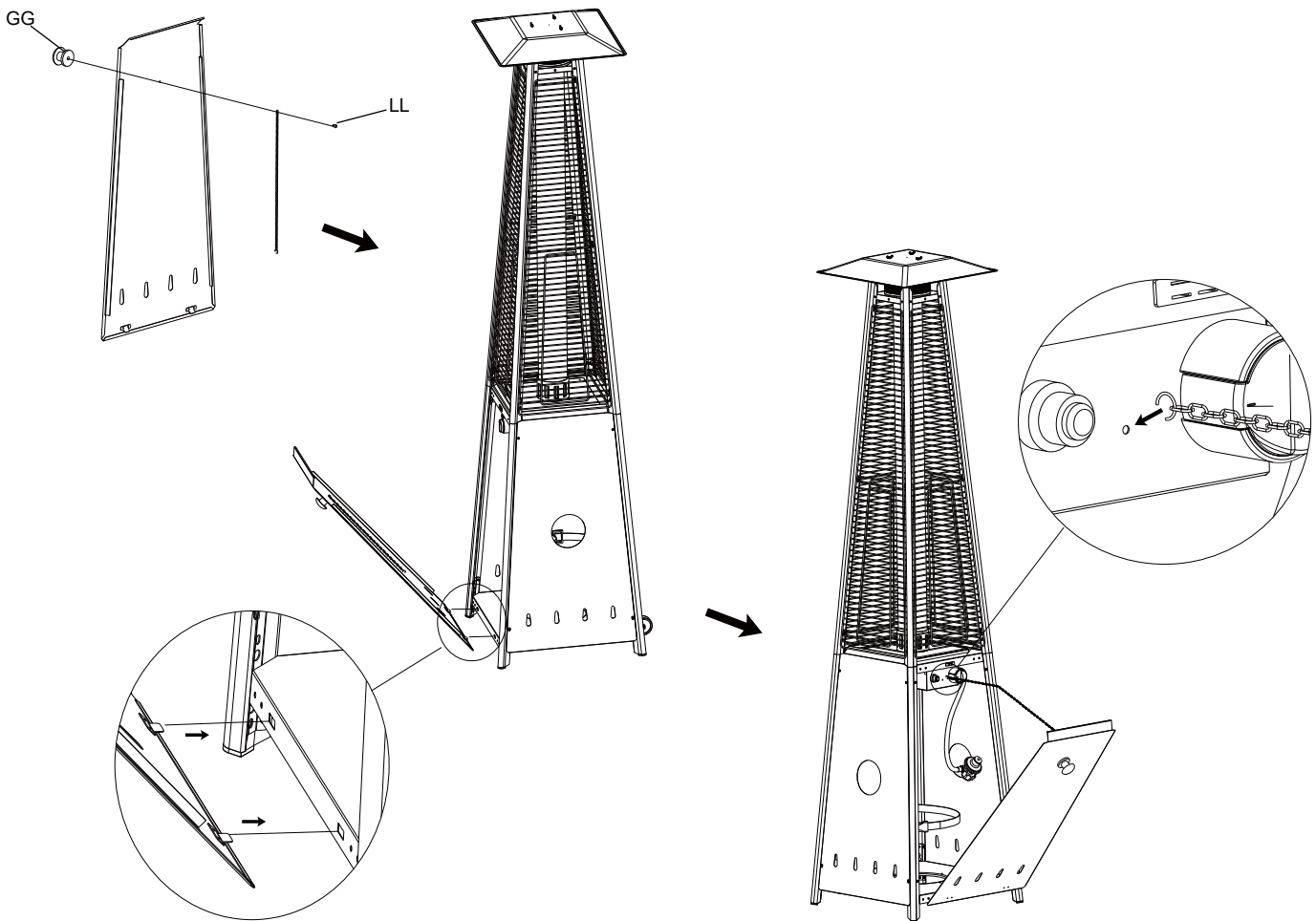
NOTE: The chain is used to support the front panel while operating the controls.



Hardware Used

LL		M4 x 10 Screw (pre-assembly)	1 pc
GG		Handle	1 pc

ASSEMBLY INSTRUCTIONS

Step 14

When installing an LPG cylinder, it may be easier to remove the Front Panel completely and set aside. Place the cylinder on the Bottom Plate. Connect the gas hose to 20lb LPG cylinder (not included). Screw the regulator to the cylinder as illustrated. Tighten securely with the Fastening Belt.

NOTE: The regulator with gas hose is supplied.

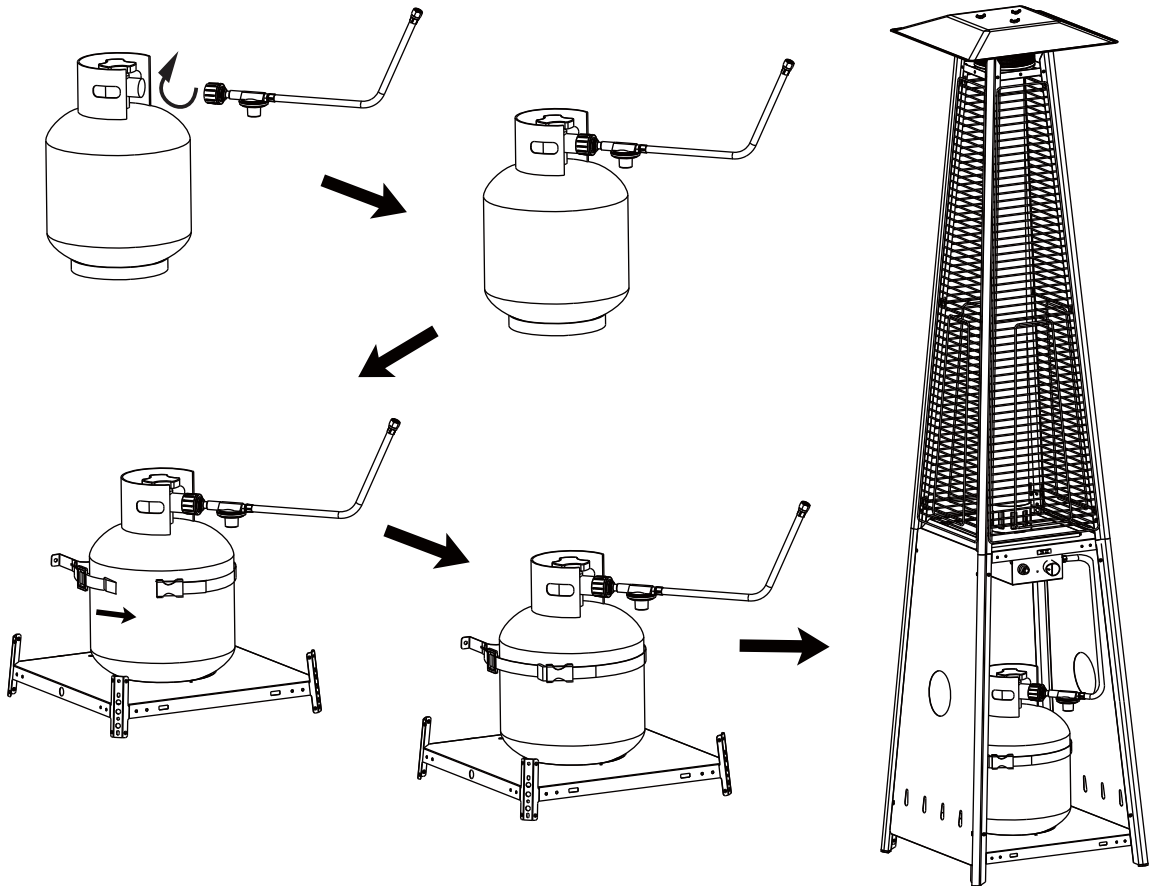

SAFETY CHECK

! WARNING : ONLY AN AUTHORIZED GAS TECHNICIAN SHOULD INSTALL THIS PRODUCT.

Check for leaks

All connection on the patio heater have been checked for leakage at the factory. Follow these steps to check the gas hose/regulator/cylinder connections:

- 1) Make leakage solution by mixing 1 part liquid dish soap and 3 parts water.
- 2) Spoon or brush several drops (or use squirt bottle) of the solution onto hose connection, regulator & cylinder connection.
- 3) Turn on gas cylinder valve. Inspect the connections and look for bubbles.
- 4) If no bubbles appear, the connection is safe.
- 5) If bubbles appear, there is leakage. Loosen and re-tighten this connection. If connection still leaks, please call customer service:
1-888-909-3888

Note:

- 1) The cylinder supply system must be arranged for vapor withdrawal;
- 2) The cylinder used must include a collar to protect the cylinder valve.

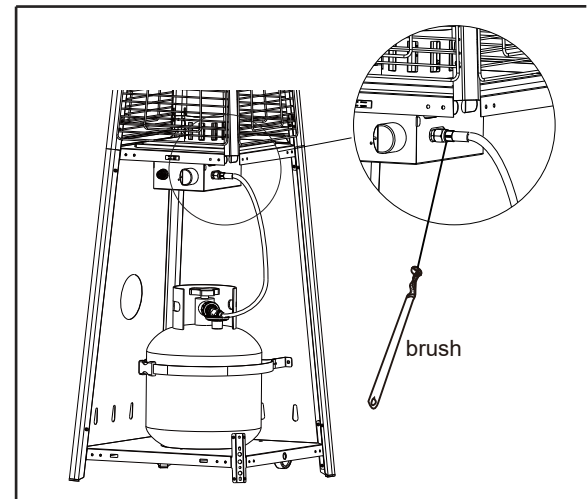
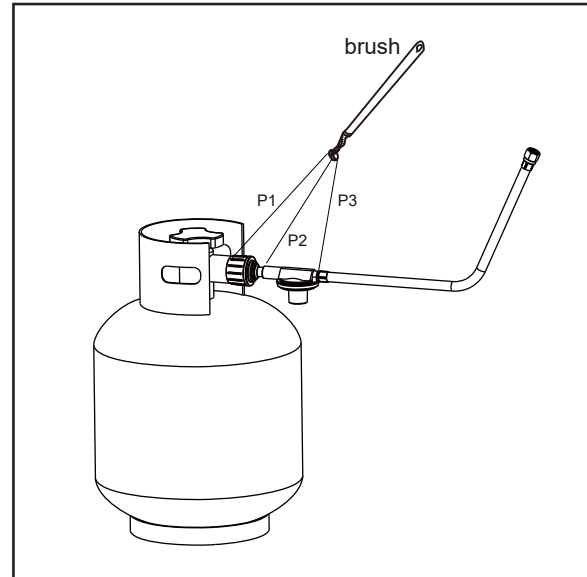

OPERATION

⚠ WARNING: DO NOT ATTEMPT TO OPERATE THE APPLIANCE UNTIL YOU HAVE READ AND UNDERSTAND ALL PRECAUTIONS. FAILURE TO DO SO CAN RESULT IN PROPERTY DAMAGE, SERIOUS INJURY, OR DEATH.

Before turning gas supply ON

Your heater was designed and approved for OUTDOOR USE ONLY. DO NOT use it inside a building or any other enclosed area.

Make sure surrounding areas are free of combustible materials, gasoline, and other flammable vapors or liquids.

Ensure that there is no obstruction to air ventilation.

Be sure all gas connections are tight and there are no leaks.

Be sure the access panel is clear of debris.

Be sure any component removed during assembly or servicing is replaced and fastened prior to starting.

Before Lighting

Heater should be thoroughly inspected before each use, and by a qualified service person at least annually.

If relighting a hot heater, always wait at least 5 minutes.

Lighting instructions

Unscrew the cap of the igniter placed on the control box and insert the included AAA battery with the POSITIVE end facing out.

⚠ WARNING

FOR YOUR SAFETY:

If at any time you are unable to light burner and smell gas, wait 5 minutes to allow gas to dissipate before attempting to light heater. If after 1 minute, you are unable to light burner, wait 5 minutes and allow flammable vapors to dissipate before attempting to light heater.

⚠ WARNING

FOR YOUR SAFETY:

DO NOT touch or move heater for at least 45 minutes after use. Allow emitter and dome to cool before touching.

⚠ WARNING

Lighting operations should comply with Lighting Instruction section. Improper lighting operations will cause serious injury and explosion.

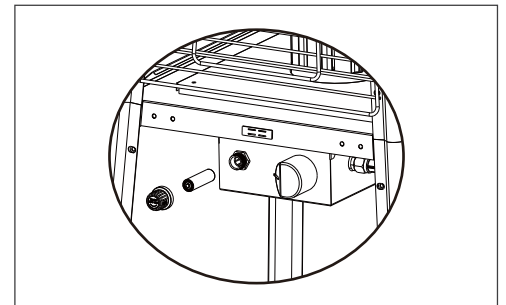

OPERATION

1. Make sure control knob is in the "OFF" position.
2. Turn LP cylinder gas valve to fully open position.
3. Push in control knob and turn counter-clockwise to "IGNITE" position, at the same time push in the ignition button and keep the control knob depressing until lighting the burner.
4. If the burner is lit, keep press down the ignition button for 30 seconds before releasing control knob.
5. If the burner is not lit, press down the control knob and turn clockwise to "OFF" position, repeat from step 3 after 5 minutes.
6. When burner is lit, turn the control knob to desired heat output position between "LOW" and "HIGH".
7. Press down and turn the control knob clockwise to "OFF" position to shut down the appliance.
Turn off cylinder gas valve.

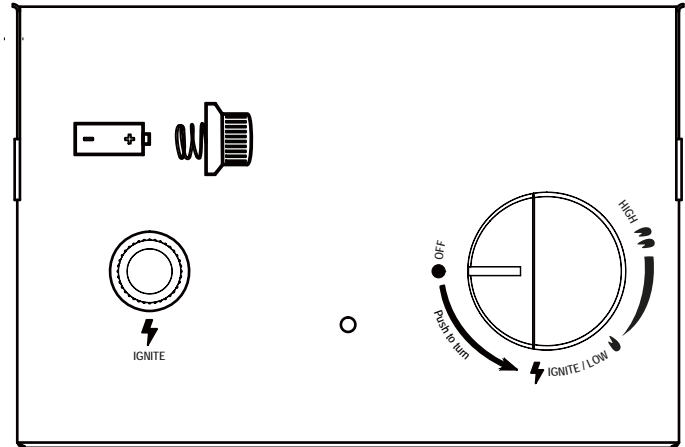

These lighting instructions must be followed. An unsafe condition can occur if they are not followed correctly.

Flame Characteristic

The flame pattern at the emitter screen should be visually checked whenever heater is operated. Normally the burner flame is yellow.

If flames extend beyond surface of the emitter grid, or the phenomena of flame lift or light back, or black spot is accumulating on the emitter grid or reflector, the heater should be **turned off** immediately. The heater should not be operated again until the unit is serviced and or repaired.

LOCATION SAFETY INFORMATION

Minimum clearance from combustible surfaces

This heater is primarily used for the heating of outdoor patios, decks, spas, pools and open working areas.

Combustible materials are considered to be wood, compressed parter, plant fibres, plastic or other materials that are capable of being ignited and burned.

Always make sure that adequate fresh air ventilation is provided. Follow the spacing tolerances shown in the following figure right at all times.

This heater must be placed on level, firm ground.

Never operate in an explosive atmosphere.

Keep away from areas where gasoline or other flammable liquids or vapors are stored or used.

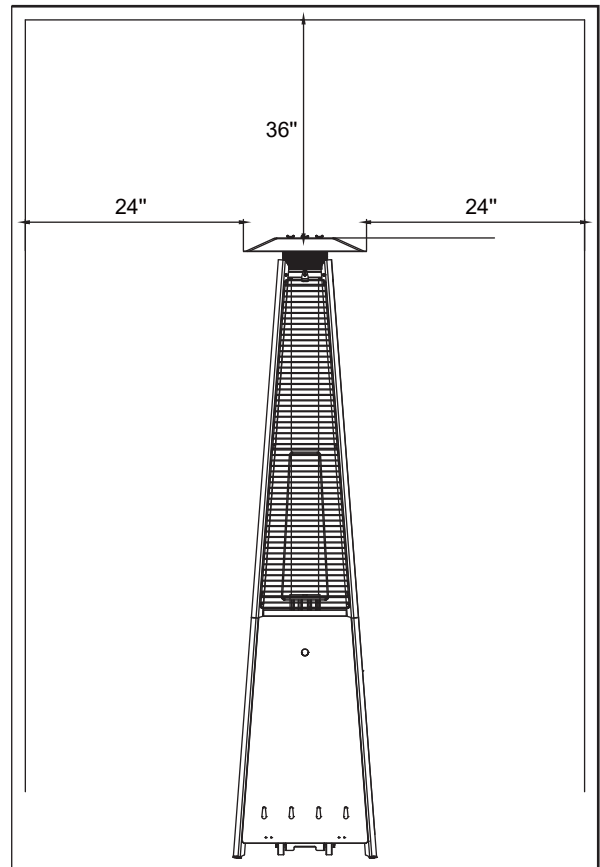

MAINTENANCE/STORAGE

CLEANING AND MAINTENANCE :

To enjoy years of outstanding performance from your heater make sure you perform the following maintenance activities on a regular basis:

- Keep exterior surfaces clean.
- Use warm soapy water for cleaning. Never use flammable or corrosive cleaning agents.
- While washing your unit, be sure to keep the area around the burner and pilot assembly dry at all times. If the gas control is exposed to water in any way, do NOT try to use it. It must be replaced.
- Keep the appliance area free and clean from combustible materials, gasoline and other flammable vapors and liquids; not obstructing the flow of combustion and ventilation air; keeping the ventilation opening(s) of the cylinder enclosure free and clear from debris.
- Visually checking burner flames.
- Cleaning the appliance, including special surfaces, with recommended cleaning agents, if necessary.
- Lubrication of moving parts and the type and amount of lubricant to be used.
- When applicable, visually checking portions of the hose assembly located within the confines of the heater post.
- Check if there are cracks or worn sections on hose. If yes, please call our customer service to replace hose.
- **At least once a year, the unit should be inspected** for the presence of spiders, spider webs or other insects.
- Air flow must be unobstructed. Keep controls, burner, and circulating air passageways clean. Signs of possible blockage include:
 - Gas odor with extreme yellow tipping of flame.
 - Heater does NOT reach the desired temperature.
 - Heater glow is excessively uneven.
 - Heater makes popping noises.

⚠ WARNING:

FOR YOUR SAFETY ;

DO NOT touch or move heater for at least 45 minutes after use. Allow all burner elements to cool before touching.



Check the cracks or worn sections

NOTE:

In a salt-air environment (such as near an ocean). corrosion occurs more quickly than normal. Frequently check for corroded areas and repair them promptly.

NOTE:

wait until heater is cool before covering.

MAINTENANCE/STORAGE

- Spiders and insects can nest in burner or orifices. This dangerous condition can damage heater and render it unsafe for use. Clean burner holes by using a heavy-duty pipe cleaner. Compressed air may help clear away smaller particles.
- Carbon deposits may create a fire hazard. Clean dome and burner screen with warm soapy water if any carbon deposits develop.

STORAGE:

Between uses:

- Turn the control knob to "OFF" position.
- Turn LP cylinder to "OFF" position.
- Store heater upright in an area sheltered from direct contact with inclement weather (such as rain, sleet, hail, snow, dust and debris).
- If desired, cover heater to protect exterior surfaces and to help prevent build up in air passages.

During periods of extended inactivity or when transporting;

- Turn the control knob to "OFF" position.
- Disconnect the regulator from the LP Cylinder by turning counter-clockwise and move to a secure, well-ventilated location outdoors. DO NOT store in a location that will exceed 125 degrees F.
- Store heater upright in an area sheltered from direct contact with inclement weather (such as rain, sleet, hail, snow, dust and debris).
- If desired, cover heater to protect exterior surfaces and to help prevent build up in air passages.

NOTE:

wait until heater is cool before covering.

TROUBLESHOOTING

PROBLEM	POSSIBLE CAUSE	CORRECTIVE ACTION
Pilot won't light Note: Heater operates at reduced efficiency below 40°F (5°C)	Cylinder valve is closed	Open valve
	Blockage in orifice or pilot tube	Clean or replace orifice or pilot tube
	Air in gas line	Open gas line and bleed it (pressing control knob in) for not more than 1 - 2 minutes or until you smell gas
	Low gas pressure with cylinder valve fully open	Turn cylinder valve OFF and replace cylinder
Pilot won't stay lit	Igniter fails	Use match to light pilot; obtain new igniter and replace
	Dirt built up around pilot	Clean dirt from around pilot
	Connection between gas valve and pilot assembly is loose	Tighten connection and perform leak check
Burner won't light	Thermocouple is not operating correctly	Replace thermocouple
	Propane cylinder is frosted over	Wait until the propane cylinder warms up and becomes unfrosted
	Blockage in orifice	Clear blockage
Burner flame is low	Control knob is not in ON position	Turn control knob to ON
	Gas pressure is low	Turn cylinder valve OFF and replace cylinder
	Outdoor temperature is less than 40°F and tank is less than 1/4 full	Use a full cylinder
Carbon build-up Thick black smoke	Control knob fully ON	Check burner and orifices for blockage
	Dirt or film on reflector and burner screen	Clean reflector and burner screen
	Blockage in burner	Remove blockage and clean burner inside and outside

ONE-YEAR LIMITED WARRANTY

The appliance has been manufactured under the highest standards of quality and workmanship. We warrant to the original consumer purchaser that all aspects of this product will be free of defects in material and workmanship for one (1) year from the date of purchase. A replacement for any defective part will be supplied free of charge for installation by the consumer. Defects or damage caused by the use of other than genuine parts are not covered by this warranty. This warranty shall be effective from the date of purchase as shown in the purchaser's receipt.

This warranty is valid for the original consumer purchaser only and excludes industrial, commercial or business use of the product, product damage due to shipment or failure which results from alteration, product abuse, or product misuse, whether performed by a contractor, service company, or consumer. We will not be responsible for labor charges and/or damage incurred in installation, repair or replacement, nor for incidental or consequential damage.

SHINERICH INDUSTRIAL LTD.

Addr.: 8/F, Noble Center, 1006 Fuzhong 3rd. Rd,
Futian District, Shenzhen, China



Need help?

call our toll free number at:

1-888-909-3888 or

e-mail us at:

customerservice@shinerich.us