

**C-602**

# DOUBLE LOCK GOOSENECK EXTENDER

12/29/08

GROSS LOAD CAPACITY WHEN USED AS A WEIGHT CARRYING HITCH: 20,000 LBS. TRAILER WEIGHT & 5,000 LBS. TONGUE WEIGHT.

**\*\*\*DO NOT EXCEED VEHICLE MANUFACTURER'S RECOMMENDED TOWING CAPACITY.\*\*\***

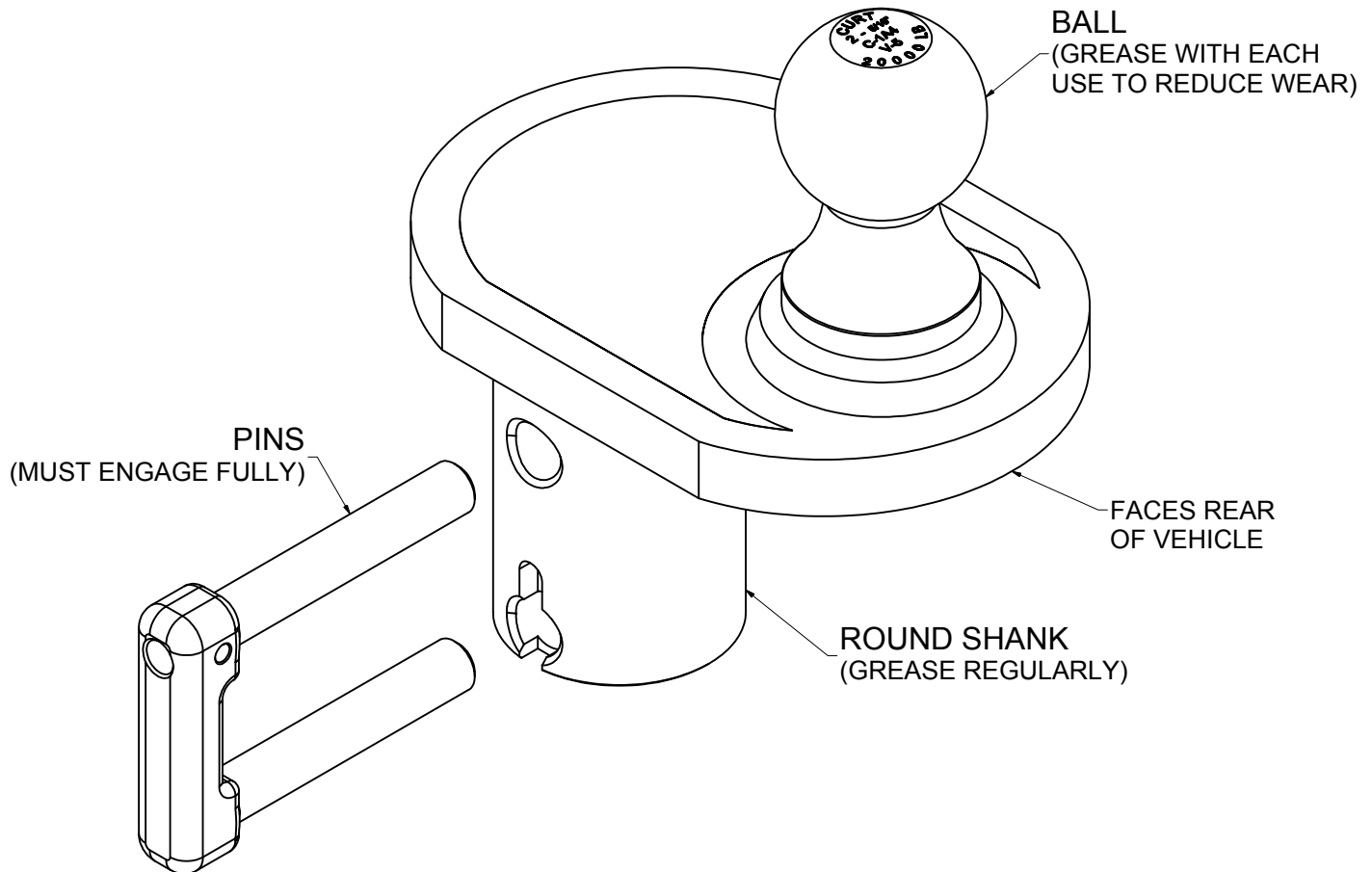

HITCH WEIGHT: 19 LBS.  
INSTALL TIME: 2 MINUTES  
INSTALL NOTES:

- NO DRILLING OR CUTTING REQUIRED
- WILL NOT FIT WITH BED LINERS

**\*\* CAN NOT BE USED WITH PLASTIC BED LINER \*\***

## **INSTALLATION STEPS**

### Application:

The Double Lock Gooseneck Extender is not to be used with plastic bed liners or other additions to the bed floor, which prohibits the gooseneck extender from being fully seated inside the Double Lock cylinder, or being engaged by the Double Lock pins. Make sure that the Extender you purchased fully seats in the gooseneck, and can be fully locked by the pins of your gooseneck hitch. **Please review tow rating information, and turning clearance warning.**

### Installation:

Disengage the double lock pins and remove ball or any other accessory. Place the round shank of the extender into the Double Lock cylinder, so that the ball is closer to the rear of the pickup than the round shank. Engage the Double Lock pins. Make sure that the pins fully engage the round shank of the extender and pass through the cylinder completely. For hitch accessories that remain in the Double lock Gooseneck for an extended period of time, Curt Mfg. recommends lightly lubricating the round shank with grease.

**PERIODICALLY CHECK THIS RECEIVER HITCH TO ENSURE THAT ALL FASTENERS ARE TIGHT AND THAT ALL STRUCTURAL COMPONENTS ARE SOUND.**

Curt Manufacturing Inc., warrants this product to be free of defects in material and/or workmanship at the time of retail purchase by the original purchaser. If the product is found to be defective, Curt Manufacturing Inc., may repair or replace the product, at their option, when the product is returned, prepaid, with proof of purchase. Alteration to, misuse of, or improper installation of this product voids the warranty. Curt Manufacturing Inc.'s liability is limited to repair or replacement of products found to be defective, and specifically excludes liability for incidental or consequential loss or damage.