

A-A

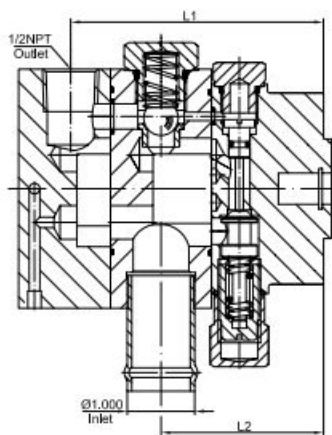

B-B

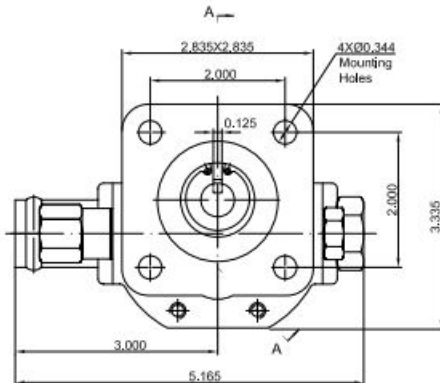
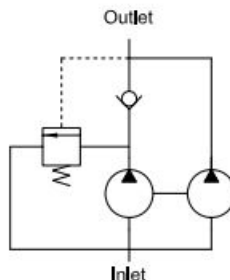

Hydraulic Schematic

Model	Flow (GPM)	Displacement (in ³ /r)		Pressure (PSI)		Speed (RPM)	Dimension (in)		
		HI Pre	Low Pre	Unload	Work		L	L1	L2
CBNA-4.2/1.0	5	0.0701	0.2468	Range: 400~900	3000	3600	6.21	3.94	2.52
CBNA-6.3/1.0	7	0.0701	0.3880				6.21	3.94	2.52
CBNA-6.3/2.1	8	0.1324	0.3880				6.07	3.75	2.41
CBNA-6.3/3.0	8.5	0.1940	0.3880				6.21	3.75	2.41
CBNA-6.3/3.6	9	0.2239	0.3880				6.27	3.90	2.41
CBNA-8.8/1.6	10	0.1056	0.5387				6.37	4.08	2.74
CBNA-8.8/2.1	10.2	0.1324	0.5387				6.40	4.08	2.74
CBNA-8.8/3.0	10.5	0.1940	0.5387				6.54	4.08	2.74
CBNA-8.8/3.6	11	0.2239	0.5387				6.61	4.23	2.74
CBNA-8.8/4.2	11.5	0.2468	0.5387				6.70	4.23	2.74
CBNA-10.9/2.1	12	0.1324	0.6705				6.70	4.37	2.03
CBNA-10.9/3.0	12.5	0.1940	0.6705				6.83	4.37	2.03
CBNA-10.9/3.6	13	0.2239	0.6705				6.90	4.53	2.03
CBNA-10.9/4.2	13.5	0.2468	0.6705				6.99	4.53	2.03
CBNA-13/2.1	13.5	0.1324	0.7944				6.97	4.65	3.31
CBNA-13/3.0	15.4	0.1940	0.7944				7.11	4.65	3.31
CBNA-13/3.6	15.9	0.2239	0.7944	7.11	4.65	3.31			
CBNA-13/4.2	16.4	0.2468	0.7944	7.27	4.80	3.31			