

零部件图册

PARTS CATALOG

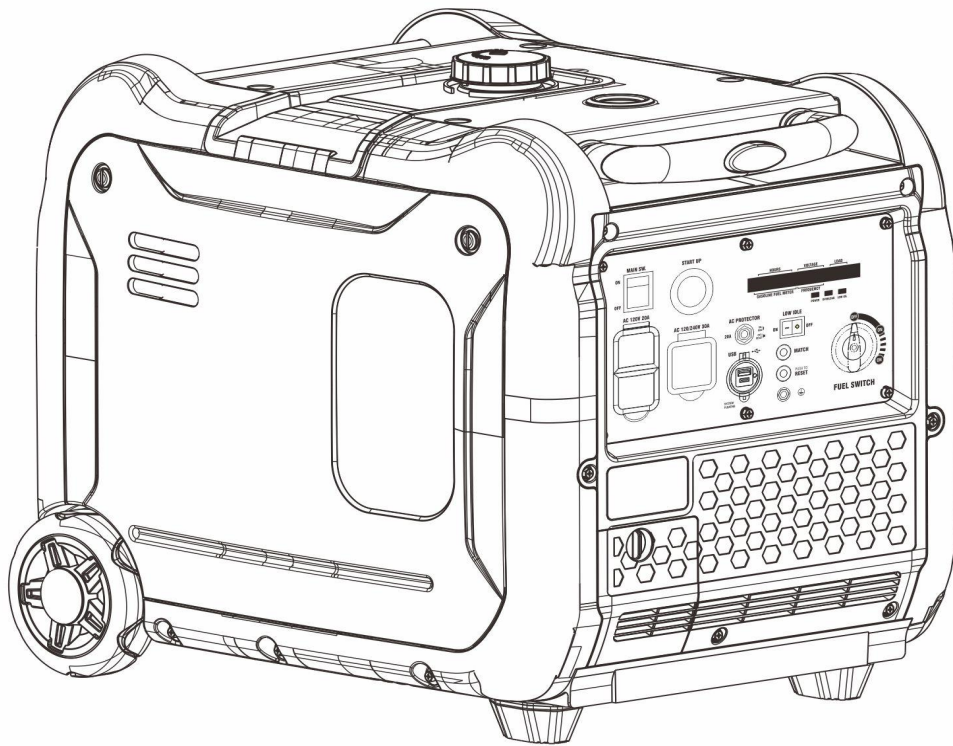

GM5500i

Inverter Generator

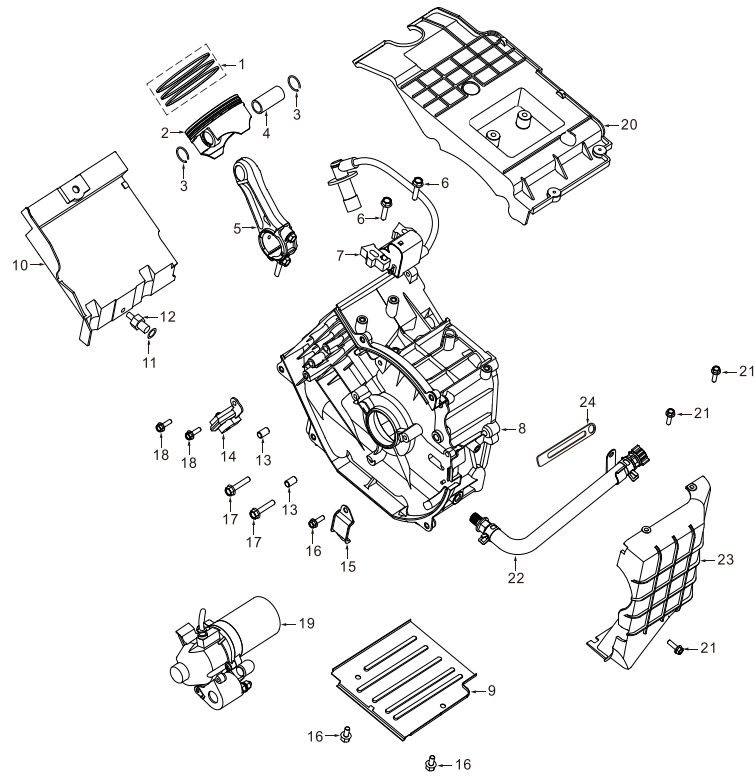

曲轴箱 (Crankcase)

序号 No.	零部件图号 Part No.	零部件名称	Description	数量 Quantity
1	0210.180.X01V.00.00	活塞环组件	Piston ring ass.	1
2	0200.F80.001V.00.00	活塞	Piston	1
3	0230.168.001V.00.00	活塞环卡圈	Clip,Piston pin	2
4	0220.F80.001V.00.00	活塞销	Piston pin	1
5	0190.F80.001V.00.00	连杆组件	Connecting rod assembly	1
6	5787.06025.00.01	螺栓 M6×25	Blot	2
7	2100.F80.001V.00.00	高压包	High pressure bag	1
8	1000.F80.0011.00.00	曲轴箱体	Crankcase body	1
9	3340.F80.001V.00.00	发动机底板	Engine floor	1
10	6985.F80.0020.00.00	缸头罩	Cylinder head cover	1

11	1260.168.R001V.66.00	放油螺栓垫片 $\phi 10$	Gasket for oil drain bolt	2
12	1250.F80.0011.00.20	放油螺栓 M10 \times 1.25 \times 15--M6	Oil drain bolt	2
13	3170.168.R001V.00.00	定位销-A型 8 \times 14	Set pin	2
14	1521.F80.001V.00.00	触发器	Trigger	1
15	2090.F80.001V.00.00	压线板	Crimping board	1
16	5787.06014.00.01	带盘螺栓 M6 \times 14	Blot	3
17	5789.06028.00.01	带盘螺栓 M6 \times 28	Blot	2
18	5789.05016.00.07	带盘螺栓 M5 \times 16	Blot	2
19	2070.F80.A01V.00.00	起动电机	Starting motor	1
20	8654.F80.0011.00.00	箱体罩	Case cover	1
21	5787.06018.00.01	带盘螺栓 M6 \times 18	Blot	3
22	2330.F80.001V.00.00	放油管组合	Oil drain pipe combination	1
23	2783.F80.0020.00.00	启动电机罩	Starting motor cover	1
24	1220.528.R0010.00.00	压线板	Tension disc	1

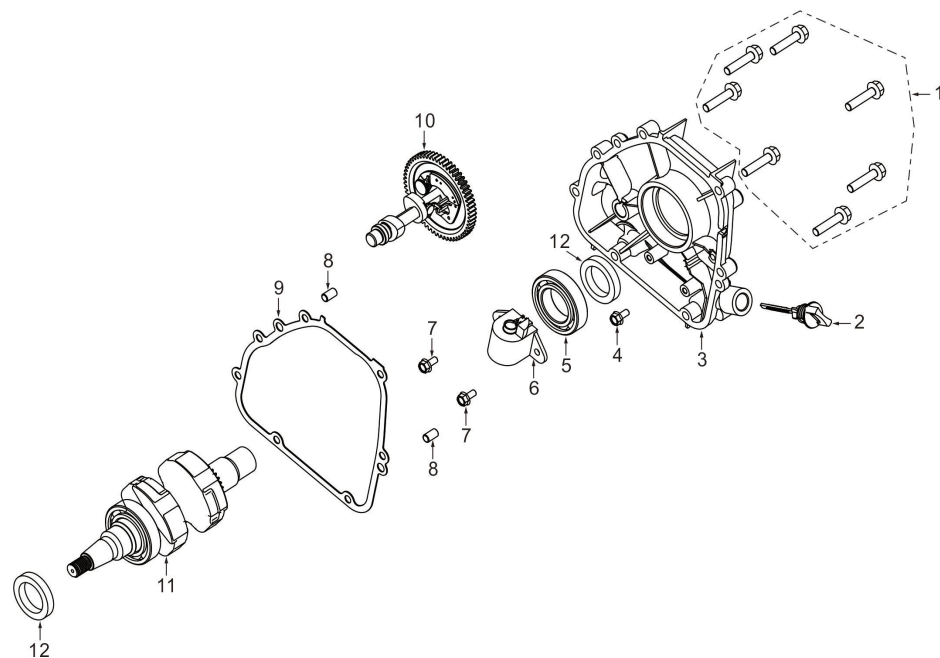

曲轴箱盖 (Crankcase cover)

序号 No.	零部件图号 Part No.	零部件名称	Description	数量 Quantity
1	5787.08035.00.01	带盘螺栓 M8×35	Blot	7
2	1230.F80.001V.00.00	机油尺组件	Oil gauge ass.	1
3	1010.F80.0031.00.00	曲轴箱盖	Crankcase cover	1
4	5789.06010.00.01	带盘螺栓 M6×10	Blot	1
5	0270.173.005V.00.00	轴承6206	Ball bearing	1
6	1020.148.0011.00.00	机油报警器	Warning device	1
7	5787.06014.00.01	带盘螺栓 M6×14	Blot	2
8	3170.168.R001V.00.00	定位销-A型 8×14	Set pin	2
9	3040.F80.0011.00.00	曲轴箱密封垫	Gasket, Crankcase	1
10	1040.F80.0010.60.00	凸轮轴	Camshaft ass.	1
11	0180.F80.0030.00.00	曲轴组件	Crankshaft ass.	1
12	3150.173.001V.00.00	油封 30×46×8	Oil seal	2

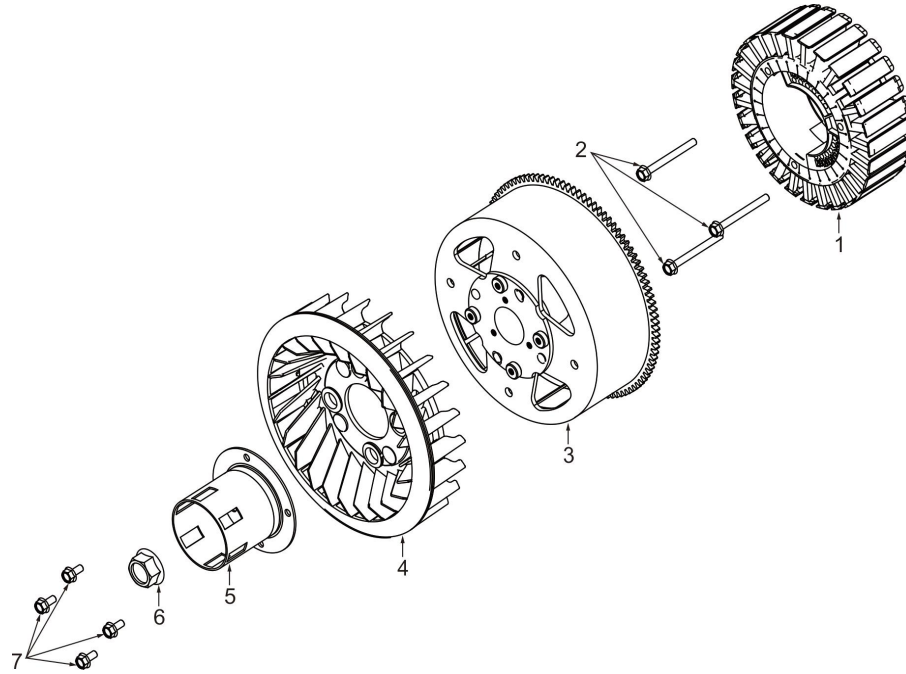

电机组件 (Motor assembly)

序号 No.	零部件图号 Part No.	零部件名称	Description	数量 Quantity
1	4000.528.0030.00.02	电机定子	Motor stator	1
2	5787.06065.00.01	带盘螺栓 M6×65	Blot	3
3	4000.528.001V.00.01	电机转子	Motor rotor	1
4	2030.528.0010.63.11	飞轮风扇	Flywheel fan	1
5	2020.F80.002V.00.00	启动套	Starting sleeve	1
6	6177.14000.06.01	带盘螺母 M14×1.5	Nut	1
7	5787.06014.00.01	带盘螺栓 M6×14	Blot	4

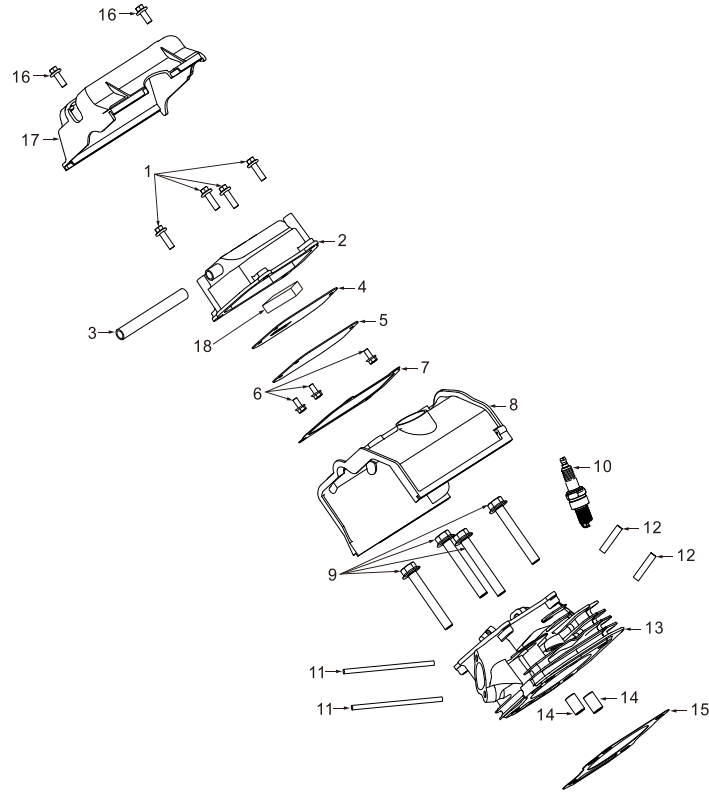

缸头组件 (Cylinder head parts)

序号 No.	零部件图号 Part No.	零部件名称	Description	数量 Quantity
1	5787.06025.00.01	带盘螺栓 M6×25	Blot	4
2	0001.F80.001V.00.01	缸头盖	Cylinder head cover	1
3	2370.F80.001V.00.00	废气管	Exhaust pipe	1
4	7061.F80.001V.00.00	呼吸阀板组合	Breathing valve plate assembly	1
5	7061.F80.002V.00.00	呼吸阀垫	Breathing valve pad	1
6	5789.05010.00.07	螺栓 M5×10	Blot	1
7	3000.F80.001V.00.00	缸头盖垫	Cylinder head cover pad	1
8	2190.F80.0011.00.00	缸体导风罩	Cylinder guide hood	1
9	5787.10075.05.10	带盘螺栓 M10×1.25×75	Blot	4
10	2160.168.008V.00.00	火花塞	Spark plug	1

11	0900.06102.00.01	台阶双头螺栓 6×102	Blot	2
12	R0900.08032.00.01	双头螺栓 8×32	Blot	2
13	0010.F80.001V.00.00	气缸头	Cylinder head	1
14	3170.188.002V.00.00	定位销 12×20	Set pin	2
15	3020.F80.0020.00.00	缸头垫	Gasket, Cylinder head	1
16	5787.06018.00.01	带盘螺栓 M6×18	Blot	2
17	2781.F80.0010.00.00	缸头盖罩	Cylinder head cover	1
18	7080.165.001V.00.00	燃油滤网	Fuel filter	1

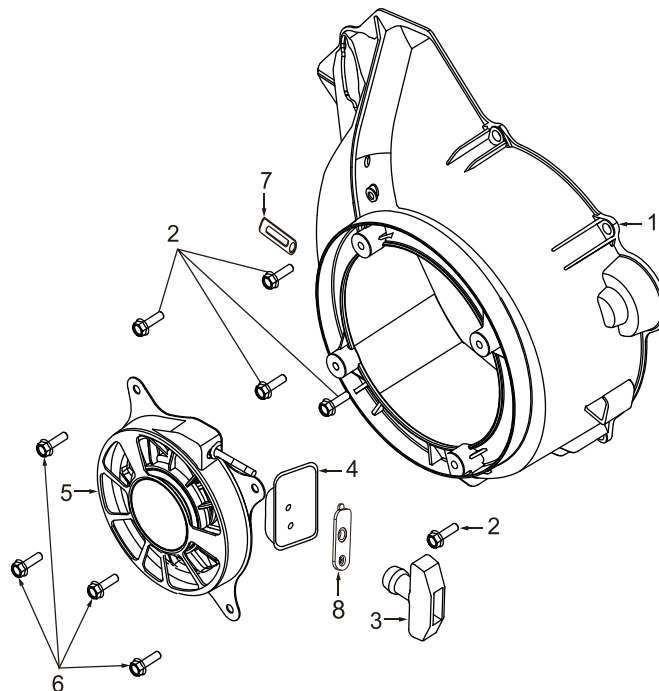

单机起动器 (Engine Starter)

序号 No.	零部件图号 Part No.	零部件名称	Description	数量 Quantity
1	2000.F80.0011.00.01	起动大罩	Starting hood	1
2	5787.06018.00.01	带盘螺栓 M6×18	Blot	5
3	2000.T70.001V.00.03	起动手柄	Starting handle	1
4	2186.T48.001V.00.00	拉手盖板	Handle cover	1
5	2000.T70.0020.00.02	拉盘	Pull the plate	1
6	5787.06014.00.01	带盘螺栓 M6×14	Blot	4
7	1220.528.R0020.00.00	压线板	Tension disc	1
8	7495.528.0020.00.00	拉索装饰盖板	Cable trim cover plate	1

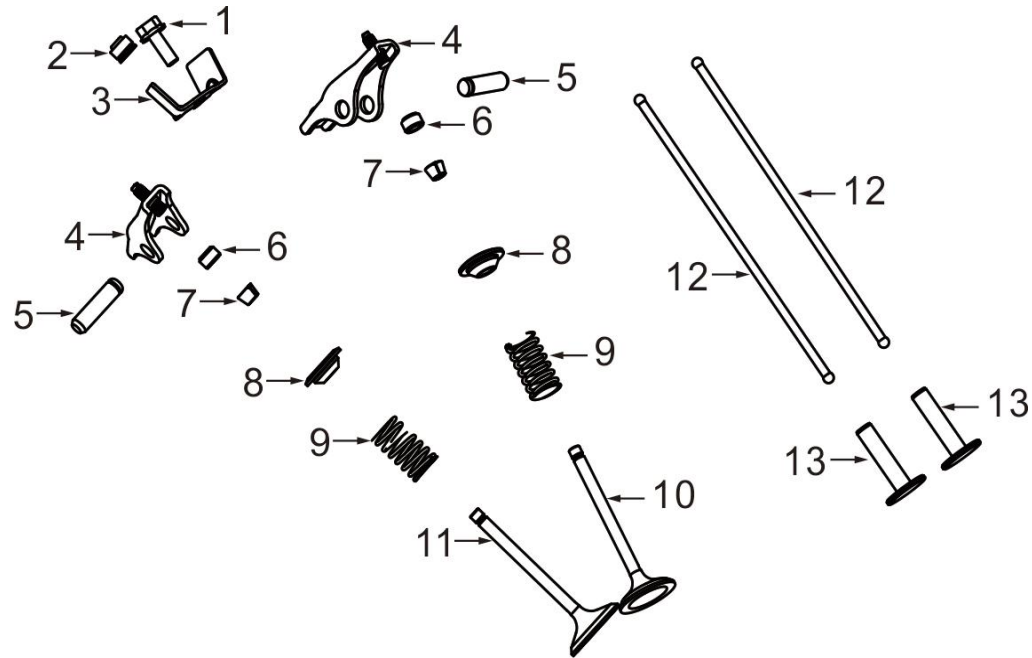

配气 (Air distribution)

序号 No.	零部件图号 Part No.	零部件名称	Description	数量 Quantity
1	5787.06014.00.01	带盘螺栓 M6×14	Blot	1
2	0085.165.001V.00.00	挡油罩	Oil seal, Intake valve	1
3	0107.F70.020V.00.00	摇臂轴挡块	Rocker shaft stop	1
4	0100.F80.001V.00.00	摇臂	Rocker ass.	2
5	0105.K92.001V.00.00	摇臂轴	Rocker shaft	2
6	0090.168.001V.00.00	气门顶帽	Valve top cap	2
7	1120.165.0020.00.00	气门锁夹	Valve collet	2
8	0060.165.0020.00.00	气门弹簧座	Valve spring seat	2
9	0040.F80.001V.00.00	气门弹簧	Valve spring	2
10	0030.F80.001V.00.00	排气门	Exhaust valve	1
11	0020.F80.001V.00.00	进气门	Intake valve	1
12	0160.F80.001V.00.00	推杆	Pusher	2
13	1030.F68.001V.00.00	挺柱	Tappet	2

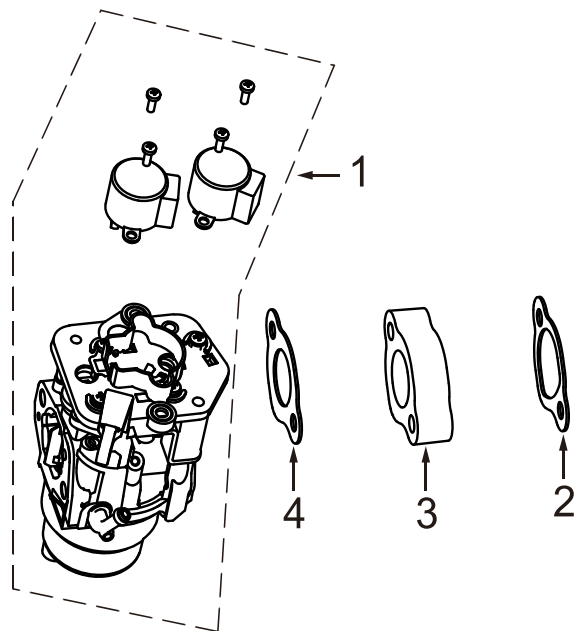

化油器部件 (Carburetor parts)

序号 No.	零部件图号 Part No.	零部件名称	Description	数量 Quantity
1	2260.F80.0070.00.00	化油器组件	Carburetor ass.	1
2	3060.F80.001V.00.00	进气口垫片	Gasket, inlet port	1
3	2300.F80.001V.00.00	化油器接块	Carburetor block	1
4	3080.F80.001V.00.00	化油器垫片	Gasket, carburetor	1

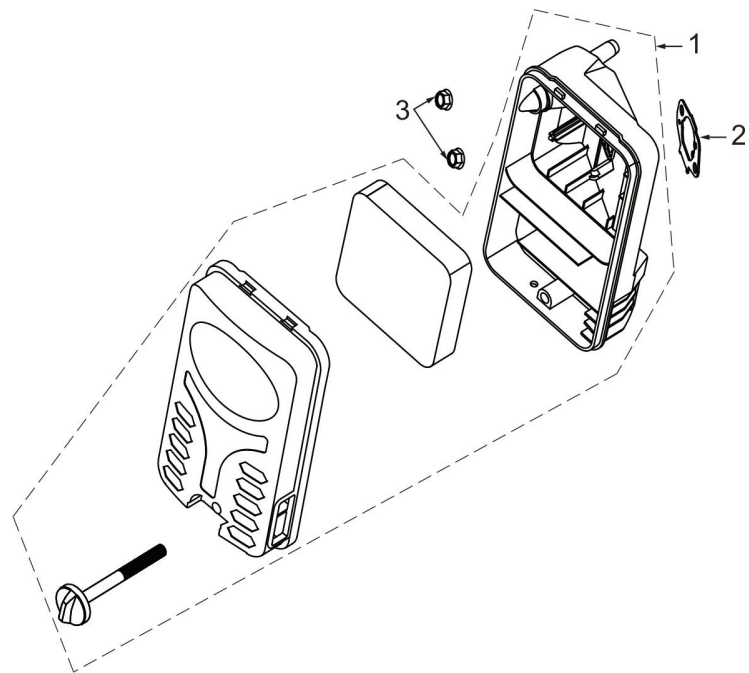

空滤器 (Air cleaner)

序号 No.	零部件图号 Part No.	零部件名称	Description	数量 Quantity
1	2280.F80.0020.00.00	空滤器组件	Air cleaner ass.	1
2	3095.168.001V.00.00	空滤器纸垫	Air filter paper pad	1
3	6177.06000.00.01	带盘防松螺母 M6	Nut	2

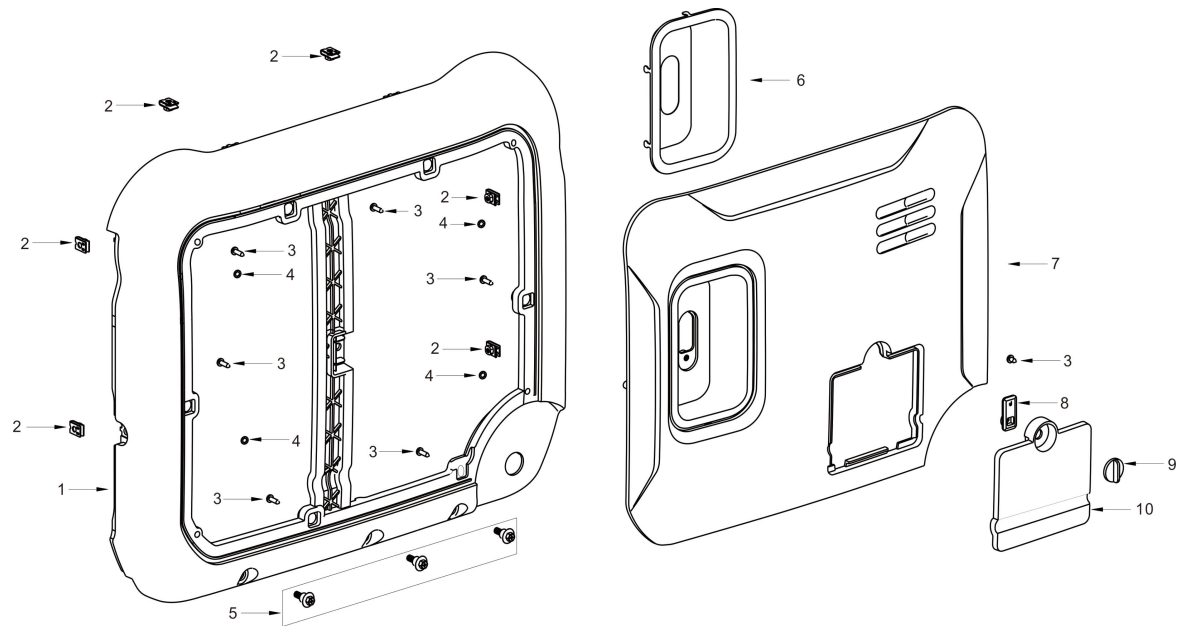

右外壳 (Right housing)

序号 No.	零部件图号 Part No.	零部件名称	Description	数量 Quantity
1	2222.528.001V.00.00	右外壳	Right shell	1
2	6178.05000.01.04	夹片螺母 M5	Nut	6
3	0845.42013.00.01	自攻螺钉 M4.2×13	Self tapping screw	7
4	5598.467.001V.00.00	梅花孔挡圈	Plum blossom hole retaining ring	4
5	4789.467.001V.00.00	台阶螺栓 M6×16.5	Bolt	3
6	7495.528.001V.00.00	起动手柄装饰盖	Decorative cover of starting handle	1
7	5596.528.0010.P4.00	右侧外观盖板	Right appearance cover	1
8	6542.528.001V.00.00	限位挡块	Limit stop	1
9	6378.528.001V.00.00	护门旋钮	Door knob	1
10	1142.528.0010.P4.00	加放机油维护门	Oil filling and draining maintenance door	1

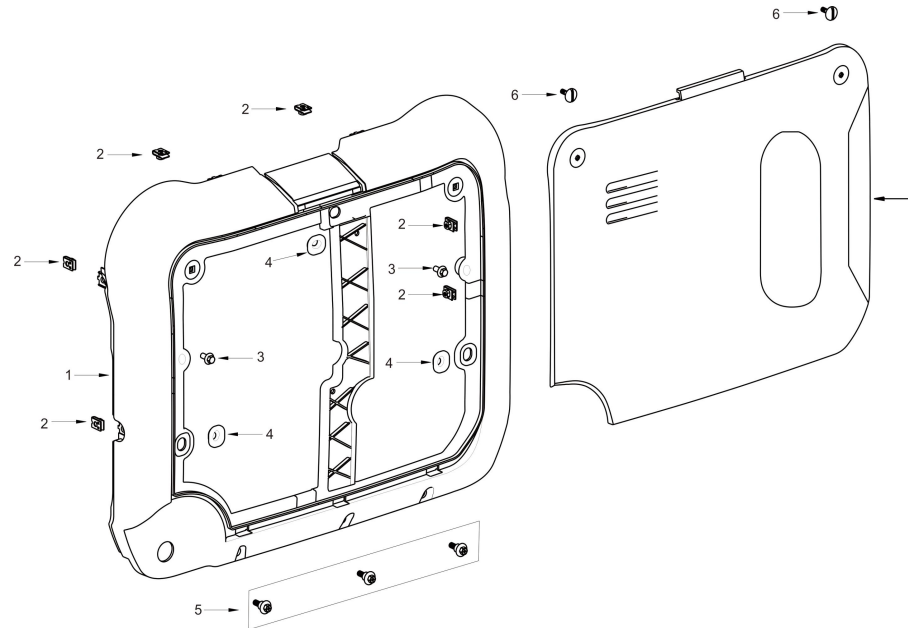

左外壳 (Left housing)

序号 No.	零部件图号 Part No.	零部件名称	Description	数量 Quantity
1	2220.528.001V.00.00	左外壳	Left housing	1
2	6178.05000.01.04	夹片螺母 M5	Nut	6
3	5787.06012.00.01	带盘螺栓 M6×12	Bolt	2
4	5522.467.002V.00.00	油箱支撑胶套B	Oil tank support rubber sleeve B	3
5	4789.467.001V.00.00	台阶螺栓 M6×16.5	Bolt	3
6	5424.528.001V.00.00	一字槽半圆头螺钉 M5×16	Slotted half round head screw	2
7	5596.528.0020.P4.00	左侧外观盖板	Left appearance cover	1

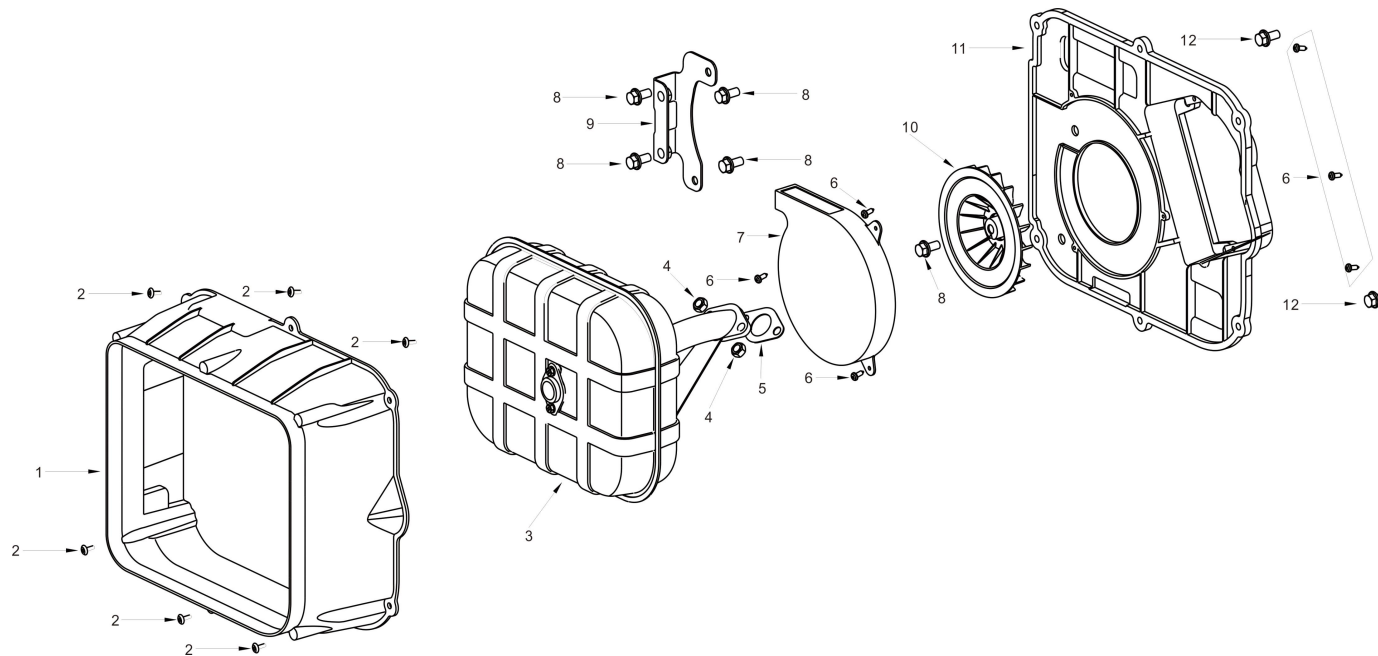

消声器 (Muffler parts)

序号 No.	零部件图号 Part No.	零部件名称	Description	数量 Quantity
1	2402.528.001V.00.00	消声器外罩	Muffler cover	1
2	5787.05016.00.01	带盘螺栓 M5×16	Bolt	6
3	2400.528.001V.00.00	消声器组件	Muffler assembly	1
4	6170.08000.00.01	六角螺母 M8	Hexagon nut	2
5	3100.188.004V.00.00	消声器密封垫	Muffler gasket	1
6	0845.42013.00.07	自攻螺钉 M4.2×13	Self tapping screw	6
7	2030.528.0011.63.12	风扇罩	Fan hood	1
8	5787.08016.00.01	带盘螺栓 M8×16	Bolt	5
9	1689.528.001V.00.00	消声器安装支架	Muffler mounting bracket	1
10	2030.F80.001V.00.00	风扇	Fan	1
11	9757.528.001V.00.00	消声器外罩隔板	The muffler housing clapboard	1
12	5787.06016.00.01	带盘螺栓 M6×16	Bolt	2

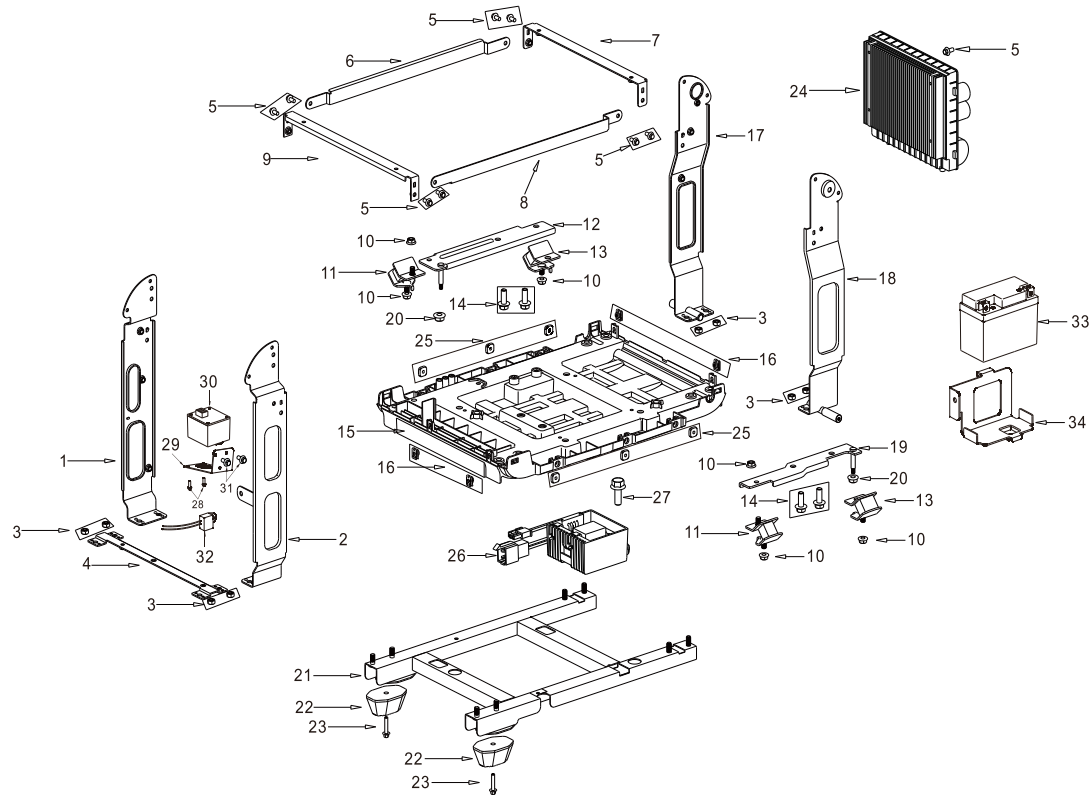

机架 (Frame)

序号 No.	零部件图号 Part No.	零部件名称	Description	数量 Quantity
1	4863.528.001V.00.00	左支架1	Left bracket 1	1
2	4863.528.0051.00.00	右支架1	Right bracket 1	1
3	6170.08000.00.07	六角螺母 M8	Nut	8
4	9727.528.001V.00.00	前横杆	Front cross bar	1
5	5787.06012.00.01	带盘螺栓 M6×12	Bolt	9
6	2999.528.001V.00.00	左横档	Left rail	1
7	7174.528.002V.00.00	油箱后支架	Fuel tank rear bracket	1
8	2999.528.002V.00.00	右横档	Right rail	1
9	7174.528.001V.00.00	油箱前支架	Fuel tank front bracket	1

10	6177.08000.00.01	带盘螺母 M8	Nut	6
11	3360.487.001V.00.00	减震垫1 (高30)	Damping pad 1	2
12	3340.528.001V.00.00	动力固定底板1	Power fixed base plate 1	1
13	3360.528.001V.00.00	减震垫1 (斜45°)	Damping pad 1	2
14	5787.10025.05.01	带盘螺栓 M10×25	Bolt	4
15	3340.528.003V.00.00	底板	Floor	1
16	6178.05000.01.04	夹片螺母 M5	Clip nut	4
17	4863.528.002V.00.00	左支架2	Left bracket 2	1
18	4863.528.004V.00.00	右支架2	Right bracket 2	1
19	3340.528.002V.00.00	动力固定底板2	Power fixed base plate 2	1
20	6177.06000.00.01	带盘螺母 M6	Nut	2
21	6353.528.001V.00.00	机架底支架	Frame bottom bracket	1
22	3350.528.001V.00.00	减震座 80×53×33.5	Shock absorber seat	2
23	5787.06025.00.01	带盘螺栓 M6×25	Bolt	2
24	2470.528.0110.00.00	逆变器	Inverter	1
25	5926.467.001V.00.00	方螺母 M6	Square nut	6
26	6854.528.0021.00.00	调压整流器	Voltage regulating rectifier	1
27	5787.06016.00.01	带盘螺栓 M6×16	Bolt	1
28	6111.469.0020.00.00	螺栓 M3*10	Bolt	2
29	5528.460.0011.00.00	CO报警器支架	CO alarm bracket	1
30	5528.460.0011.00.00	CO报警器	CO alarm	1
31	6111.469.0010.00.00	螺栓 M6*10	Bolt	2
32	3524.460.0050.00.00	防篡改器	Tamper-proof device	1
33	2461.188.001V.00.00	电池	Battery	1
34	4885.528.001V.00.00	电瓶支架	Battery holder	1

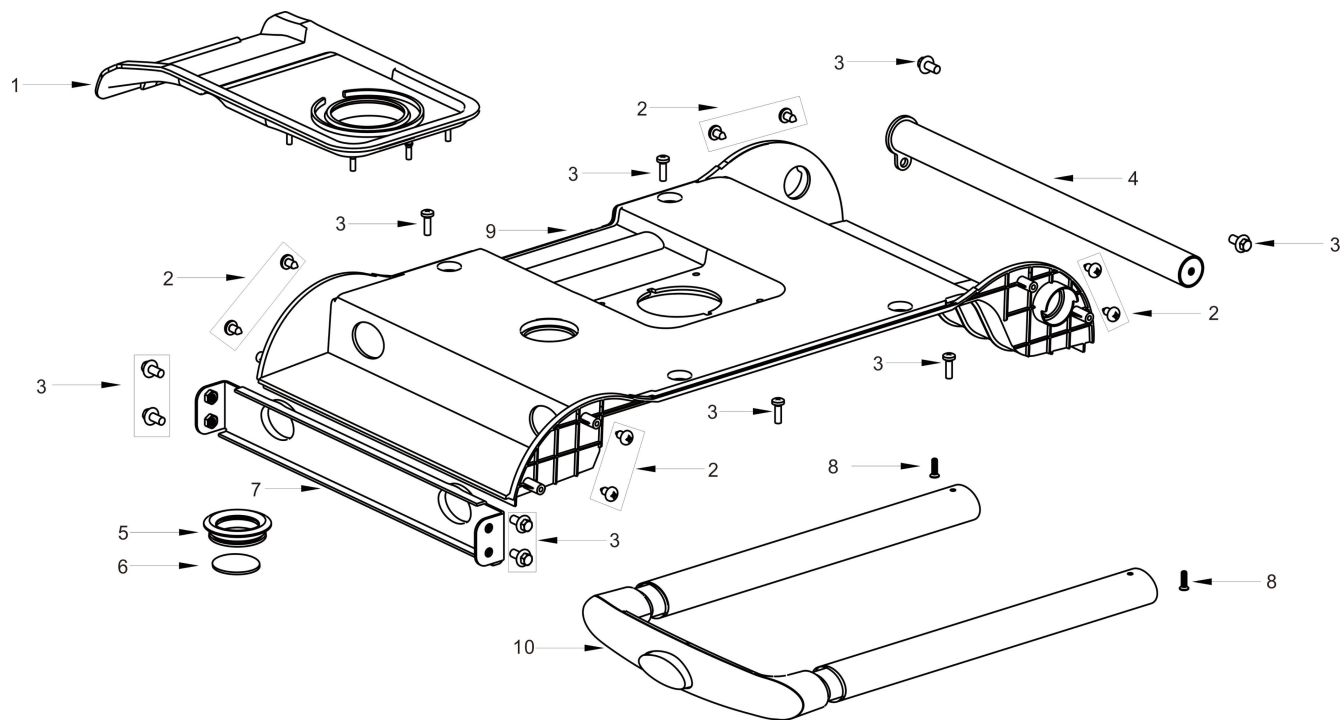

拉杆外壳 (Pull rod/Housing)

序号 No.	零部件图号 Part No.	零部件名称	Description	数量 Quantity
1	3200.528.001V.00.03	注油口胶套	Rubber sleeve of oil filling port	1
2	0845.42016.00.07	自攻螺钉 M4.2×16	Self tapping screw	8
3	5787.06012.00.01	带盘螺栓 M6×12	Bolt	10
4	3330.528.0010.00.00	扶手	Handrail	1
5	9988.528.001V.00.00	油位窗胶套	Oil level window rubber sleeve	1
6	8787.528.001V.00.00	油位窗玻璃	Oil level window glass	1
7	9577.528.001V.00.00	抽拉把手支撑架	Pull handle support frame	1
8	0845.35095.00.07	自攻螺钉 M3.5×9.5	Self tapping screw	2
9	9674.528.001V.00.00	上外壳	Upper shell	1
10	9874.528.0020.00.00	抽拉把手组件	Pull handle assembly	1

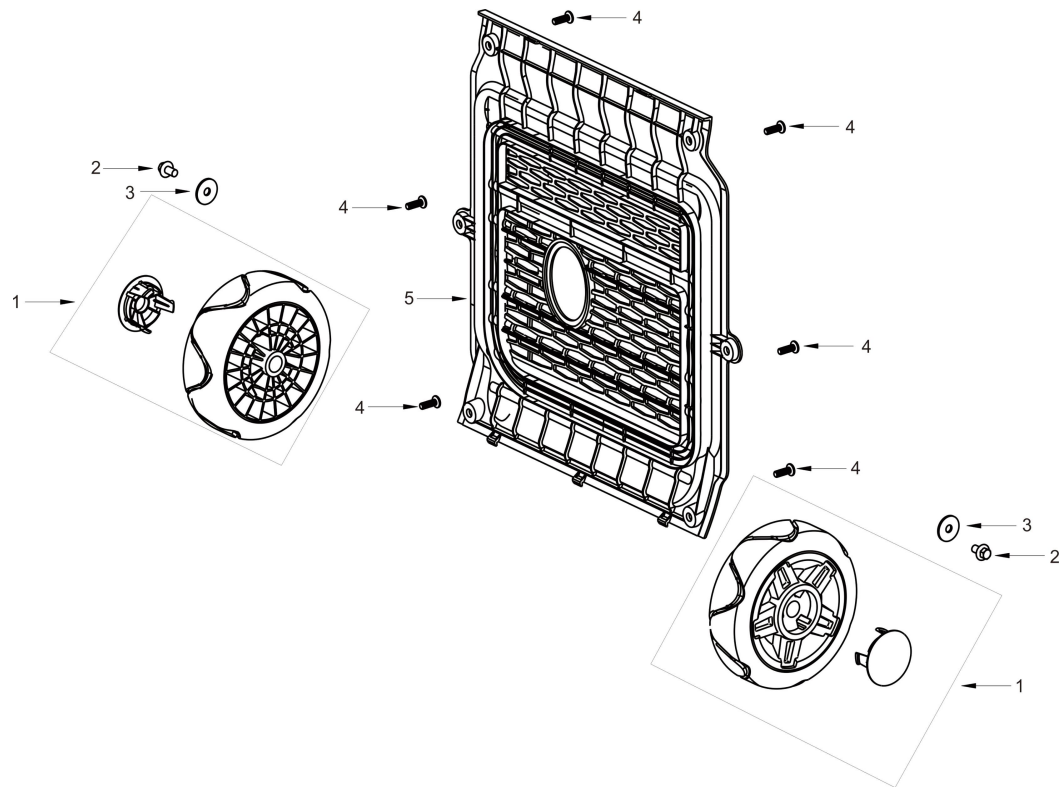

尾罩 (Tail cover)

序号 No.	零部件图号 Part No.	零部件名称	Description	数量 Quantity
1	7390.528.001V.00.00	前轮	Front wheel	2
2	5787.06012.00.01	带盘螺栓 M6×12	Bolt	2
3	4100.460.R001V.20.00	非标平垫 Φ6×Φ25×1.5	Non standard flat pad	2
4	0818.05016.00.07	十字大盘头螺钉 5×6	Cross large pan head screw	6
5	2435.528.0011.00.00	消声器边罩	Muffler side cover	1

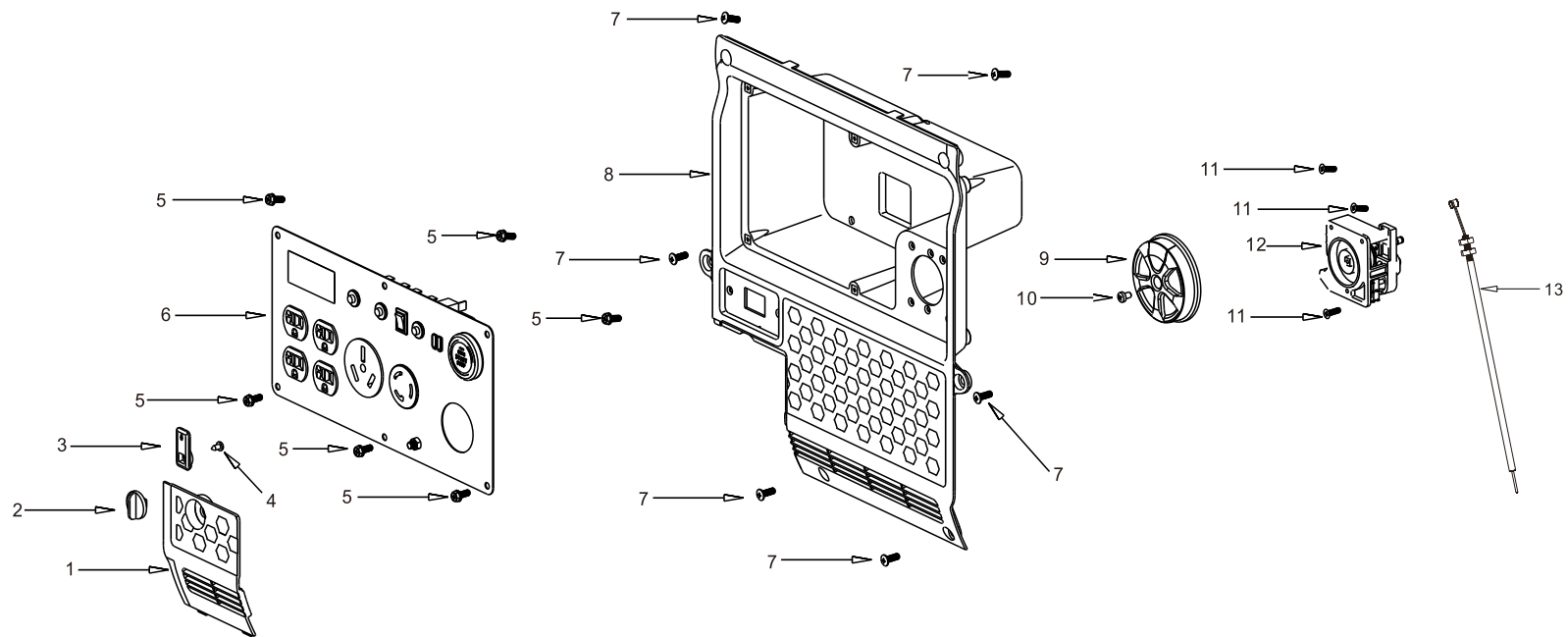

面板 (Panel)

序号 No.	零部件图号 Part No.	零部件名称	Description	数量 Quantity
1	8748.528.001V.00.00	电瓶护门	Battery door	1
2	6378.528.001V.00.00	护门旋钮	Knob	1
3	6542.528.001V.00.00	限位挡块	Stop block	1
4	0845.42010.00.07	自攻螺钉 M4.2×10	Self tapping screw	1
5	0818.05010.00.07	十字盘头螺钉 5×10	Cross pan head screw	6
6	3370.528.0151.00.99	控制面板组合	Control panel combination	1
7	0818.05016.00.07	十字大盘头螺钉 5×16	Cross large pan head screw	6
8	6655.528.001V.00.00	面板座	Panel seat	1
9	2141.528.0010.00.00	四合一开关手柄	Three in one switch handle	1
10	0818.04014.00.01	十字盘头螺钉 4×14	Cross pan head screw	1
11	0819.04212.00.01	十字沉头自攻螺钉 4.2×12	Self tapping screw	3
12	2140.528.0010.00.00	四合一开关	Three in one switch	1
13	2140.467.011V.00.03	拉索组合	Lasso combination	1

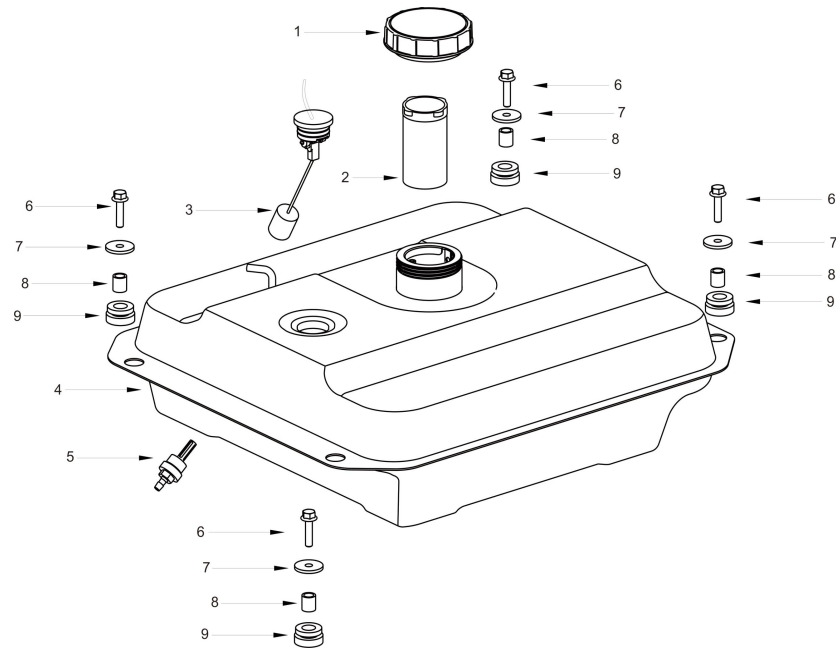

燃油箱部件 (Fuel tank components)

序号 No.	零部件图号 Part No.	零部件名称	Description	数量 Quantity
1	3200.487.C01V.04.01	油箱盖	Fuel tank cap	1
2	3200.168.075V.00.05	燃油滤网	Fuel filter screen	1
3	3200.528.0010.00.06	圆形电子油标	Circular electronic oil mark	1
4	3200.528.001V.00.00	油箱	Tank	1
5	3206.168.R001V.00.00	油箱出油嘴	Fuel tank outlet nozzle	1
6	5787.06025.00.01	带盘螺栓 M6×25	Bolt	4
7	460.4100.R001V.20.00	非标平垫 Φ6×Φ25×1.5	Non standard flat pad	4
8	3213.460.001V.00.00	油箱衬套 Φ8.6×Φ12×Φ12.2	Tank bushing	4
9	3217.460.001V.00.00	油箱安装胶套	Oil tank mounting rubber sleeve	4