

Zhaga Book 18, Microwave Motion Sensor + Daylight Priority

Feature :

1. 12VDC input, 0-10V dimmable.
2. Daylight Priority Function.
3. Optional detection range, holdtime ,daylight threshold, Stand-by period and Stand-by dimming level.
4. Remote Control.
5. 5 Year Warranty.



Components

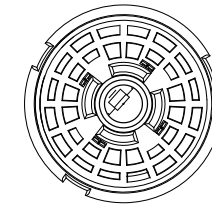
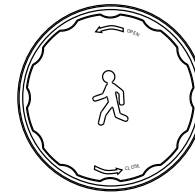
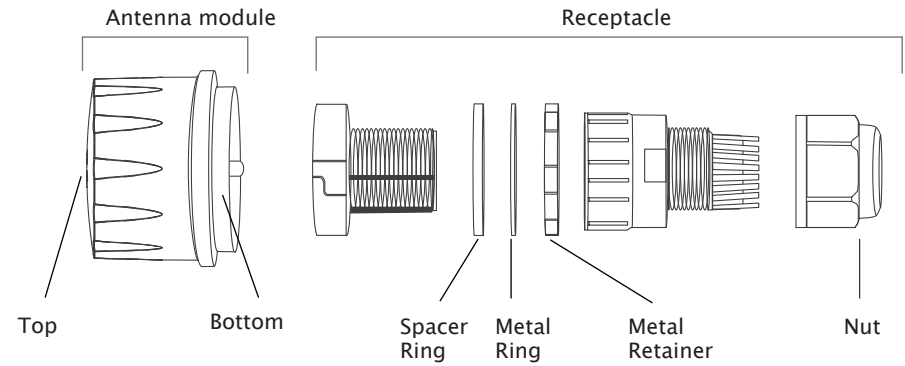
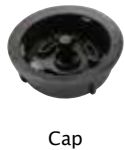

Mount A, refers to the mount for the biggest pin.

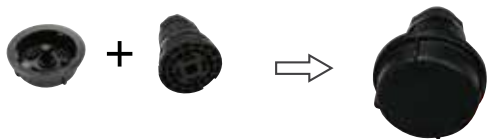
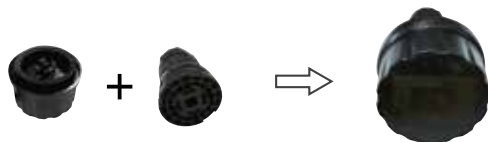
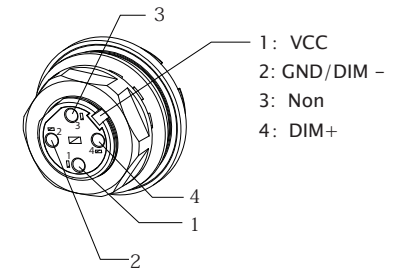
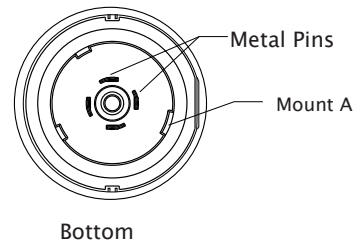

Size (based on MM)

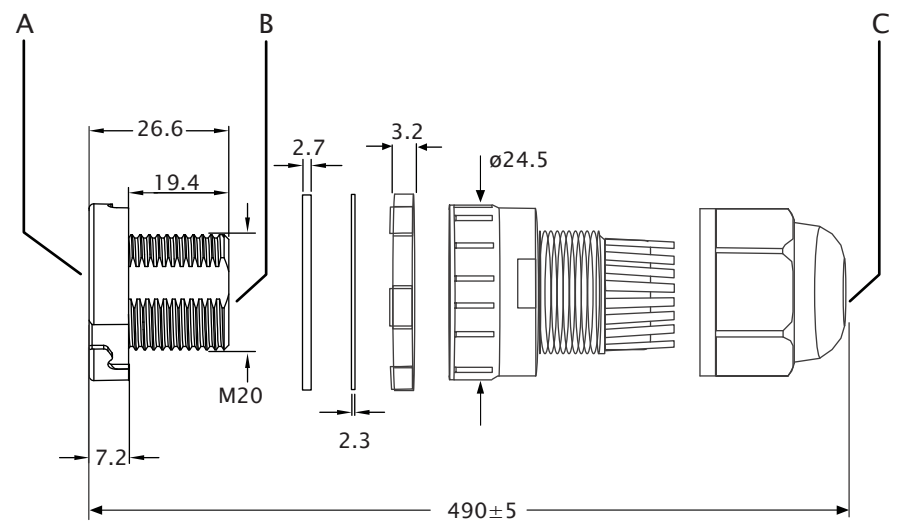
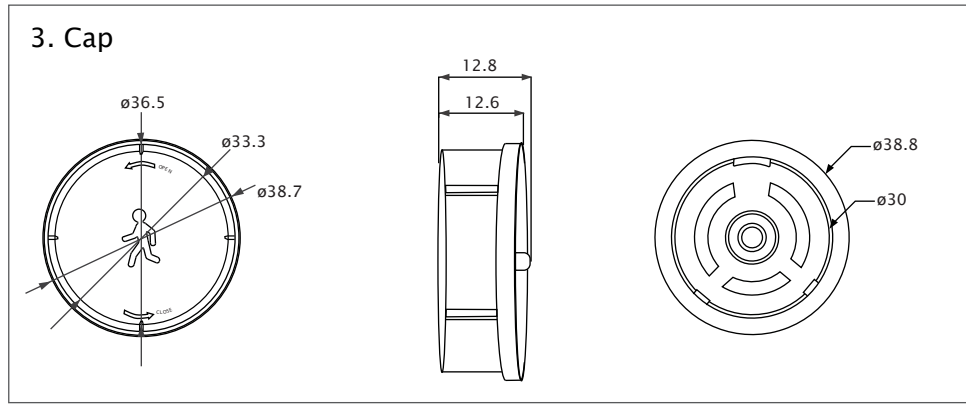
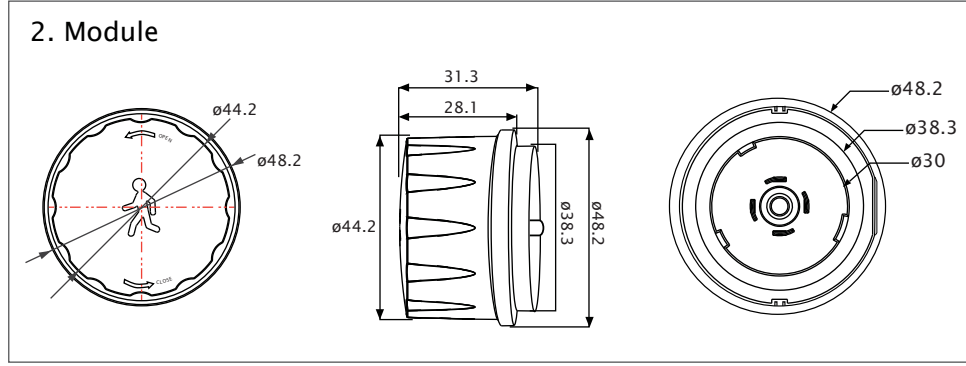
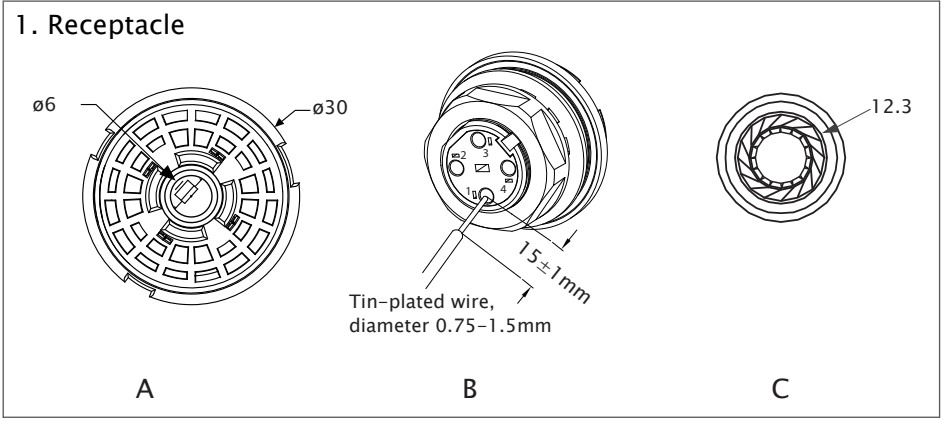

Wiring diagram

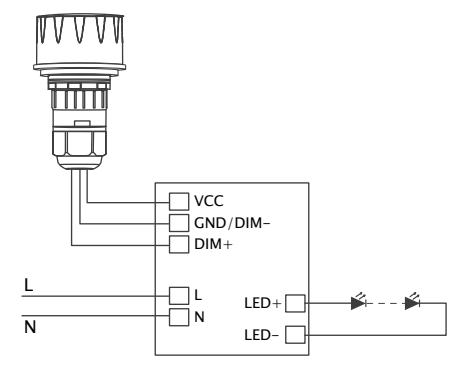

- 1: VCC
- 2: GND/DIM -
- 3: Non
- 4: DIM+.

Installation Method

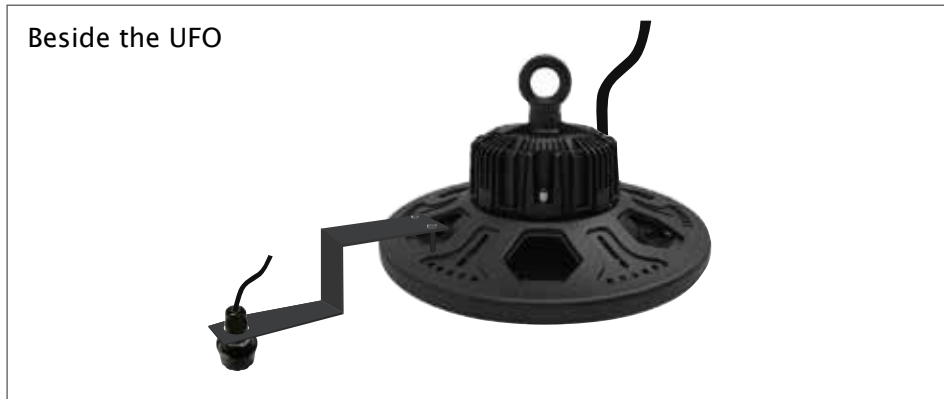
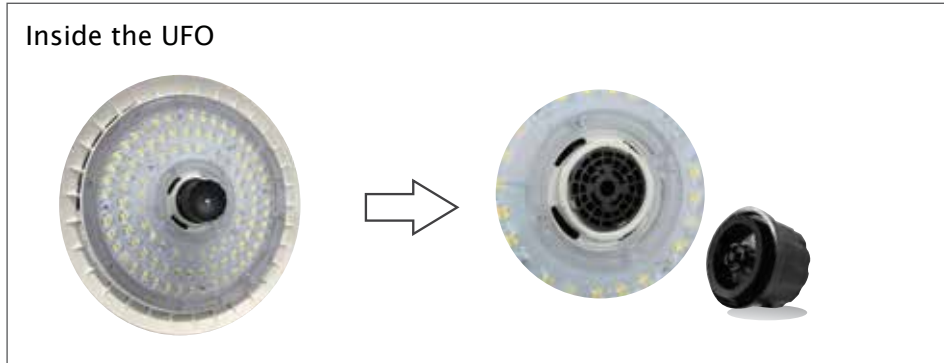

Pin to Mount

Specification

| | | |
|----------------------------|--|--|
| Input | Voltage | 10.5-15V DC (Current Required > 30mA) |
| | Standby Consumption | < 30mA (Power Consumption) |
| Output | Dim Output | DIM 1-10V |
| Daylight Priority Function | | Detection area: 120Lux/80Lux/50Lux/30Lux Stand-by period: +∞ Stand-by dimming level: 10%/20%/30% |
| Sensor Parameters | Detection Area | 25%/50%/75%/100% |
| | Holdtime | 5s/30s/1min/3min/5min/10min/20min/30min |
| | Daylight Threshold | 2Lux/10Lux/30Lux/50Lux/80Lux/120Lux/Disable |
| | Stand-by Period | 0s/10s/30s/1min/5min/10min/30min/60min+∞ |
| | Stand-by Dimming Level | 10%/20%/30%/50% |
| | Microwave Frequency | 5.8GHz±75MHz |
| | Microwave Power | < 0.3mW |
| | Mounting Height | ≤ 12m/39.36ft (Ceiling Mounted) |
| | Detection Range | Max, ∅16m/52.49ft (Ceiling Mounted) |
| Others | Temperature | -20°C~+60°C |
| | IP Grade | IP65 |
| | Warranty | 5 Years |
| Remark | Factory Default Setting: Detection area 100%/ Hold time 5s/ Daylight threshold Disable/ Stand-by period 0s/Stand-by dimming level 10%. | |

Detection coverage

Typical installation height 8-12m.

This figure indicates the maximum distance at the highest mounting height with 100% sensitivity.

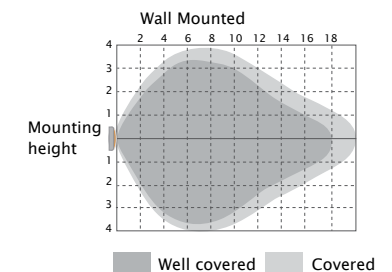
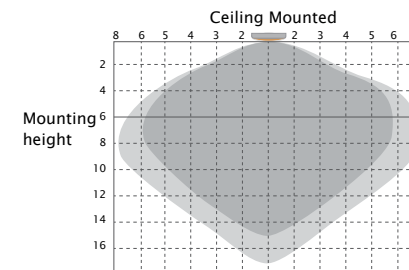

Daylight Priority

Dusk/Dawn sensor:

Dual-PD technology brings a fully automatic dusk/dawn sensor which can tell the difference between natural light and LED light, to ensure the light will be off when needed.

Precondition of Daylight priority:

1. Daylight threshold is on 30Lux/50Lux/80Lux/120Lux;
2. Standby period is $+\infty$;
3. Standby dimming level is on 10%/20%/30%.

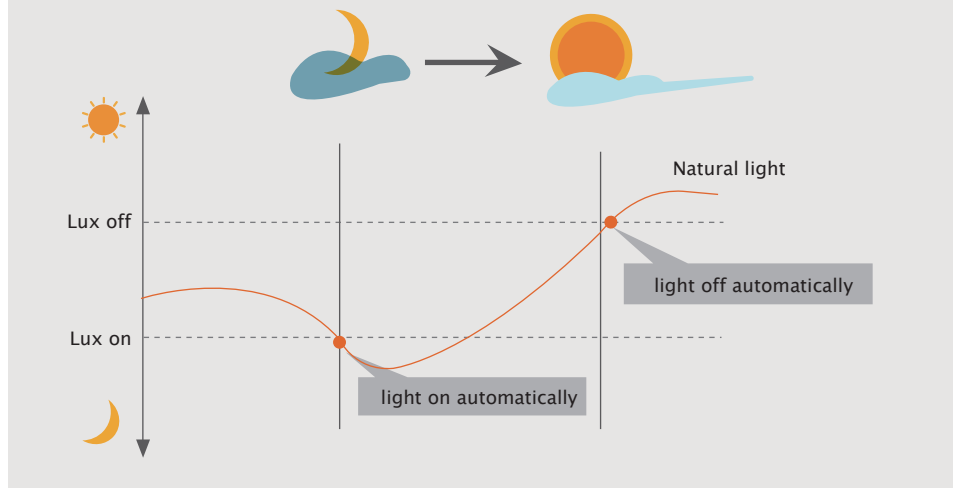

Application Daylight priority

- * Daylight threshold is on 30Lux/50Lux/80Lux/120Lux;
- * Standby period is $+\infty$; Standby dimming level is on 10%/20%/30%.

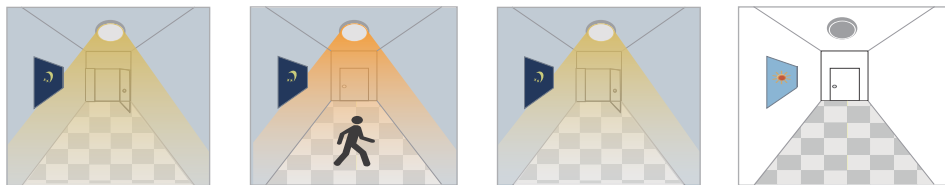

Light automatically on when ambient brightness is lower than preset lux level.

With insufficient ambient brightness, light dims to 100% when motion detected.

Light dims to standby level if no motion detected after holdtime.

Light off when ambient lux level is higher than preset lux amount.

Application

1. Automatically ON/OFF function:

- * Daylight threshold is on 2Lux/10Lux/30Lux/50Lux/80Lux/120Lux/200Lux;
- * Standby period is 0s; Light on when detect movement and off after people leave at night. Applications: Corridor, Staircase.

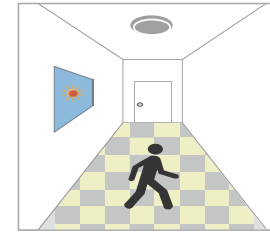

With sufficient daylight, even when motion detected, light remains OFF.



With insufficient daylight, when motion detected, light ON.

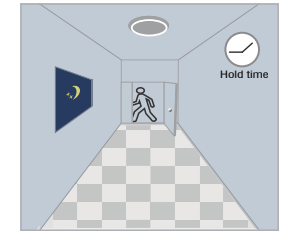

After the last detection and the present hold time elapsed, light OFF.

2. No daylight function

- * Daylight threshold is on "Disable"; Standby period is on 0s/10s/30s/1 min/5min/10min/30min/60min.
- * Light on when detect movement, After people leave, Light off after stand-by period.
- * Stand-by period is set to $+\infty$, The light will always remain ON.

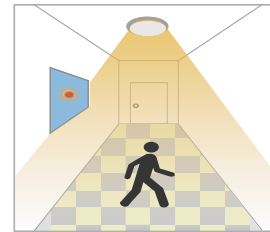

When motion is detected, the sensor will switch on the light to 100% brightness.

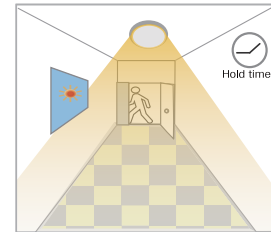

After people leave the detection area, light remains 100% brightness within hold time.

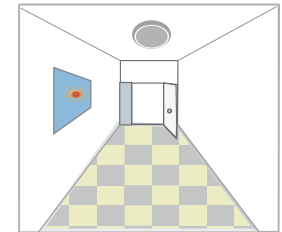

After the last detection and the present hold time elapsed, light OFF.

3. Function Demo – Dimmable control/Corridor function

- * Daylight threshold is on 2Lux/10Lux/30Lux/50Lux/80Lux/120Lux/200Lux;
- * Standby period is on 0s/10s/30s/1 min/5min/10min/30min/60min.
- * Light on when detect movement and off after people leave at night. Applications: Corridor, Staircase.

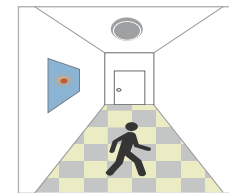

With sufficient daylight, even when motion detected, light remains OFF.



With insufficient daylight, when motion detected, light ON.

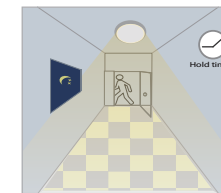

After last detection, the light will be dimmed down to the stand-by dimming level (10%, 20%, 30% or 50%) after holdtime.

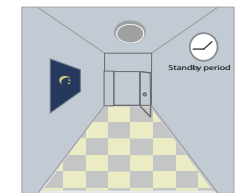

After the stand-by period, light OFF.

HD05R Remote Control Keys Function Introduction



| Remote Keys | Keys Function | Keys Introduction |
|-------------|------------------------|---|
| | ON/OFF | Switch ON/OFF the light; Switch OFF the sensor function. |
| | MW/PIR | Mode Switch |
| | Reset | Switch to Sensor mode and recover all settings to be factory defaulted setting(Detection area-100%, Hold time-5s, Daylight- Disable, Standby Period-0s, Stand-by dimming level-10%. |
| | Start | Press the key to start the setting of parameters with memory and apply function under the sensor mode. |
| | Memory | 1. Press "Start", there will be a letter "S" flashes in the lower left corner of the display, then start to set up all parameters; 2. After setting all parameters, press "Memory" to store the settings and keep it until the next reset; 3. Press "Apply" to the set sensor with stored settings within the remote IR range ; 4. Note: All data shown in the display are the settings after pressing "Memory". |
| | Apply | |
| | Detection area | |
| | Hold time | Under sensor mode, press the key, the corresponding icon on the display flashes, press "+" / "-" to select the hold time. |
| | Daylight Threshold | Under sensor mode, press the key, the corresponding icon on the display flashes, press "+" / "-" to select the daylight threshold. |
| | Stand-by period | Under sensor mode, press the key, the corresponding icon on the display flashes, press "+" / "-" to select the low brightness time. |
| | Stand-by dimming level | Under sensor mode, press the key, the corresponding icon on the display flashes, press "+" / "-" to select the low brightness during stand-by period. |
| | UP | After pressing different parameter keys, press either of the key to adjust(UP/DOWN) the required parameters. |
| | DOWN | |
| | POWER | Under sensor mode, press "POWER", the letter of "PW" flashes in the middle left of the display, press "+" / "-" to increase/decrease the output power. |
| | Test mode | Press the key to enter the test mode under sensor mode. It won't be memorized after power OFF. The parameters under test mode is: detection area-100%, hold time-2s, daylight-disable, stand-by period-0s, stand-by dimming level-10%. |
| Notes | | Press "Scene" to reset the remote before using. During the setting of each parameter, the icon will flash for 5s, after that, the setting will be kept automatically. |

HD05R Remote Control Procedure



1. Microwave motion sensor settings- One sensor

- ① Step 1 – Press "ON/OFF" to turn on the light.
- ② Step 2 – Press "Scene" to reset the remote and switch to sensor mode.
- ③ Step 3 – Press related keys to set Detection Area, Hold Time, daylight threshold, stand-by period and stand-by dimming level with pressing "+" / "-" within 5s when the icon start to flash.
- ④ Then all settings would be kept automatically until the next reset.

2. Start / Memory / Apply-Applied to more sensor

- ① Press "ON/OFF" to turn on the light
- ② Press "Scene" to enter sensor mode. Then press "Start" to start the user-defined setting.
- ③ Press related keys to set Detection Area, Hold Time, daylight threshold, stand-by period and stand-by dimming level with pressing "+" / "-" within 5s when the icon start to flash.
- ④ Press "Memory" to store the setting.
- ⑤ Press "Apply" to all sensor within remote IR range, the light will blink rapidly when receiving the signal, means the sensor has been set successfully.

2. Power Output Setting

- ① The output could be set under two mode-Sensor Mode and Always ON Mode.
- ② Under always ON mode, press "+" / "-" to adjust the output from 10%~100%.
- ③ Under the sensor mode, press "Scene"- "Power", then press "+" / "-" to adjust the output from 60%~100%.

* Note: Under the sensor mode, the data shown in the display could be set from 10%~100%, but the brightness would be 60% at lowest and won't dim any more.