

986PK0101-NWG

**The model number of your item is printed on the side of your carton.
Always use this number to identify your item.**

Thank you for your purchase of this quality Outdoor Decor. With proper use and care, your Outdoor decor will provide you with years of enjoyment. Please follow the instructions on how to assemble and disassemble your item. If you should have any problems with your item, or you have any questions, DO NOT return it to the place of purchase. Please call our toll-free number: **1-877-397-5144** and a customer service representative will assist you. Enjoy your Product!

Please read instruction manual carefully before use and follow the instructions step-by-step.

This product has components that are made of wood, a natural product than can have variations in texture and color depending on temperature and humidity. This means that the wood can expand during periods of high humidity and contract or shrink in times of low humidity. The expansions and contractions can cause minor scratches and cracks in the surface. After a period of time, wood can change color, which is a natural process. This does not affect the durability of the wood. Please enjoy the beauty and variability of this natural product!

If you do not plan to assemble your item shortly after opening, please store the remaining pieces away from sunlight and moisture.

TOOLS THAT MAY BE REQUIRED

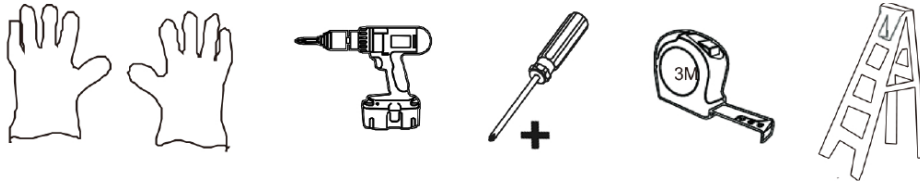

PLAN AHEAD



Watch the weather: Be sure the day you select for installation is dry and calm.

DO NOT attempt to assemble this item in windy weather because of risk of damage to panels or personal injury. Be careful of wet and muddy ground.

Teamwork: Whenever possible, two or more people should assemble. One person can position parts or panels while the other is able to handle the tools.

IT TAKES TWO PEOPLE ABOUT ONE TO THREE HOURS TO COMPLETE.

SITE SELECTION: The ground surface must be level. Installing on sloping ground can cause your item to lean or “rack”. Leaning puts additional stress on all connections and joints and in time will cause those connections to loosen and fail.

INSPECTION AND MAINTENANCE:

- To ensure the safety of this product, please inspect it carefully at the beginning of each season and twice monthly while in use.
- Check all hardware to be sure it is tight. Caution: overtightened hardware crushes the fibers of the wood and can result in split boards.
- Always check the product stability.

CAUTION:

- Please perform regular inspections and maintenance to ensure that the product is not prematurely ageing.
- Take all precautions necessary to safeguard the safety of children.

ENVIRONMENT PROTECTION: Please recycle materials properly when finished installing product.

WARNING!

- For domestic use only. Not for use in a commercial setting.
- Please place the playground equipment on a flat surface at a distance of at least 6 feet from other things such as: fences, garage, playsets, building structures (garage, shed, house), overhanging branches, clotheslines or electric cables.
- This playground equipment may not be placed on asphalt, concrete or other hard surfaces.

WARNING! May only be used under the supervision of an adult.



- This product is to be assembled by an adult and checked before each use.
- Minimum age: 36 months - this item is not suitable for children under 36 months of age. Risk of suffocation or choking caused by small parts that may be swallowed!
- Never leave child unattended when using this product.
- Incorrect installation can be dangerous. To prevent serious injury or death, securely install all of the components and only use according to the assembly instructions.
- Do not use the product if any components are damaged or missing. Before using the product, carefully inspect for any loose components and carefully tighten any parts that are loose.
- Make sure that the product is always on a flat surface. Improper installation can result in serious injury due to tipping or falling.

CLEANING AND MAINTENANCE

Note: The service life of the product may be substantially reduced if it is permanently exposed to the weather.

- **Hazard** - Check the product regularly for damage and dispose of it if necessary.
 - Check all nuts and bolts for tightness and tighten when required
 - Oil all metallic moving parts
 - Check all coverings for bolts and sharp edges and replace when required
 - Check metal parts for rust. Replace if needed
 - Replace any defective or missing parts
- If the above checks are not carried out, the product could break, overturn or otherwise become a hazard.
- Clean regularly and treat with conventional care products once or twice a year.

Storage

- Always store in a dry, well-ventilated place. Keep the product away from moisture.

ASSEMBLY INSTRUCTIONS

-  A 3.0*16 4pcs
- B 3.0*20 6pcs
- C 3.0*34 2pcs
- D 3.0*28 25pcs
- E 3.5*35 2pcs
- F 3.5*45 4pcs

 Plastic hook 3PCS

 Plastic handle 1PC

 Plastic knob 3PCS

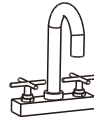
 Plastic tap 1PC

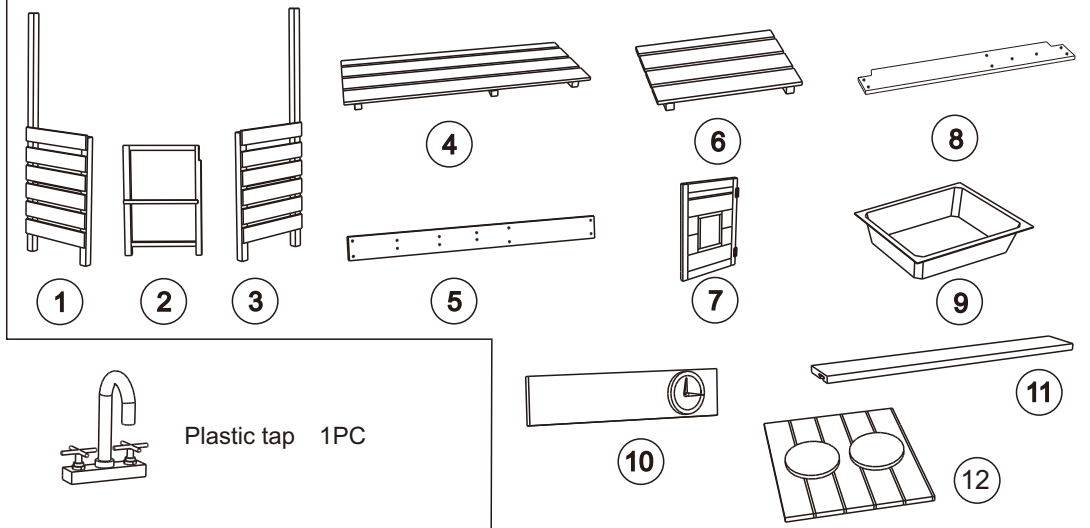

Step 1

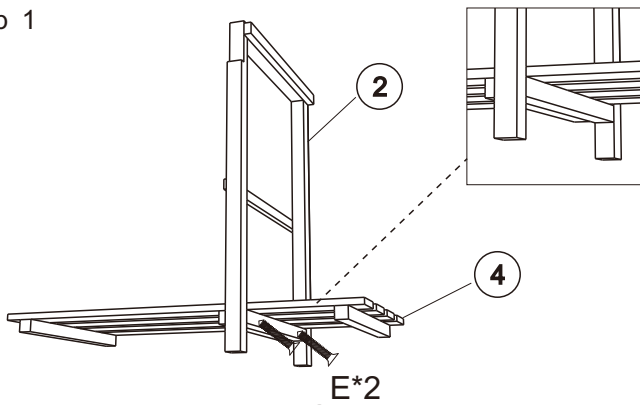

Connect part ② with part ④, secure with 2x screw(E).
 NOTE: (1)At the back of part ④, there are three wooden battens with different distances. The longer distance side faces left, while shorter distance side faces right.
 (2)For part ②, its middle batten needs to face left, used for holding middle shelf later. Its bottom batten is on the right side, next to the middle batten of part ④.

Step 2

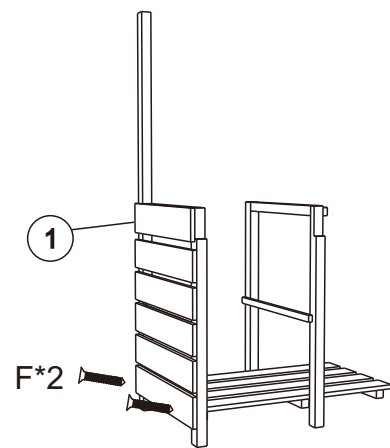

Connect left panel part ① to the left batten of part ④, and secure with 2x screw(F).

Step 3

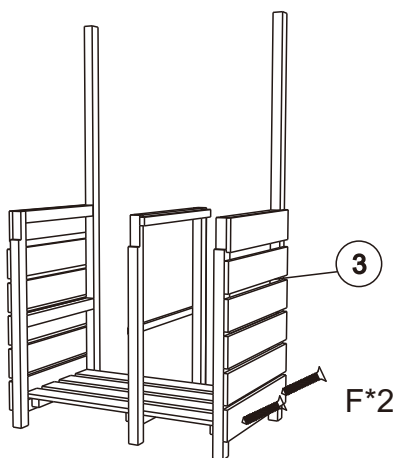

Connect right panel part ③ to the right batten of part ④, and secure with another 2x screw(F)

Step 4

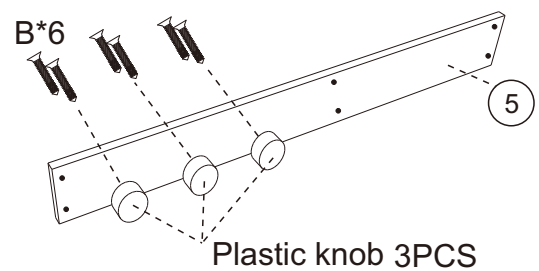

Fix 3x plastic knobs to part ⑤, each using 2x screw(B).

Step 5

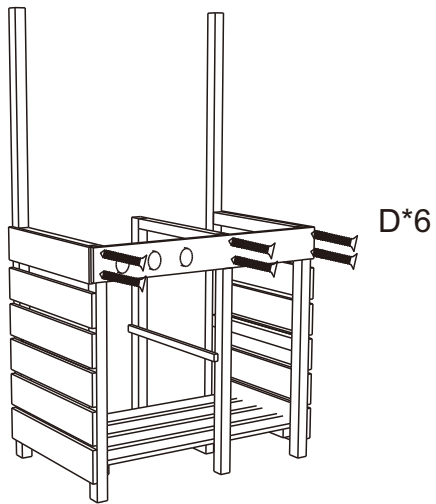

Connect the 2 parts finished in step 3 and 4, and secure with 6x screw(D).

Step 6

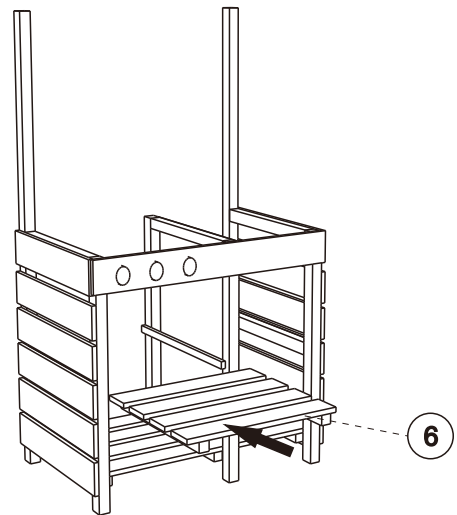

Place middle shelf part ⑥ .

Step 7

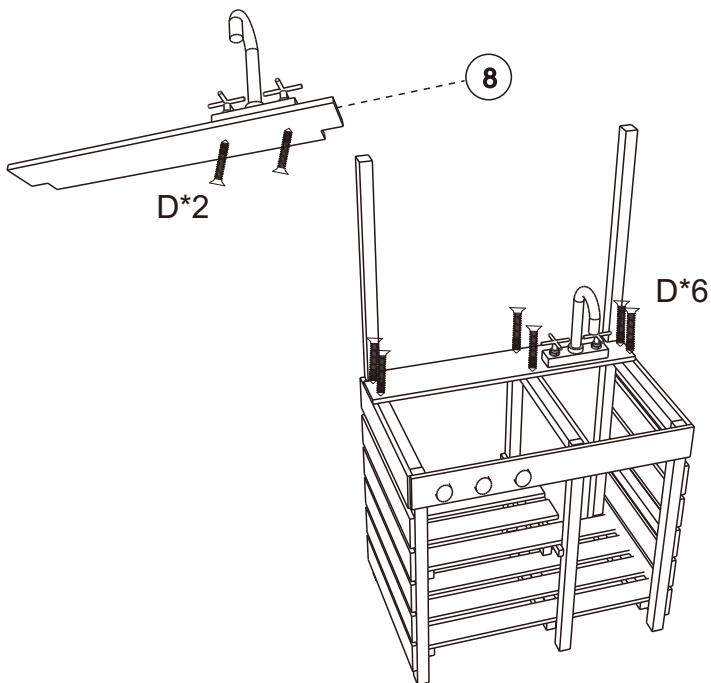

- (1) fix plastic tap to part ⑧ using 2x screw(D)
- (2) Secure part ⑧ using 6x screw(D)

Step 8

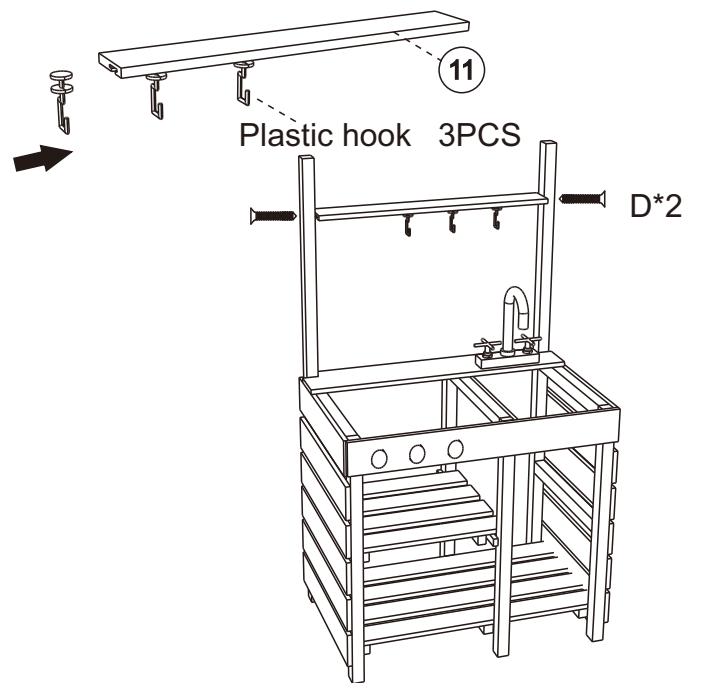

Slide 3x plastic hooks into part⑪, then secure part⑪ using total 2x screw(D).

Step 9

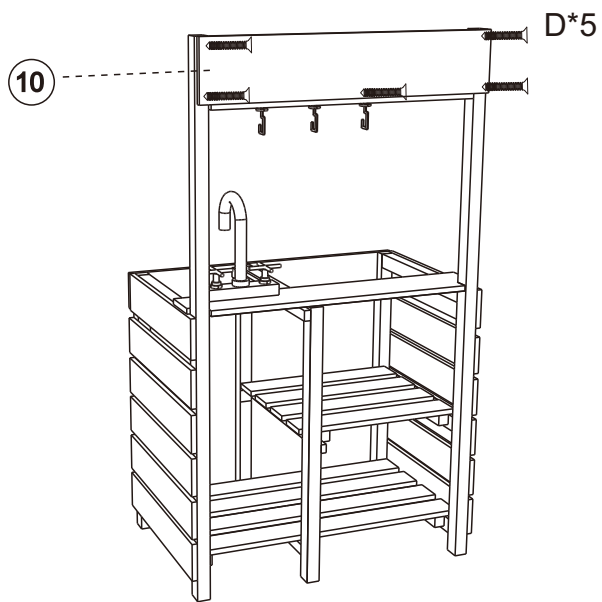

Secure part ⑩ from back using 5x screw(D).

Step 10

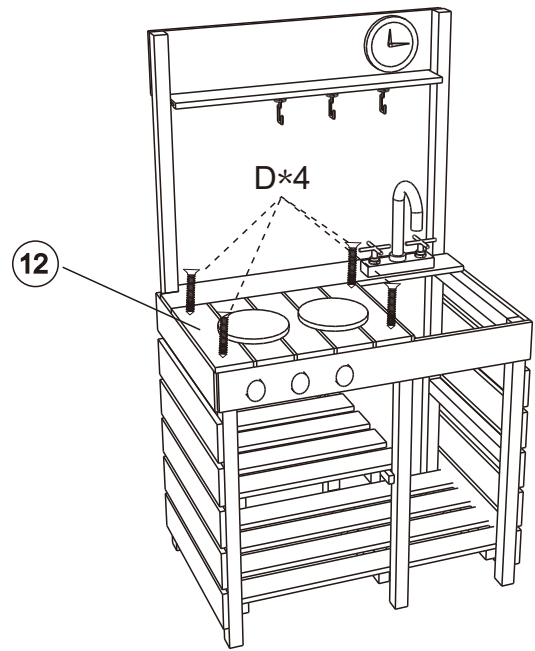

Secure part ⑫ using 4x screw(D) as shown.

Step 11

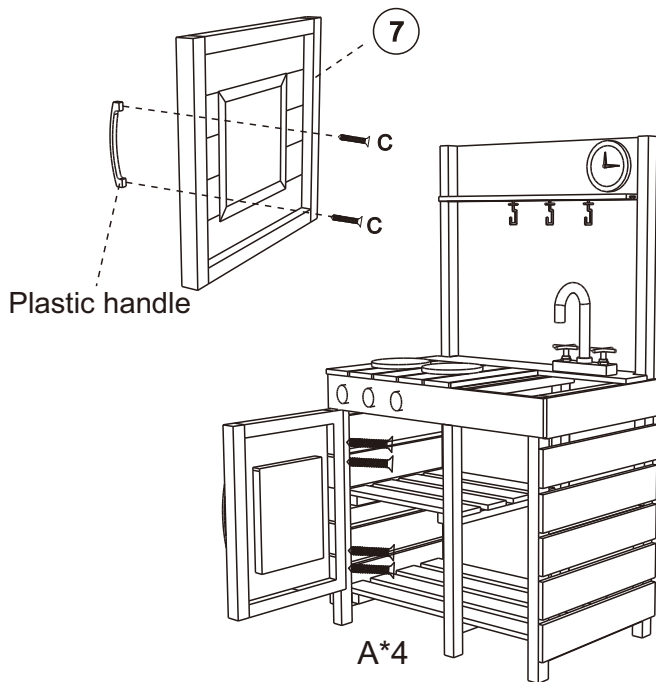

(1)secure plastic handle using 2x screw(C);
(2)Then secure the door using 4x screw(A).

Step 12

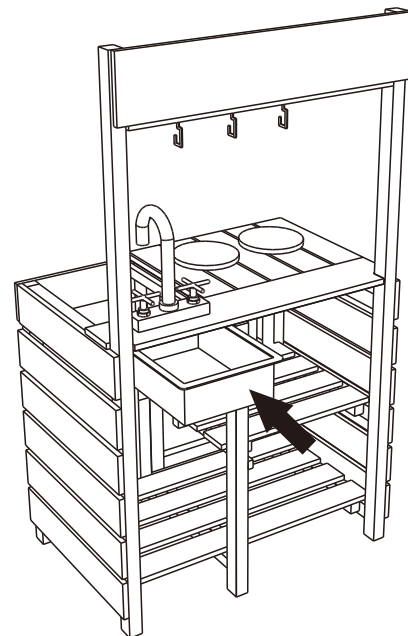

Slide in plastic sink part ⑨ from back.

Critter Sitters

1-Year Limited Warranty Program

For a period of one (1) year after purchase, Critter Sitters ("Manufacturer") will either repair or replace defective components in accordance with this Limited Warranty. This warranty is between Manufacturer and the original purchaser and is valid only when accompanied by the original purchaser's sales receipt showing original date of purchase and location of purchase. Replacements under this warranty revert back to the date of original purchase for future warranty.

Manufacturer or its authorized dealer can accept or reject warranty claims based on its findings. This warranty applies in normal residential use only and is not intended for commercial use. Manufacturer can make substitutions as required of materials, components, and sub-components of comparable value and utility. This warranty is limited to product repair or replacement (to be determined solely by Manufacturer). Warranty return is limited to only the single affected component.

This warranty covers only manufacturing defects and does not cover normal wear and tear, abuse or misuse, exposure to extreme heat or cold, abrasion or excessive weight. This product is intended to be used in standard installations only. This warranty is invalid if the product is not used for intended purpose. Manufacturer disclaims liability for any aspect of installation and any inconvenience caused by a defective part of a component.

Certain items are not covered by this warranty. These include, but are not limited to the following:

1. Components subjected to abuse, including abuse intended to simulate failure.
2. Damages caused by retailer, shipper or installation crew (such as scratches, dents, tears, chips, etc.).
3. Any part which merely exhibits normal wear yet functions essentially as new, including chips, scratches or stretching of materials and stitching.
4. Tears, punctures, scratches or any damage caused by improper installation or use.
5. Damage to frames/welds resulting from improper assembly is not covered. General frame rusting is not covered.
6. Fading and/or discoloration of fabrics resulting from exposure to the elements, chemicals, oils, fluids or any other cause are not covered.

To make a claim, call the toll-free number below. Please have available a copy of the original sales receipt along with a brief description of the problem. Please also provide your email address and daytime telephone or cell phone #. All items may be charged actual freight costs plus \$15 for handling. Repairs or replacement will be made at the Manufacturer's option. ***Sales and use taxes, plus shipping and handling charges are the responsibility of the consumer.***

THIS IS THE ENTIRE EXCLUSIVE EXPRESS LIMITED LIABILITY. THE MANUFACTURER NEITHER MAKES NOR IS RESPONSIBLE FOR ANY OTHER WARRANTIES, EITHER EXPRESS OR IMPLIED, INCLUDING THOSE OF RETAILING DEALERS. THIS EXCLUSIVE REMEDY IS LIMITED TO RECEIPT OF A CREDIT IN CONNECTION WITH THE REPAIR OR REPLACEMENT OF ANY PRODUCT OR COMPONENT DEEMED TO BE DEFECTIVE UNDER THE TERMS AND CONDITIONS AS STATED IN THIS WARRANTY. NEITHER CAMBRIDGE PRODUCTS, THE PRODUCT MANUFACTURER NOR ITS AGENTS SHALL BE LIABLE IN ANY CASE FOR INCIDENTAL, INDIRECT, SPECIAL OR CONSEQUENTIAL DAMAGES RESULTING FROM THE USE OF THIS PRODUCT OR ARISING OUT OF ANY BREACH OF THIS WARRANTY OR NEGLIGENCE EVEN IF IT HAS BEEN ADVISED OF THE POSSIBILITY OF SUCH DAMAGES. EXCEPT AS OTHERWISE MAY BE REQUIRED BY LAW, THERE ARE NO OTHER EXPRESS OR IMPLIED WARRANTIES OTHER THAN THE WARRANTY DESCRIBED HEREIN, AND ALL OTHER WARRANTIES, INCLUDING ANY IMPLIED WARRANTY OF MERCHANTABILITY OR FITNESS FOR A PARTICULAR PURPOSE ARE EXPRESSLY DISCLAIMED.

**Contact Warranty Services at
1-888-840-4557 or
Luv@MyCritterSitters.com**