

LARGE EVENT 8-BURNER GAS GRILL

PARRILLA DE GAS PARA EVENTOS DE 8 QUEMADORES

GRIL À GAZ EVENT À 8 BRÛLEURS

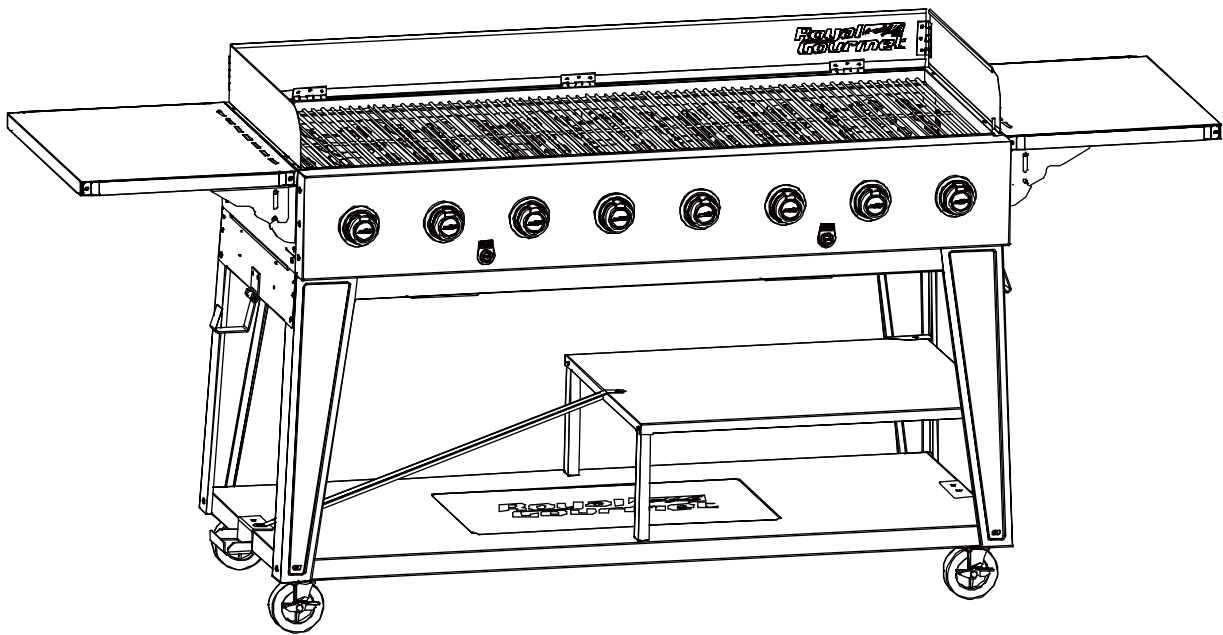

FOR YOUR SAFETY! | ¡PARA SU SEGURIDAD! | POUR VOTRE SÉCURITÉ!

Use outdoors only!
Read the instructions before
assembling and using the appliance.

¡Solo usa al aire libre!
Lea las instrucciones antes
de montar y utilizar el aparato.

Utilisez uniquement à l'extérieur!
Lisez les instructions avant
d'assembler et d'utiliser l'appareil.

CONTACT US FIRST! | ¡PÓNGASE EN CONTACTO CON NOSOTROS PRIMERO! | CONTACTEZ-NOUS D'ABORD!

If you have any questions that are
not addressed, please contact us first.

Si tiene alguna pregunta que no se
aborde en este Manual del Usuario,
póngase en contacto con nosotros primero.

Si vous avez des questions qui ne
sont pas traitées dans ce manuel de
l'utilisateur, contactez-nous d'abord.



Customer Service / Servicio al Cliente / Service de Clientèle

1-800-618-6798









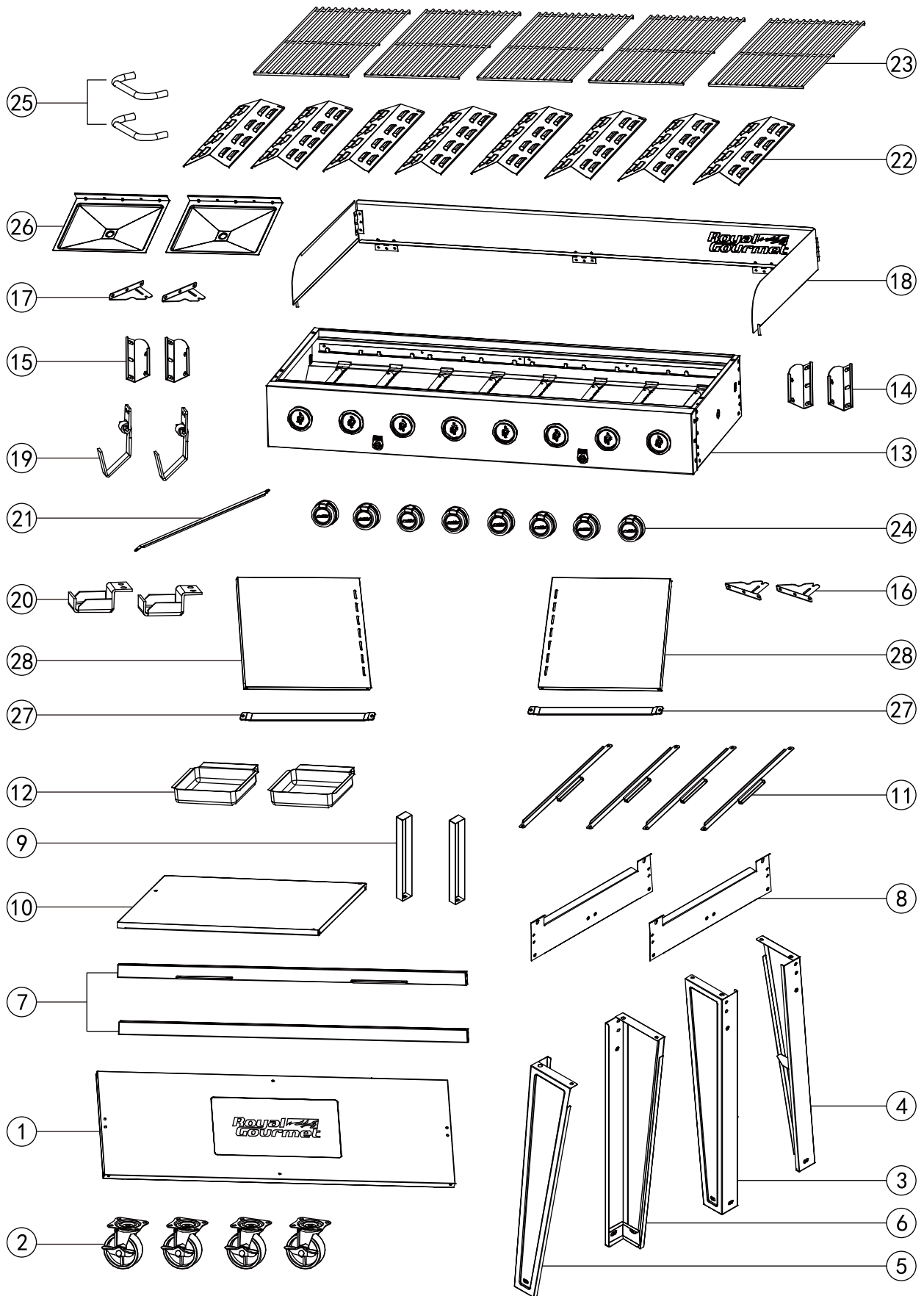





service@royalgourmetusa.com







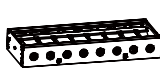

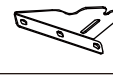
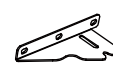
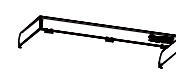
Learn more at / Obtener más información en / Pour en savoir plus:

www.royalgourmetcorp.com



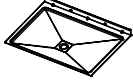

No.	#	QYT / CANT. / QTÉ	Description / Descripción / Description	Image / Imagen / Image
1	GD17J2DB03H8B	1	Bottom shelf Estante inferior Etagere inferieure	
2	05-WXL-26	4	Caster Rueda Roulette	
3	GD17J2JRF01H	1	Right front leg Pata delantera derecha Jambe avant droite	
4	GD17J2JRB01H	1	Right back leg Pata trasera derecha Jambe arrière droite	
5	GD17J2JLF01H	1	Left front leg Pata delantera izquierda Jambe avant gauche	
6	GD17J2JLB01H	1	Left back leg Pata trasera izquierda Jambe arrière gauche	
7	GD17JHL01H8B	2	Cart beam Barra del carro Poutre de chariot	
8	GD17JCGDB01	2	Side cart beam Barra lateral del carro Poutre latérale du chariot	
9	GD17JCBZC01	2	Shelf support Soporte del estante Support d'étagère	
10	GD17JCB028B	1	Upper shelf Estante superior Etagere superieure	
11	GD17JYBZC02	4	Grease cup brace Soporte de la depósito de recogida de grasa Support de bac à graisse	
12	TY-YB01-LS4	2	Grease cup Depósito de recogida de grasa Bac à graisse	
13		1	Main body Cuerpo principal Corps principal	
14	GD17T4ZJR01	2	Side table joint (R) Bisagra de mesa lateral (D) Joint de table d'appoint (D)	
15	GD17T4ZJL01	2	Side table joint (L) Bisagra de mesa lateral (I) Joint de table d'appoint (G)	
16	GD17T4ZJR02	2	Side table folding bracket (R) Soporte plegable de la mesa lateral (D) Support pliable de la mesa lateral (D)	
17	GD17T4ZJL02	2	Side table folding bracket (L) Soporte plegable de la mesa lateral (I) Support pliable de la mesa lateral (G)	
18	GD17LHDFB02H GD17LDFBL03H GD17LDFBR03H	1	Wind deflector Deflector de viento Deflecteur de vent	

No.	#	QYT / CANT. / QTÉ	Description / Descripción / Description	Image / Imagen / Image
19	07-QPG-01-BK	2	LP cylinder hook Gancho para bombona de gas Crochet de bouteille de gaz	
20	07-QPG-02-BK	2	LP cylinder base Base del bombona de gas Base de bouteille de gaz	
21	GD17JQPDG016B	1	LP cylinder barrier bar Barra de seguridad para la bombona de gas Barre de barrière de bouteille de gaz	
22	TY-FHB01	8	Flame tamer Regulador de llama Atténuateur de flamme	
23	03-XKW-GD-01-A-TC3	5	Cooking grate Rejilla para asar Grille de cuisson	
24	06-XNL-6-04-RD-RGC	8	Knob Perilla Bouton	
25	04-GBS-2-04-248-PT2	2	Grease tray handle Manija bandeja de grasa Poignée du lèchefrite	
26	GD17LJYP038B-DS1	2	Grease tray Bandeja de recogida de grasa Lèchefrite	
27	GD17T4ZSGJ01	2	Utensil rail Riel para utensilios Rail à ustensiles	
28	GD17T4CT	2	Side table Mesa lateral Table d'appoint	

Key / Clave / Réf.	Description / Descripción / Description	QTY / CANT. / QTÉ	Image / Imagen / Image
A	M6x12	59	
B	M5x10	24	
C	M4x8	6	
D	M6	2	
E	M6x15	4	
F	M6x20	8	
G	M6x25	8	
H	M6x16	8	

TOOLS REQUIRED / HERRAMIENTAS REQUERIDAS / OUTILS REQUIS		
Description / Descripción / Description		Image / Imagen / Image
Phillips screwdriver Destornillador phillips Tournevis phillips	Wrench Llave Clé	

Before beginning assembly, make sure all parts are present. If any parts are missing or damaged, do not attempt to assemble the products. Contact customer service for replacement parts via telephone or email.

- Tools needed (not included): Phillips screwdriver and wrench
- Approximate assembly time: 45 minutes
- Note: 1. The right and left sides of the grill are designed as if you are facing the front of the grill.
2. Model shown for illustration purpose only, specific please in kind prevail.

Antes de comenzar el montaje, asegúrese de que todas las piezas estén presentes. Si falta alguna pieza o está dañada, no intente ensamblar los productos. Póngase en contacto con el servicio de atención al cliente para obtener piezas de repuesto por teléfono o correo electrónico.

- Herramienta necesaria (no incluido): Destornillador phillips y llave
- Tiempo aproximado de ensamblaje: 45 minutos
- Nota: 1. Los lados derecho e izquierdo de la parrilla están diseñados como si estuvieras frente a la parte delantera de la parrilla.
2. El modelo que se muestra es sólo para fines ilustrativos, prevalecen los específicos en especie.

Avant de commencer l'assemblage, assurez-vous que toutes les pièces sont présentes. Si des pièces sont manquantes ou endommagées, n'essayez pas d'assembler les produits. Contactez le service de clientèle pour les pièces de rechange par téléphone ou par e-mail.

- Outils nécessaires (non inclus): Tournevis phillips et clé
- Temps nécessaire pour l'assemblage: 45 minutes
- Remarque: 1. Les côtés droit et gauche du gril sont conçus comme si vous faisiez face à l'avant du gril.
2. Le modèle est présenté à des fins d'illustration uniquement, spécifiques en nature prévalent.

1 B  ×16

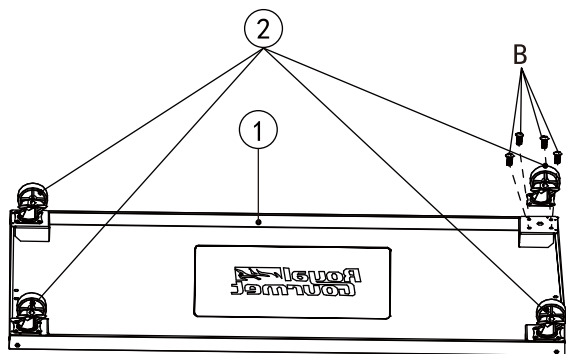

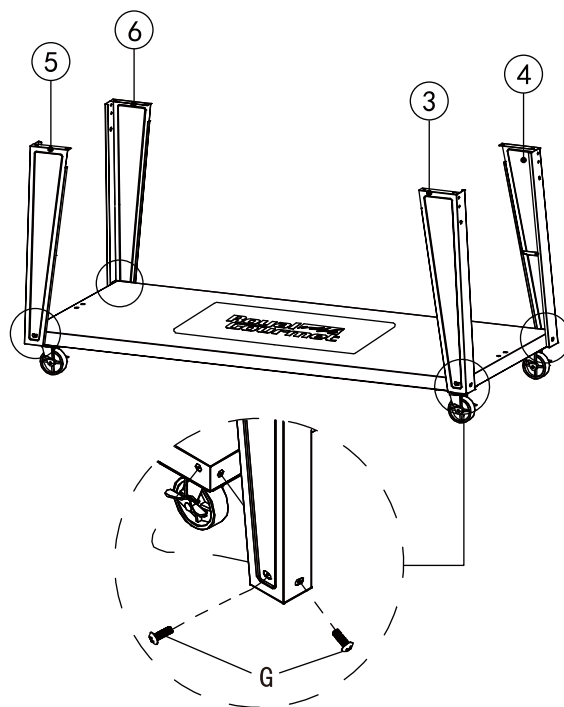

2 G  ×8

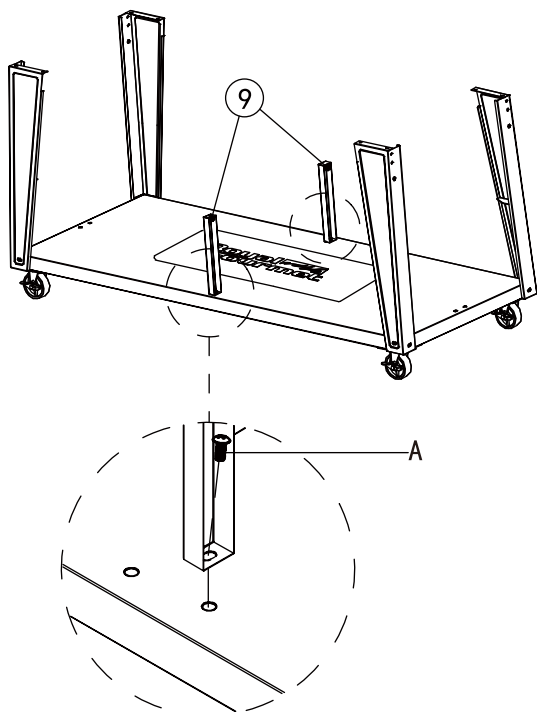

3 A  ×2



4 D  ×2
A  ×4

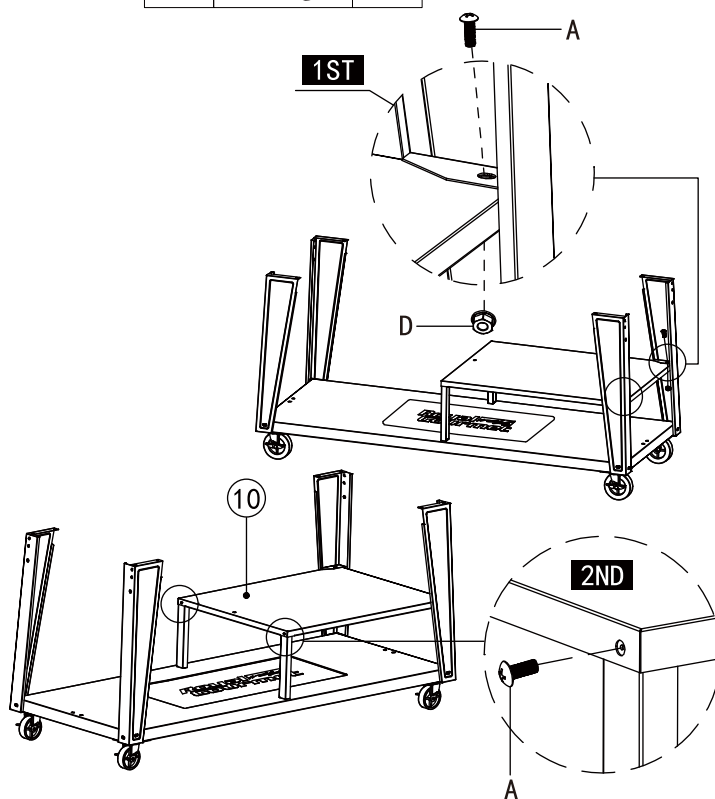

5 A  x4

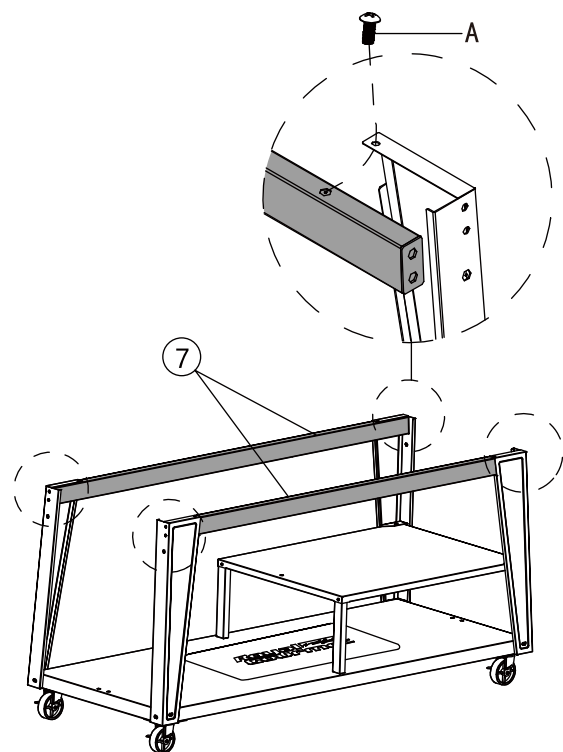

6 A  x12

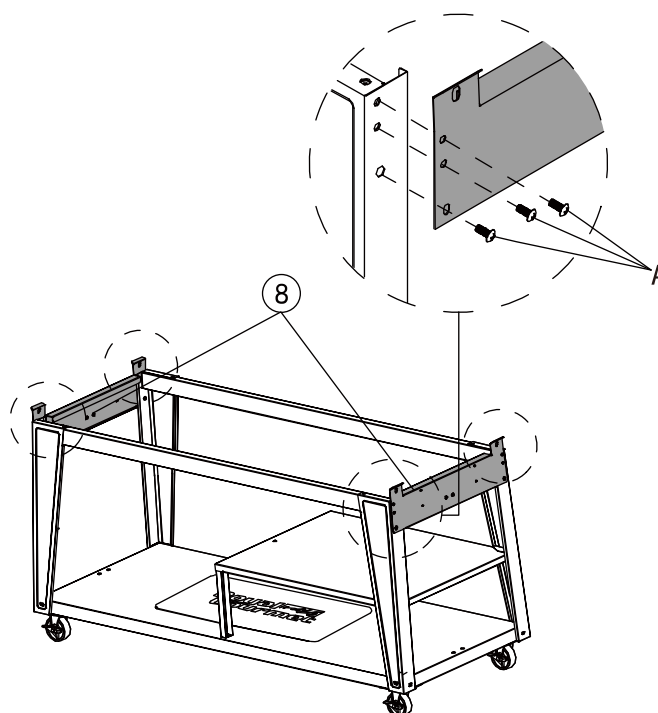

7 F  x8

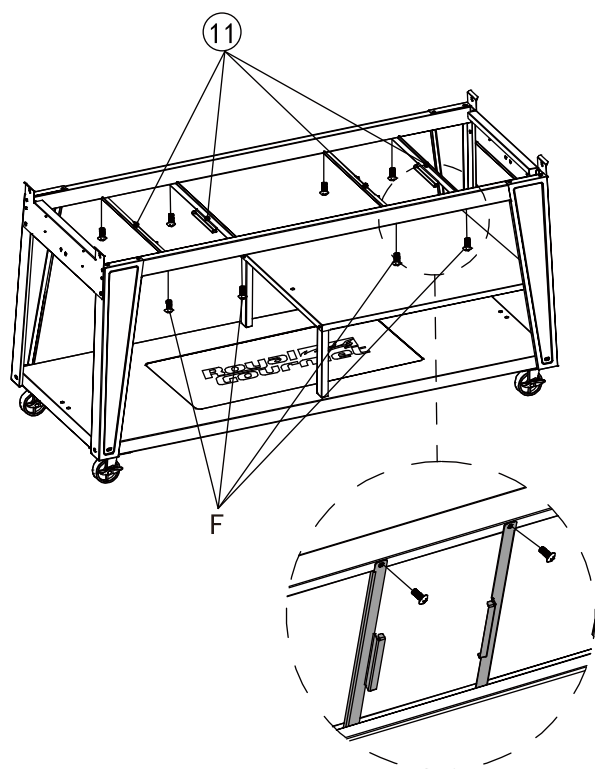

8

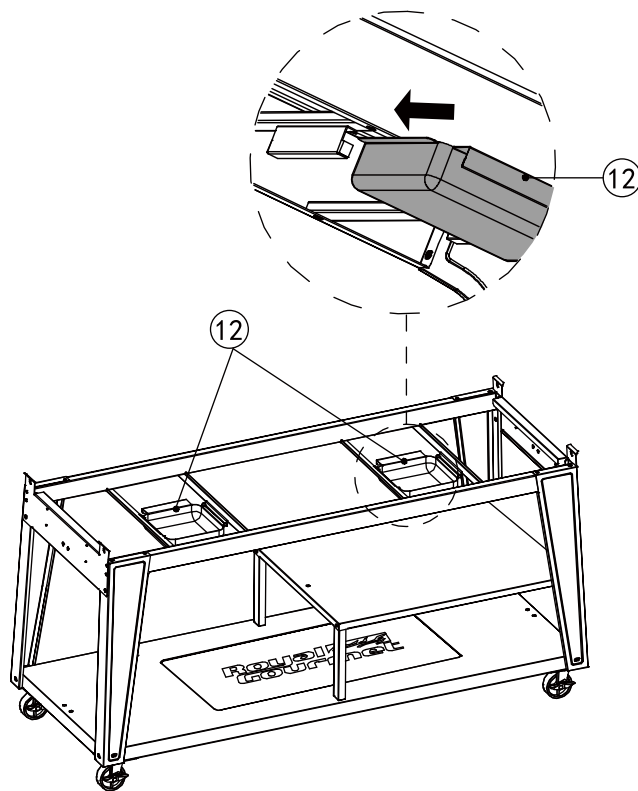

9 B  ×4

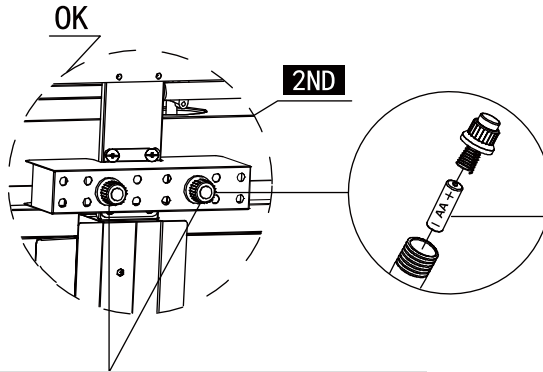
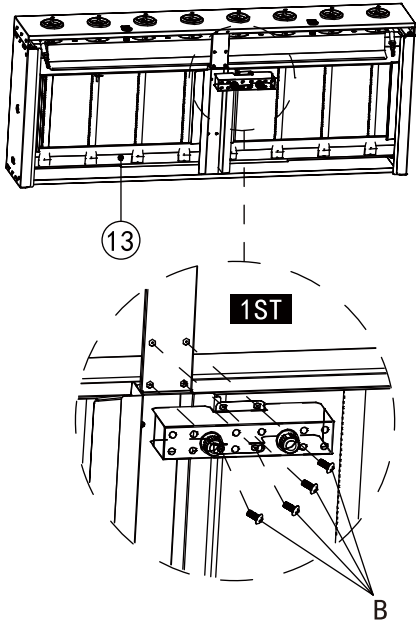

- AA battery not included.
- Pila AA no incluida.
- Pile AA non incluse.

- Unscrew caps and install batteries.
- Desenrosque las tapas e instale las pilas.
- Dévissez les capuchons et installez les piles.



10 A  ×4

- Release regulator assembly & ignitors in advance.
- Libere el conjunto del regulador y los encendedores por adelantado.
- Libérer l'ensemble du régulateur et les allumeurs à l'avance.

11 A  ×12

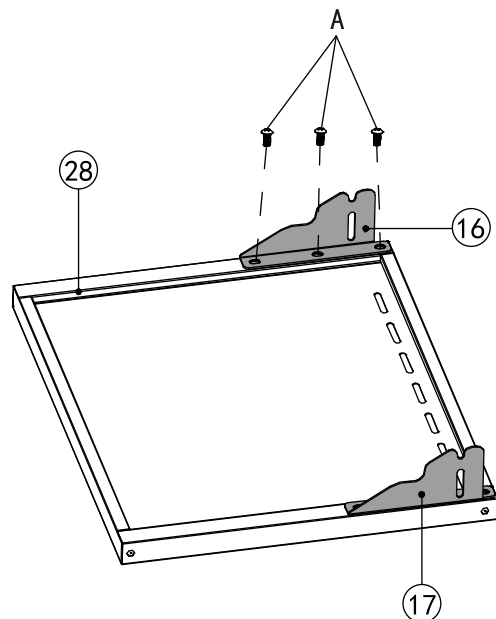
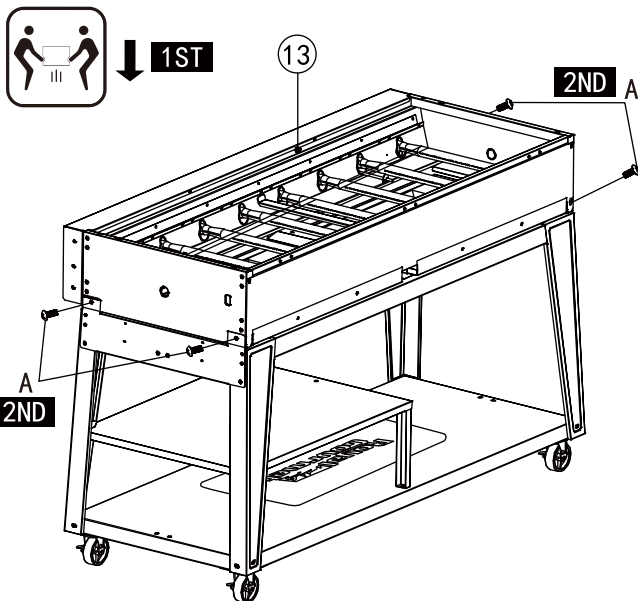

- Assemble both side tables.
- Ensamble ambas mesas laterales.
- Assemblez les deux tables d'appoint.

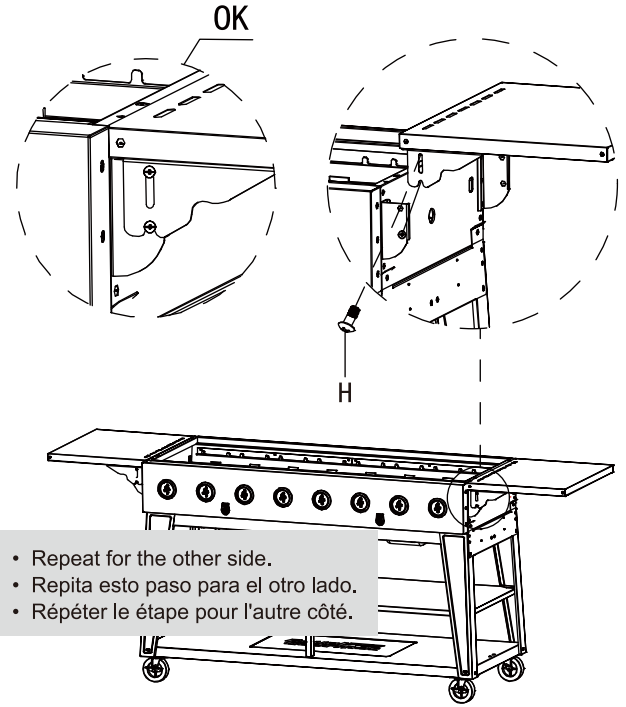
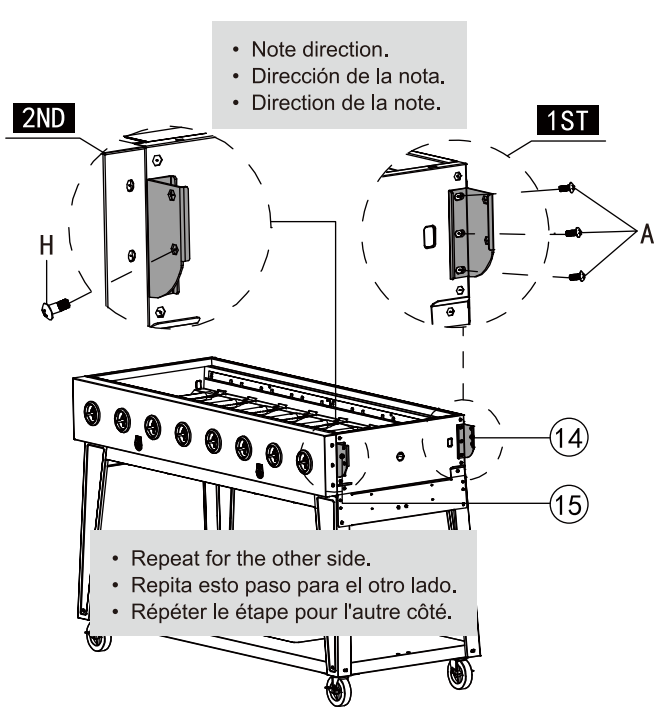

12	A		×12
	H		×4

13	H		×4
-----------	---	--	----



14	A		×9
	C		×6

- Assemble hooks&bases on both sides.
- Ensamblar los ganchos y las bases en ambos lados.
- Assemblez les crochets et les bases des deux côtés.

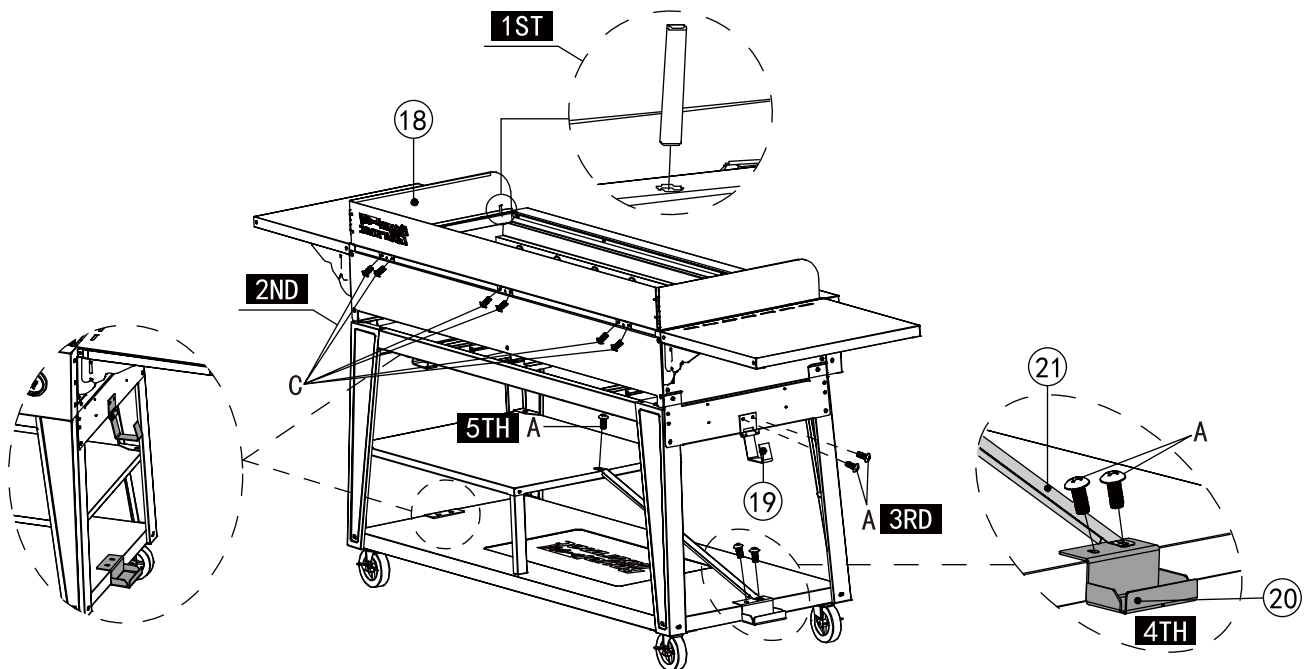

15 B  x4

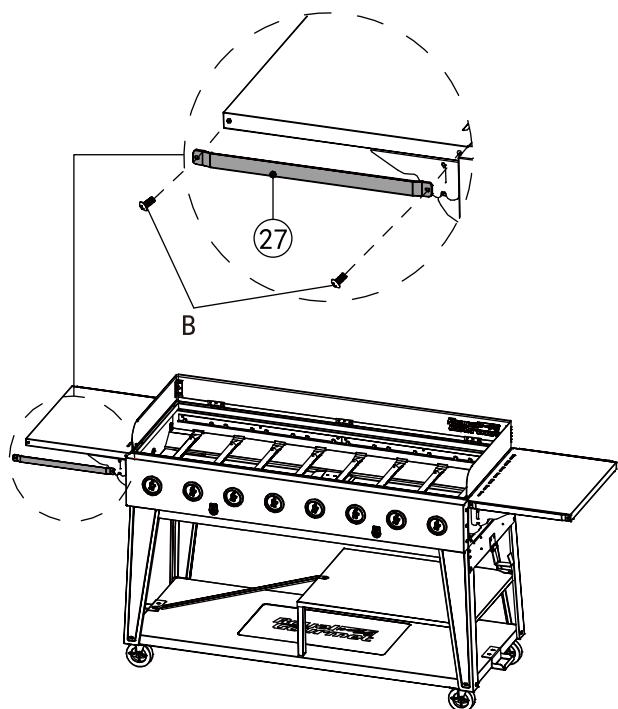

16

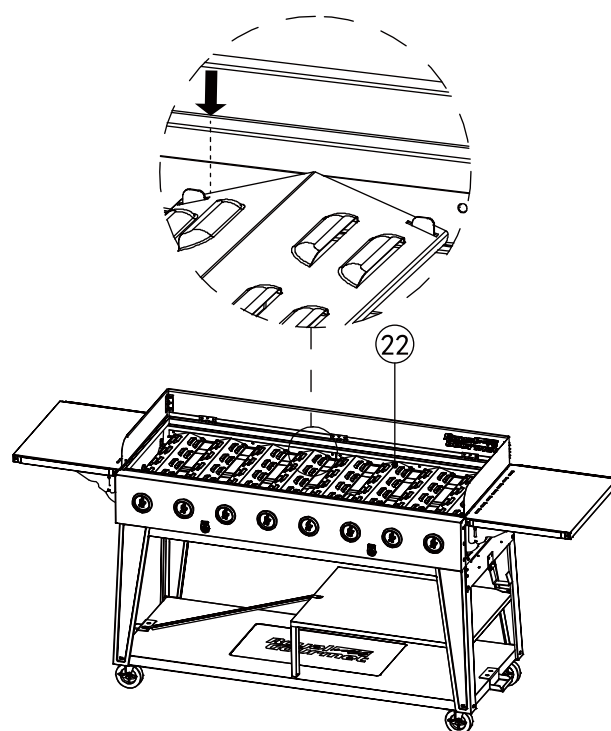

17

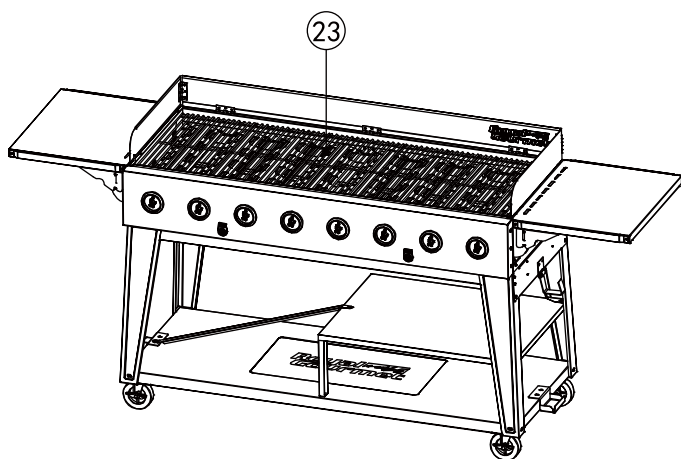

18

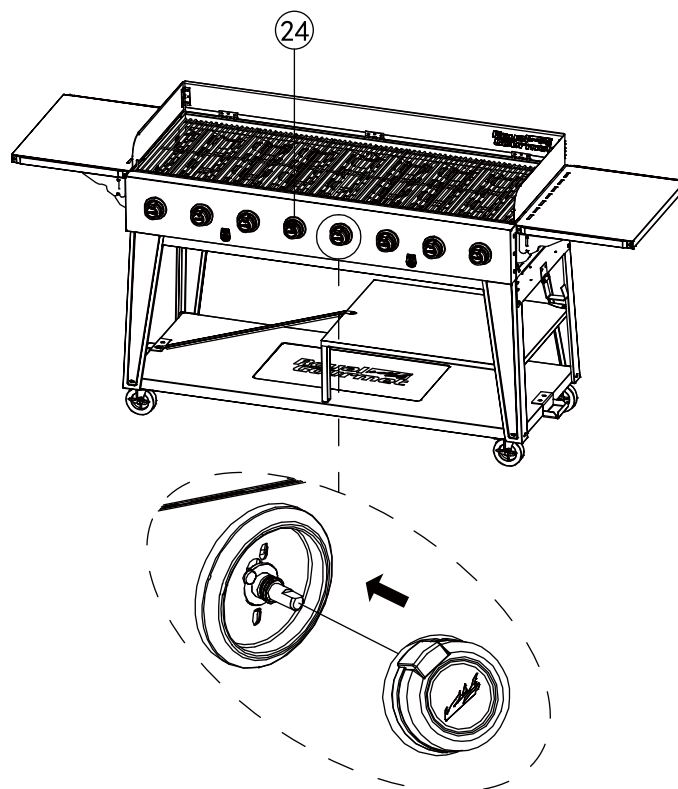

19 E  ⊕ ×4

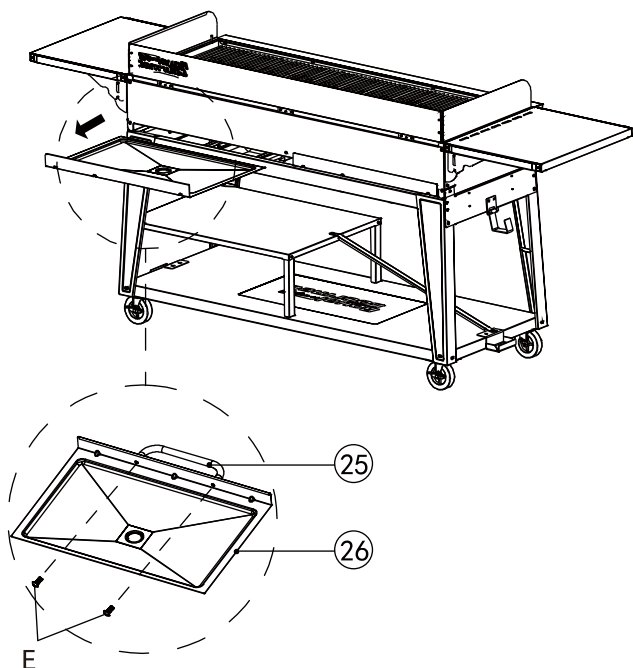

20

- NOTE: Secure cylinders onto hooks and bases.
- REMARQUE: Asegure el bombona en el gancho y la base.
- NOTA: Fixez la bouteille sur le crochet et la base.

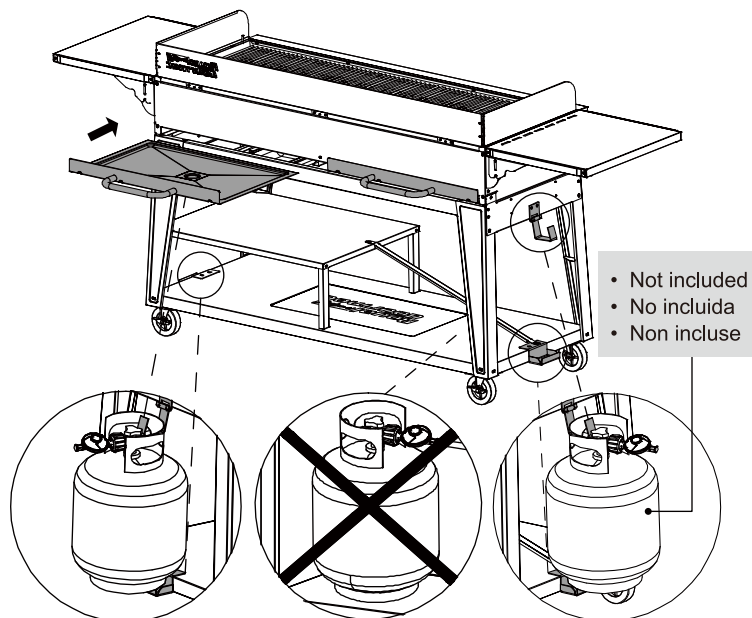

**Thank You
For Choosing Us.**

**Any Problem!
We Can Help!**

**Customer
Service**

1-800-618-6798

Monday to Friday (8:30 am - 5:00 pm EST)

service@royalgourmetusa.com