



36"/41" Tool Chests & Rolling Tool Cabinets & Combos

OPERATOR'S MANUAL

 Combo: 93606C2-06A4	 Chest: 93606C2
	Cabinet: 953606A4

 Combo: 94106R2-10S7	 Chest: 94106R2
	Cabinet: 954110S7

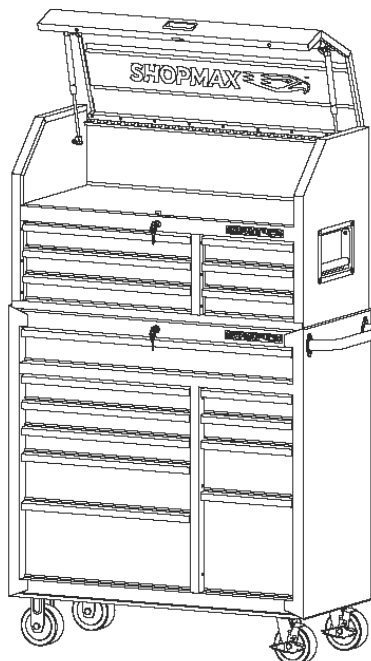
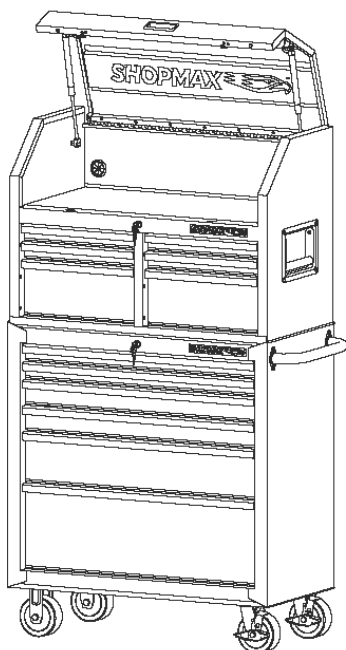

Some instructions and drawings may not apply to your specific unit.

SERIAL NUMBER

PURCHASE DATE

Both model number and serial number may be found on the carton. You should record both of them in a safe place for future use.

WARNING 







Carefully read and understand this entire operator's manual before installing and using this product. Pay attention to all the cautions and warnings.

SPECIFICATIONS

Model	Drawer Slide Weight Rating	Weight Capacity
93606C2-06A4 (Combo)	100 lbs	1500 lbs
993606C2 (Chest)		600 lbs
953606A4 (Cabinet)		1200 lbs
94106R2-10S7 (Combo)	100 lbs	1800 lbs
994106R2 (Chest)		600 lbs
954110S7 (Cabinet)		1200 lbs

SYMBOLS

The labels on your product may show symbols. These represent important information about the product or instructions on its use.

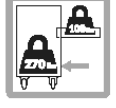
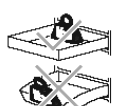
	Read and follow all safety rules and operating instructions.
	Keep wheels locked when not moving this product. This will prevent the product from rolling.
	Recommended 2-person lift. Remove contents before moving.
 	Close and lock drawers before moving this product.
	Keep children and bystanders off and away from product.
 	Do not fully open a drawer loaded to full capacity unless the closed drawers contain a total of at least 270 pounds of content.
	Distribute contents of loaded drawers evenly. Load drawers starting in the back first and load forward as needed.

	Watch for falling if placed or stored overhead.
	DO NOT drag while moving – always push.
	Keep the product on level surfaces.
	DO NOT step in the drawers.
	Do not stand on this product.
	DO NOT open more than one drawer at a time.
	Never exceed maximum weight capacity for each drawer or shelf.
	DO NOT drop heavy objects into drawers or push down on open drawers.
	DO NOT exceed the maximum height capacity for each drawer or shelf.
	Be careful when closing drawers or doors. Remove hands before drawers or doors close completely.
	Remove hands before cover closes completely.
	Electrical shock hazard. Do not plug cord into outlet if hands are wet.

SAFETY

SIGNAL SAFETY WORDS DEFINITION

The definitions below give the level of severity for each signal word.

DANGER

This symbol is used to indicate a hazardous situation which, if not avoided, will result in serious injury or death.

WARNING

This symbol points out safety instructions. Read and follow all instructions before attempting to operate this product. Failure to comply with these instructions could result in serious injury or death.

CAUTION

This symbol indicates a hazard, which, if not avoided, may result in minor injury, moderate injury, or property damage.

NOTE

This information makes the product easier to use.

ASSEMBLY SAFETY

WARNING

- Assemble only according to these instructions. Improper assembly can create hazards.
- Wear ANSI-approved safety goggles and heavy-duty work gloves during assembly.
- Keep assembly area clean and well lit.
- Keep bystanders out of the area during assembly.
- **DO NOT** assemble when tired or when under influence of alcohol, drugs or medication.
- Weight capacity and other product capacities apply to properly and completely assembled product only.
- Assemble on a flat, level, hard and smooth surface capable of safely supporting a fully loaded Chest/Cabinet.

OPERATION SAFETY

DANGER

- **DO NOT** sit, stand or climb on this unit.
- This product is not a toy nor a toy chest. Do not allow children to play with or near this item.
- Be aware of dynamic loading! Sudden load movement may briefly create excess load causing product failure. Do not exceed capacity of the bench or shelf supporting Top Chest.
- **DO NOT** open more than one drawer at once. This chest/cabinet/workbench may become unstable and tip over causing personal injury and/or product damage.
- Be careful when closing the drawers, the cover or doors. Remove hands before the cover/drawer/door close completely to prevent personal injury.
- **DO NOT** place any objects on top of a closed lid.

WARNING

- Make sure the lid lock or drawer lock is in the unlocked position before closing the lid or drawer. Failure to do so could result in a defective lock system and/or personal injury.
- Before locking, make sure the drawers are completely closed in order for lock system to work properly.
- Empty, close, and lock drawers before moving.
- **DO NOT** pull this product, push it when moving. Pushing the unit will prevent serious ankle and foot injuries.
- **DO NOT** move the item after stacking the top chest on the bottom cabinet, it could cause the chest to topple.
- Use only on flat, level, hard and smooth surface capable of safely supporting a fully loaded Chest/Cabinet. Do not roll Cabinet over concrete seams or other rough/uneven surfaces.
- **DO NOT** move or lift while loaded. Do not lift using handle(s).
- To prevent tipping, move using supplied handle on Bottom Cabinet only.
- Apply caster brakes unless moving the item.
- Secure this product properly before moving it with a forklift.
- **DO NOT** tow the product by mounting on truck bed or any other moving object. This may cause personal injury or product damage. Mounting this product on any vehicle in any

manner will void warranty.

- Use as intended only. Do not use for food preparation.
- **DO NOT** alter this product in any manner. For example, do not weld external lock bars or attach electrical equipment.
- Inspect before every use; do not use if parts are loose or damaged.
- Maintain product labels and nameplates. These carry important safety information. If unreadable or missing, Call us at **847-327-0566** or **844-YARDMAX**, email us at **info@shopmax.com** for a replacement.

ELECTRIC SAFETY

DANGER ⚠

Follow all manufacturer's warnings and operating instructions about electric safety.

- **DO NOT** use in an explosive atmosphere. Grounding required.
- Chest/Cabinet plugs must match the outlet.
- Never modify the plug in any way.
- **DO NOT** use any adapter plugs with earth (grounded) chest power strips.
- Unmodified plugs and matching outlets will reduce the risk of electric shock.
- Electrical shock hazard. Do not plug the cord into the outlet if your hands are wet. Do not use this product near a bathtub, a shower, or a swimming pool. Make sure all cords are unplugged before any servicing or cleaning. Follow manual for recommended usage.
- Avoid body contact with earthed or grounded surfaces. There is an increased risk of electric shock if your body is earthed or grounded.
- **DO NOT** insert extension cord through the hole without grommet in place.
- Check the insulation and plugs of extension cord before using. **DO NOT** use cord if it is worn or damaged.
- Only use a three-wire extension cord with all three prongs intact. Never remove the round grounding prong.
- Extension cord must be connected to a 125 Volt GFCI protected outlet with proper ground. If GFCI outlet is not available, use an extension cord with GFCI protection built in.
- **DO NOT** overload extension cord.
- Remove extension cord from the hole before moving or transporting storage chest/cabinet/work station.
- Only use an extension cord that is rated for outdoor use.
- **DO NOT** connect an extension cord to outlet that also supplies critical safety equipment with power.

CAUTION ⚠

RISK OF ELECTRICAL SHOCK: Make sure all cords are unplugged before any servicing or cleaning.

WARNING ⚠

Changes or modifications to this unit not expressly approved by the party responsible for compliance could void the user's authority to operate the equipment.

NOTE ⓘ

This device complies with Part 15 of the FCC Rules. Operation is subject to the following two conditions:

- (1) this device may not cause harmful interference, and
- (2) this device must accept any interference received, including interference that may cause undesired operation.

NOTE ⓘ

This equipment has been tested and found to comply with the limits for a Class B digital device, pursuant to Part 15 of the FCC Rules. These limits are designed to provide reasonable protection against harmful interference in a residential installation. This equipment generates, uses and can radiate radio frequency energy and, if not installed and used in accordance with the instructions, may cause harmful interference to radio communications. However, there is no guarantee that interference will not occur in a particular installation.

If this equipment does cause harmful interference to radio or television reception, which can be determined by turning the equipment off and on, the user is encouraged to try to correct the interference by one or more of the following measures:

- Reorient or relocate the receiving antenna.
- Increase the separation between the equipment and receiver.
- Connect the equipment into an outlet on a circuit different from that to which the receiver is connected.
- Consult the dealer or an experienced radio/TV technician for help.

UNPACKING THE CONTAINER

Use scissors or a knife to cut all the straps. Lift off the carton and dispose of properly. (See Figure 1 & 2)

Figure 1

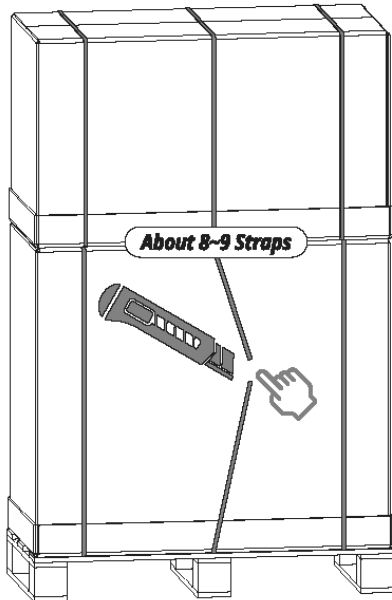
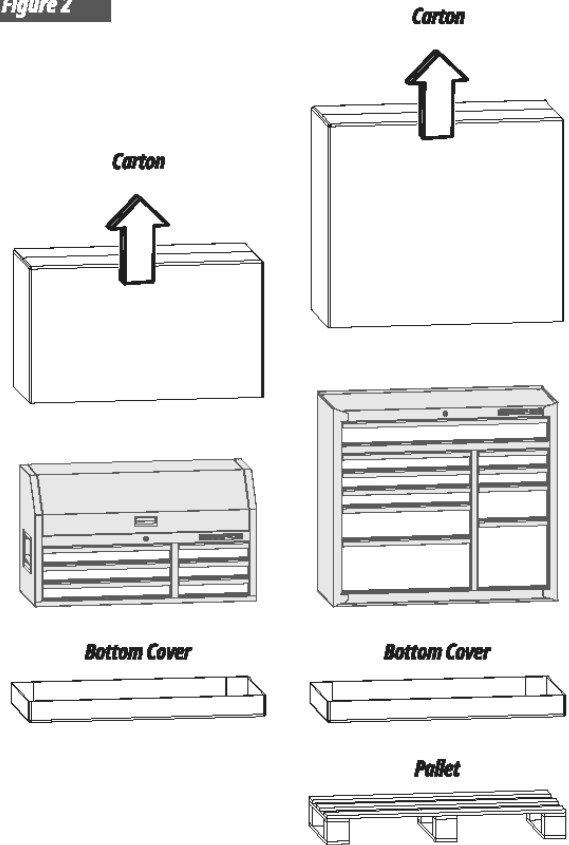

Figure 2



CONTENTS SUPPLIED

Your SHOPMAX product comes partially assembled and contains the following:

Package Content of the Top Tool Chest

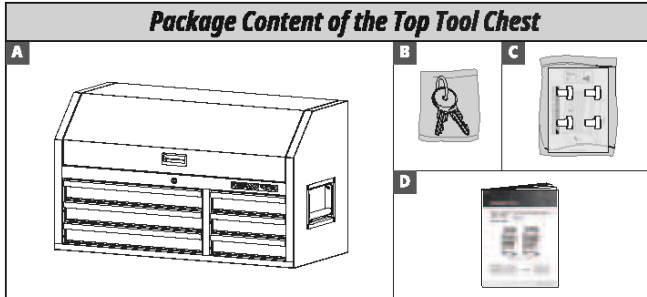

Package Content of the Rolling Tool Cabinet

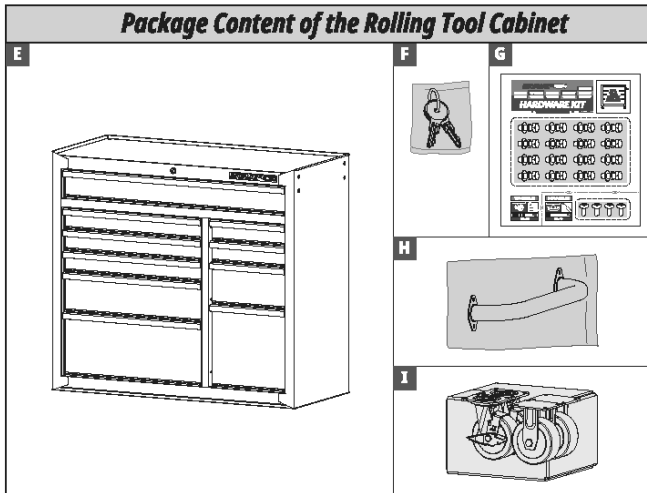

No.	Description	Qty.
A	Top Tool Chest	1
B	Keys for the Top Chest (Inside the top lid)	2
C	Foot Pin of the Top Chest (Inside the top lid)	4
D	Operator's Manual (Inside the top lid)	1
E	Rolling Tool Cabinet	1
F	Keys for the Rolling Cabinet (Inside the top drawer of the cabinet)	2
G	Hardware Kit of the Rolling Cabinet (Inside the top drawer of the cabinet)	1
H	Cabinet Side Handle (Inside the bottom drawer of the cabinet)	1

I	Casters (Inside the bottom drawer of the cabinet)	4
---	---	---

Hardware Kit, Included:

Part	Description	Quantity
	Bolt M8 x 25	16
	Washer 8	16
	Spring Washer 8	16
	Screw M6 x 16	4
	Foot Pin	4

Recommended Tools

To assemble your SHOPMAX Chest/Cabinet, you will need a 14 mm wrench, and a phillips screwdriver.

Part	Description
	14 mm Wrench
	Phillips Screwdriver

NOTE

Tools Needed for Assembly, not Supplied.

ASSEMBLY

CAUTION ⚠

Two people are recommended for assembly.

BOTTOM CABINET

Cabinet Side Handle Installation

Position the cabinet side handle over the holes on the cabinet. Attach with the four screws and tighten with a Phillips screwdriver (not supplied).

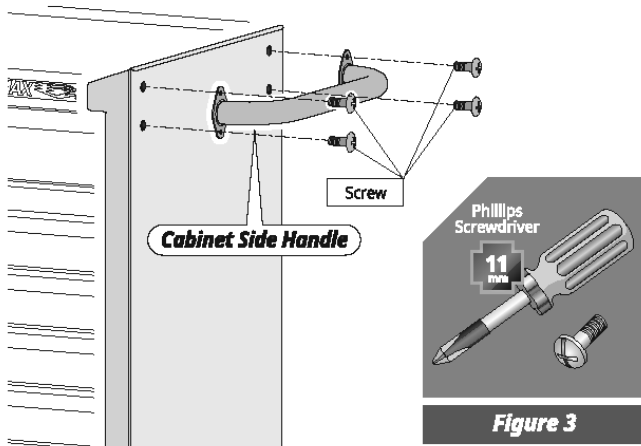

Figure 3

Casters Installation

1. Be sure the drawers are locked and lay the cabinet on its backside. Using packing material to protect the unit.
2. Attach the two locking swivel casters to the cabinet, on the same side as the cabinet side handle, tighten with bolts, spring washers and flat washers.

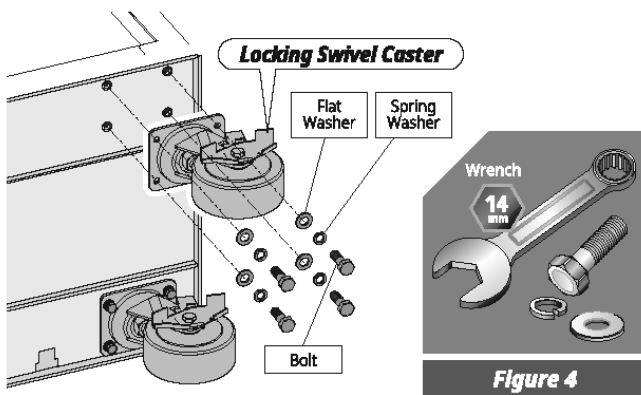

Figure 4

3. Repeat to install the two static casters on the opposite side of the cabinet.

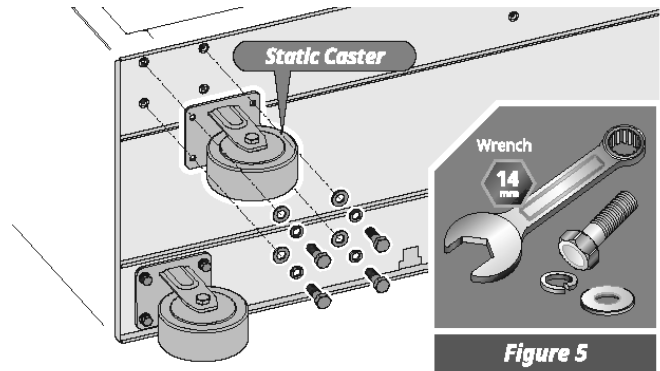

Figure 5

TOP CHEST

Foot Pin Installation

Press in the four foot pins into the bottom of the top chest.

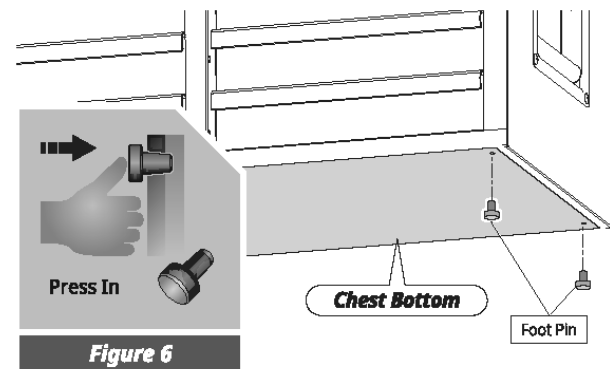

Figure 6

Final Assembly

Using an assistant, place empty top chest on the top of the cabinet.

WARNING ⚠

Make sure the top chest is seated inside the bottom cabinet's edges.

OPERATIONS

WARNING

For safety, evenly distribute the weight of tools between all drawers. The even distribution will prevent the unit from becoming top-heavy and accidentally tipping when a drawer is opened.

GENERAL OPERATION

1. Empty all drawers.
2. Close all drawers and lock them.
3. Unlock swivel casters.
4. To prevent tipping, move using the handle on the bottom cabinet only. Roll cabinet to a flat, level, hard and smooth surface capable of safely supporting a fully loaded cabinet. Do not roll the cabinet over concrete seams or other rough/uneven surfaces.
5. Lock swivel casters.
6. Unlock drawers and fill them evenly, from bottom to top. Do not exceed weight capacities.

REMOVE THE DRAWER

1. Empty the drawer.
2. Fully extend the drawer.
3. Push the lever on the right slide down, lift the lever on the left side up. Pull out drawer to remove (See Figure 7a & 7b).

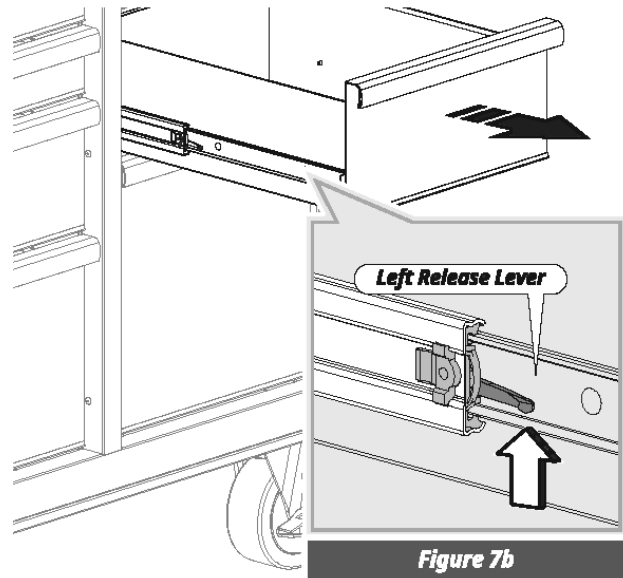
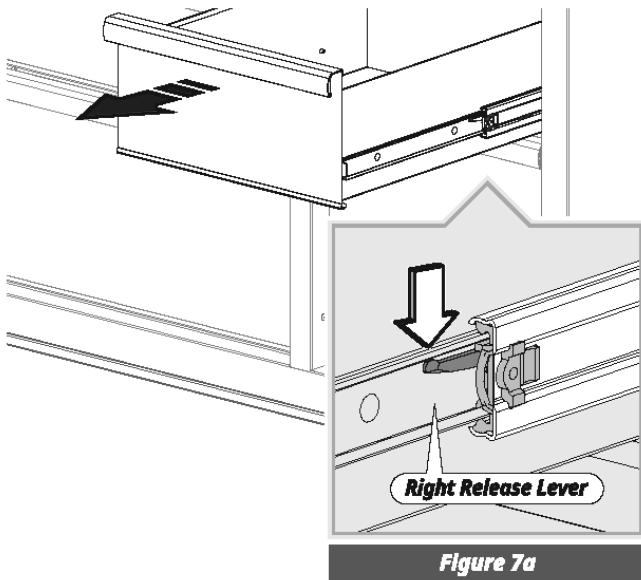

INSTALL THE DRAWER

1. Pull slides and slide carrier out to a fully extended position (See Figure 8a).
2. Hold the slide on the cabinet while aligning it with the slide on drawer.
3. Slightly insert one side and repeat for the other side. Slowly push the drawer to its fully closed position to engage the slide.
4. Open drawer and reclose to ensure proper operation.

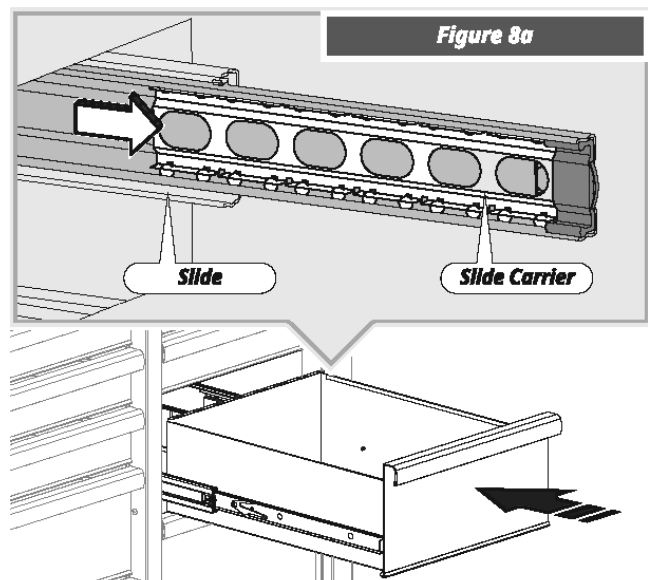

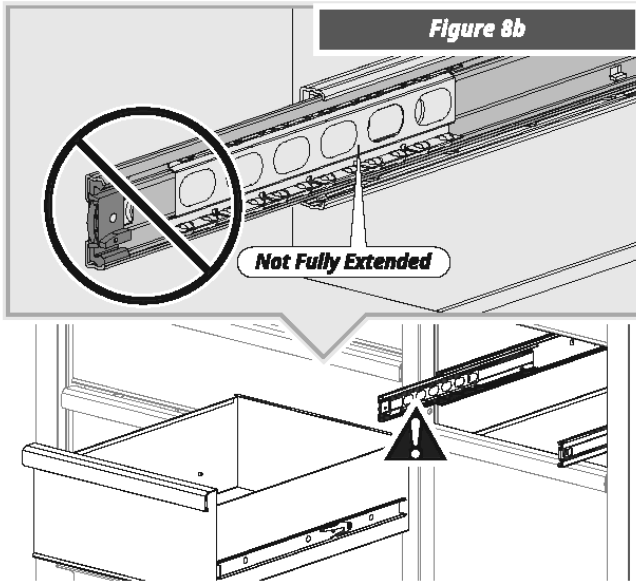

USING THE CASTER BRAKES

To lock the swivel casters, step down on the lever marked ON. Be sure to lock all four swivel casters to prevent the chest/cabinet from rolling. To unlock casters, push down on the levers marked OFF.

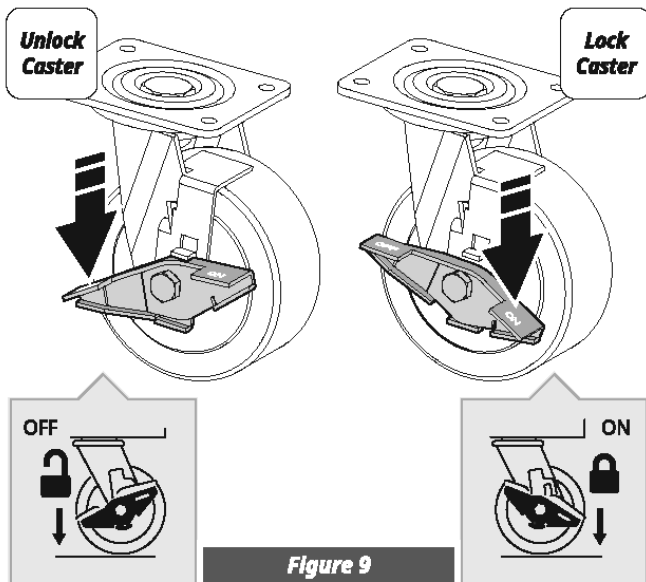
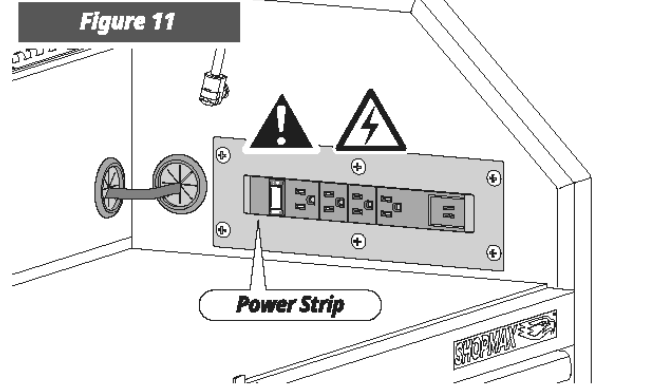
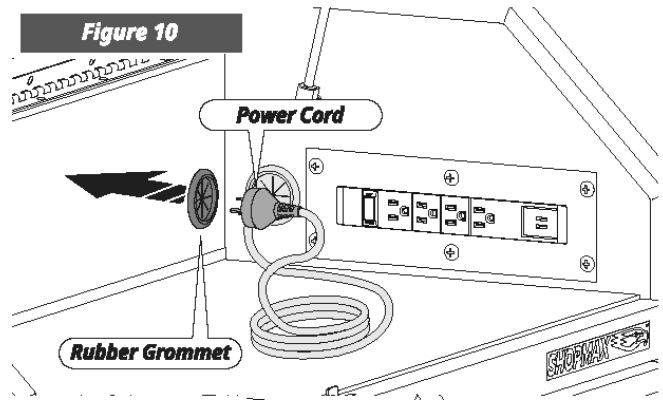

Figure 9

POWER STRIP

Passing cords through the rubber grommet. Be sure to follow all electrical safety precautions.



Part	Description
Electric Outlets	4 Electric Outlets 120V~ 60Hz, 15Amp, 1875Walt (Total Power)
USB Slots	2 USB Slots, DC 5V, Max 2.1A
Punch-outs / Rubber Grommets	1 additional rubber grommets (94106R2 - 10S7) 2 additional rubber grommets (93606C2 - 06A4)

DANGER ⚠

- DO NOT use in explosive atmosphere. Grounding required.
- Electrical shock hazard. Do not plug cord into the outlet if your hands are wet.
- Do not use this product near a bathtub, a shower, or a swimming pool.

MANTENANCE

WARNING

Procedures not specifically explained in this manual must be performed only by a qualified technician.

WARNING

To prevent serious injury from tool failure, do not use damaged equipment. If any part becomes damaged, have the problem corrected before further use.

PERIODICAL INSPECTION

- Loose hardware.
- Misalignment or binding of moving parts.
- Brake operation.
- Caster swivel function and movement.
- Cracked or broken parts.
- Any other condition that may affect its safe operation.

CLEAN

- Use mild detergent and water to clean drawer fronts, drawer trim and the other surfaces.
- Grease and oil can be removed with standard, non-abrasive, nonflammable cleaning products.

LUBRICATION

Casters

Lubricate the casters once a year with high quality ball bearing grease. This may be required more often if operating the tool box in colder climates.

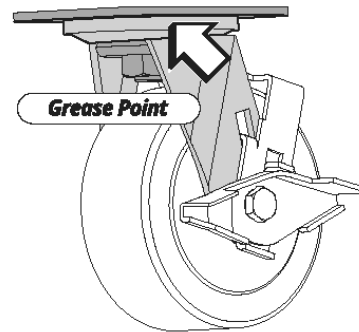

Figure 12

Slides

Lubricate the slides semi-annually with high quality, petroleum-based lubricant. This may be required more often if operating the tool box in colder climates.

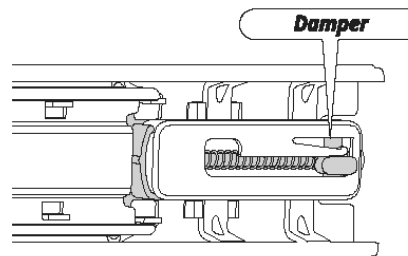
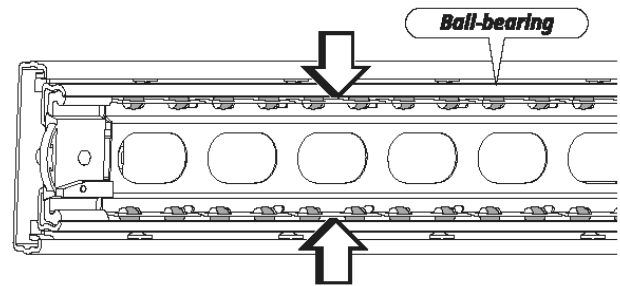
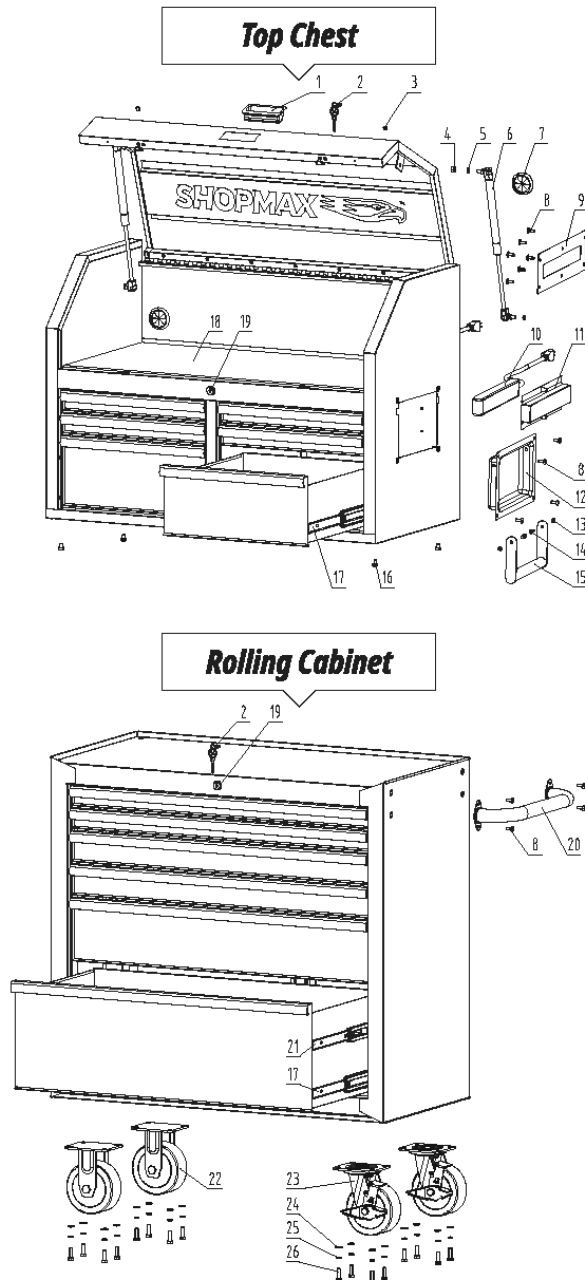

Figure 13

PARTS DIAGRAM

93606C2-06A4 EXPLODED VIEWS

93606C2-06A4 (Combo)
 993606C2 (Chest)
 953606A4 (Cabinet)



93606C2-06A4 PART LISTS

No.	Description	Qty.
1	Top Cover Plastic Handle	1
2	Key (2 pieces)	4
3	Cushion	2
4	Nut M8	2
5	Spring Washer 8	4
6	Gas-shock Lid Strut	2
7	Rubber Ring for Threading Wire	3
8	Cross Recessed Flat Round Head Screw M6x16	18
9	Outlet Panel Cover	1
10	Outlet	1
11	Outlet Box	1
12	Fold-out Side Handle Bottom Plate	2
13	Lock Nut M5	4
14	Slotted Spherical Cylindrical Head Axle Position Screw M5x6	4
15	Fold-out Side Handle	2
16	Foot Pin	4
17	Drawer Slide (Secure Latch Retention)	24
18	Top Chest Liner	1
19	Lock	2
20	Cabinet Side Handle	1
21	Drawer Slide	2
22	Static Caster-5"x2"	2
23	Swivel Caster-5"x2"	2
24	Washer 8	16
25	Spring Washer 8	16
26	Bolt M8x25	16

Exploded View & Parts Lists -



94106R2-10S7 EXPLODED VIEWS

94106R2-10S7 (Combo)

994106R2 (Chest)

954110S7 (Cabinet)

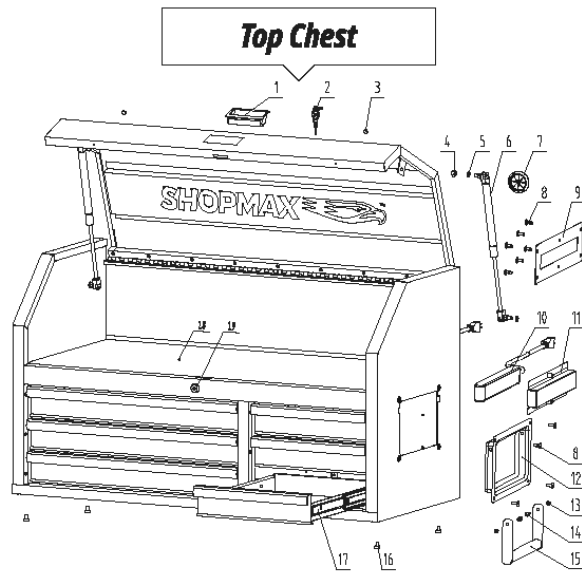

Rolling Cabinet

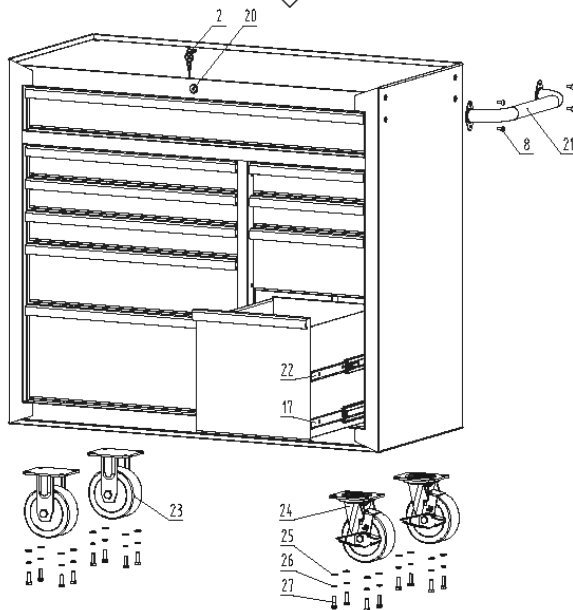

94106R2-10S7 PART LISTS

No.	Description	Qty.
1	Top Cover Plastic Handle	1
2	Key (2 pieces)	4
3	Cushion	2
4	Nut M8	2
5	Spring Washer 8	4
6	Gas-shock Lid Strut	2
7	Rubber Ring for Threading Wire	2
8	Cross Recessed Flat Round Head Screw M6x16	18
9	Outlet Panel Cover	1
10	Outlet	1
11	Outlet Box	1
12	Fold-out Side Handle Bottom Plate	2
13	Lock Nut M5	4
14	Slotted Spherical Cylindrical Head Axle Position Screw M5x6	4
15	Fold-out Side Handle	2
16	Foot Pin	4
17	Drawer Slide (Secure Latch Retention)	32
18	Top Chest Liner	1
19	Lock	1
20	Lock	1
21	Cabinet Side Handle	1
22	Drawer Slide	4
23	Static Caster-5"x2"	2
24	Swivel Caster-5"x2"	2
25	Washer 8	16
26	Spring Washer 8	16
27	Bolt M8x25	16

WARRANTY

WARRANTY INFO

The warranty set forth below is given by YARDMAX with respect to new merchandise purchased and used in the United States and/or its territories and possessions. YARDMAX warrants its product, subject to limitations and exclusions below, against defects in material and workmanship for a period of three (3) years commencing on the date of original purchase, and will, at its discretion, repair or replace, free of charge to the customer, any part found to be defective in material or workmanship when the product is solely used for residential purposes during the three (3) year period.

LIMITATIONS AND EXCLUSIONS

YARDMAX's warranty does not cover normal wear and tear, neglect, accident, improper assembly, improper maintenance, modification, alteration, improper repair, use of parts not approved by YARDMAX or product damage due to misuse by the customer. Replacement of products or parts due to normal wear and tear is the responsibility of the customer. Proof of original purchase is required. The warranty is non-transferrable. This limited warranty shall only apply if the product has been assembled, operated, and maintained in accordance with Owner's Manual supplied with the product. No Implied Warranty, including any implied warranty of merchantability or fitness for a particular purpose, applies after the expiration of the applicable period of express written warranty provided above. No other express warranty, whether written or oral, except mentioned herein, given by any person or entity, including a dealer or retailer, with respect to any product, shall bind YARDMAX. The provisions as set forth herein in this warranty provide the sole and exclusive remedy arising from the sale. YARDMAX shall not be liable for incidental or consequential damages to the extent allowable by law. The customer may have other rights not disclosed herein; and they may vary from state to state.

Have questions about your SHOPMAX equipment?

Call us at 847-327-0566 or 844-YARDMAX, email us at info@shopmax.com.



Your Tools. Your Shop.™

