



41" / 46" / 52" Mobile Workstation OPERATOR'S MANUAL



Model: 964106R5



Model: 964609G7



Model: 965209S5



Model: 965211S5

Some instructions and drawings may not apply to your specific unit.

SERIAL NUMBER

PURCHASE DATE

Both model number and serial number may be found on the carton. You should record both of them in a safe place for future use.

WARNING 







Carefully read and understand this entire operator's manual before installing and using this product. Pay attention to all the cautions and warnings.







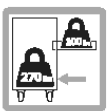
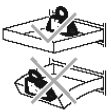

SPECIFICATIONS

Model	Drawer Slide Weight Rating	Weight Capacity
964106R5	100 lbs	1000 lbs
964609G7	100 lbs	1200 lbs
965209S5	100 lbs	1200 lbs
965211S5	100 lbs	1200 lbs

SYMBOLS

The labels on your product may show symbols. These represent important information about the product or instructions on its use.

	Read and follow all safety rules and operating instructions.
	Keep wheels locked when not moving this product. This will prevent the product from rolling.
 	Close and lock drawers before moving this cabinet.
	Keep children and bystanders off and away.
	Do not fully open a drawer loaded to full capacity unless the closed drawers contain a total of at least 270 pounds of content.
	Distribute contents of loaded drawers evenly. Load drawers starting in the back first and load forward as needed.
	DO NOT drag while moving – always push.

	Keep the product on level surfaces.
	DO NOT step in the drawers.
	Do not stand on this product.
	DO NOT open more than one drawer at a time.
	Never exceed maximum weight capacity for each drawer or shelf.
	DO NOT drop heavy objects into drawers or push down on open drawers.
	DO NOT exceed the maximum height capacity for each drawer or shelf.
	Be careful when closing drawers or doors. Remove hands before drawers or doors close completely.

SAFETY

SIGNAL SAFETY WORDS DEFINITION

The definitions below give the level of severity for each signal word.

DANGER

This symbol is used to indicate a hazardous situation which, if not avoided, will result in serious injury or death.

WARNING

This symbol points out safety instructions. Read and follow all instructions before attempting to operate this product. Failure to comply with these instructions could result in serious injury or death.

CAUTION

This symbol indicates a hazard, which, if not avoided, may result in minor injury, moderate injury, or property damage.

NOTE

This information makes the product easier to use.

ASSEMBLY SAFETY

WARNING

- Assemble only according to these instructions. Improper assembly can create hazards.
- Wear ANSI-approved safety goggles and heavy-duty work gloves during assembly.
- Keep assembly area clean and well lit.
- Keep bystanders out of the area during assembly.
- **DO NOT** assemble when tired or when under influence of alcohol, drugs or medication.
- Weight capacity and other product capacities apply to properly and completely assembled product only.
- Assemble on a flat, level, hard and smooth surface capable of safely supporting a fully loaded workstation.

OPERATION SAFETY

DANGER

- **DO NOT** sit, stand or climb on this unit.
- This product is not a toy nor a toy chest. Do not allow children to play with or near this item.
- Be aware of dynamic loading! Sudden load movement may briefly create excess load causing product failure. Do not exceed capacity of the bench or shelf supporting Top Chest.
- **DO NOT** open more than one drawer at once. This workstation may become unstable and tip over causing personal injury and/or product damage.
- Be careful when closing the drawers, the cover or doors. Remove hands before the cover/drawer/door close completely to prevent personal injury.

WARNING

- Make sure the lid lock or drawer lock is in the unlocked position before closing the lid or drawer. Failure to do so could result in a defective lock system and/or personal injury.
- Before locking, make sure the drawers are completely closed in order for lock system to work properly.
- Empty, close, and lock drawers before moving.
- **DO NOT** pull this product, push it when moving. Pushing the unit will prevent serious ankle and foot injuries.
- **DO NOT** move the item after stacking the top chest on the bottom workstation, it could cause the chest to topple.
- Use only on flat, level, hard and smooth surface capable of safely supporting a fully loaded Workstation. Do not roll Workstation over concrete seams or other rough/uneven surfaces.
- **DO NOT** move or lift while loaded. Do not lift using handle(s).
- **DO NOT** lift workbench by wood top. Wood top may separate causing injury.
- **DO NOT** lift this product directly with a forklift or tow with any mechanical devices.
- To prevent tipping, move using supplied handle on Bottom the item only.
- Apply caster brakes unless moving the item.
- Secure this product properly before moving it with a forklift.

- **DO NOT** tow the product by mounting on truck bed or any other moving object. This may cause personal injury or product damage. Mounting this product on any vehicle in any manner will void warranty.
- Use as intended only. Do not use for food preparation.
- **DO NOT** alter this product in any manner. For example, do not weld external lock bars or attach electrical equipment.
- Inspect before every use; do not use if parts are loose or damaged.
- Maintain product labels and nameplates. These carry important safety information. If unreadable or missing, Call us at **847-327-0566** or **844-YARDMAX**, email us at **info@shopmax.com** for a replacement.

UNPACKING THE CONTAINER

Use scissors or a knife to cut all the straps. Lift off the carton and dispose of properly. (See Figure 1 & 2)

Figure 1

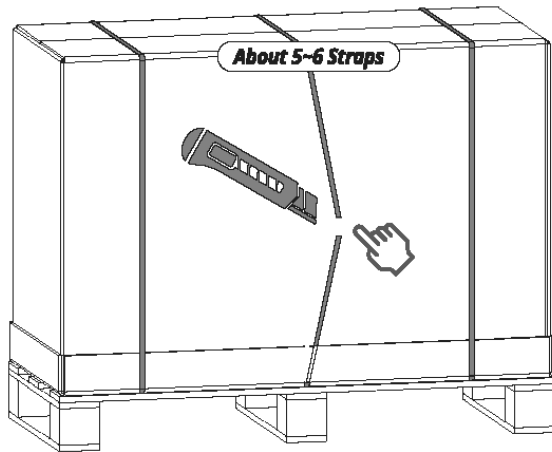
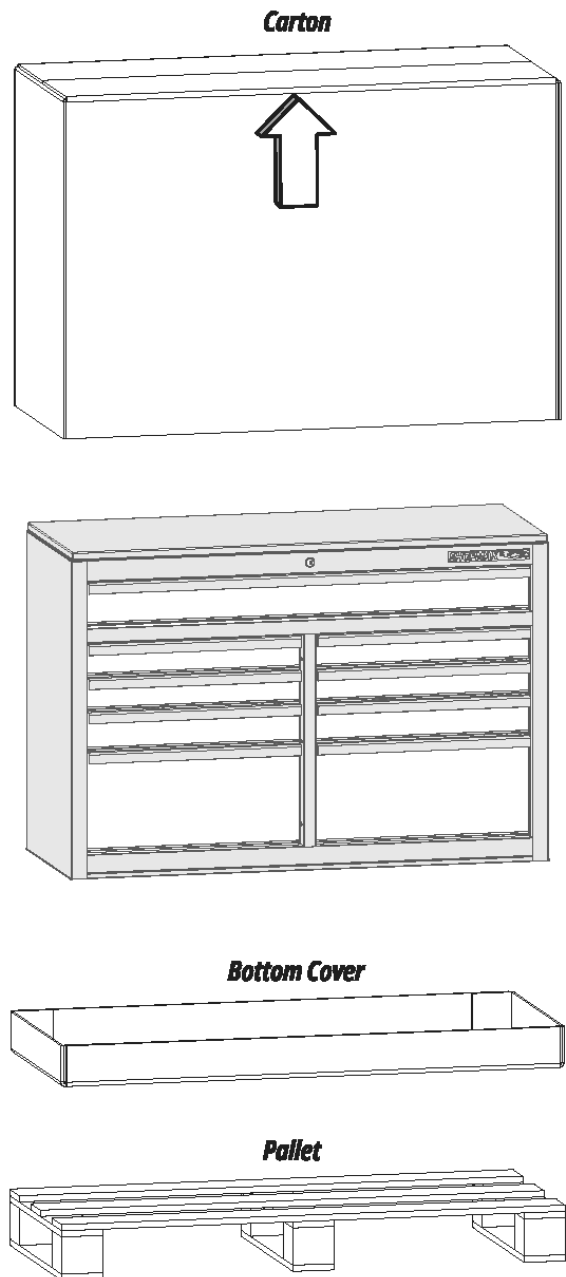
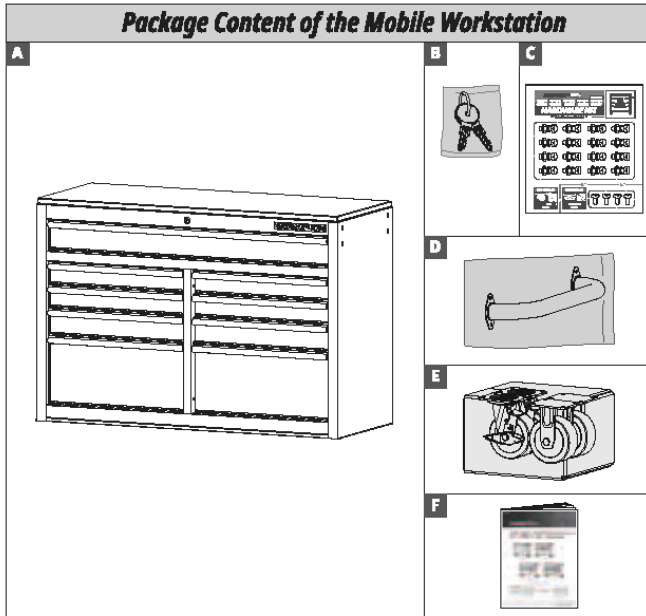

Figure 2







CONTENTS SUPPLIED

Your SHOPMAX product comes partially assembled and contains the following:

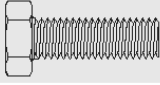

No.	Description	Qty.
A	Mobile Workstation	1
B	Keys (Inside the top drawer)	2
C	Hardware Kit (Inside the top drawer)	1
D	Side Handle (Inside the bottom drawer)	1
E	Casters (Inside the bottom drawer)	4
F	Operator's Manual (Inside the top drawer)	1

Hardware Kit, Included:

Part	Description	Quantity
	Bolt M8 x 25	16
	Washer 8	16
	Spring Washer 8	16
	Screw M6 x 16	4

Recommended Tools

To assemble your SHOPMAX Workstation, you will need a 14 mm wrench, and a phillips screwdriver.

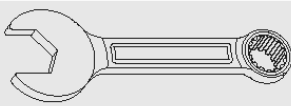
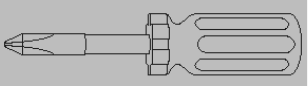
Part	Description
	14 mm Wrench
	Phillips Screwdriver

NOTE

Tools Needed for Assembly, not Supplied.

ASSEMBLY

CAUTION

Two people are recommended for assembly.

SIDE HANDLE INSTALLATION

Position the side handle over the holes on the workstation. Attach with the four screws and tighten with a phillips screwdriver (not supplied).

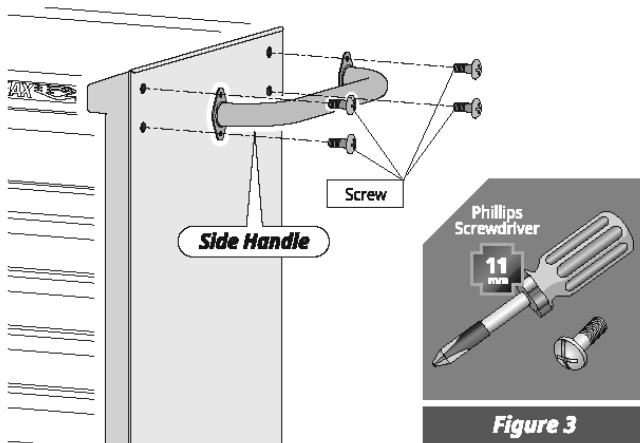

CASTERS INSTALLATION

1. Be sure the drawers are locked and lay the workstation on its backside. Using packing material to protect the unit.
2. Attach the two locking swivel casters to the bottom of the workstation, on the same side as the side handle, tighten with bolts, spring washers and flat washers.

NOTE

Make sure to install both locking swivel casters on the handle side of workbench.

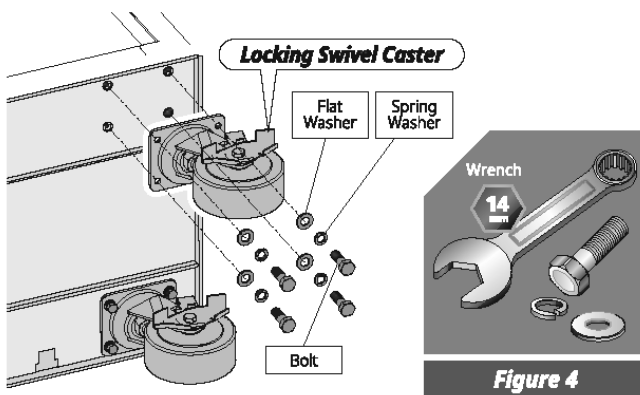

3. Repeat to install the two static casters on the opposite side of the workstation.

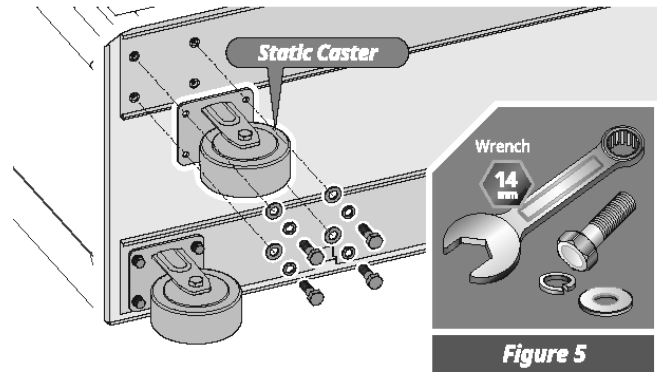

OPERATIONS

WARNING

For safety, evenly distribute the weight of tools between all drawers. The even distribution will prevent the unit from becoming top heavy and accidentally tipping when a drawer is opened.

GENERAL OPERATION

1. Empty all drawers.
2. Close all drawers and lock them.
3. Unlock swivel casters.
4. To prevent tipping, move using the side handle only. Roll workstation to a flat, level, hard and smooth surface capable of safely supporting a fully loaded the workstation. Do not roll workstation over concrete seams or other rough/uneven surfaces.
5. Lock swivel casters.
6. Unlock drawers and fill them evenly, from bottom to top. Do not exceed weight capacities.

REMOVE THE DRAWER

1. Empty the drawer.
2. Fully extend the drawer.
3. Push the lever on the right slide down, lift the lever on the left side up. Pull out drawer to remove (See Figure 6a & 6b).

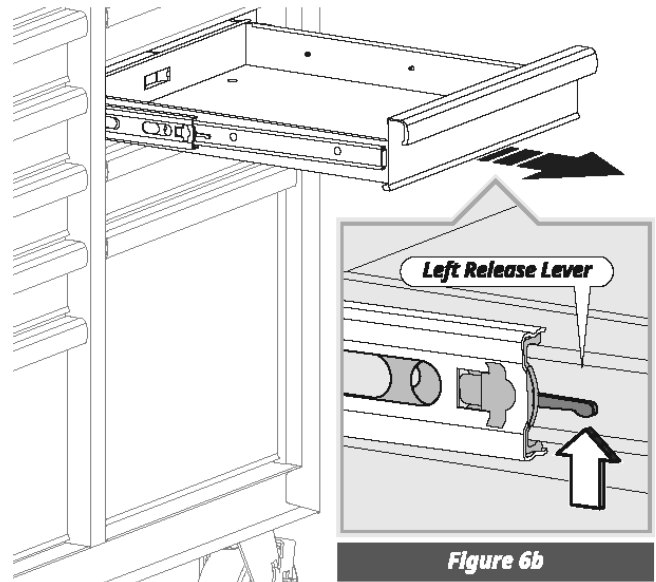
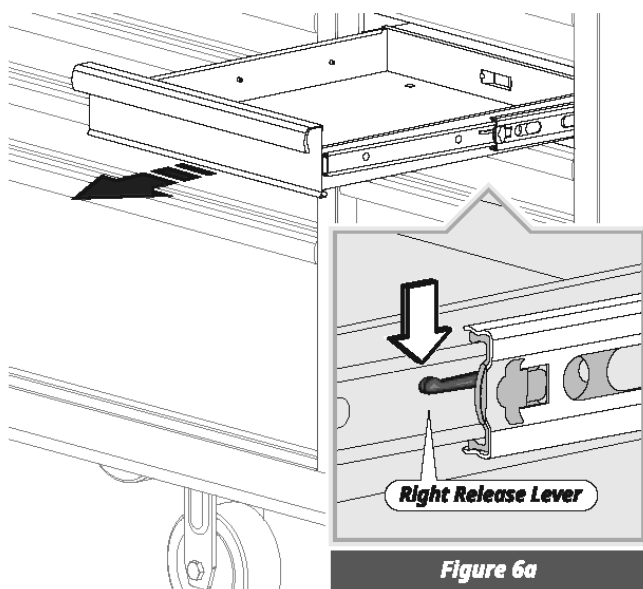

INSTALL THE DRAWER

1. Pull slides and slide carrier out to a fully extended position (See Figure 7a).
2. Hold the slide on the workstation while aligning it with the slide on drawer.
3. Slightly insert one side and repeat for the other side. Slowly push the drawer to its fully closed position to engage the slide.
4. Open drawer and reclose to ensure proper operation.

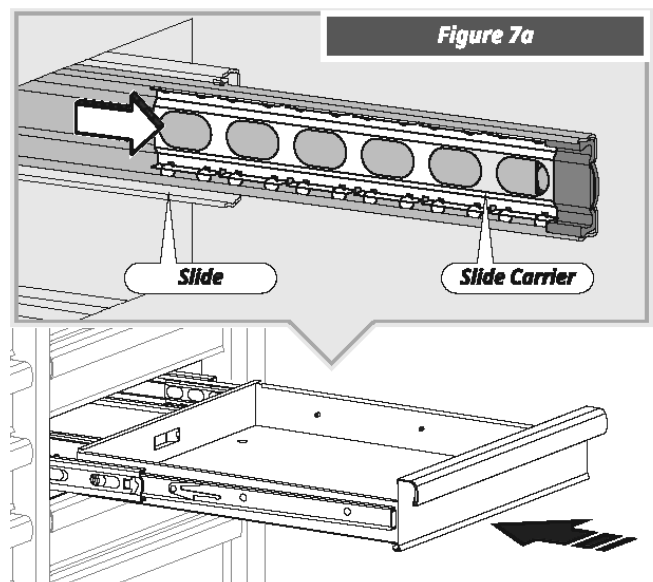

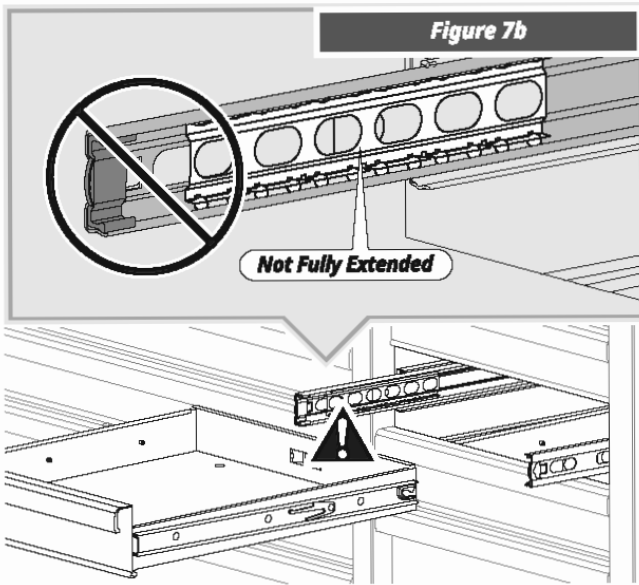

USING THE CASTER BRAKES

To lock the swivel casters, step down on the lever marked ON. Be sure to lock all four swivel casters to prevent the workstation from rolling. To unlock casters, push down on the levers marked OFF.

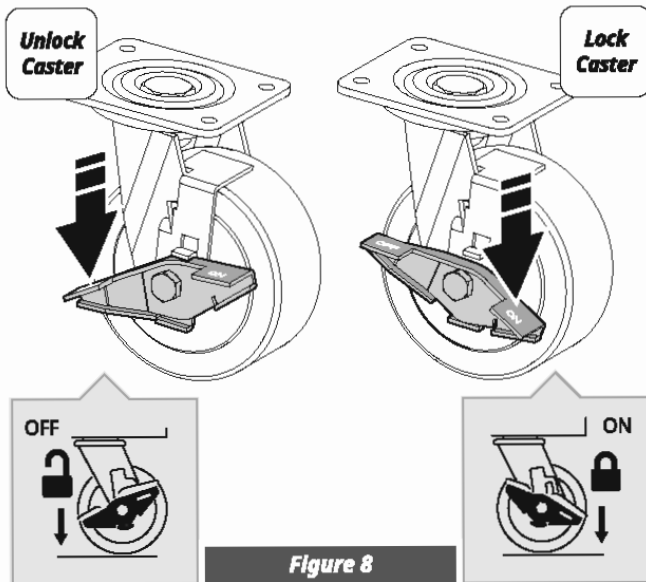

MANTENANCE

WARNING ⚠

Procedures not specifically explained in this manual must be performed only by a qualified technician.

WARNING ⚠

To prevent serious injury from tool failure, do not use damaged equipment. If any part becomes damaged, have the problem corrected before further use.

PERIODICAL INSPECTION

- Loose hardware.
- Misalignment or binding of moving parts.
- Brake operation.
- Caster swivel function and movement.
- Cracked or broken parts.
- Any other condition that may affect its safe operation.

CLEAN

- Use mild detergent and water to clean drawer fronts, drawer trim and the other steel surfaces. Avoid harsh, abrasive cleaners, and other corrosive chemicals.
- Grease and oil can be removed with standard, non-abrasive, nonflammable cleaning products.
- Keep dry and avoid damp environments.
- Wood top can be cleaned with damp cloth and wiped dry immediately with dry cloth. If needed, solvent-based wood furniture cleaner can be used.
- Clean up any spills immediately to prevent stains from forming on the wood top.

LUBRICATION

Casters

Lubricate the casters once a year with high quality ball bearing grease. This may be required more often if operating the tool box in colder climates.

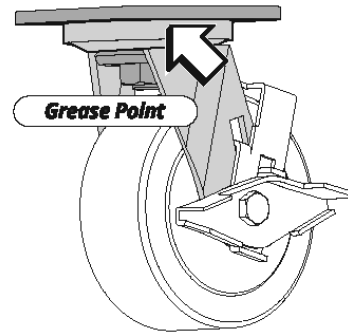

Slides

Lubricate the slides semi-annually with high quality, petroleum-based lubricant. This may be required more often if operating the tool box in colder climates.

Secure Latch Retention Drawer Slide for 964106R5 & 964609G7

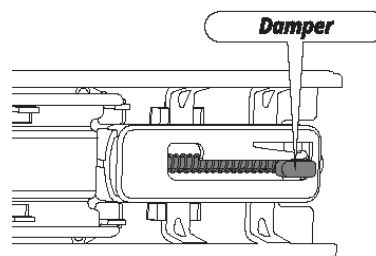
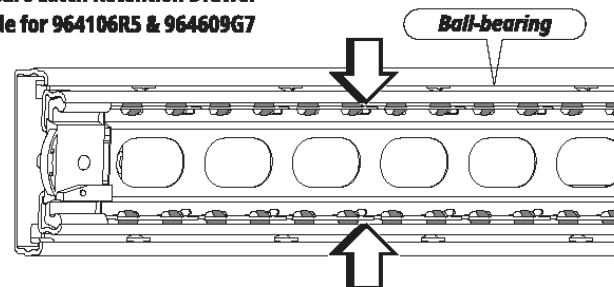

**Soft Close Drawer Slide for
96520955 & 96521155**

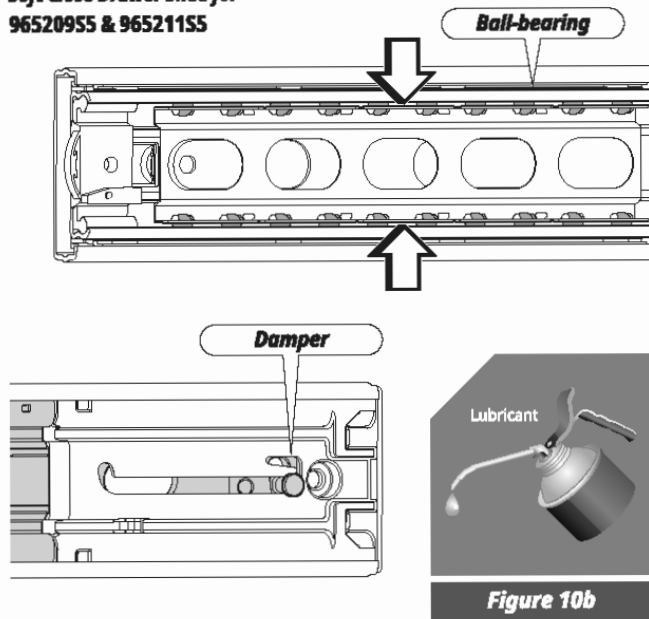

PARTS DIAGRAM

964106R5 EXPLODED VIEWS

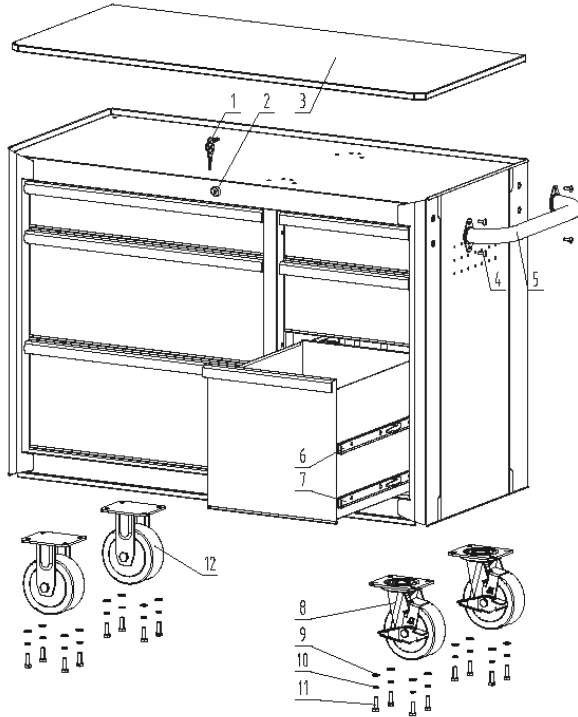

964106R5 PART LIST

No.	Description	Qty.
1	Key (2 pieces)	2
2	Lock	1
3	Wooden Top	1
4	Cross Recessed Flat Round Head Screw M6x16	4
5	Side Handle	1
6	Drawer Slide	6
7	Drawer Slide (Secure Latch Retention)	12
8	Swivel Caster-5"x2"	2
9	Washer 8	16
10	Spring Washer 8	16
11	Bolt M8x25	16
12	Static Caster-5"x2"	2

964609G7 EXPLODED VIEWS

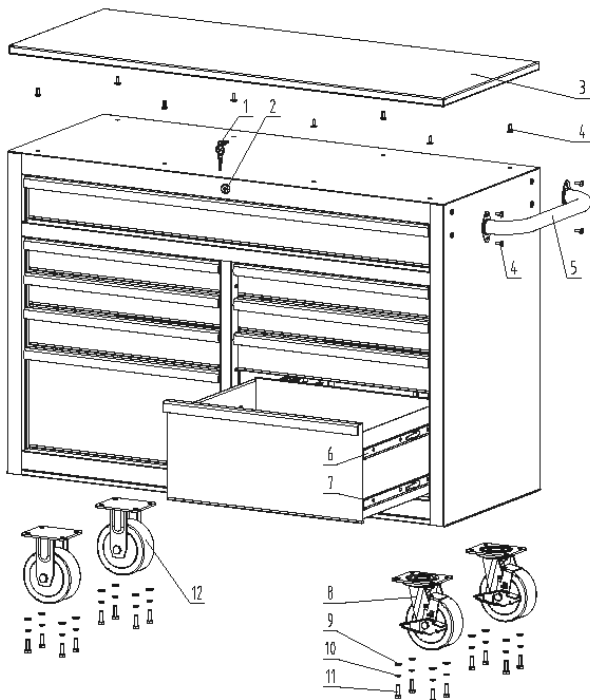

964609G7 PART LIST

No.	Description	Qty.
1	Key (2 pieces)	2
2	Lock	1
3	Wooden Top	1
4	Cross Recessed Flat Round Head Screw M6x16	12
5	Side Handle	1
6	Drawer Slide	5
7	Drawer Slide (Secure Latch Retention)	22
8	Swivel Caster-5"x2"	2
9	Washer 8	16
10	Spring Washer 8	16
11	Bolt M8x25	16
12	Static Caster-5"x2"	2

Exploded View & Parts Lists -

965209S5 EXPLODED VIEWS

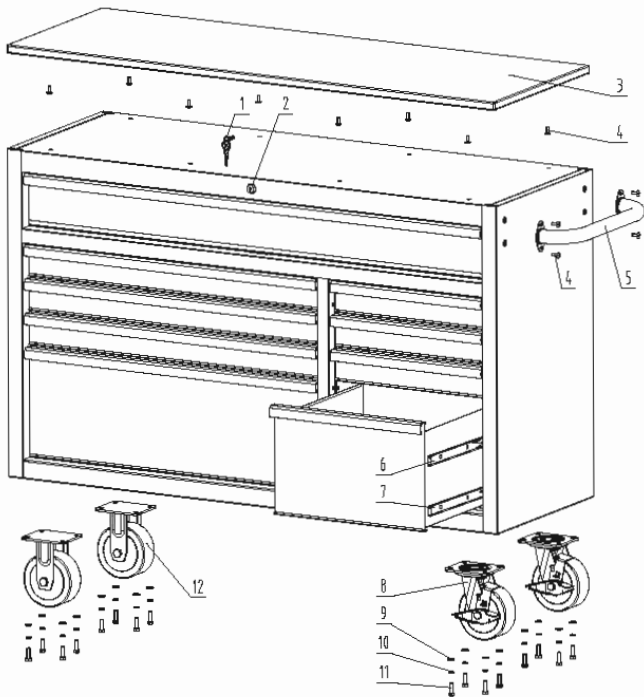

965209S5 PART LIST

No.	Description	Qty.
1	Key (2 pieces)	2
2	Lock	1
3	Wooden Top	1
4	Cross Recessed Flat Round Head Screw M6x16	12
5	Side Handle	1
6	Drawer Slide	5
7	Drawer Slide (Soft Close)	18
8	Swivel Caster-5"x2"	2
9	Washer 8	16
10	Spring Washer 8	16
11	Bolt M8x25	16
12	Static Caster-5"x2"	2

965211S5 EXPLODED VIEWS

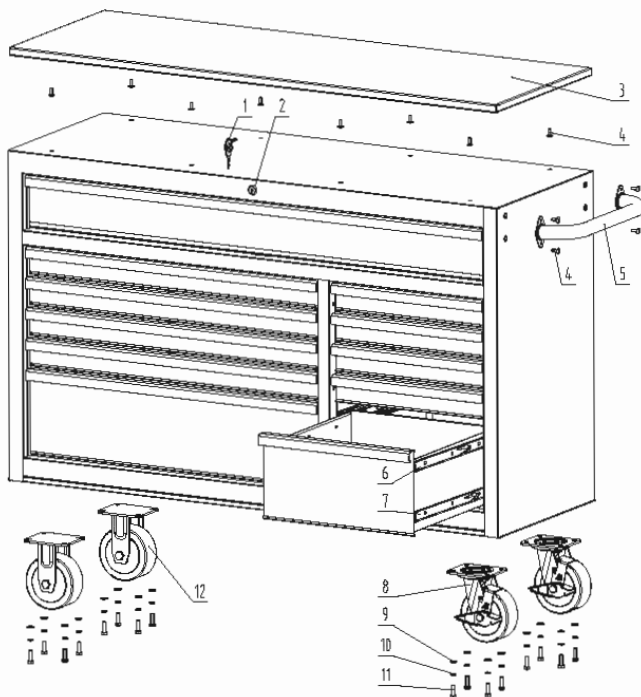

965211S5 PART LIST

No.	Description	Qty.
1	Key (2 pieces)	2
2	Lock	1
3	Wooden Top	1
4	Cross Recessed Flat Round Head Screw M6x16	12
5	Side Handle	1
6	Drawer Slide	5
7	Drawer Slide (Soft Close)	22
8	Swivel Caster-5"x2"	2
9	Washer 8	16
10	Spring Washer 8	16
11	Bolt M8x25	16
12	Static Caster-5"x2"	2

Exploded View & Parts Lists - 

WARRANTY

WARRANTY INFO

The warranty set forth below is given by YARDMAX with respect to new merchandise purchased and used in the United States and/or its territories and possessions. YARDMAX warrants its product, subject to limitations and exclusions below, against defects in material and workmanship for a period of three (3) years commencing on the date of original purchase, and will, at its discretion, repair or replace, free of charge to the customer, any part found to be defective in material or workmanship when the product is solely used for residential purposes during the three (3) year period.

LIMITATIONS AND EXCLUSIONS

YARDMAX's warranty does not cover normal wear and tear, neglect, accident, improper assembly, improper maintenance, modification, alteration, improper repair, use of parts not approved by YARDMAX or product damage due to misuse by the customer. Replacement of products or parts due to normal wear and tear is the responsibility of the customer. Proof of original purchase is required. The warranty is non-transferrable. This limited warranty shall only apply if the product has been assembled, operated, and maintained in accordance with Owner's Manual supplied with the product. No Implied Warranty, including any implied warranty of merchantability or fitness for a particular purpose, applies after the expiration of the applicable period of express written warranty provided above. No other express warranty, whether written or oral, except mentioned herein, given by any person or entity, including a dealer or retailer, with respect to any product, shall bind YARDMAX. The provisions as set forth herein in this warranty provide the sole and exclusive remedy arising from the sale. YARDMAX shall not be liable for incidental or consequential damages to the extent allowable by law. The customer may have other rights not disclosed herein; and they may vary from state to state.

Have questions about your SHOPMAX equipment?

Call us at 847-327-0566 or 844-YARDMAX, email us at info@shopmax.com.



Your Tools. Your Shop.™

