



41" 6-Drawer Mobile Workstation



Your tools. Your shop.™

Mobile Workstation: 964106R5



Rough, tough, and beautiful

The **SHOPMAX® 6-Drawer Mobile Workstation** stands at the ready to store 12,439 in³ of all your tools and hardware, and to help you reduce the clutter in your garage or work area. Everything about this workstation is designed for heavy usage and maximum storage, starting with an all-welded, 20-ga. steel construction, industrial-strength powdercoated drawer finish, and an outer rough-coat that resists scratching and marking.

Store up to 1,000 lb. in the six drawers — each equipped with ball bearing drawer slides and a secure-latch mechanism that keep the drawers closed when moving. Use the sturdy all-steel side handle to place the cabinet exactly where you need it. Rolls easily on four heavy-duty 5" x 2" casters — two swivel/locking and two static.

- **12,439 in³** total storage space for all your hardware
- **40.87"W x 18.11"D x 34.72"H** combined outside dimensions (w/ top)
- Removable **butcher-block style wood top work surface** w/ durable coating
- **20-gauge steel construction** provides reliability and durability
- **Four 5" x 2" casters**, two swivel/locking and two static
- **100-lb** weight capacity **ball-bearing drawer slides**
- **Secure-latch retention system** keeps drawers closed
- **Industrial strength powdercoat** paint finish resists wear and tear
- **Internal keyed locking system** w/ 2 keys

PRODUCT SPECIFICATIONS*

Product Width / Nominal Width (in.)	40.87 / 41
Product Depth (in.)	18.11
Product Height (in.)	34.72
Product Weight (lb.)	144.4
Weight Grade Rating	Industrial >1000 lb
Steel Frame Thickness (ga.)	20
Drawer Slide Weight Rating (lb.)	100
Weight Capacity (lb.)	1,000
Holding Capacity (cu in.)	12,439
Number of Drawers	6
Drawer #s / Dimensions (in.)	1 / 22.43 x 15.79 x 4.15
(W x D x H)	2-3 / 22.43 x 15.79 x 9.45
	4 / 11.76 x 15.79 x 4.15
	5 / 11.76 x 15.79 x 6.22
	6 / 11.76 x 15.79 x 12.68
Warranty	3-Year Limited

*Preliminary specs, subject to change.

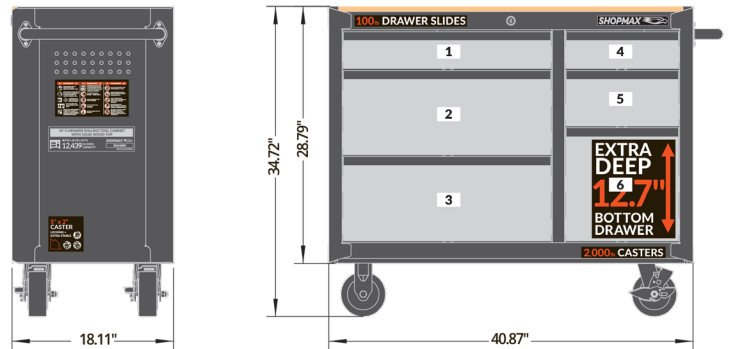

Outside dimensions and drawer numbers

Removable wood top work surface



Store galore & slide some more

If you're looking for organizing and being able to efficiently store your hand tools and other work items, you've got the right workstation. The **secure-latch retention system** (right) on each drawer slide lets you move the workstation around your shop without fear of your drawers coming open.

The extra-tall 12.7" bottom right drawer (left) lets you store – and secure – power hand tools like circular saws, drills, or jig saws.

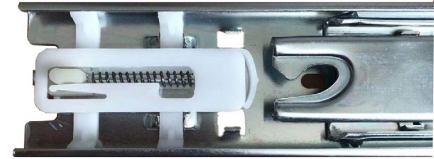

Top it off

The **butcher-block wood top work surface** is durable and never warps, and makes for an ideal project work area.

Move it and hang out

The side of the cabinet features the **sturdy, tubular steel push handle** for moving the workstation. Also has a **perforated pegboard side** (below) that let you hang the tools you use frequently, like screwdrivers, keeping them at the ready for your projects.



2x



2x



5" x 2" heavy-duty casters, two static and two swivel/locking

