

SPORTS AFIELD®

Established 1887



HOME DEFENSE

DROP ACTION BIOMETRIC SECURITY VAULT INSTRUCTION MANUAL FOR SA-HD5-BIO

BIOMETRIC

IMPORTANT:

Please read this information and follow all safety rules carefully before operating your security vault. Failure to do so will void your warranty.

TABLE OF CONTENTS

<i>IMPORTANT INFORMATION</i>	2
<i>1. REGISTRATION</i>	3
<i>2. UNDERSTANDING YOUR VAULT</i>	4
<i>3. INITIAL ENTRY</i>	5
<i>4. BATTERY INSTALLATION</i>	6
<i>5. PLACEMENT AND MOUNTING YOUR VAULT</i>	6
<i>6. PROGRAMMING YOUR FINGERPRINT</i>	9
<i>7. OPENING VAULT WITH PROGRAMMED FINGERPRINT</i>	10
<i>8. PROGRAMMING ADDITIONAL FINGERPRINTS</i>	10
<i>9. TROUBLE SHOOTING</i>	11
<i>10. LOCKOUT MODE/TAMPER PROTECTION</i>	12
<i>11. CLEARING ALL RECORDED FINGERPRINTS</i>	13
<i>12. SILENT ENTRY MODE</i>	13
<i>13. LOADING YOUR VAULT</i>	13
<i>14. MAINTAINING HINGES AND INTERNAL MECHANISMS</i>	13
<i>WARRANTY</i>	14

DISCLAIMER - READ BEFORE VAULT SETUP

PLEASE READ THIS INFORMATION CAREFULLY BEFORE OPERATING YOUR SPORTS AFIELD VAULT.

DO NOT LOCK THIS MANUAL OR THE OVERRIDE ACCESS KEYS IN YOUR VAULT.

- Thank you for choosing a Sports Afield vault to protect your valuables. We are committed to securing, organizing and protecting your most important documents, valuables and keepsakes.
- If you experience problems or challenges with your vault, please contact us. Many issues can be quickly resolved without the product being returned.

Contact Customer Service at cs@saproducts.com or (888) 792-4264

SAFETY

- Be sure to keep backup keys stored in a safe place away from unauthorized users
- Do not put anything in your vault that will put pressure against the door when it is closed.

WEAPON STORAGE

- If you choose to utilize this vault to store a weapon always follow proper weapon and local laws when storing a weapon.
- SA Consumer Products strongly recommends that you do not store loaded guns.
- Always follow the firearm safety rules set out by the firearm's manufacturer.
- Store ammunition separately from valuables.
- A Sports Afield vault or any other firearm storage device cannot take the place of other safety procedures including advising children of the dangers of firearms.
- SA Consumer Products and its distributors of the Sports Afield vaults do not recommend, suggest, advise, promote, or otherwise condone the ownership or use of firearms. We believe the decision to own or use a firearm is a serious decision that should only be made by an adult who has carefully considered the risks and benefits of such a decision.

1. REGISTRATION

Register your vault at www.saproducts.com

By registering your Sports Afield vault we will be able to expedite and address any problems or challenges you may have which would otherwise require a notary letter and proof of payment.

REGISTRATION INFORMATION

The information you record onto this page will be required in the event you cannot access the contents of your Sports Afield vault. Please fill out all the required information below and retain for your records and safe keeping.

PLEASE HAVE THIS INFORMATION READY PRIOR TO CALLING FOR TECHNICAL ASSISTANCE AT:

Contact Customer Service at cs@saproducts.com or (888) 792-4264

PURCHASE DATE:

PURCHASE PRICE (BEFORE TAX):

MODEL NUMBER:

SERIAL NUMBER:

RETAILER NAME:

KEY NUMBER (IF APPLICABLE):

2. UNDERSTANDING YOUR VAULT

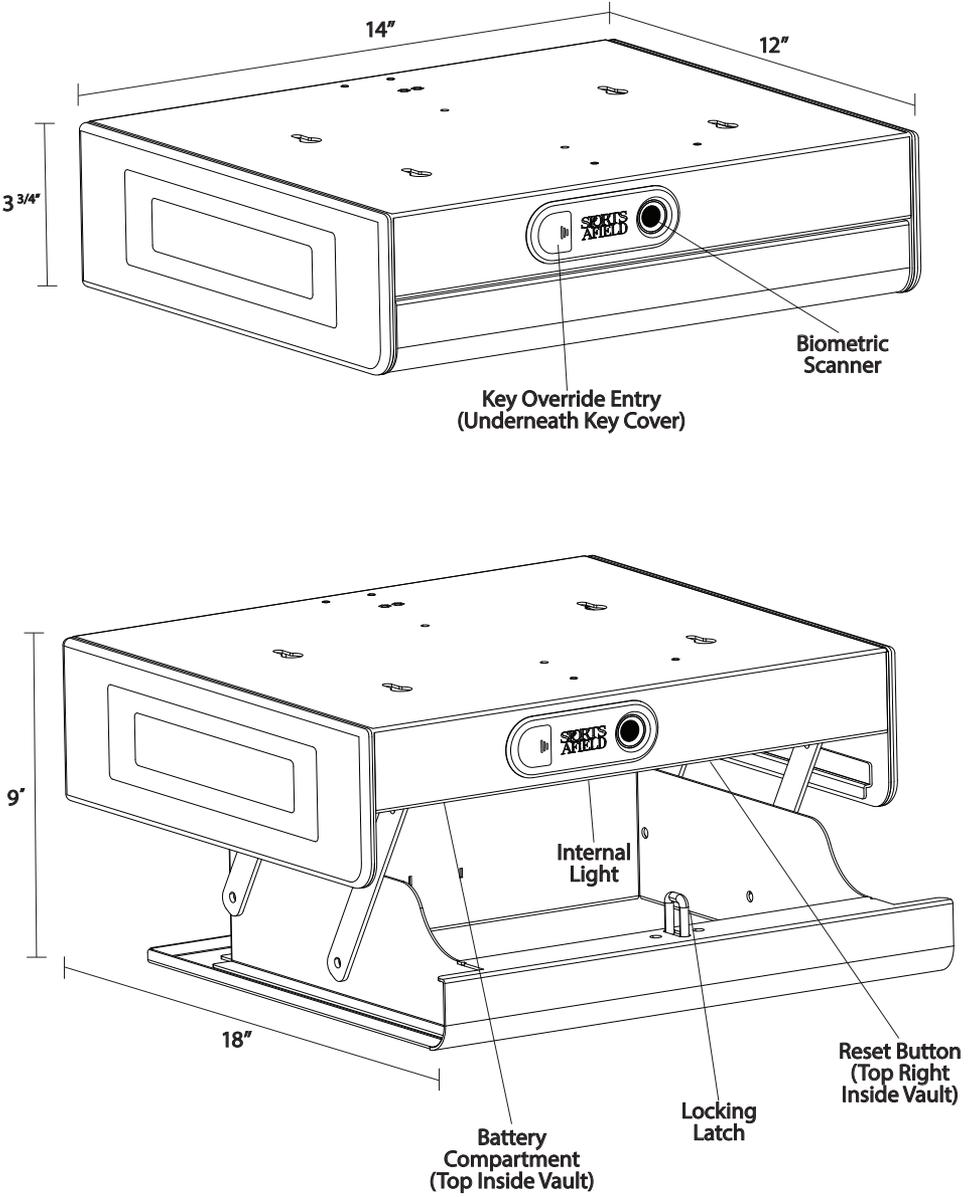

3. INITIAL ENTRY

1. When unboxing, you will see the manual, mounting plate and key on top of the vault. Remove these items and set aside.

Lay down a towel or protective barrier and place the vault on it's side. Locate the key cover and remove it by pressing the three lines. The cover will pop up on one side so that it can be removed.

Step 1

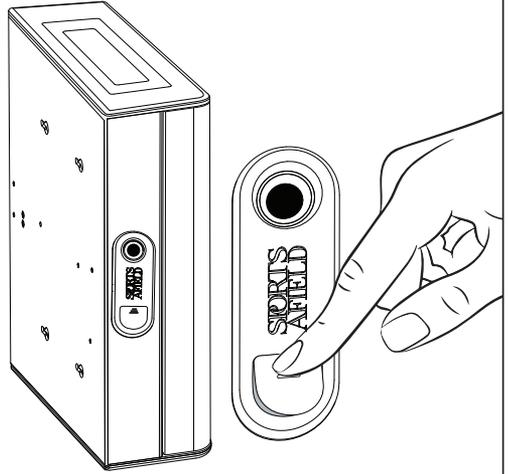

2. Insert the backup key. Turn the key clockwise and your vault door will unlock.

Step 2

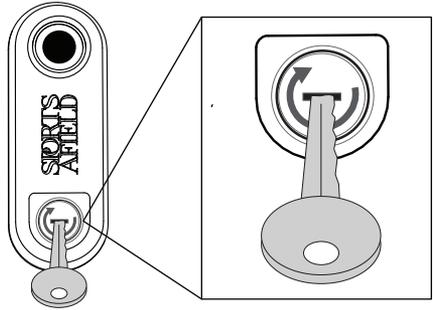

3. Gently pull it open while keeping it on it's side.

Remove the box of hardware from the vault and set aside.

Step 3

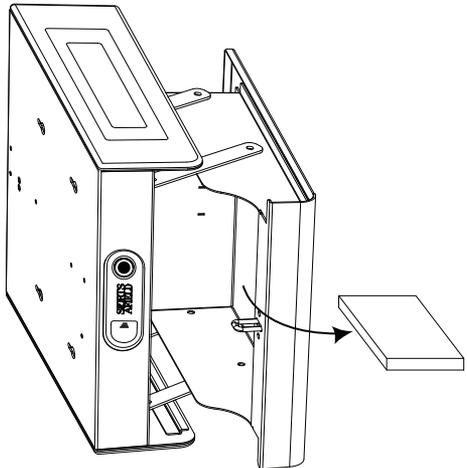

4. BATTERY INSTALLATION

1. While vault is still on it's side, find the battery compartment located inside on the top of the vault. Press the tab to release the battery tray.

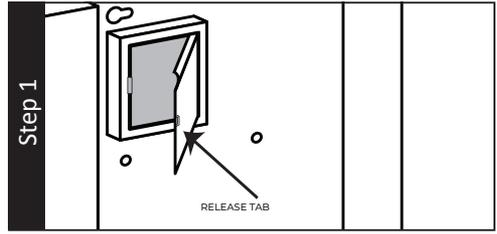

2. Remove the empty battery tray from the compartment.

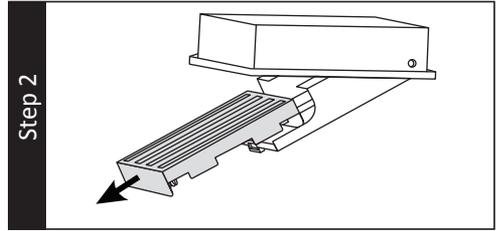

3. Turn over the tray and insert the (4) AAA batteries (included) into the tray in the correct orientation.

WARNING: The batteries must be inserted with the correct polarity. Exhausted batteries must be removed from the product and discarded safely. Do not mix old and new batteries. Do not mix alkaline or standard (carbon – zinc) batteries. Do not use rechargeable (nickel – cadmium) batteries.

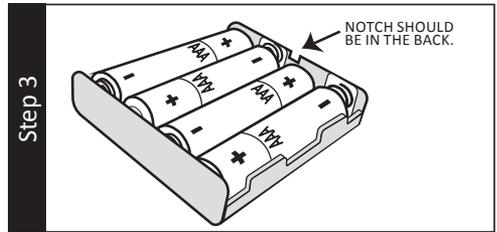

4. Turn the battery pack over to align the notch cut out on the battery tray to the ridge inside of the battery compartment.

Slide the tray back into the battery compartment. The keypad will beep once when batteries are successfully installed.

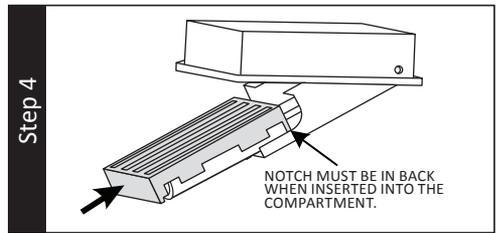

5. PLACEMENT AND MOUNTING YOUR VAULT

Mounting with Provided Hardware

⚠ IMPORTANT: Consult your local hardware retailer for proper hardware for your desired mounting surface.

TOOLS NEEDED:

- DRILL / HAMMER DRILL
- 3/32" DRILL BIT
- PHILLIPS SCREWDRIVER

HARDWARE INCLUDED:

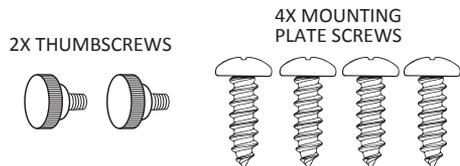

5. PLACEMENT AND MOUNTING YOUR VAULT (Continued)

Planning Your Space

This vault is intended to be mounted under a surface of your choice. Some possibilities include under your desk, under a bench, under a cabinet or any other location that is convenient for you. Before beginning the process, take a moment to review the size of your vault and evaluate that you will have enough space for the drawer to drop open.

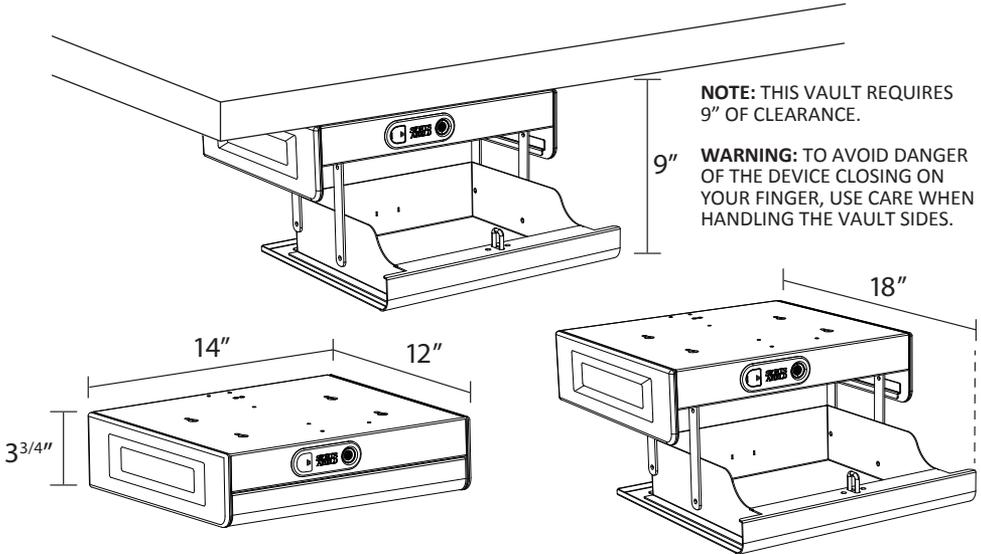

In order to mount the vault flush to the edge of your desk or desired surface, use the provided template and complete the following steps for mounting. Keep in mind, when the vault drawer is fully open it will extend 6" beyond the edge of your desk so that you may easily and quickly access the contents.

Using the Provided Template

The provided screws are designed for mounting to surfaces of 1/2 inch or thicker. If your surface is less than 1/2 inch thick, different mounting hardware is needed.

1. Align the template with the front edge of your or chosen surface. Use a pencil to mark the location of the (4) holes.
2. Drill pilot holes on marked locations.
3. Line up the mounting plate with pilot holes and hold in position.
4. While continuing to hold, using a screwdriver or power drill, fasten the plate to the surface using provided screws.

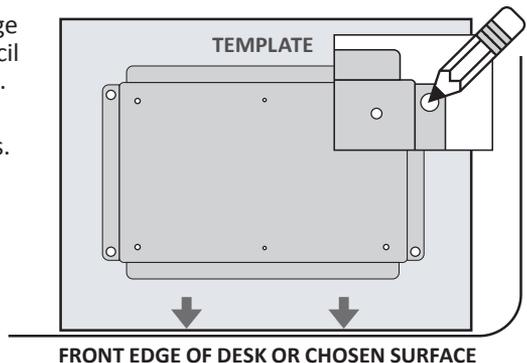

5. PLACEMENT AND MOUNTING YOUR VAULT (Continued)

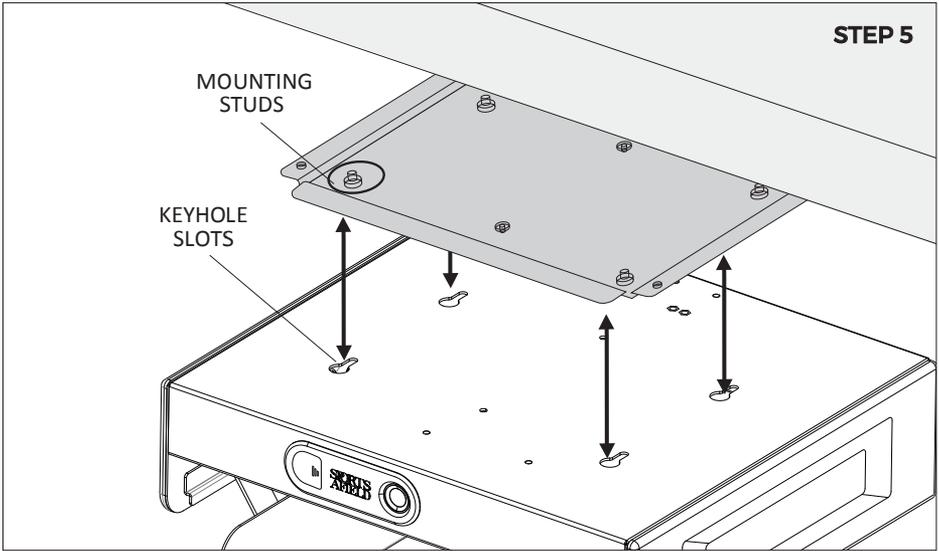

- Locate the (4) mounting studs and the (4) keyhole slots on top of unit.
- With the unit opened, align all 4 mounting plate studs with the key hole slots, push head of mounting studs through key hole slots and **slide the unit forward** to engage.



UNIT IS NOT YET FULLY SECURE. DO NOT OPERATE UNIT COMPLETING STEP 6.

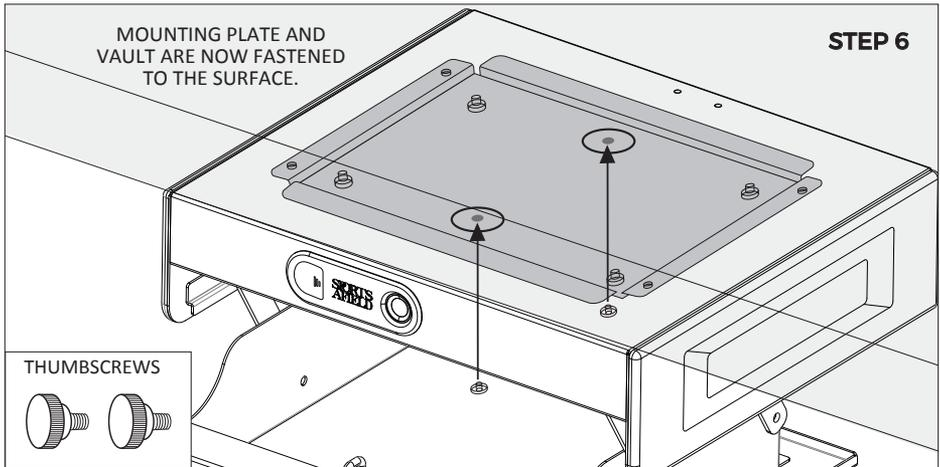

- Locate the (2) thumb screw holes on the top, inside of the vault. Hold the unit in position and use (2) thumb screws to fasten the unit to the mounting plate.

6. PROGRAMMING YOUR FINGERPRINT

1. Behind the front panel, inside the right hand side of the vault, you will find a reset button.

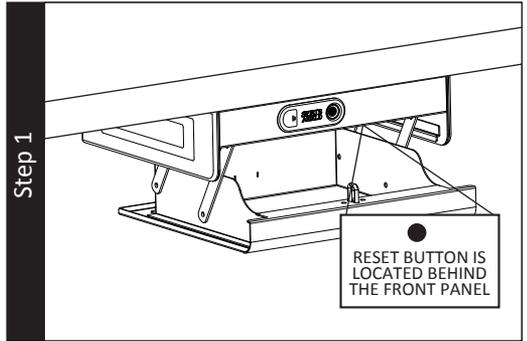

2. Press the reset button to start the programming process. You will hear one beep and the indicator ring will illuminate on the front of the door.

NOTE: Recording mode will time out after 10 seconds of inactivity. If this occurs press reset button and begin again.

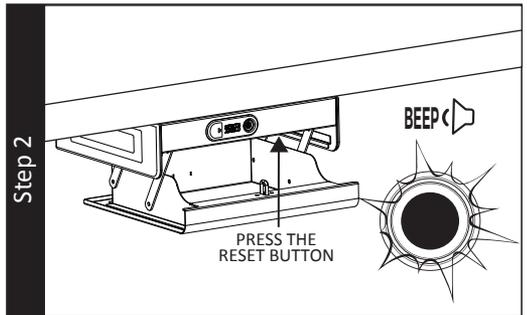

3. **Place and hold** the pad of your finger on the scanner **until it flashes green and beeps one time.**

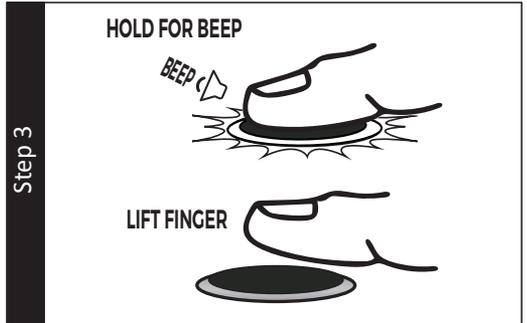

4. **Repeat at least 3 more times** until there are **2 consecutive beeps** and **2 green flashes.**

⚠ IMPORTANT: Be sure to use the same finger for each recording sequence.

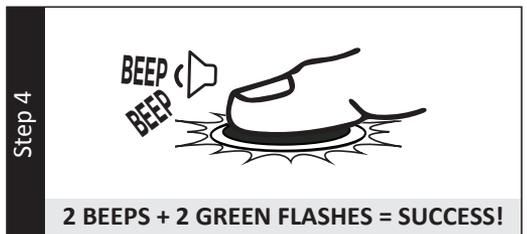

7. OPENING VAULT WITH PROGRAMMED FINGERPRINT

With keys in hand, close and lock the door.

Place and hold the **programmed** finger on the scanner and indicator ring will illuminate green and the vault will unlock. **You can now open your vault.**



If your print is not accepted: you will see 1 light flash with 1 sound. This means the scanner did not read your fingerprint (try again).

⚠ IMPORTANT: If you see 5 red flashes with 5 sounds, the scanner read your fingerprint but did not accept it. Follow section 6 to reprogram your fingerprint.

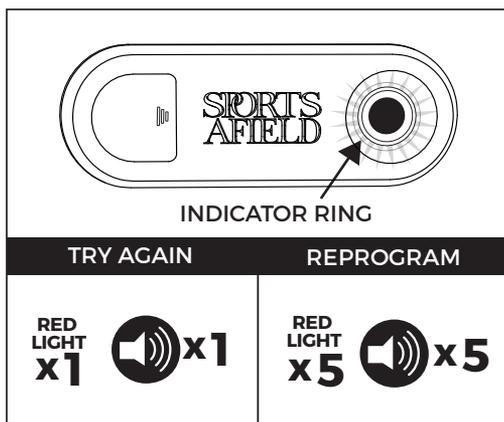

8. PROGRAMMING ADDITIONAL FINGERPRINTS

When accessing your vault quickly, there is a chance you may touch the scanner with a part of your finger that you have not registered before. For this reason, we recommend programming additional areas of your fingerprint to ensure fast and reliable entry to your vault.

INDIVIDUALLY MAPPING ALL ZONES OF YOUR FINGERPRINT WILL ENSURE A RELIABLE READING BY THE SCANNER.

To ensure each programming sequence is properly captured, it needs to read the exact same place on your finger four times in a row, once successful you can move onto the next zone of your fingerprint. This counts as one programmed fingerprint of 100 fingerprints this unit can keep in memory.

Once programming sequence has been successfully completed, you can move onto the next zone of your fingerprint.

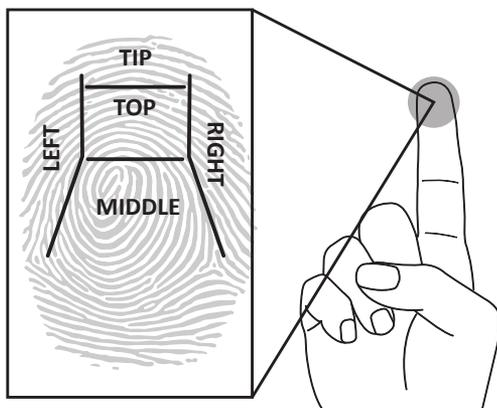

8. RECORDING ADDITIONAL FINGERPRINTS (Continued)

Press the reset button and follow Step 6 instructions again, for each fingerprint zone you would like to program.

If you experience any problems reading your fingerprint, including inconsistent readings, note the area of your fingerprint that doesn't work properly, and specifically re-program that area.

This scanner will hold up to 100 different fingerprints.

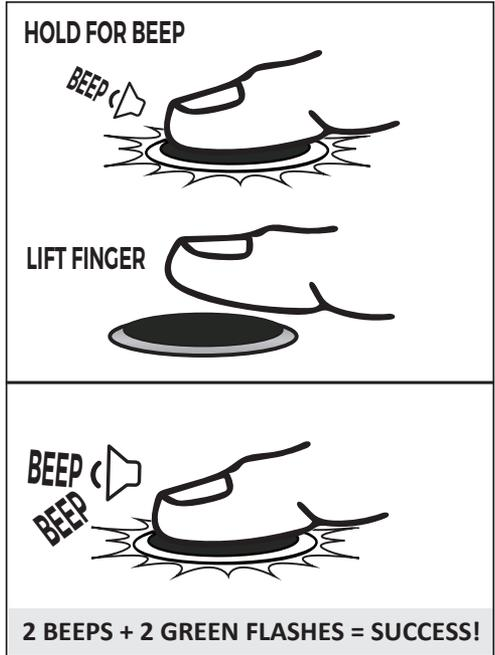

9. TROUBLE SHOOTING

In the event that you run into issues with programming and accessing your vault, please read through this section for answers to your questions.

PROBLEM	SOLUTION
YOUR PROGRAMMED FINGERPRINT IS NOT READING AT ALL TIMES	Make sure batteries are fresh. We suggest high grade alkaline. Do not mix old and new batteries. No not use rechargeable batteries.
	Make sure you are placing the same part of your fingerprint on the scanner that was used for programming. If not, make note of the area that is not scanning and program that area specifically.
	Placing a portion of a fingerprint on the scanner that has not been programmed can result in an error. We recommend programming multiple areas of each fingerprint.

9. TROUBLE SHOOTING (Continued)

PROBLEM	SOLUTION
YOUR FINGERPRINT IS NOT READING	Make sure to hold down your finger on the scanner instead of tapping, as the scanner needs time to complete the scanning process.
	Fingerprints may lack definition due to excessive dryness. We recommend applying moisturizer or slide your finger print against your forehead before scanning process.
WILL PRESSING THE RESET BUTTON CLEAR THE MEMORY	Pressing and releasing the reset button will not erase fingerprints already recorded. It simply places the scanner in programming mode to allow for additional fingerprints to be programmed. This unit will hold up to 100 unique fingerprints.

Low Battery Indicator



If you notice your indicator light is not remaining on for a few seconds upon entering, replace batteries immediately to avoid being locked out of your vault.

Locked Out Of Your Vault

In the event you are locked out your vault, use your backup keys to gain access and follow the section 6 Initial Entry instructions.

If you have lost your backup keys, or are still having any difficulties, contact customer service at the number below. Proof of purchase is required to obtain keys.

Contact Customer Service at (888) 792-4264 or cs@saproducts.com

10. LOCKOUT MODE/TAMPER PROTECTION

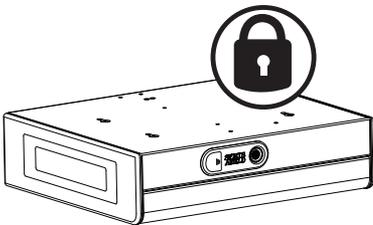

1. Three consecutive incorrect code entries will put the vault in "Basic Lockout" mode. Scanner is deactivated for 30 seconds.
2. After "Basic Lockout" mode has ended, another three consecutive incorrect code entries will result in "Severe Lockout" mode. Scanner is deactivated for 5-minutes.

11. CLEARING ALL RECORDED FINGERPRINTS

Hold Reset button. Initially, you will hear one beep. Continue holding reset button for 5 seconds, the indicator ring will flash green two times and beep two times.

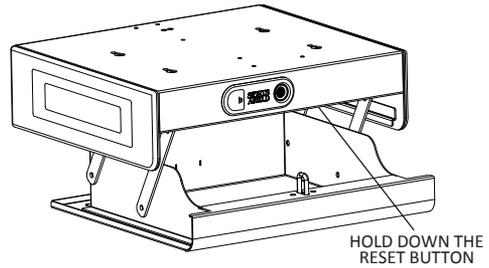

NOTE:

If 100 max fingerprints have already been programmed indicator ring will flash 5 times and beep 5 times. We recommend clearing all programmed fingerprints and starting the programming process over.

12. SILENT ENTRY MODE

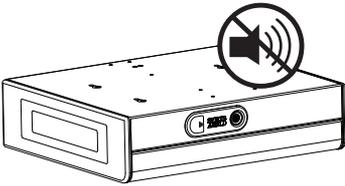

To initiate silent entry mode, hold a programmed finger on the scanner for 5 seconds beyond your fingerprint being accepted. The green indicator ring will turn off and back on, but will not beep, indicating you are now in silent entry mode.

You will not hear any sounds for any functions while the vault is in silent entry mode.

To turn the sound back on, hold a programmed finger on the scanner for 5 seconds beyond your fingerprint being accepted. The green indicator ring will turn off and back on and will beep once indicating you are no longer in silent entry mode.

13. LOADING YOUR VAULT

1. Store ammunition separately from valuables.
2. Don't put anything in your vault that will put pressure against the door when closed.
3. Be aware that the drawer can get jammed when large or bulky items are stored exceeding the maximum height of 2 ¹/₂ to 3 inches.

14. MAINTAINING HINGES AND INTERNAL MECHANISMS

The hinges and internal locking mechanism are permanently lubricated, thus needing no maintenance. Opening the door panel of your vault may void your warranty. Always consult our customer service experts prior to doing so.

THREE YEAR WARRANTY

SA Consumer Products will repair or replace, at their sole discretion, any Sports Afield vault damaged by fire, forced entry, forced attack or natural flood for the lifetime of the original owner.

SA Consumer Products will repair or replace, at their sole discretion, any Sports Afield vault with defective parts, paint or lock for three years of the original owner purchase date.

If SA Consumer Products deems a replacement vault is to be sent, they will pay the freight costs to ship the replacement vault to the original owner.

This three year warranty is limited to the vault and expressly excludes any loss associated with the contents of the vault.

SA Consumer Products reserves the right to receive full evidence of your misfortune, such as a police report and/or homeowner's statement of coverage. This warranty is not valid outside of the United States and Canada.

Proof of registration and copy of sales receipt must be on file at the time of claim. Visit our website at www.saproducts.com to register your vault.

Three year warranty only applies to the original owner of the vault.

SA Consumer Products shall only be responsible and liable when the vault is used in compliance with the directions specified in your new SA Consumer Products owner's manual.

SA Consumer Products requires that specific guidelines be followed for repair. The vault will be repaired in-home if possible (to include parts and labor); however, if factory replacement is necessary (at SA Consumer Products' sole discretion), the replacement will be shipped freight prepaid, curbside delivery.

This warranty is inclusive and is in lieu of any and all other warranties, express or implied. Specifically excluded are the warranties of merchantability and fitness for a particular purpose. This warranty is limited to the vault itself and/or its value and does not include consequential damages of any kind including, but not limited to, the contents in and of the vault.